

## ***A Few Words About Safety***

### **Service Information**

The service and repair information contained in this manual is intended for use by qualified, professional technicians. Attempting service or repairs without the proper training, tools, and equipment could cause injury to you or others. It could also damage the vehicle or create an unsafe condition.

This manual describes the proper methods and procedures for performing service, maintenance, and repairs. Some procedures require the use of specially designed tools and dedicated equipment. Any person who intends to use a replacement part, service procedure or a tool that is not recommended by Honda, must determine the risks to their personal safety and the safe operation of the vehicle.

If you need to replace a part, use genuine Honda parts with the correct part number or an equivalent part. We strongly recommend that you do not use replacement parts of inferior quality.

### **For Your Customer's Safety**

Proper service and maintenance are essential to the customer's safety and the reliability of the vehicle. Any error or oversight while servicing a vehicle can result in faulty operation, damage to the vehicle, or injury to others.

### **For Your Safety**

Because this manual is intended for the professional service technician, we do not provide warnings about many basic shop safety practices (e.g., Hot parts – wear gloves). If you have not received shop safety training or do not feel confident about your knowledge of safe servicing practices, we recommended that you do not attempt to perform the procedures described in this manual.

Some of the most important general service safety precautions are given below. However, we cannot warn you of every conceivable hazard that can arise in performing service and repair procedures. Only you can decide whether or not you should perform a given task.

### **Important Safety Precautions**

Make sure you have a clear understanding of all basic shop safety practices and that you are wearing appropriate clothing and using safety equipment. When performing any service task, be especially careful of the following:

- Read all of the instructions before you begin, and make sure you have the tools, the replacement or repair parts, and the skills required to perform the tasks safely and completely.
- Protect your eyes by using proper safety glasses, goggles or face shields any time you hammer, drill, grind, pry or work around pressurized air or liquids, and springs or other stored-energy components. If there is any doubt, put on eye protection.
- Use other protective wear when necessary, for example gloves or safety shoes. Handling hot or sharp parts can cause severe burns or cuts. Before you grab something that looks like it can hurt you, stop and put on gloves.
- Protect yourself and others whenever you have the vehicle up in the air. Any time you lift the vehicle, either with a hoist or a jack, make sure that it is always securely supported. Use jack stands.

Make sure the engine is off before you begin any servicing procedures, unless the instruction tells you to do otherwise. This will help eliminate several potential hazards:

- Carbon monoxide poisoning from engine exhaust. Be sure there is adequate ventilation whenever you run the engine.
- Burns from hot parts or coolant. Let the engine and exhaust system cool before working in those areas.
- Injury from moving parts. If the instruction tells you to run the engine, be sure your hands, fingers and clothing are out of the way.

Gasoline vapors and hydrogen gases from batteries are explosive. To reduce the possibility of a fire or explosion, be careful when working around gasoline or batteries.

- Use only a nonflammable solvent, not gasoline, to clean parts.
- Never drain or store gasoline in an open container.
- Keep all cigarettes, sparks and flames away from the battery and all fuel-related parts.

#### **⚠ WARNING**

Improper service or repairs can create an unsafe condition that can cause your customer or others to be seriously hurt or killed.

Follow the procedures and precautions in this manual and other service materials carefully.

#### **⚠ WARNING**

Failure to properly follow instructions and precautions can cause you to be seriously hurt or killed.

Follow the procedures and precautions in this manual carefully.

# HOW TO USE THIS MANUAL

This service manual describes the service procedures for the GL1800/GL1800A.

Follow the Maintenance Schedule (Section 3) recommendations to ensure that the vehicle is in peak operating condition and emission levels are within the standards set by the California Air Resources Board (CARB).

Performing the first scheduled maintenance is very important. It compensates for the initial wear that occurs during the break-in period.

Sections 1 and 3 apply to the whole motorcycle. Section 2 illustrates procedures for removal/installation of components that may be required to perform service described in the following sections.

Sections 4 through 22 describe parts of the motorcycle, grouped according to location.

Find the section you want on this page, then turn to the table of contents on the first page of the section.

Most sections start with an assembly or system illustration, service information and troubleshooting for the section. The subsequent pages give detailed procedures.

If you don't know the source of the trouble, go to Section 24, Troubleshooting.

Your safety, and the safety of others, is very important. To help you make informed decisions we have provided safety messages and other information throughout this manual. Of course, it is not practical or possible to warn you about all the hazards associated with servicing this vehicle. You must use your own good judgement. You will find important safety information in a variety of forms including:

- Safety Labels – on the vehicle
- Safety Messages – preceded by a safety alert symbol  and one of three signal words, DANGER, WARNING, or CAUTION. These signal words mean:

**DANGER** You WILL be KILLED or SERIOUSLY HURT if you don't follow instructions.

**WARNING** You CAN be KILLED or SERIOUSLY HURT if you don't follow instructions.

**CAUTION** You CAN be HURT if you don't follow instructions.

- Instructions – how to service this vehicle correctly and safely.

As you read this manual, you will find information that is preceded by a **NOTICE** symbol. The purpose of this message is to help prevent damage to your vehicle, other property, or the environment.

**ALL INFORMATION, ILLUSTRATIONS, DIRECTIONS AND SPECIFICATIONS INCLUDED IN THIS PUBLICATION ARE BASED ON THE LATEST PRODUCT INFORMATION AVAILABLE AT THE TIME OF APPROVAL FOR PRINTING. HONDA MOTOR CO., LTD. RESERVES THE RIGHT TO MAKE CHANGES AT ANY TIME WITHOUT NOTICE AND WITHOUT INCURRING ANY OBLIGATION WHATSOEVER. NO PART OF THIS PUBLICATION MAY BE REPRODUCED WITHOUT WRITTEN PERMISSION. THIS MANUAL IS WRITTEN FOR PERSONS WHO HAVE ACQUIRED BASIC KNOWLEDGE OF MAINTENANCE ON HONDA MOTORCYCLES, MOTOR SCOOTERS, OR ATVS.**

HONDA MOTOR CO., LTD.  
SERVICE PUBLICATIONS OFFICE











# CONTENTS

	<b>GENERAL INFORMATION</b>	<b>1</b>
	<b>FRAME/BODY PANELS/EXHAUST SYSTEM</b>	<b>2</b>
	<b>MAINTENANCE</b>	<b>3</b>
<b>ENGINE AND DRIVE TRAIN</b>	<b>LUBRICATION SYSTEM</b>	<b>4</b>
	<b>FUEL SYSTEM (Programmed Fuel Injection)</b>	<b>5</b>
	<b>COOLING SYSTEM</b>	<b>6</b>
	<b>ENGINE REMOVAL/INSTALLATION</b>	<b>7</b>
	<b>CYLINDER HEAD/VALVES</b>	<b>8</b>
	<b>CLUTCH</b>	<b>9</b>
	<b>GEARSHIFT LINKAGE/TRANSMISSION</b>	<b>10</b>
	<b>CYLINDER/PISTON/CRANKSHAFT</b>	<b>11</b>
	<b>FINAL DRIVE</b>	<b>12</b>
	<b>CHASSIS</b>	<b>FRONT WHEEL/SUSPENSION/STEERING</b>
<b>REAR WHEEL/SUSPENSION</b>		<b>14</b>
<b>BRAKE SYSTEM (Standard)</b>		<b>15</b>
<b>BRAKE SYSTEM (ABS)</b>		<b>16</b>
<b>ELECTRICAL</b>	<b>BATTERY/CHARGING SYSTEM</b>	<b>17</b>
	<b>IGNITION SYSTEM</b>	<b>18</b>
	<b>STARTER/REVERSE SYSTEM</b>	<b>19</b>
	<b>LIGHTS/METERS/SWITCHES</b>	<b>20</b>
	<b>CRUISE CONTROL SYSTEM</b>	<b>21</b>
	<b>AUDIO SYSTEM</b>	<b>22</b>
	<b>WIRING DIAGRAMS</b>	<b>23</b>
<b>TECHNICAL FEATURES</b>	<b>24</b>	
<b>TROUBLESHOOTING</b>	<b>25</b>	
<b>INDEX</b>	<b>26</b>	



# SYMBOLS

The symbols used throughout this manual show specific service procedures. If supplementary information is required pertaining to these symbols, it would be explained specifically in the text without the use of the symbols.

	<p>Replace the part(s) with new one(s) before assembly.</p>
	<p>Use recommended engine oil, unless otherwise specified.</p>
	<p>Use molybdenum oil solution (mixture of the engine oil and molybdenum grease in a ratio of 1:1).</p>
	<p>Use multi-purpose grease (lithium based multi-purpose grease NLGI #2 or equivalent).</p>
	<p>Use molybdenum disulfide grease (containing more than 3% molybdenum disulfide, NLGI #2 or equivalent).            Example: Molykote® BR-2 Plus manufactured by Dow Corning, U.S.A.            Multi-purpose M-2 manufactured by Mitsubishi Oil, Japan</p>
	<p>Use molybdenum disulfide paste (containing more than 40% molybdenum disulfide, NLGI #2 or equivalent).            Example: Molykote® G-n Paste manufactured by Dow Corning, U.S.A.            Honda Moly 60 (U.S.A. only)            Rocol ASP manufactured by Rocol Limited, U.K.            Rocol Paste manufactured by Sumico Lubricant, Japan</p>
	<p>Use silicone grease.</p>
	<p>Apply a locking agent. Use a medium strength locking agent unless otherwise specified.</p>
	<p>Use sealant.</p>
	<p>Use DOT 3 or DOT 4 brake fluid. Use the recommended brake fluid unless otherwise specified.</p>
	<p>Use fork or suspension fluid.</p>

# 1. GENERAL INFORMATION

---

SERVICE RULES .....	1-2	BRAKE SYSTEM SPECIFICATIONS.....	1-10
MODEL IDENTIFICATION.....	1-2	BATTERY/CHARGING SYSTEM SPECIFICATIONS.....	1-10
GENERAL SPECIFICATIONS.....	1-4	IGNITION SYSTEM SPECIFICATIONS .....	1-11
LUBRICATION SYSTEM SPECIFICATIONS ·	1-6	STARTER/REVERSE SYSTEM SPECIFICATIONS.....	1-11
FUEL SYSTEM (Programmed Fuel Injection) SPECIFICATIONS.....	1-6	LIGHTS/METERS/SWITCHES SPECIFICATIONS.....	1-11
COOLING SYSTEM SPECIFICATIONS .....	1-6	CRUISE CONTROL SYSTEM SPECIFICATIONS.....	1-11
CYLINDER HEAD/VALVE SPECIFICATIONS.....	1-7	STANDARD TORQUE VALUES .....	1-12
CLUTCH SPECIFICATIONS .....	1-7	ENGINE & FRAME TORQUE VALUES .....	1-12
GEARSHIFT LINKAGE/TRANSMISSION SPECIFICATIONS.....	1-8	LUBRICATION & SEAL POINTS .....	1-19
CYLINDER/PISTON/CRANKSHAFT SPECIFICATIONS.....	1-8	CABLE & HARNESS ROUTING .....	1-23
FINAL DRIVE SPECIFICATIONS.....	1-9	EMISSION CONTROL SYSTEMS .....	1-69
FRONT WHEEL/SUSPENSION/STEERING SPECIFICATIONS.....	1-9	EMISSION CONTROL INFORMATION LABELS .....	1-72
REAR WHEEL/SUSPENSION SPECIFICATIONS.....	1-9		

## GENERAL INFORMATION

---

### SERVICE RULES

1. Use genuine Honda or Honda-recommended parts and lubricants or their equivalents. Parts that don't meet HONDA's design specifications may cause damage to the motorcycle.
2. Use the special tools designed for this product to avoid damage and incorrect assembly.
3. Use only metric tools when servicing the motorcycle. Metric bolts, nuts, and screws are not interchangeable with English fasteners.
4. Install new gaskets, O-rings, cotter pins, and lock plates when reassembling.
5. When tightening bolts or nuts, begin with the larger diameter or inner bolt first. Then tighten to the specified torque diagonally in incremental steps unless a particular sequence is specified.
6. Clean parts in cleaning solvent upon disassembly. Lubricate any sliding surfaces before reassembly.
7. After reassembly, check all parts for proper installation and operation.
8. Route all electrical wires as shown in the Cable & Harness Routing (page 1-23).

### MODEL IDENTIFICATION

This manual covers 2 types of GL1800 models:

- GL1800 – no ABS
- GL1800A – equipped with ABS

Be sure to refer to the procedure for the appropriate version of the GL1800.

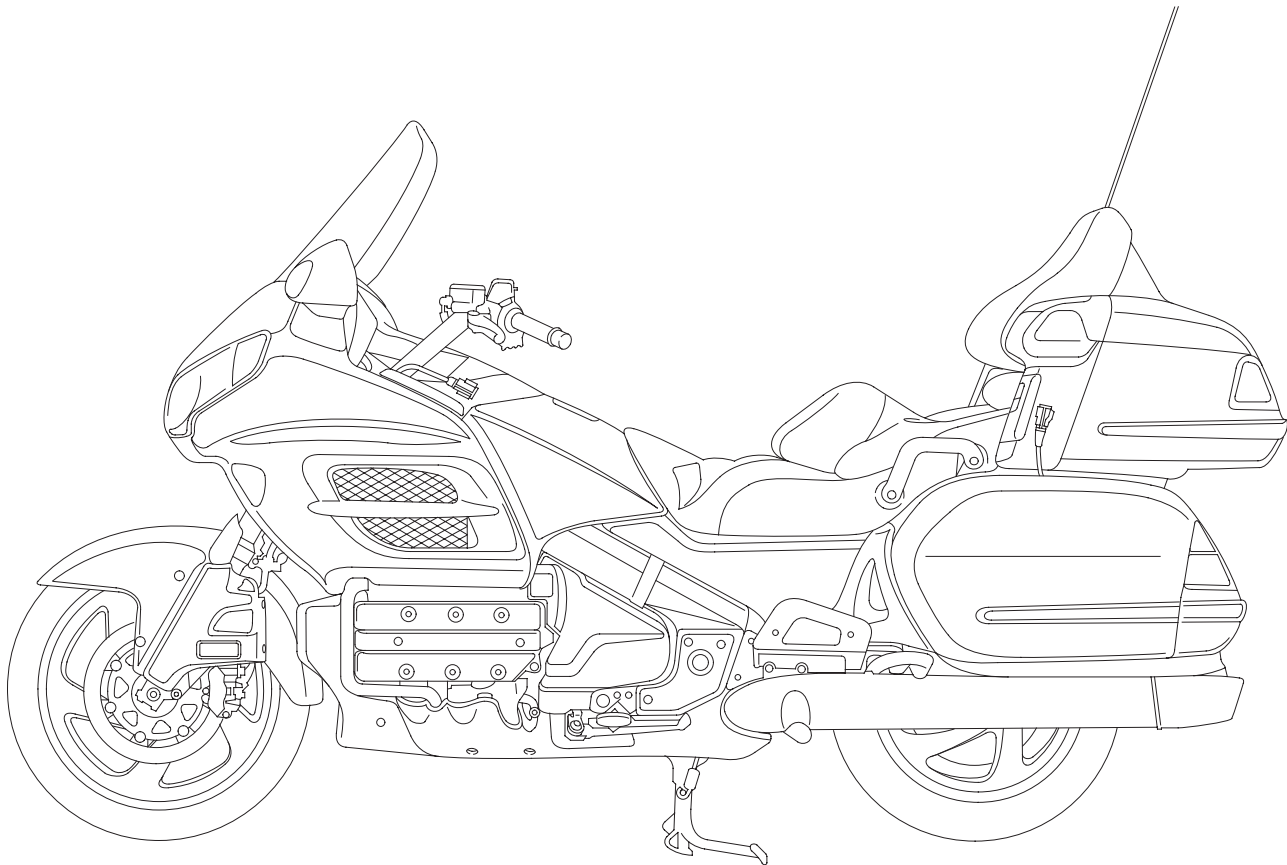

## GENERAL INFORMATION

The frame serial number is stamped on the right side of the steering head.

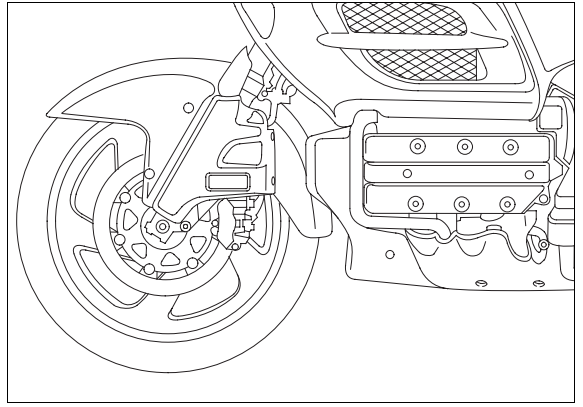

The engine serial number is stamped on the right side of the crankcase.

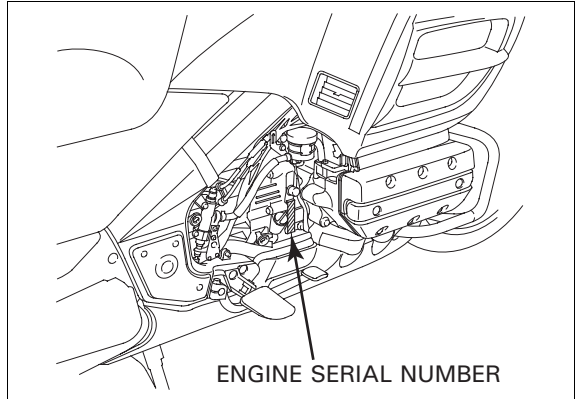

The Vehicle Identification Number (VIN) is located on the left side of the frame near the steering head.

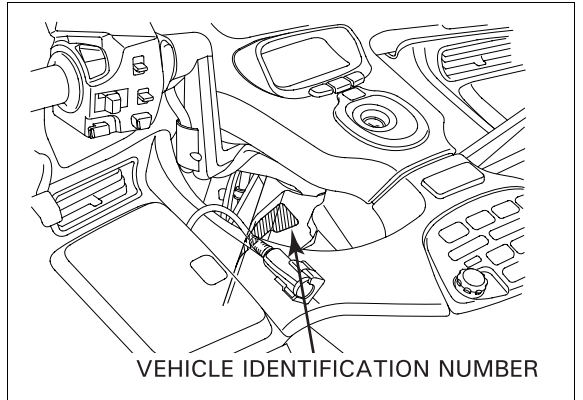

The throttle body identification number is stamped on the rear of the throttle body.

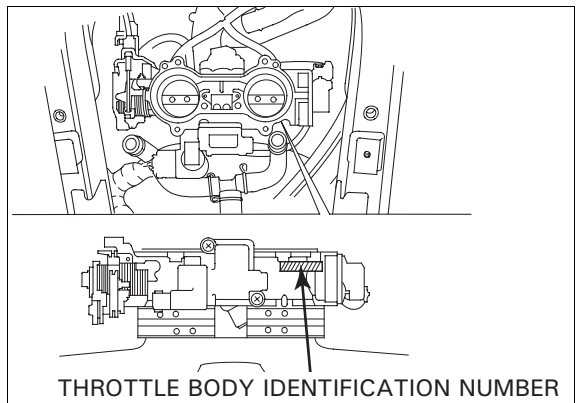

## GENERAL INFORMATION

The color label is attached on the back of the fuel fill compartment lid. When ordering color-coded parts, always specify the designated color code.

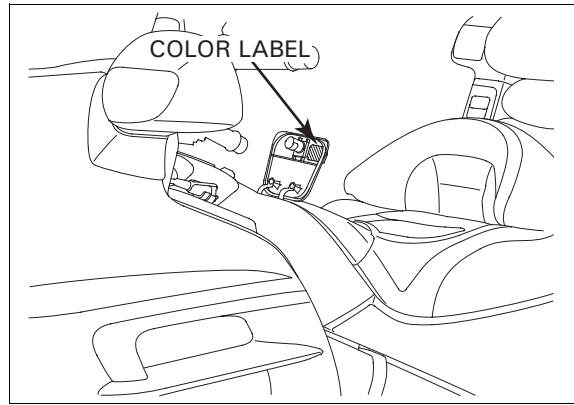

## GENERAL SPECIFICATIONS

	ITEM	SPECIFICATIONS
DIMENSIONS	Overall length	2,635 mm (103.7 in)
	Overall width	945 mm (37.2 in)
	Overall height	1,455 mm (57.3 in)
	Wheelbase	1,690 mm (66.5 in)
	Seat height	740 mm (29.1 in)
	Footpeg height	251 mm (9.9 in)
	Ground clearance	125 mm (4.9 in)
	Dry weight	No ABS: 359 kg (791 lbs) ABS model: 362 kg (798 lbs)
	Curb weight	No ABS: 399 kg (880 lbs) ABS model: 402 kg (886 lbs)
	Maximum weight capacity	U.S.A type: 189 kg (417 lbs) Canada type: 193 kg (425 lbs)
FRAME	Frame type	Diamond
	Front suspension	Telescopic fork
	Front axle travel	122 mm (4.8 in)
	Rear suspension	Swingarm
	Rear axle travel	105 mm (4.1 in)
	Front tire size	130/70R18M/C 63H
	Rear tire size	180/60R16M/C 74H
	Front tire brand	D250F (Dunlop), G709 RADIAL (Bridgestone)
	Rear tire brand	D250 (Dunlop), G704 RADIAL (Bridgestone)
	Brake system	Linked Brake System (LBS: All models) with Anti-lock Brake System (ABS: GL1800A)
	Front brake	Hydraulic double disc
	Rear brake	Hydraulic single disc
	Caster angle	29° 15'
Trail length	109 mm (4.3 in)	
Fuel tank capacity	25 liters (6.6 US gal, 5.5 Imp gal)	

## GENERAL INFORMATION

ITEM		SPECIFICATIONS						
ENGINE	Cylinder arrangement Bore and stroke Displacement Compression ratio Valve train Intake valve      opens closes Exhaust valve    opens closes Lubrication system Oil pump type Cooling system Air filtration Engine dry weight Firing order Cylinder number	Flat six 74.0 x 71.0 mm (2.91 x 2.80 in) 1,832 cm <sup>3</sup> (111.8 cu-in) 9.8 : 1 Silent cam chain driven, OHC -5° BTDC (5° ATDC) (at 1 mm lift) 30° ABDC (at 1 mm lift) 30° BBDC (at 1 mm lift) -5° ATDC (5° BTDC) (at 1 mm lift) Forced pressure and wet sump Trochoid Liquid cooled Viscous paper element 118.3 kg (260.8 lbs) 1 - 4 - 5 - 2 - 3 - 6 <table border="1" style="margin-left: auto; margin-right: auto;"> <tr> <td style="padding: 2px;">1</td> <td style="padding: 2px;">3</td> <td style="padding: 2px;">5</td> </tr> <tr> <td style="padding: 2px;">2</td> <td style="padding: 2px;">4</td> <td style="padding: 2px;">6</td> </tr> </table> ← Front	1	3	5	2	4	6
1	3	5						
2	4	6						
FUEL DELIVERY SYSTEM	Type Throttle bore	Programmed Fuel Injection (PGM-FI) 40 mm (1.6 in)						
DRIVE TRAIN	Clutch system Clutch operation system Transmission Primary reduction Secondary reduction (output drive) Final reduction Gear ratio      1st 2nd 3rd 4th 5th Gearshift pattern	Multi-plate, wet (hydraulically assisted) Hydraulically operated Constant mesh, 5-speeds with reverse 1.591 (78/49) 1.028 (36/35) 2.750 (33/12) 2.375 (38/16) 1.454 (32/22) 1.068 (31/29) 0.843 (27/32) 0.686 (24/35) Left foot operated return system, 1 - N - 2 - 3 - 4 - 5						
ELECTRICAL	Ignition system Starting system Charging system Regulator/rectifier Lighting system	Full transistorized ignition Electric starter motor Triple phase output alternator Triple phase full-wave rectification with field coil Battery						

## GENERAL INFORMATION

# LUBRICATION SYSTEM SPECIFICATIONS

Unit: mm (in)

ITEM		STANDARD	SERVICE LIMIT	
Engine oil capacity	After draining	3.6 liters (3.8 US qt, 3.2 Imp qt)	-	
	After draining/filter change	3.7 liters (3.9 US qt, 3.3 Imp qt)	-	
	After disassembly	4.6 liters (4.9 US qt, 4.0 Imp qt)	-	
Recommended engine oil		Pro Honda GN4 or HP4 (without molybdenum additives) 4-stroke oil or equivalent motor oil API service classification SG or Higher JASO T 903 standard: MA Viscosity: SAE 10W-40	-	
Oil pressure (at oil pressure switch)		530 kPa (5.4 kgf/cm <sup>2</sup> , 77 psi) at 5,000 rpm/80°C (176°F)	-	
Oil pump	Tip clearance	0.15 (0.006)	0.20 (0.008)	
	Body clearance	Feed side	0.15 - 0.21 (0.006 - 0.008)	0.35 (0.014)
		Scavenge side	0.15 - 0.22 (0.006 - 0.009)	0.35 (0.014)
	Side clearance	0.02 - 0.09 (0.001 - 0.004)	0.12 (0.005)	

# FUEL SYSTEM (Programmed Fuel Injection) SPECIFICATIONS

ITEM	SPECIFICATIONS
Throttle body identification number	GQ61A
Throttle grip free play	2 - 6 mm (1/12 - 1/4)
Intake air temperature sensor resistance (20°C/68°F)	2.2 - 2.7 kΩ
Engine coolant temperature sensor resistance (20°C/68°F)	2.3 - 2.6 kΩ
Throttle sensor resistance (20°C/68°F)	4 - 6 kΩ
Fuel injector resistance (20°C/68°F)	11.1 - 12.3 Ω
Camshaft position sensor peak voltage	0.7 V minimum
Ignition pulse generator peak voltage	0.7 V minimum
Manifold absolute pressure at idle	400 - 450 mm Hg (15.7 - 17.7 in Hg)
Fuel pressure at idle	343 kPa (3.5 kgf/cm <sup>2</sup> , 50 psi)
Fuel pump flow (at 12 V)	133 cm <sup>3</sup> (4.5 US oz, 4.7 Imp oz) minimum/10 seconds
Idle speed	700 ± 70 rpm

# COOLING SYSTEM SPECIFICATIONS

ITEM	SPECIFICATIONS	
Coolant capacity	Radiator and engine	3.53 liters (3.73 US qt, 3.11 Imp qt)
	Reserve tank	0.65 liter (0.69 US qt, 0.57 Imp qt)
Radiator cap relief pressure		108 - 137 kPa (1.1 - 1.4 kgf/cm <sup>2</sup> , 16 - 20 psi)
Thermostat	Begin to open	76 - 80°C (169 - 176°F)
	Fully open	90°C (194°F)
	Valve lift	8 mm (0.3 in) minimum
Recommended antifreeze		Pro Honda HP Coolant or an equivalent high quality ethylene glycol antifreeze containing silicate-free corrosion inhibitors
Standard coolant concentration		1:1 mixture with recommended antifreeze and soft water

## CYLINDER HEAD/VALVE SPECIFICATIONS

Unit: mm (in)

ITEM		STANDARD	SERVICE LIMIT
Cylinder compression at 300 rpm		1,383 kPa (14.1 kgf/cm <sup>2</sup> , 201 psi)	-
Valve clearance		IN	0.15 (0.006)
		EX	0.22 (0.009)
Camshaft	Cam lobe height	IN	41.610 – 41.690 (1.6382 – 1.6413)
		EX	41.680 – 41.760 (1.6409 – 1.6441)
	Runout		-
	Journal O.D.		27.959 – 27.980 (1.1007 – 1.1016)
	Journal I.D.		28.000 – 28.021 (1.1024 – 1.1032)
	Oil clearance		0.020 – 0.062 (0.0008 – 0.0024)
Valve lifter	Valve lifter O.D.	IN/EX	28.978 – 28.993 (1.1409 – 1.1415)
	Valve lifter bore I.D.	IN/EX	29.010 – 29.026 (1.1421 – 1.1428)
Valve, valve guide	Valve stem O.D.	IN	4.970 – 4.995 (0.1957 – 0.1967)
		EX	4.955 – 4.980 (0.1951 – 0.1961)
	Valve guide I.D.	IN/EX	5.000 – 5.012 (0.1969 – 0.1973)
	Stem-to-guide clearance	IN	0.005 – 0.042 (0.0002 – 0.0017)
		EX	0.020 – 0.057 (0.0008 – 0.0022)
	Valve guide projection above cylinder head	IN/EX	11.8 – 12.0 (0.46 – 0.47)
	Valve seat width	IN/EX	0.9 – 1.1 (0.035 – 0.043)
Valve spring	Free length	IN/EX	38.20 (1.504)
Cylinder head warpage		-	0.10 (0.004)

## CLUTCH SPECIFICATIONS

Unit: mm (in)

ITEM		STANDARD	SERVICE LIMIT
Specified clutch fluid		DOT 4 brake fluid	-
Clutch master cylinder	Cylinder I.D.	14.000 – 14.043 (0.5512 – 0.5529)	14.055 (0.5533)
	Piston O.D.	13.957 – 13.984 (0.5495 – 0.5506)	13.945 (0.5490)
Clutch	Clutch spring free height	4.8 (0.19)	4.6 (0.18)
	Clutch lifter spring free height	2.9 (0.11)	2.5 (0.10)
	Disc thickness	3.72 – 3.88 (0.146 – 0.153)	3.5 (0.14)
	Plate warpage	-	0.30 (0.012)



## GENERAL INFORMATION

# GEARSHIFT LINKAGE/TRANSMISSION SPECIFICATIONS

Unit: mm (in)

ITEM		STANDARD	SERVICE LIMIT	
Output shaft	Damper spring free length	66.0 (2.60)	64.0 (2.52)	
	Shaft O.D.	22.008 – 22.021 (0.8665 – 0.8670)	21.99 (0.866)	
	Gear bushing	I.D.	22.026 – 22.041 (0.8672 – 0.8678)	22.05 (0.868)
		O.D.	25.959 – 25.980 (1.0220 – 1.0228)	25.95 (1.022)
	Driven gear I.D.	26.000 – 26.013 (1.0236 – 1.0241)	26.03 (1.025)	
Shift fork	I.D.	14.000 – 14.018 (0.5512 – 0.5519)	14.04 (0.553)	
	Claw thickness	5.93 – 6.00 (0.233 – 0.236)	5.6 (0.22)	
Shift fork shaft	O.D.	13.966 – 13.984 (0.5498 – 0.5506)	13.90 (0.547)	
Transmission	Gear I.D.	M4	31.000 – 31.025 (1.2205 – 1.2215)	31.04 (1.222)
		M5	35.000 – 35.025 (1.3780 – 1.3789)	35.04 (1.380)
		C2, C3	33.000 – 33.025 (1.2992 – 1.3002)	33.04 (1.301)
	Gear bushing O.D.	M4	30.950 – 30.975 (1.2186 – 1.2195)	30.93 (1.218)
		M5	34.950 – 34.975 (1.3760 – 1.3770)	34.93 (1.375)
		C2, C3	32.950 – 32.975 (1.2972 – 1.2982)	32.93 (1.296)
	Gear-to-bushing clearance		0.025 – 0.075 (0.0010 – 0.0030)	0.10 (0.004)
	Gear bushing I.D.	M4	28.007 – 28.028 (1.1026 – 1.1035)	28.04 (1.104)
		M5	32.007 – 32.028 (1.2601 – 1.2609)	32.04 (1.261)
	Mainshaft O.D.	at M4	27.987 – 28.000 (1.1018 – 1.1024)	27.96 (1.101)
		at M5	31.987 – 32.000 (1.2593 – 1.2598)	31.96 (1.258)
Bushing-to-shaft clearance		0.007 – 0.041 (0.0003 – 0.0016)	0.08 (0.003)	

## CYLINDER/PISTON/CRANKSHAFT SPECIFICATIONS

Unit: mm (in)

ITEM		STANDARD	SERVICE LIMIT	
Cylinder	I.D.	74.000 – 74.015 (2.9134 – 2.9140)	74.10 (2.917)	
	Out-of-round	-	0.10 (0.004)	
	Taper	-	0.10 (0.004)	
	Warpage	-	0.05 (0.002)	
Piston, piston pin, piston ring	Piston O.D. at 10 mm (0.4 in) from bottom		73.970 – 73.990 (2.9122 – 2.9130)	73.85 (2.907)
	Piston pin hole I.D.		18.010 – 18.016 (0.7091 – 0.7093)	18.03 (0.710)
	Piston pin O.D.		17.994 – 18.000 (0.7084 – 0.7087)	17.99 (0.708)
	Piston-to-piston pin clearance		0.010 – 0.022 (0.0004 – 0.0009)	0.05 (0.002)
	Piston ring end gap	Top	0.15 – 0.30 (0.006 – 0.012)	0.5 (0.02)
		Second	0.30 – 0.45 (0.012 – 0.018)	0.6 (0.02)
		Oil (side rail)	0.20 – 0.70 (0.008 – 0.028)	0.9 (0.04)
	Piston ring-to-ring groove clearance	Top	0.025 – 0.055 (0.0010 – 0.0022)	0.10 (0.004)
Second		0.015 – 0.045 (0.0006 – 0.0018)	0.10 (0.004)	
Cylinder-to-piston clearance		0.010 – 0.045 (0.0004 – 0.0018)	0.10 (0.004)	
Crankshaft	Connecting rod side clearance		0.15 – 0.30 (0.006 – 0.012)	0.40 (0.016)
	Crankpin bearing oil clearance		0.028 – 0.046 (0.0011 – 0.0018)	0.06 (0.002)
	Main journal bearing oil clearance	1, 4	0.012 – 0.030 (0.0005 – 0.0012)	0.06 (0.002)
		2, 3	0.020 – 0.038 (0.0008 – 0.0015)	0.06 (0.002)
	Runout		-	0.03 (0.001)
	Crankpin and main journal	Taper	-	0.003 (0.0001)
Out-of-round		-	0.005 (0.0002)	

## FINAL DRIVE SPECIFICATIONS

Unit: mm (in)

ITEM		STANDARD	SERVICE LIMIT
Recommended final drive oil		Hypoid gear oil, SAE #80	-
Final drive oil capacity	After draining	120 cm <sup>3</sup> (4.1 US oz, 4.2 Imp oz)	-
	After disassembly	150 cm <sup>3</sup> (5.1 US oz, 5.3 Imp oz)	-
Final drive gear backlash		0.05 – 0.15 (0.002 – 0.006)	0.30 (0.012)
Backlash difference between measurements		-	0.10 (0.004)
Final drive gear assembly preload		0.2 – 1 N·m (2 – 10 kgf·cm, 1.7 – 8.7 lbf·in)	-

## FRONT WHEEL/SUSPENSION/STEERING SPECIFICATIONS

Unit: mm (in)

ITEM		STANDARD	SERVICE LIMIT
Minimum tire tread depth		-	1.5 (0.06)
Cold tire pressure	Up to 90 kg (200 lbs) load	250 kPa (2.50 kgf/cm <sup>2</sup> , 36 psi)	-
	Up to maximum weight capacity	250 kPa (2.50 kgf/cm <sup>2</sup> , 36 psi)	-
Axle runout		-	0.20 (0.008)
Wheel rim runout	Radial	-	2.0 (0.08)
	Axial	-	2.0 (0.06)
Wheel balance weight		-	60 g (2.1 oz) max.
Fork	Spring free length		335.3 (13.20)
	Tube runout		-
	Recommended fluid		Pro-Honda Suspension Fluid SS-8
	Fluid level		128 (5.0)
	Fluid capacity	Left	529 ± 2.5 cm <sup>3</sup> (17.9 ± 0.08 US oz, 18.6 ± 0.09 Imp oz)
Right		485 ± 2.5 cm <sup>3</sup> (16.4 ± 0.08 US oz, 17.1 ± 0.09 Imp oz)	-
Steering head bearing preload		8.8 – 13.7 N (0.9 – 1.4 kgf, 2.0 – 3.1 lbf)	-

## REAR WHEEL/SUSPENSION SPECIFICATIONS

Unit: mm (in)

ITEM		STANDARD	SERVICE LIMIT
Minimum tire tread depth		-	2.0 (0.08)
Cold tire pressure	Up to 90 kg (200 lbs) load	280 kPa (2.80 kgf/cm <sup>2</sup> , 41 psi)	-
	Up to maximum weight capacity	280 kPa (2.80 kgf/cm <sup>2</sup> , 41 psi)	-
Wheel rim runout	Radial	-	2.0 (0.08)
	Axial	-	2.0 (0.08)
Wheel balance weight		-	70 g (2.5 oz) max.

## GENERAL INFORMATION

# BRAKE SYSTEM SPECIFICATIONS

Unit: mm (in)

ITEM			STANDARD	SERVICE LIMIT	
Specified brake fluid			DOT 4	-	
Front	Brake disc thickness		4.5 (0.18)	3.5 (0.14)	
	Brake disc runout		-	0.30 (0.012)	
	Master cylinder I.D.		14.000 - 14.043 (0.5512 - 0.5529)	14.055 (0.5533)	
	Master piston O.D.		13.957 - 13.984 (0.5495 - 0.5506)	13.945 (0.5490)	
	Caliper cylinder I.D.	Left	Upper	22.650 - 22.700 (0.8917 - 0.8937)	22.71 (0.894)
			Center	27.000 - 27.050 (1.0630 - 1.0650)	27.06 (1.065)
			Lower	22.650 - 22.700 (0.8917 - 0.8937)	22.71 (0.894)
		Right	Upper	25.400 - 25.450 (1.0000 - 1.0020)	25.46 (1.002)
			Center	25.400 - 25.450 (1.0000 - 1.0020)	25.46 (1.002)
			Lower	22.650 - 22.700 (0.8917 - 0.8937)	22.71 (0.894)
	Caliper piston O.D.	Left	Upper	22.585 - 22.618 (0.8892 - 0.8905)	22.56 (0.888)
			Center	26.935 - 26.968 (1.0604 - 1.0617)	26.91 (1.059)
			Lower	22.585 - 22.618 (0.8892 - 0.8905)	22.56 (0.888)
Right		Upper	25.335 - 25.368 (0.9974 - 0.9987)	25.31 (0.996)	
		Center	25.335 - 25.368 (0.9974 - 0.9987)	25.31 (0.996)	
		Lower	22.585 - 22.618 (0.8892 - 0.8905)	22.56 (0.888)	
Rear	Brake disc thickness		11.0 (0.43)	10.0 (0.39)	
	Brake disc runout		-	0.30 (0.012)	
	Pedal master cylinder I.D.		17.460 - 17.503 (0.6874 - 0.6891)	17.515 (0.6896)	
	Pedal master piston O.D.		17.417 - 17.444 (0.6857 - 0.6868)	17.405 (0.6852)	
	Secondary master cylinder I.D.		14.000 - 14.043 (0.5512 - 0.5529)	14.055 (0.5533)	
	Secondary master piston O.D.		13.957 - 13.984 (0.5495 - 0.5506)	13.945 (0.5490)	
	Caliper cylinder I.D.	Upper	22.650 - 22.700 (0.8917 - 0.8937)	22.71 (0.894)	
		Center	27.000 - 27.050 (1.0630 - 1.0650)	27.06 (1.065)	
		Lower	22.650 - 22.700 (0.8917 - 0.8937)	22.71 (0.894)	
	Caliper piston O.D.	Upper	22.585 - 22.618 (0.8892 - 0.8905)	22.56 (0.888)	
		Center	26.935 - 26.968 (1.0604 - 1.0617)	26.91 (1.059)	
		Lower	22.585 - 22.618 (0.8892 - 0.8905)	22.56 (0.888)	

# BATTERY/CHARGING SYSTEM SPECIFICATIONS

ITEM			STANDARD	SERVICE LIMIT
Battery	Capacity		12 V - 18 Ah	-
	Current leakage		5 mA max.	-
	Voltage (20° C/68° F)	Fully charged	13.0 - 13.2 V	-
		Needs charging	Below 12.3 V	-
	Charging current	Normal	1.8 A x 5 - 10 h	-
		Quick	9.0 A x 1.0 h	-
Alternator	Capacity		1 kW @ 2,400 rpm	-
	Stator coil resistance (20° C/68° F)		0.07 - 0.09 Ω	-
	Rotor coil resistance (20° C/68° F)		2.5 - 2.9 Ω	-
	Rotor coil slip ring O.D.		22.7 mm (0.89 in)	21.2 mm (0.83 in)

## IGNITION SYSTEM SPECIFICATIONS

ITEM		SPECIFICATIONS
Spark plug	Standard	BKR6E-11 (NGK), K20PR-U11 (DENSO)
	For cold climate (below 5°C/41°F)	BKR5E-11 (NGK), K16PR-U11 (DENSO)
	For extended high speed riding	BKR7E-11 (NGK), K22PR-U11 (DENSO)
Spark plug gap		1.0 – 1.1 mm (0.039 – 0.043 in)
Ignition coil signal peak voltage		2.5 – 5.0 V
Ignition pulse generator peak voltage		0.7 V minimum
Ignition timing ("F" mark)		0° BTDC at idle

## STARTER/REVERSE SYSTEM SPECIFICATIONS

ITEM		STANDARD	SERVICE LIMIT
Starter/reverse motor brush length		12.5 mm (0.49 in)	6.0 mm (0.24 in)
Reverse resistor resistance (20°C/68°F)	Red and Black terminal	0.20 – 0.25 Ω	-
	White terminal	0.15 – 0.20 Ω	-

## LIGHTS/METERS/SWITCHES SPECIFICATIONS

ITEM		SPECIFICATIONS
Bulbs	Headlight (high beam)	12 V – 55 W x 2
	Headlight (low beam)	12 V – 55 W x 2
	Brake/taillight	12 V – 21/5 W x 6
	License light	12 V – 3CP (5W)
	Front turn signal/running light	12 V – 21/5 W x 2
	Rear turn signal light	12 V – 21 W x 2
	Left panel switch light	12 V – 1.4 W x 4
	Left handlebar switch light	12 V – 1.4 W x 7
Fuse	Right handlebar switch light	12 V – 1.4 W x 4
	Main fuse A	30A
	Main fuse B	100A
	Reverse speed limiter fuse	70A
	Sub-fuse	20A x 3, 15A x 8, 10A x 3, 5A x 4 (ABS model: 5A x 5)
ECT sensor resistance	Modulator fuse (ABS model)	30 A x 2
	At 80°C (176°F)	47 – 57 Ω
	At 120°C (248°F)	14 – 18 Ω

## CRUISE CONTROL SYSTEM SPECIFICATIONS

ITEM		STANDARD	SERVICE LIMIT
Cruise actuator coil resistance (20°C/68°F)	Clutch coil	35 – 45 Ω	-
	Step motor coil	3 – 7 Ω	-

## GENERAL INFORMATION

# STANDARD TORQUE VALUES

FASTENER TYPE	TORQUE N·m (kgf·m, lbf·ft)	FASTENER TYPE	TORQUE N·m (kgf·m, lbf·ft)
5 mm bolt and nut	5 (0.5, 3.6)	5 mm screw	4 (0.4, 2.9)
6 mm bolt and nut	10 (1.0, 7)	6 mm screw	9 (0.9, 6.5)
8 mm bolt and nut	22 (2.2, 16)	6 mm flange bolt (8 mm head, small flange)	10 (1.0, 7)
10 mm bolt and nut	34 (3.5, 25)	6 mm flange bolt (8 mm head, large flange)	12 (1.2, 9)
12 mm bolt and nut	54 (5.5, 40)	6 mm flange bolt (10 mm head) and nut	12 (1.2, 9)
		8 mm flange bolt and nut	26 (2.7, 20)
		10 mm flange bolt and nut	39 (4.0, 29)

## ENGINE & FRAME TORQUE VALUES

- Torque specifications listed below are for important fasteners.
- Others should be tightened to standard torque values listed above.

### NOTE:

1. Apply oil to the threads and seating surface.
2. Apply grease to the threads.
3. Apply locking agent to the threads.
4. Apply sealant to the threads.
5. Apply brake fluid to the threads.
6. Lock nut: replace with a new one and stake it.
7. ALOC bolt or screw: replace with a new one.
8. One-way bolt: replace with a new one.
9. Left-hand threads.
10. U-nut.

## ENGINE

### MAINTENANCE

ITEM	Q'TY	THREAD DIA. (mm)	TORQUE N·m (kgf·m, lbf·ft)	REMARKS
Spark plug	6	14	18 (1.8, 13)	
Timing hole cap	1	45	18 (1.8, 13)	NOTE 2
Engine oil filter cartridge	1	20	26 (2.7, 20)	NOTE 1
Engine oil drain bolt	1	14	34 (3.5, 25)	

### LUBRICATION SYSTEM

ITEM	Q'TY	THREAD DIA. (mm)	TORQUE N·m (kgf·m, lbf·ft)	REMARKS
Oil pressure switch	1	PT 1/8	12 (1.2, 9)	NOTE 4
Oil strainer bolt	1	6	12 (1.2, 9)	NOTE 3
Oil pump assembly bolt	3	6	13 (1.3, 9)	

### FUEL SYSTEM (Programmed Fuel Injection)

ITEM	Q'TY	THREAD DIA. (mm)	TORQUE N·m (kgf·m, lbf·ft)	REMARKS
Fuel hose joint bolt	6	6	10 (1.0, 7)	
Fuel rail mounting bolt	6	6	10 (1.0, 7)	
Pressure regulator nut	1	18	27 (2.8, 20)	
Pressure regulator stay bolt	2	6	10 (1.0, 7)	
Fuel rail banjo bolt	1	12	33 (3.4, 25)	
Sealing bolt	1	6	12 (1.2, 9)	
PAIR check valve cover bolt	12	5	5 (0.5, 3.6)	
Knock sensor	2	12	31 (3.2, 23)	
Engine coolant temperature (ECT) sensor	1	12	25 (2.5, 18)	
O <sub>2</sub> sensor	2	12	25 (2.5, 18)	

## GENERAL INFORMATION

### COOLING SYSTEM

ITEM	Q'TY	THREAD DIA. (mm)	TORQUE N·m (kgf·m, lbf·ft)	REMARKS
Water pump cover sealing plate bolt	2	6	13 (1.3, 9)	
Water pump cover bolt	3	6	13 (1.3, 9)	

### CYLINDER HEAD/VALVE

ITEM	Q'TY	THREAD DIA. (mm)	TORQUE N·m (kgf·m, lbf·ft)	REMARKS
Cylinder head bolt	16	9	44 (4.5, 33)	NOTE 1
Left cam chain guide washer bolt	1	6	12 (1.2, 9)	
Cam chain tensioner pivot bolt	3	6	12 (1.2, 9)	
Ignition pulse generator rotor bolt	1	10	59 (6.0, 43)	NOTE 1
Front crankcase cover bolt	12	6	12 (1.2, 9)	
Cam sprocket bolt	4	7	25 (2.6, 19)	NOTE 3
Camshaft holder bolt	16	6	12 (1.2, 9)	NOTE 1
Cam chain tensioner lifter mounting bolt	4	6	12 (1.2, 9)	
Cam chain tensioner lifter sealing bolt	2	6	12 (1.2, 9)	
Cylinder head cover bolt	11	6	10 (1.0, 7)	
Cylinder head side cover bolt	10	6	10 (1.0, 7)	
Sealing bolt (oil passage)	6	14	25 (2.5, 18)	NOTE 3
Sealing bolt (secondary air passage)	6	8	22 (2.2, 16)	NOTE 3

### CLUTCH

ITEM	Q'TY	THREAD DIA. (mm)	TORQUE N·m (kgf·m, lbf·ft)	REMARKS
Clutch slave cylinder bleed valve	1	8	9 (0.9, 6.5)	
Clutch outer lock nut	1	40	186 (19.0, 137)	NOTE 3, 6
Clutch center lock nut	1	22	127 (13.0, 94)	NOTE 1, 6

### GEARSHIFT LINKAGE/TRANSMISSION

ITEM	Q'TY	THREAD DIA. (mm)	TORQUE N·m (kgf·m, lbf·ft)	REMARKS
Shift drum stopper arm pivot bolt	1	6	12 (1.2, 9)	
Shift drum joint bolt	1	8	27 (2.8, 20)	NOTE 3
Mainshaft bearing lock nut	1	30	186 (19.0, 137)	NOTE 1, 6
Countershaft setting plate bolt	3	6	12 (1.2, 9)	NOTE 3
Mainshaft setting plate bolt	2	8	26 (2.7, 20)	NOTE 3
Shift drum reverse lock cam bolt	1	6	12 (1.2, 9)	NOTE 3
Shift drum bearing setting plate bolt	2	6	12 (1.2, 9)	NOTE 3
Gearshift spindle arm bolt	1	8	25 (2.5, 18)	
Gearshift spindle return spring pin	1	8	25 (2.5, 18)	
Final drive gear lock nut	1	22	186 (19.0, 137)	NOTE 1, 6, 9
Alternator drive gear bolt	6	8	25 (2.6, 19)	NOTE 1
Oil pump driven sprocket bolt	1	6	18 (1.8, 13)	NOTE 3
Starter clutch bolt	1	12	74 (7.5, 54)	NOTE 9
Primary driven gear bearing setting plate bolt (rear crankcase cover)	4	6	12 (1.2, 9)	NOTE 3
Rear crankcase cover bolt	16	8	24 (2.4, 17)	
Output shaft lock nut	1	30	186 (19.0, 137)	NOTE 6
Output shaft bearing holder bolt	3	8	28 (2.9, 21)	

### CYLINDER/PISTON/CRANKSHAFT

ITEM	Q'TY	THREAD DIA. (mm)	TORQUE N·m (kgf·m, lbf·ft)	REMARKS
Connecting rod bearing cap nut	12	8	31 (3.2, 23)	NOTE 1
Crankshaft main journal bearing cap bolt	8	12	20 (2.0, 14) + 45°	NOTE 1
Left crankcase bolt	4	8	25 (2.6, 19)	
Right crankcase bolt	8	10	34 (3.5, 25)	NOTE 1
	11	6	12 (1.2, 9)	
Sealing bolt (left crankcase)	4	20	44 (4.5, 33)	NOTE 3

## GENERAL INFORMATION

### BATTERY/CHARGING SYSTEM

ITEM	Q'TY	THREAD DIA. (mm)	TORQUE N·m (kgf·m, lbf·ft)	REMARKS
Alternator mounting bolt	3	8	29 (3.0, 22)	

### IGNITION SYSTEM

ITEM	Q'TY	THREAD DIA. (mm)	TORQUE N·m (kgf·m, lbf·ft)	REMARKS
Ignition pulse generator bolt	2	6	12 (1.2, 9)	NOTE 3

### STARTER/REVERSE SYSTEM

ITEM	Q'TY	THREAD DIA. (mm)	TORQUE N·m (kgf·m, lbf·ft)	REMARKS
Starter motor mounting bolt	3	8	29 (3.0, 22)	
Reverse switch	1	10	12 (1.2, 9)	
Shift drum lock arm bolt	1	6	12 (1.2, 9)	NOTE 3
Reverse shifter shaft bolt	1	6	14 (1.4, 10)	NOTE 3
Reverse shifter cable holder bolt	2	6	12 (1.2, 9)	NOTE 3
Reverse switch terminal nut	1	4	2 (0.2, 1.4)	

**FRAME**

**FRAME/BODY PANELS/EXHAUST SYSTEM**

ITEM	Q'TY	THREAD DIA. (mm)	TORQUE N·m (kgf·m, lbf·ft)	REMARKS
Center fresh air visor socket bolt	2	5	1 (0.1, 0.7)	
Exhaust pipe joint nut	12	6	12 (1.2, 9)	
Exhaust pipe mounting bolt	2	8	26 (2.7, 20)	
Exhaust pipe band bolt	2	8	26 (2.7, 20)	
Muffler band bolt	4	8	26 (2.7, 20)	
Front exhaust pipe protector bolt	2	6	12 (1.2, 9)	
Rear exhaust pipe protector bolt	2	6	14 (1.4, 10)	
Saddlebag/trunk stay bolt	6	8	26 (2.7, 20)	

**MAINTENANCE**

ITEM	Q'TY	THREAD DIA. (mm)	TORQUE N·m (kgf·m, lbf·ft)	REMARKS
Air cleaner cover screw	7	5	1 (0.1, 0.7)	
Final drive oil filler cap	1	30	12 (1.2, 9)	
Final drive oil drain bolt	1	14	20 (2.0, 14)	

**COOLING SYSTEM**

ITEM	Q'TY	THREAD DIA. (mm)	TORQUE N·m (kgf·m, lbf·ft)	REMARKS
Radiator assembly mounting bolt	4	6	14 (1.4, 10)	

**ENGINE MOUNTING**

ITEM	Q'TY	THREAD DIA. (mm)	TORQUE N·m (kgf·m, lbf·ft)	REMARKS
Engine hanger bolt				
– front/rear	4	12	64 (6.5, 47)	
– center	2	10	39 (4.0, 29)	
Left engine hanger adjusting bolt				
– front	1	22	2 (0.2, 1.4)	
– center	1	20	4 (0.4, 2.9)	
– rear	1	22	4 (0.4, 2.9)	
Left engine hanger adjusting bolt lock nut				
– front/rear	2	22	54 (5.5, 40)	
– center	1	20	54 (5.5, 40)	

**CLUTCH**

ITEM	Q'TY	THREAD DIA. (mm)	TORQUE N·m (kgf·m, lbf·ft)	REMARKS
Clutch master cylinder reservoir cap screw	2	4	2 (0.2, 1.4)	
Clutch lever pivot bolt	1	6	1 (0.1, 0.7)	
Clutch lever pivot nut	1	6	6 (0.6, 4.3)	
Clutch switch screw	1	4	1 (0.1, 0.7)	
Clutch cruise switch screw	1	4	1 (0.1, 0.7)	
Clutch master cylinder holder bolt	2	6	12 (1.2, 9)	
Clutch hose oil bolt	2	10	34 (3.5, 25)	

**FINAL DRIVE**

ITEM	Q'TY	THREAD DIA. (mm)	TORQUE N·m (kgf·m, lbf·ft)	REMARKS
Pinion retainer	1	70	147 (15.0, 108)	NOTE 1
Pinion retainer lock tab bolt	1	6	10 (1.0, 7)	
Pinion joint nut	1	16	108 (11.0, 80)	NOTE 3
Final side flange screw	2	6	9 (0.9, 6.5)	NOTE 7
Gear case cover bolt	2	10	62 (6.3, 46)	NOTE 3
	6	8	25 (2.6, 19)	NOTE 3
Final gear case assembly mounting nut	4	12	88 (9.0, 65)	



## GENERAL INFORMATION

### FRONT WHEEL/SUSPENSION/STEERING

ITEM	Q'TY	THREAD DIA. (mm)	TORQUE N·m (kgf·m, lbf·ft)	REMARKS
Handlebar weight mounting screw	2	6	10 (1.0, 7)	NOTE 7
Handlebar mounting bolt	4	10	26 (2.7, 20)	
Front brake disc bolt	12	6	20 (2.0, 14)	NOTE 7
Front pulser ring bolt (ABS model only)	3	5	8 (0.8, 5.8)	NOTE 7
Front axle bolt	1	14	59 (6.0, 43)	
Front axle holder bolt	4	8	22 (2.2, 16)	
Fork center bolt	2	8	20 (2.0, 14)	NOTE 3
Fork damper lock nut	1	10	20 (2.0, 14)	
Fork cap	2	42	23 (2.3, 17)	
Anti-dive plunger case bolt	2	5	4 (0.4, 2.9)	NOTE 7
Fork top bridge pinch bolt	2	8	26 (2.7, 20)	
Fork bottom bridge pinch bolt	4	8	29 (3.0, 22)	
Brake hose oil bolt (anti-dive)	1	10	34 (3.5, 25)	
Steering bearing adjustment nut	1	26	27 (2.8, 20)	NOTE 1
Steering bearing adjustment nut lock nut	1	26	-	See page 13-41
Steering stem nut	1	24	103 (10.5, 76)	

### REAR WHEEL/SUSPENSION

ITEM	Q'TY	THREAD DIA. (mm)	TORQUE N·m (kgf·m, lbf·ft)	REMARKS
Rear wheel nut	5	12	108 (11.0, 80)	
Rear pulser ring bolt (ABS model only)	6	5	8 (0.8, 5.8)	NOTE 7
Shock absorber mounting nut	2	10	42 (4.3, 31)	NOTE 10
Suspension level actuator mounting bolt	2	8	26 (2.7, 20)	
Shock arm-to-swingarm nut	1	12	64 (6.5, 47)	NOTE 10
Shock arm-to-shock link nut	1	12	64 (6.5, 47)	NOTE 10
Shock link-to-frame nut	1	12	64 (6.5, 47)	NOTE 10
Swingarm right pivot bolt	1	36	108 (11.0, 80)	
Swingarm left pivot bolt	1	36	34 (3.5, 25)	
Swingarm left pivot lock nut	1	36	108 (11.0, 80)	

**BRAKE SYSTEM**

ITEM	Q'TY	THREAD DIA. (mm)	TORQUE N·m (kgf·m, lbf·ft)	REMARKS
Brake caliper bleed valve	6	8	6 (0.6, 4.3)	
Front fork anti-dive plunger bleed valve	1	8	6 (0.6, 4.3)	
Front master cylinder reservoir cap screw	2	4	2 (0.2, 1.4)	
Brake pad pin	3	10	18 (1.8, 13)	
Brake hose oil bolt	12	10	34 (3.5, 25)	
Brake lever pivot bolt	1	6	1 (0.1, 0.7)	
Brake lever pivot nut	1	6	6 (0.6, 4.3)	
Front brake light/cruise cancel switch screw	1	4	1 (0.1, 0.7)	
Front master cylinder holder bolt	2	6	12 (1.2, 9)	
Rear master cylinder reservoir mounting bolt	1	6	12 (1.2, 9)	
Rear master cylinder switch plate lock nut	1	8	18 (1.8, 13)	
Rear master cylinder joint nut	1	8	18 (1.8, 13)	
Rear master cylinder mounting bolt	2	6	12 (1.2, 9)	
Brake pedal pinch bolt	1	8	26 (2.7, 20)	
Rear brake light/cruise cancel switch holder screw	2	4	2 (0.2, 1.4)	NOTE 3
Secondary master cylinder mounting bolt	2	8	31 (3.2, 23)	NOTE 7
Front brake caliper bracket pin	2	8	13 (1.3, 9)	NOTE 3
Front brake caliper pin	2	8	23 (2.3, 17)	
Front brake caliper assembly bolt	6	8	32 (3.3, 24)	NOTE 7
Left front brake caliper lower mounting bolt	1	8	31 (3.2, 23)	NOTE 7
Left front brake caliper-to-secondary master cylinder joint bolt	1	8	25 (2.6, 19)	NOTE 7
Right front brake caliper mounting bolt	2	8	31 (3.2, 23)	NOTE 7
Rear brake caliper bracket pin	1	8	23 (2.3, 17)	NOTE 3
Rear brake caliper pin bolt	1	12	27 (2.8, 20)	
Rear brake caliper assembly bolt	3	8	32 (3.3, 24)	NOTE 7
Rear brake disc screw	2	6	9 (0.9, 6.5)	NOTE 7
Rear brake caliper mounting bolt	2	10	45 (4.6, 33)	NOTE 7
Proportional control valve mounting bolt	2	6	12 (1.2, 9)	
Delay valve mounting bolt	1	6	12 (1.2, 9)	
Brake pipe joint nut (ABS model)	28	10	17 (1.7, 12)	NOTE 5
(Non-ABS model)	20	10	17 (1.7, 12)	NOTE 5
Brake hose clamp bolt ('01 - '03:)	9	6	12 (1.2, 9)	
(After '03)	8	6	12 (1.2, 9)	
Rear brake hose guide bolt (After '03)	2	6	12 (1.2, 9)	
Brake hose joint attaching bolt	7	6	12 (1.2, 9)	
Wheel speed sensor bolt (ABS model only)	4	6	12 (1.2, 9)	
Modulator mounting screw (ABS model only)	6	6	12 (1.2, 9)	
Ignition coil/modulator stay bolt	2	6	12 (1.2, 9)	
Modulator brake pipe joint bolt (ABS model only)	8	10	34 (3.5, 25)	

## GENERAL INFORMATION

### LIGHTS/METERS/SWITCHES

ITEM	Q'TY	THREAD DIA. (mm)	TORQUE N·m (kgf·m, lbf·ft)	REMARKS
Side stand switch bolt	1	6	10 (1.0, 7)	
Ignition switch mounting bolt	2	8	25 (2.5, 18)	NOTE 8

### AUDIO SYSTEM

ITEM	Q'TY	THREAD DIA. (mm)	TORQUE N·m (kgf·m, lbf·ft)	REMARKS
Antenna base mounting bolt	2	6	14 (1.4, 10)	

### OTHERS

ITEM	Q'TY	THREAD DIA. (mm)	TORQUE N·m (kgf·m, lbf·ft)	REMARKS
Bank angle sensor screw (sensor-to-stay)	2	4	2 (0.2, 1.4)	
Side stand pivot bolt	1	10	10 (1.0, 7)	
Side stand pivot lock nut	1	10	29 (3.0, 22)	
Side stand bracket bolt	2	10	44 (4.5, 33)	
	1	8	26 (2.7, 20)	
Left center stand pivot bolt	1	10	54 (5.5, 40)	NOTE 7
Right center stand pivot bolt	1	10	54 (5.5, 40)	NOTE 7, 9
Driver footpeg mounting bolt	4	8	26 (2.7, 20)	
Passenger footrest mounting bolt	4	8	26 (2.7, 20)	
Gearshift pedal pivot bolt	1	8	26 (2.7, 20)	

# LUBRICATION & SEAL POINTS

## ENGINE

LOCATION	MATERIAL	REMARKS
Crankcase mating surface Rear crankcase cover gasket mating surface (case side) Gearshift linkage cover gasket mating surface (case side) Front crankcase cover gasket mating surface (case side) Cylinder head semi-circular edges Oil pressure switch threads	Sealant	Coating area 11 – 21 Coating area 10 – 21 Coating area 10 – 7  Coating area 8 – 23 Coating area 8 – 28 Do not apply to the sensor head
Crankshaft main journal bearing sliding surface Crankpin bearing sliding surface Valve stem sliding surface Valve lifter outer surface Camshaft journals, thrust surfaces and cam lobes Clutch outer friction spring M2/3, C4, C5 gear shift fork grooves Starter drive gear holder stopper pin and collar Reverse shifter shaft sliding surface Reverse shifter lead grooves Reverse shifter gear splines Starter reduction gear shaft outer surface Reverse shifter thrust needle bearing	Molybdenum oil solution (a mixture of 1/2 engine oil and 1/2 molybdenum disulfide grease)	
Engine oil filter cartridge threads and seating surface Camshaft holder bolt threads and seating surface Cylinder head 9 mm bolt threads and seating surface Cylinder head 6 mm bolt threads and seating surface Ignition pulse generator rotor bolt threads and seating surface Clutch lifter joint piece sliding surface Clutch disc lining surface Clutch center lock nut threads and seating surface Piston pin outer surface Piston outer surface and piston ring whole surface Crankshaft main journal bearing cap bolt threads and seating surface Connecting rod bearing cap nut threads and seating surface Shift fork shaft Transmission bushing Mainshaft bearing lock nut threads and seating surface Final drive gear lock nut threads and seating surface Right crankcase 10 mm bolt threads Alternator drive gear bolt threads and seating surface Starter sprag clutch contacting surfaces Each gear tooth and sliding surface Each bearing rotating area Each O-ring whole surface	Engine oil	
Reverse spring bushing inner and outer surfaces Reverse shift drum lock arm pivot	Molybdenum disulfide grease	Apply 1 g Apply 0.5 g
Timing hole cap threads Reverse shifter shaft roller pin Oil seal lips	Multi-purpose grease	
Clutch lifter rod-to-slave cylinder piston contacting area	Silicone grease	

## GENERAL INFORMATION

LOCATION	MATERIAL	REMARKS
Oil filter boss threads (crankcase side) Oil strainer bolt threads Cylinder head 14 mm sealing bolt threads Cylinder head 10 mm sealing bolt threads Cam sprocket bolt threads Shift drum joint bolt threads Clutch outer lock nut threads Oil pump driven sprocket bolt threads Primary driven gear bearing setting plate bolt threads (rear crankcase cover) Mainshaft setting plate bolt threads Countershaft setting plate bolt threads Shift drum reverse lock cam bolt threads Shift drum bearing setting plate bolt threads Ignition pulse generator bolt threads Shift drum lock arm bolt threads Reverse shifter shaft bolt threads Reverse shifter cable holder bolt threads Left crankcase 20 mm sealing bolt threads	Locking agent	

**FRAME**

LOCATION	MATERIAL	REMARKS
Final gear case cover mating surface	Sealant	
Final gear case O-ring (3 places) Final gear case oil seal lips (2 places) Front wheel dust seal lips	Multi-purpose grease	
Windshield height adjusting lever pivot Windshield height adjusting holder sliding area Side stand pivot Center stand pivot Rider footpeg sliding area Passenger footrest sliding area Gearshift pedal link tie-rod ball joints Brake pedal pivot Throttle grip pipe flange and sliding surface Shock arm and link dust seal lips Shock arm and link needle bearings Swingarm pivot bearings Swingarm pivot dust seal lips	Multi-purpose grease with extreme pressure (Example: Shell Alvania EP2 or equivalent)	Apply 1 - 1.5 g per each pivot
Steering head bearings Steering head bearing dust seal lips	Urea based multi-purpose grease with extreme pressure (Example: Excelight EP2 manufactured by Kyodo Yushi Japan, Shell Stamina EP2 or equivalent)	
Gearshift pedal pivot	Shell Super Duty LF grease or equivalent	
Final drive pinion joint splines Final drive joint shaft dust seal lips Final drive shaft splines (output shaft and joint shaft)	Molybdenum disulfide grease	Apply 0.5 g Apply 1 g per each spline
Throttle cable outer inside Reverse control cable outer inside	Cable lubricant	
Trunk lid seal rubber seating surface Trunk panel seal rubber seating surface Trunk light cover rubber seating surface Saddle bag cover seal rubber seating surface Saddle bag panel seal rubber seating surface Handlebar grip rubber inside Brake caliper bracket retainer seating surface	Honda Bond A or equivalent	
Fuel tube joint O-ring (fuel pump) Final drive pinion retainer threads Steering bearing adjustment nut threads	Engine oil	
Clutch lever pivot Clutch lever joint piece-to-push rod contacting area Clutch master piston-to-push rod contacting area Anti-dive plunger tip Front brake lever pivot Front brake lever-to-master piston contacting area Rear master cylinder push rod boot groove Rear master piston-to-push rod contacting area Secondary master cylinder push rod boot groove Secondary master piston-to-push rod contacting area Brake caliper pad pin stopper ring Brake caliper pin boot inside	Silicone grease	
Clutch master piston and cups Brake master piston and cups Brake caliper piston and piston seals Brake pipe joint nut	DOT 4 brake fluid	
Fork dust seal and oil seal lips	Pro-Honda Suspension Fluid SS-8	

## GENERAL INFORMATION

LOCATION	MATERIAL	REMARKS
Final drive pinion joint nut threads Final gear case cover bolt threads Final gear case stud bolt threads (case side) Fork center bolt threads Fork anti-dive plunger case bolt threads Rear brake light/cruise cancel switch holder screw threads Secondary master cylinder push rod joint lock nut threads	Locking agent	

# CABLE & HARNESS ROUTING

**CONNECTORS:**

- Cruise cancel switch 2P (Blue)
- Ignition pulse generator 2P (Red)
- Reverse shift actuator 2P (White)
- Reverse limit switch 3P (Red)
- Gear position switch 6P (Black)

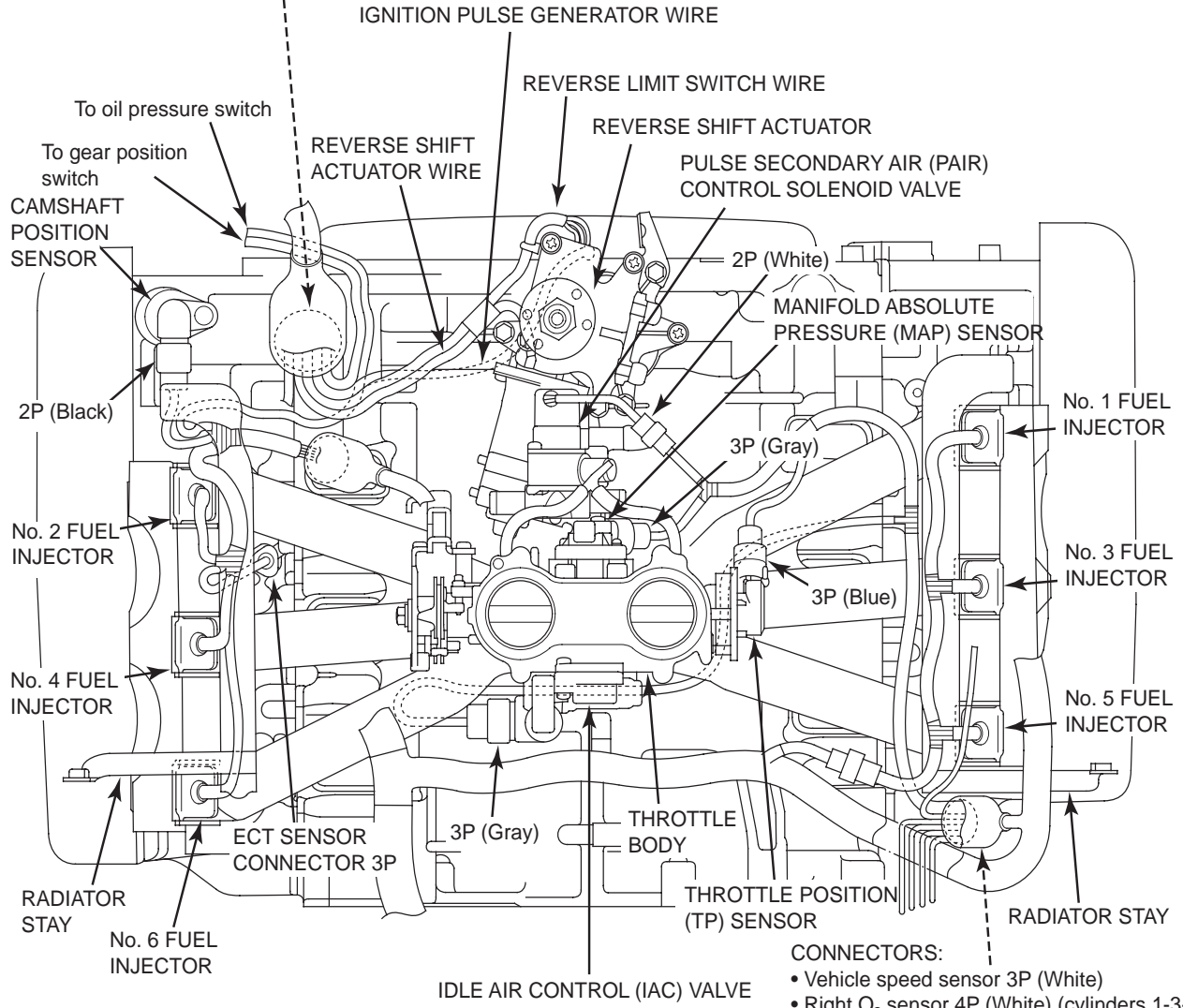

**CONNECTORS:**

- Vehicle speed sensor 3P (White)
- Right O<sub>2</sub> sensor 4P (White) (cylinders 1-3-5)
- Rear master cylinder brake light switch 3P (White)
- Rear master cylinder cruise cancel switch 2P (Red)
- Engine sub-wire harness 4P (Gray)



# GENERAL INFORMATION

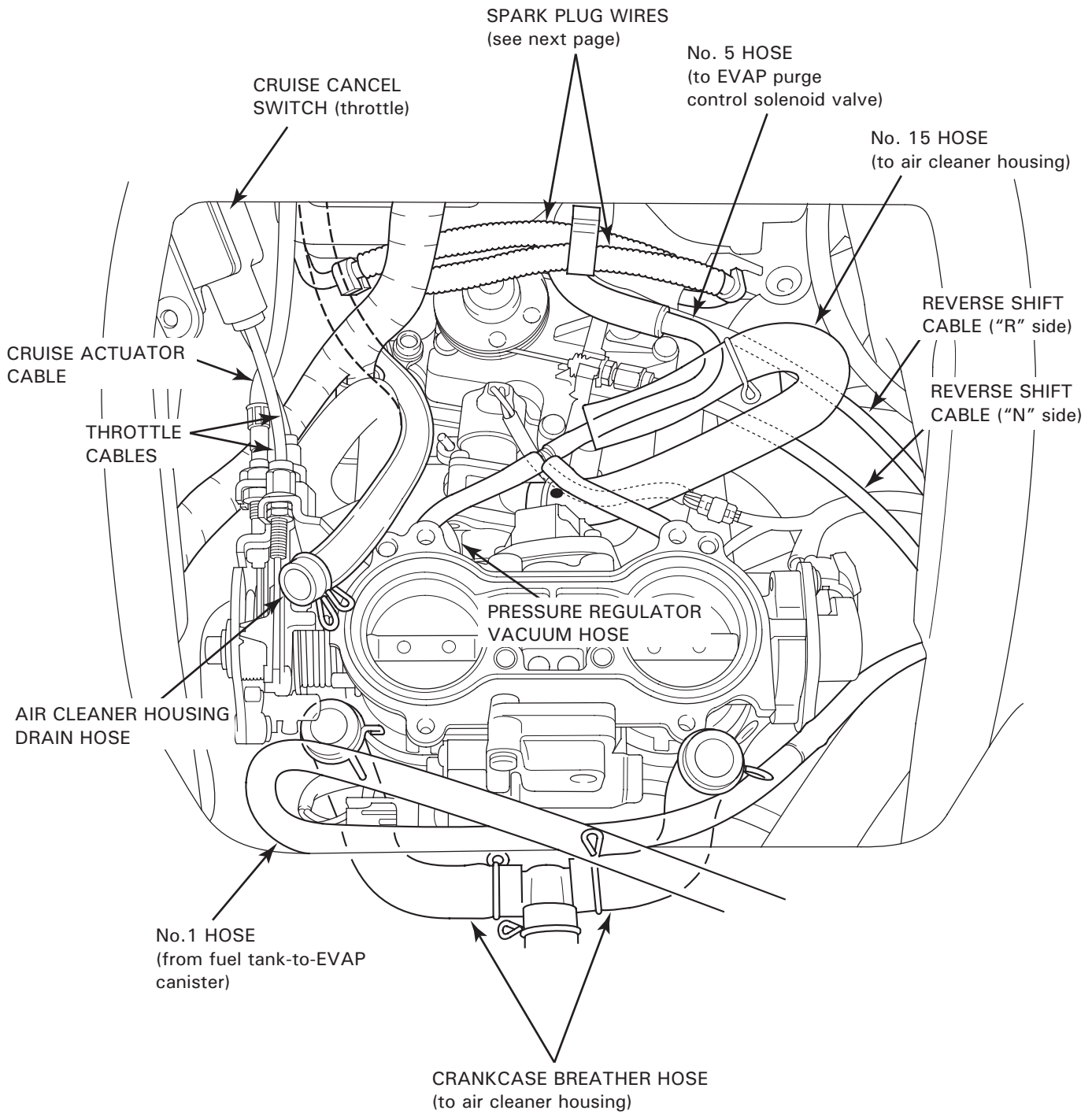

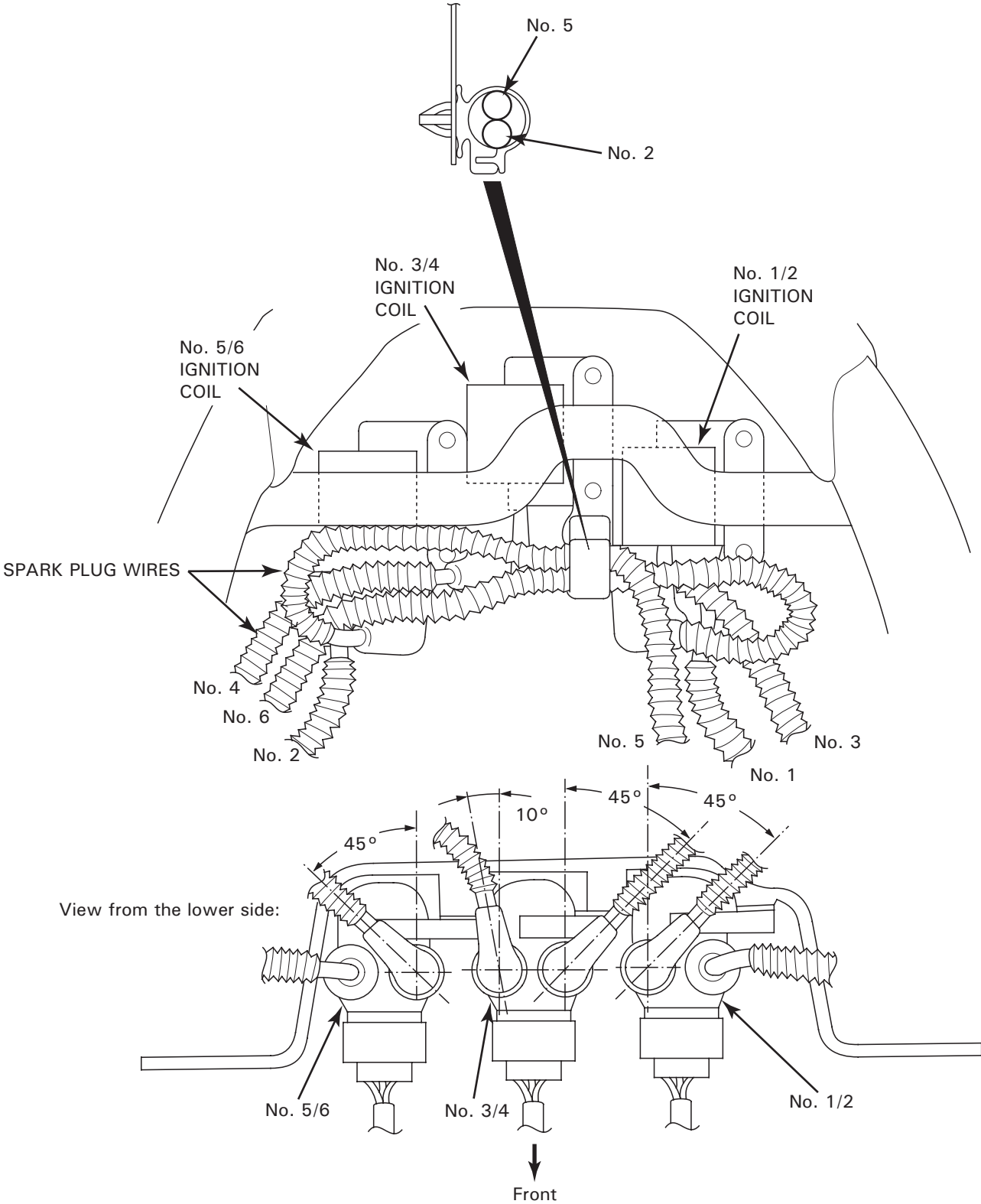

# GENERAL INFORMATION

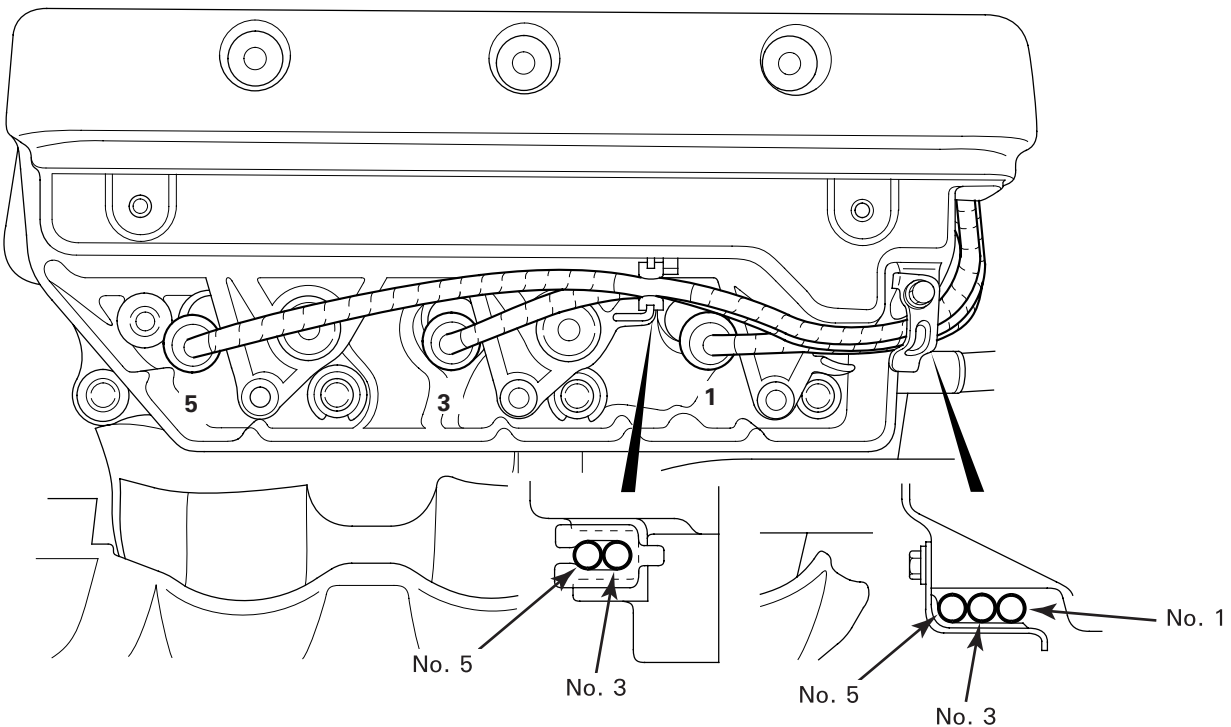
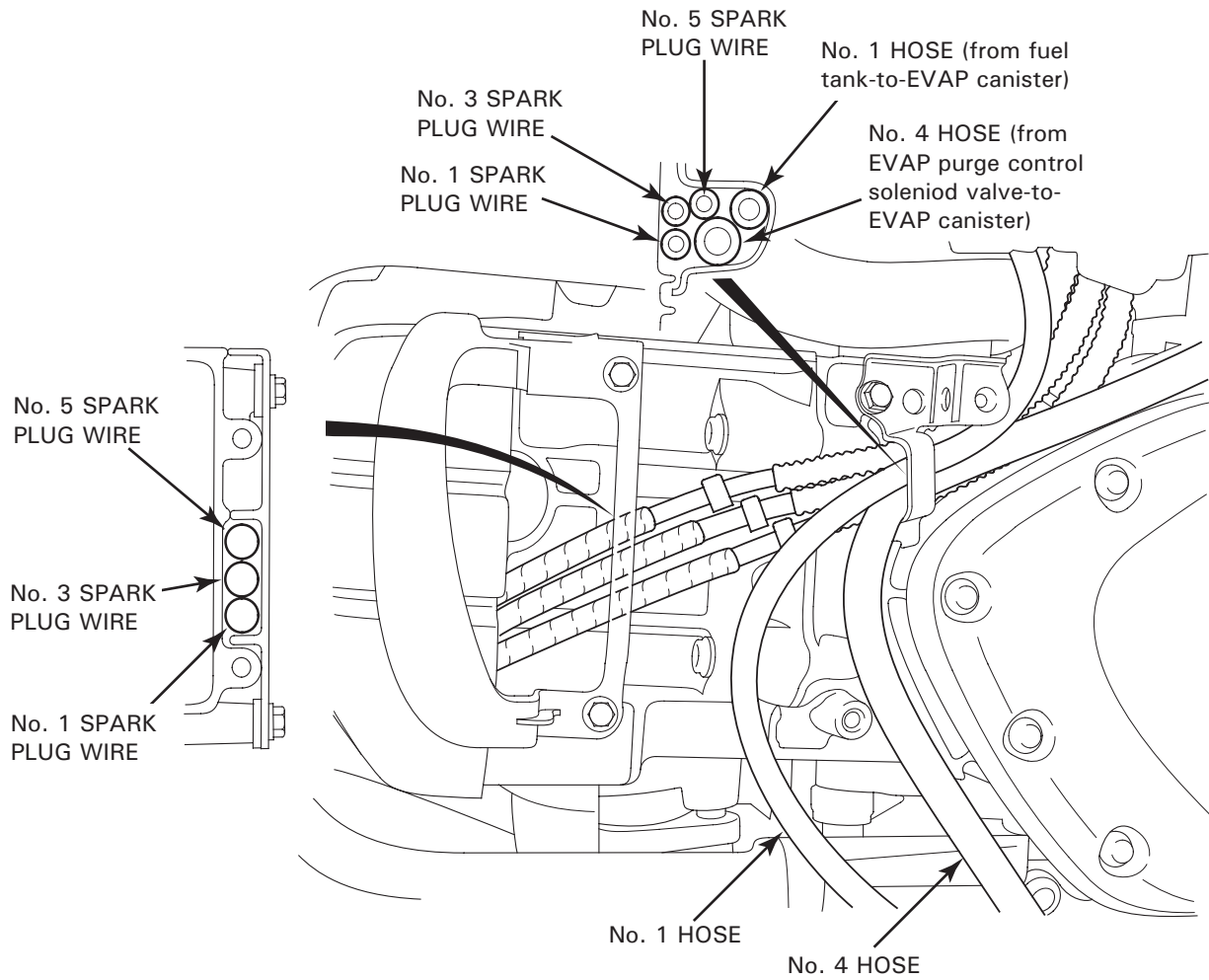

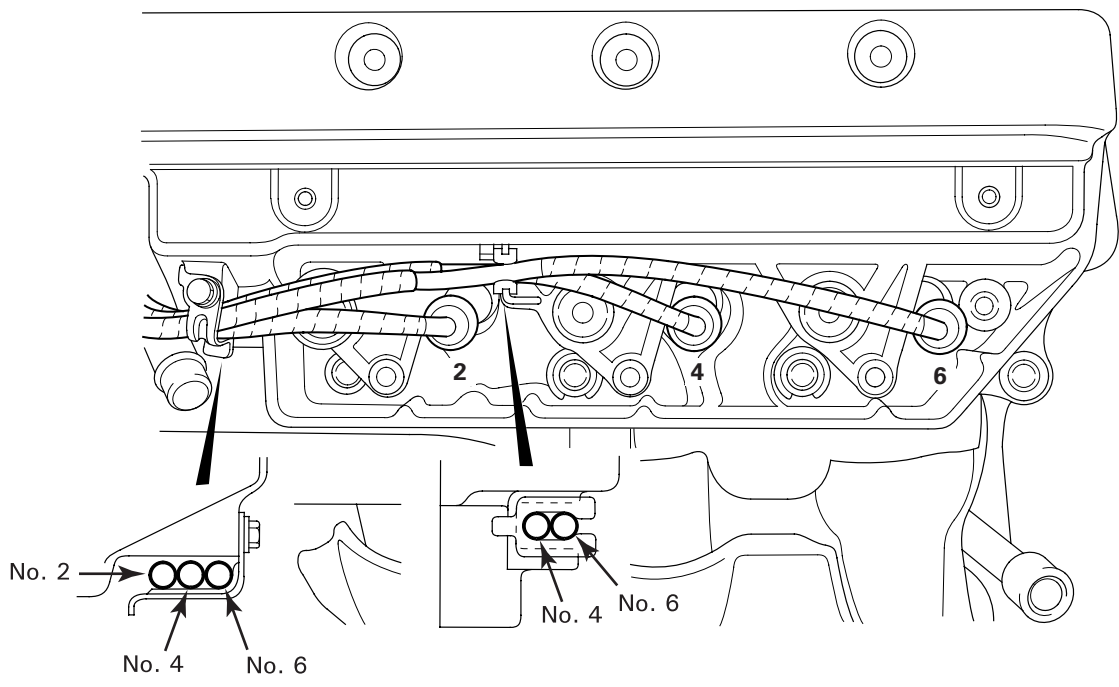
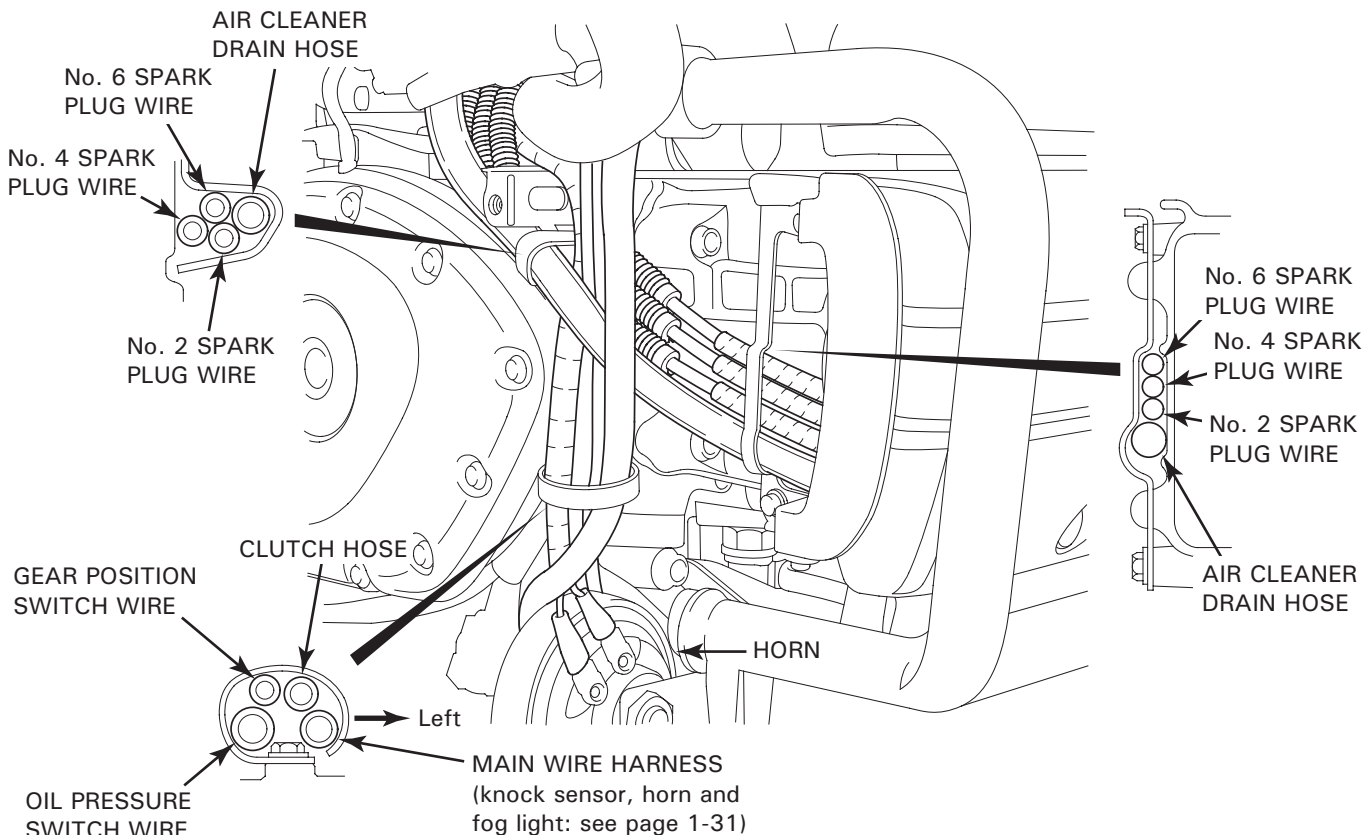

# GENERAL INFORMATION

\*: ABS (Anti-lock Brake System) model

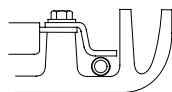
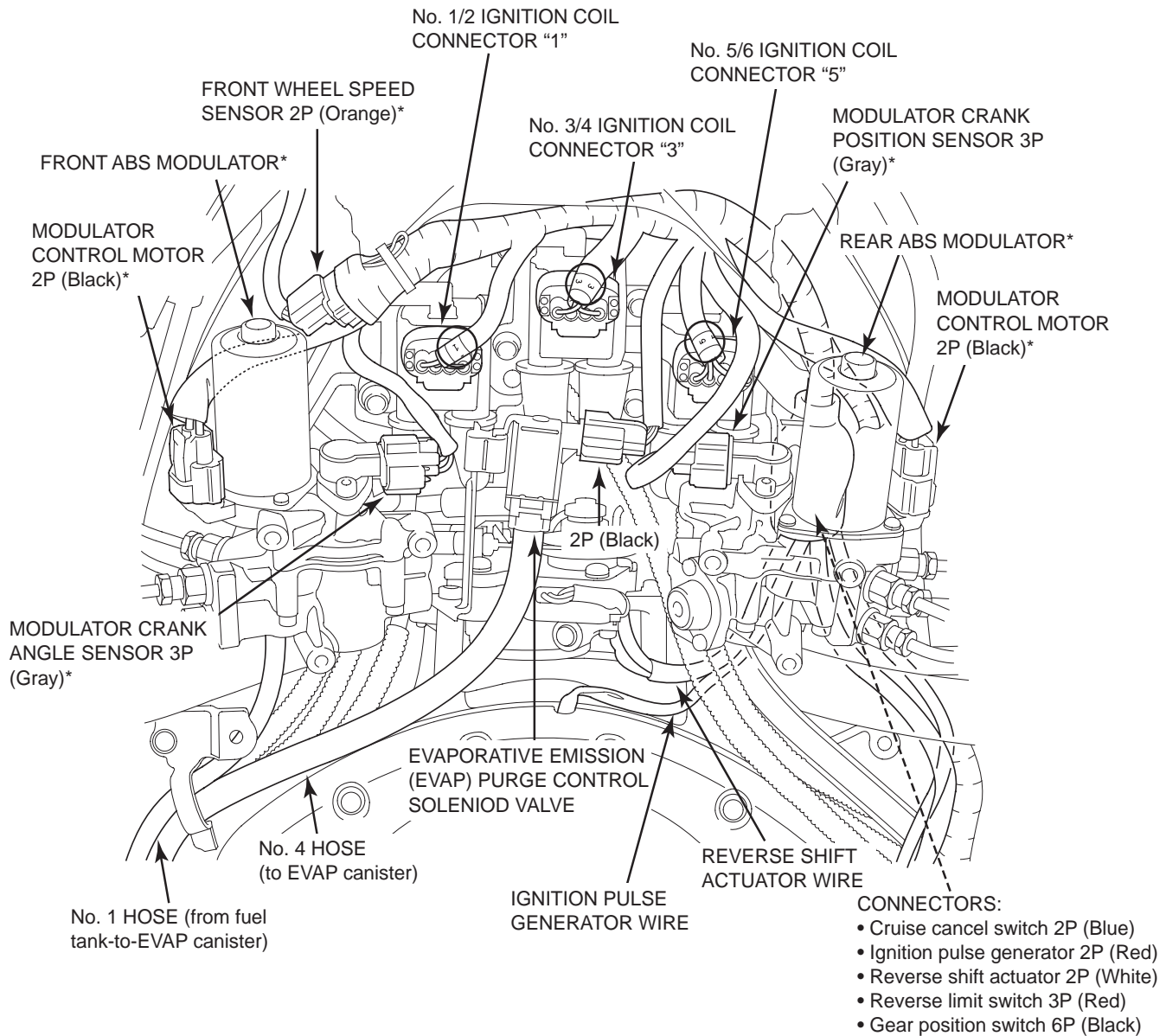

Reverse side of the front crankcase cover:

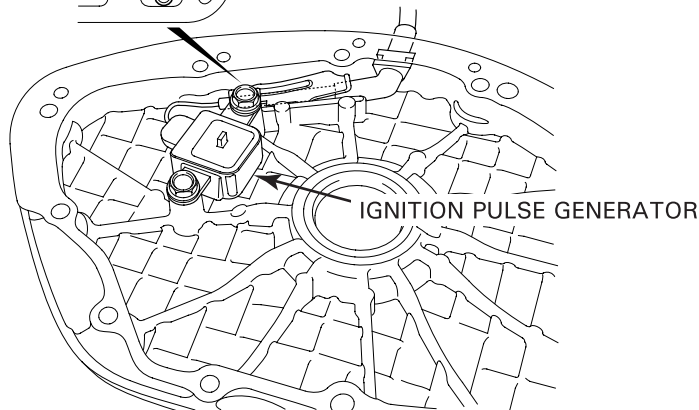

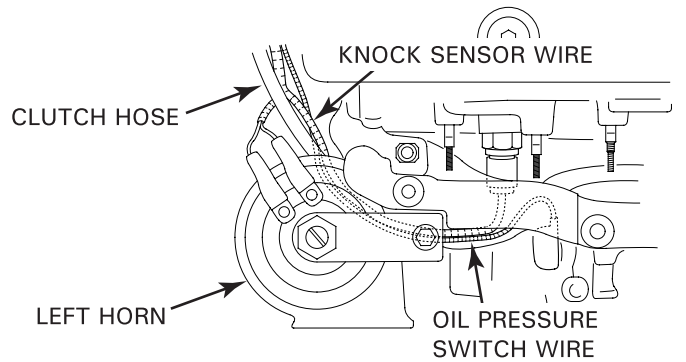
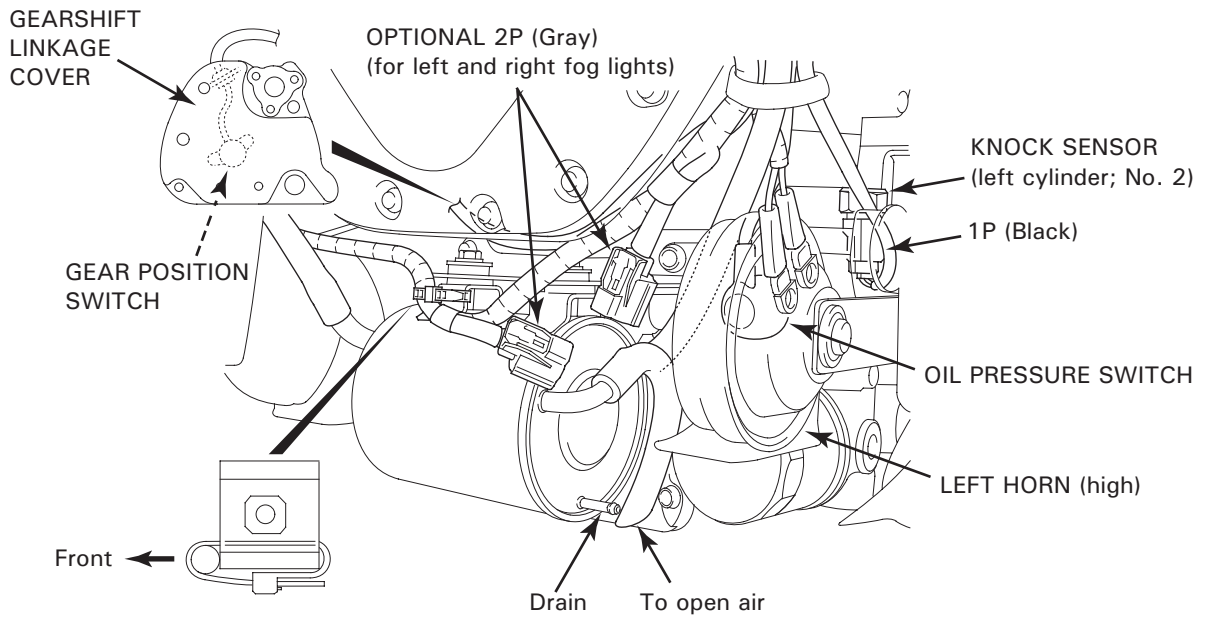
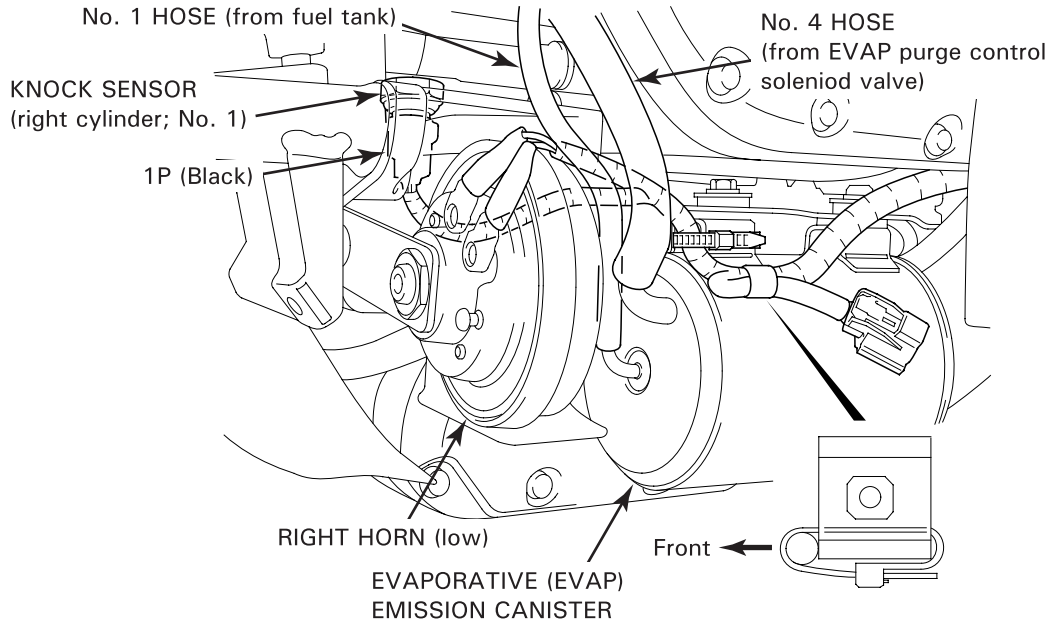



# GENERAL INFORMATION

Right side:

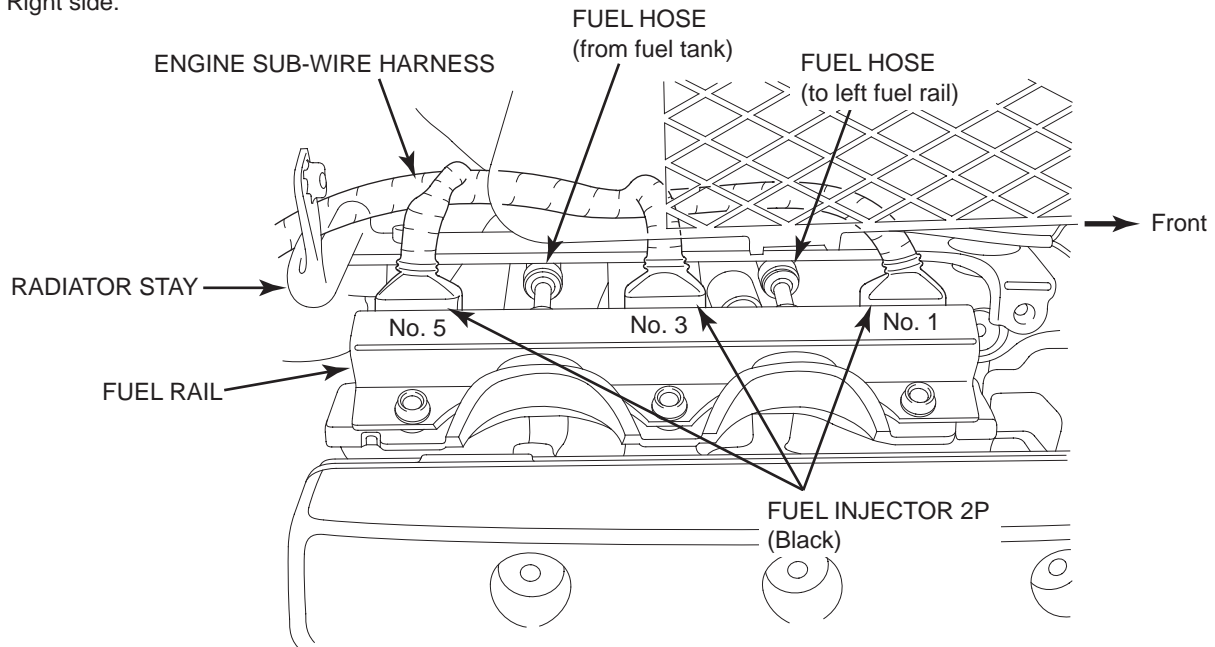

Left side:

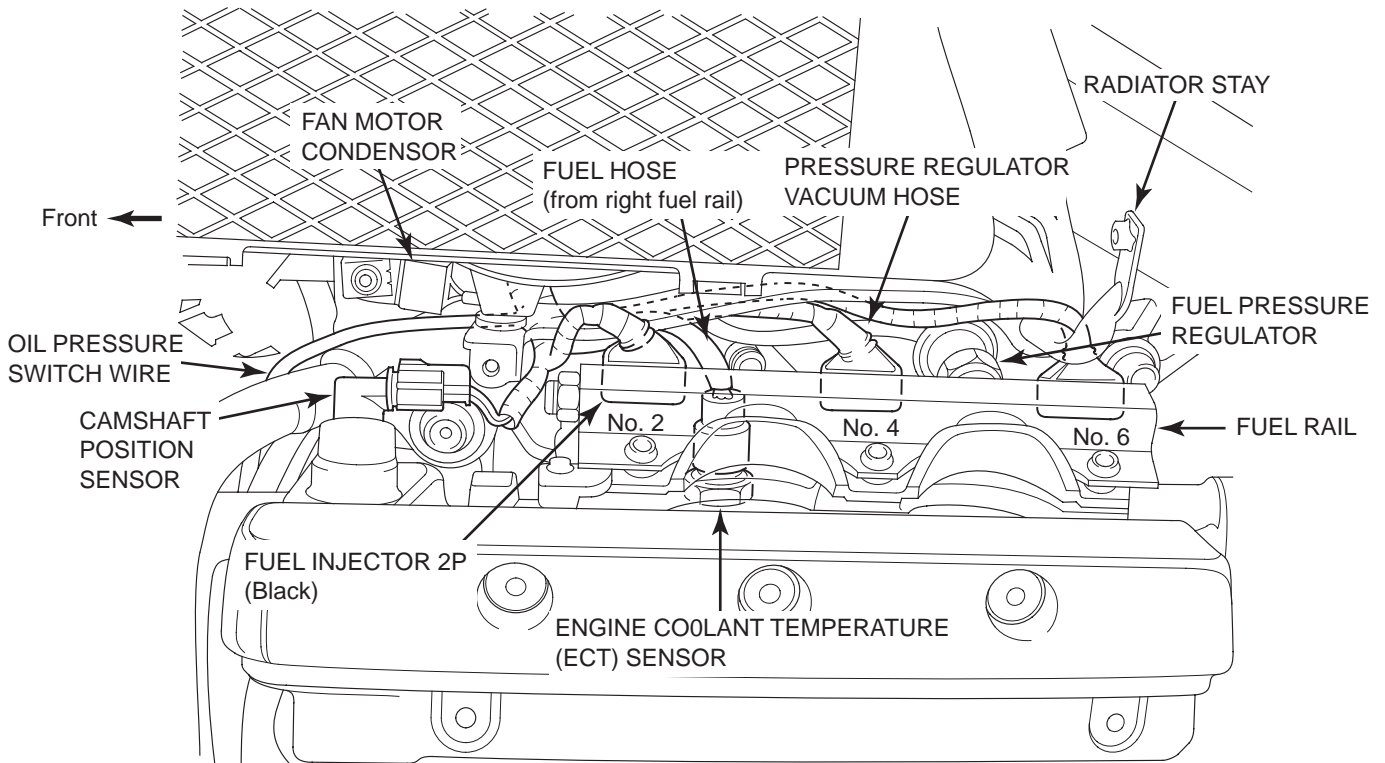

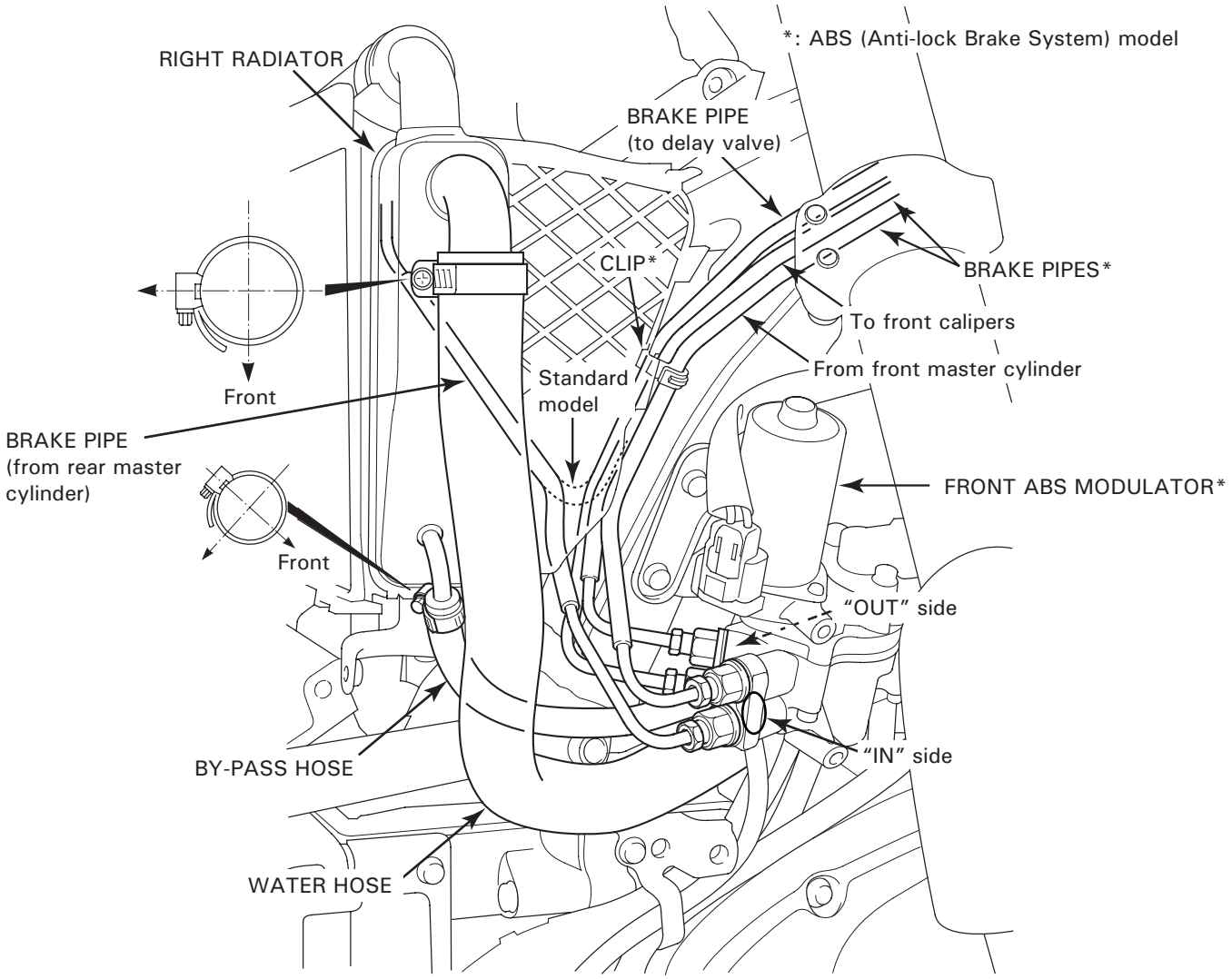

ABS model:

Brake pipe connection:

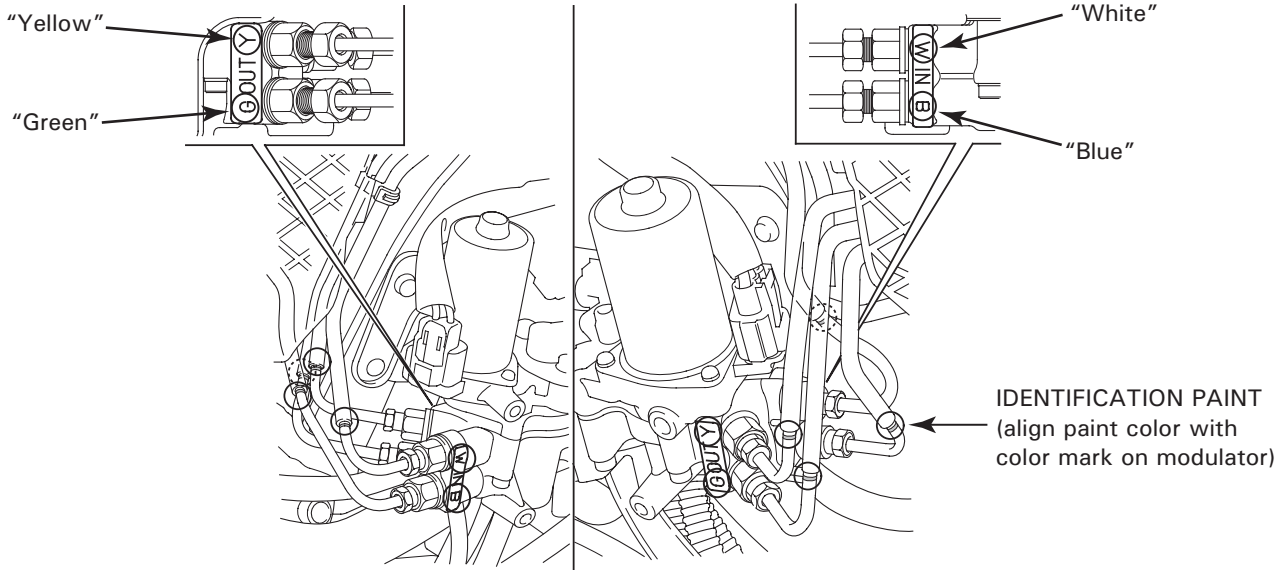



# GENERAL INFORMATION

\*: ABS (Anti-lock Brake System) model

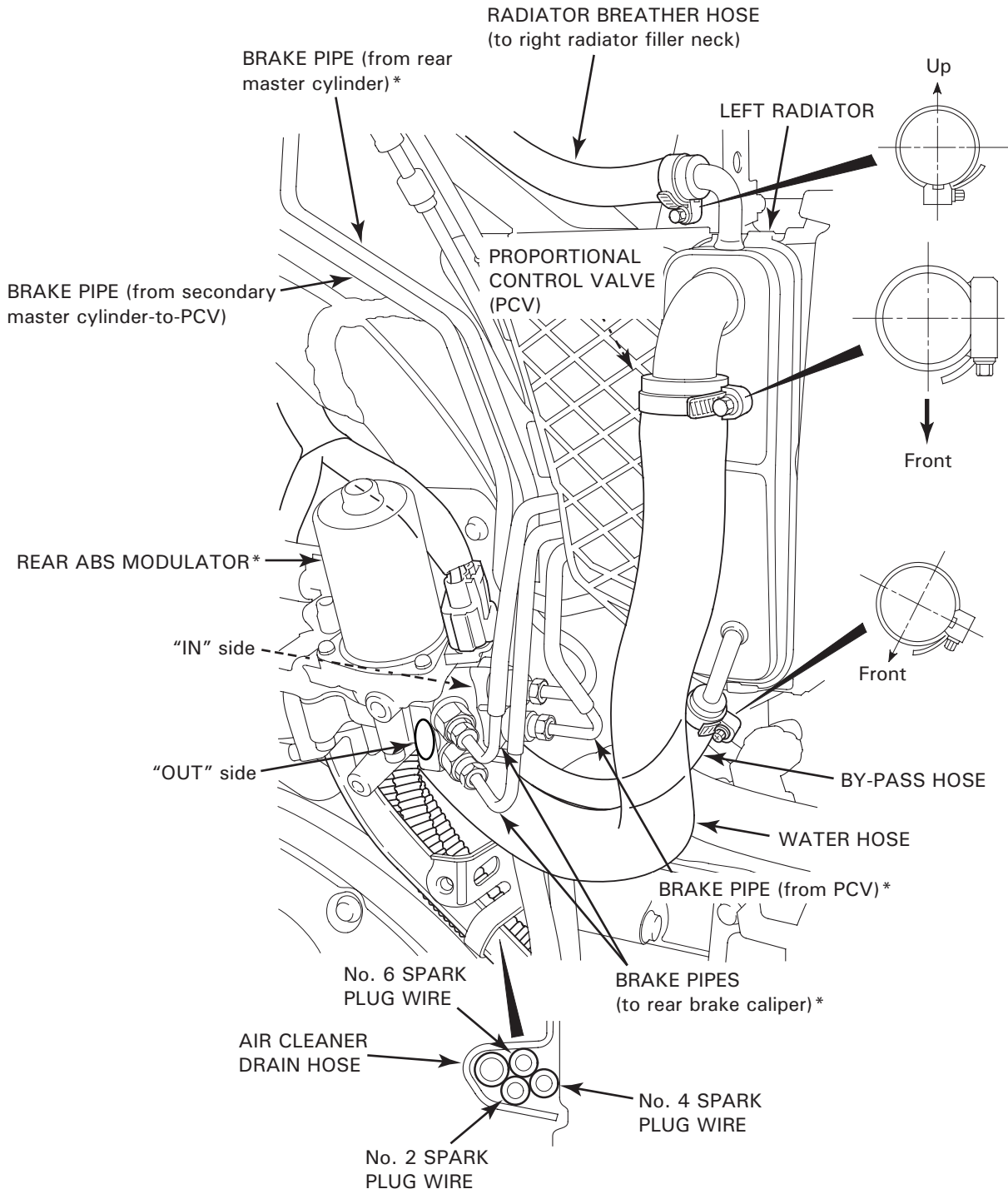

CONNECTORS:

- Vehicle speed sensor 3P (White)
- Right O<sub>2</sub> sensor 4P (White) (cylinders 1-3-5)
- Rear master cylinder brake light switch 3P (White)
- Rear master cylinder cruise cancel switch 2P (Red)
- Engine sub-wire harness 4P (Gray)

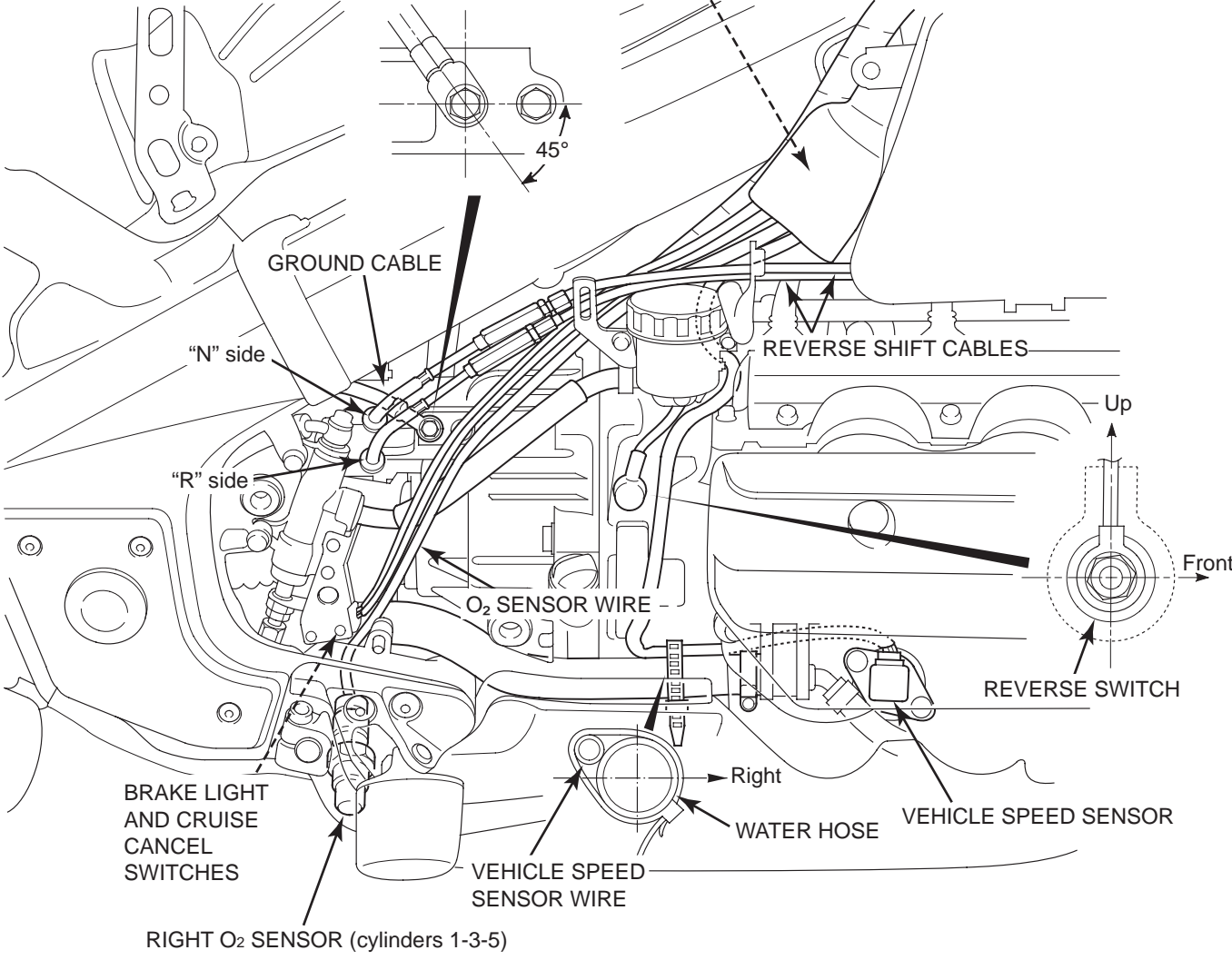

# GENERAL INFORMATION

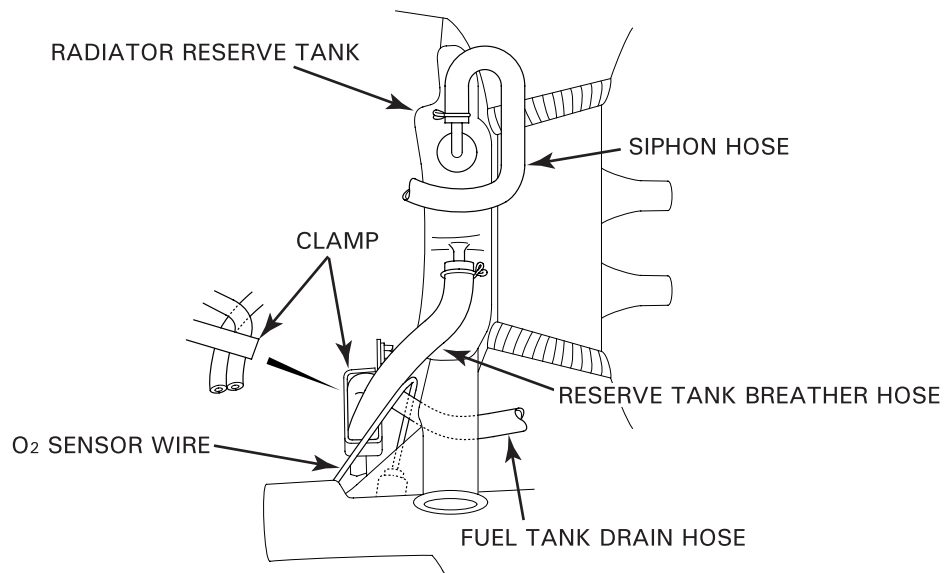
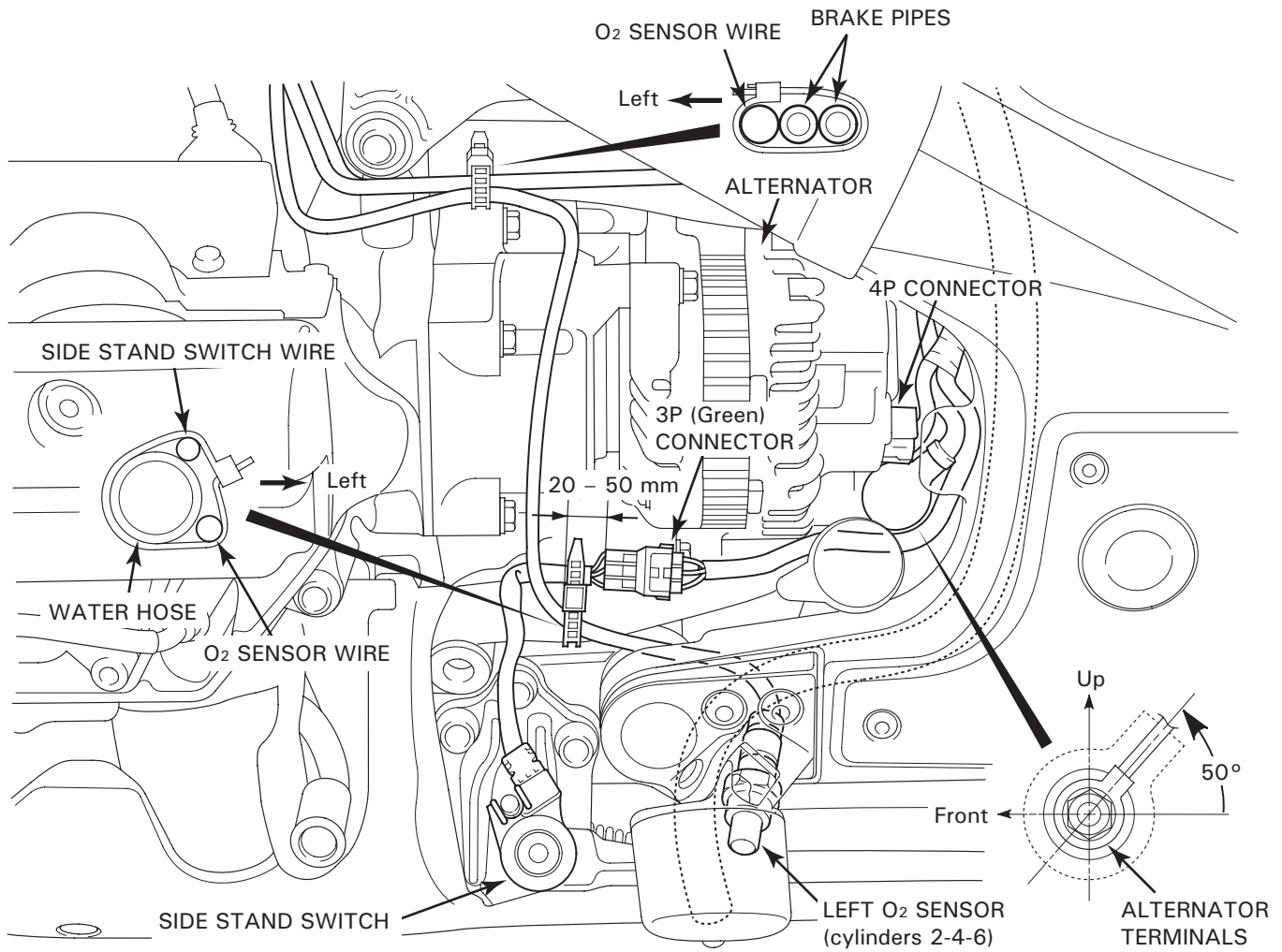

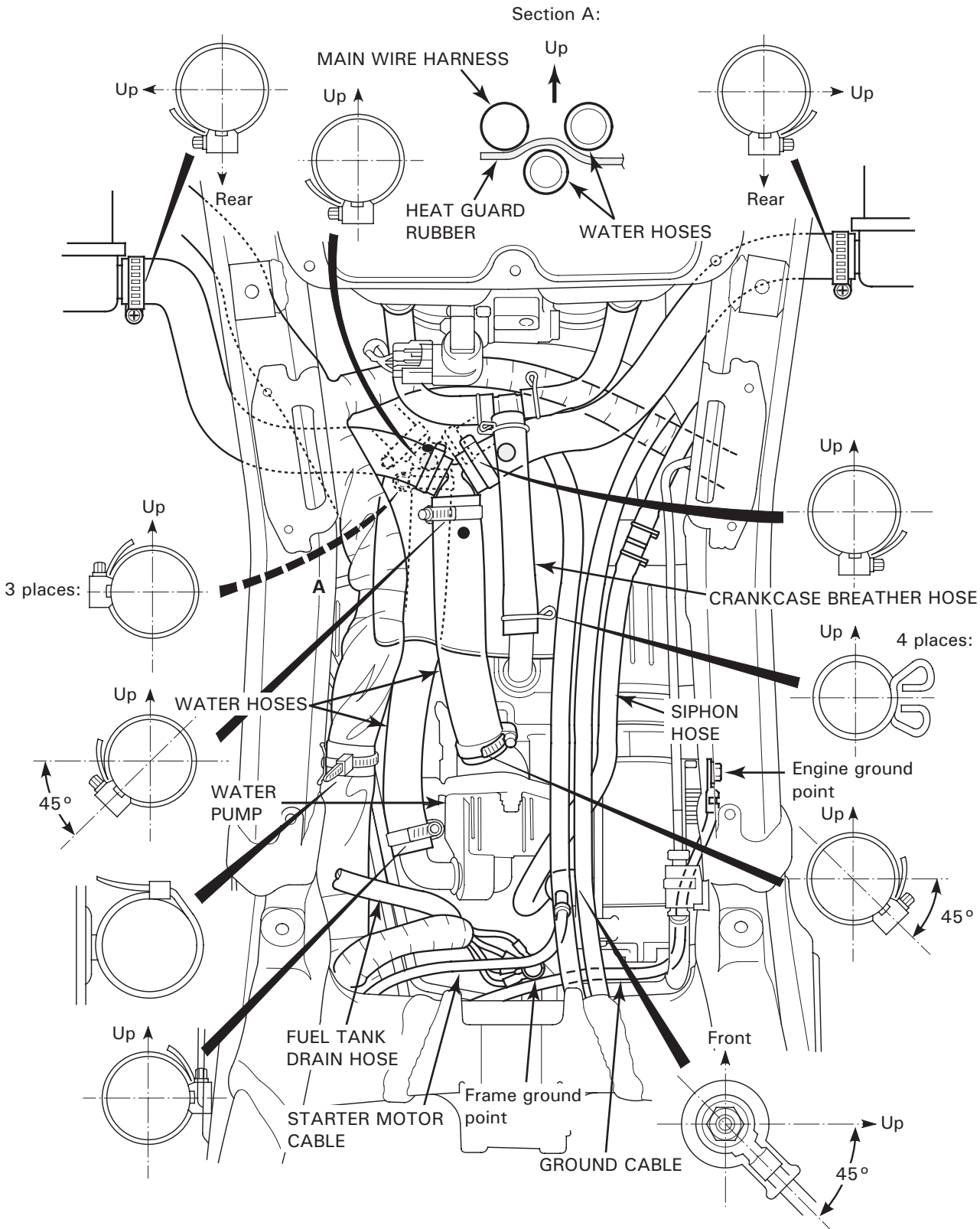

# GENERAL INFORMATION

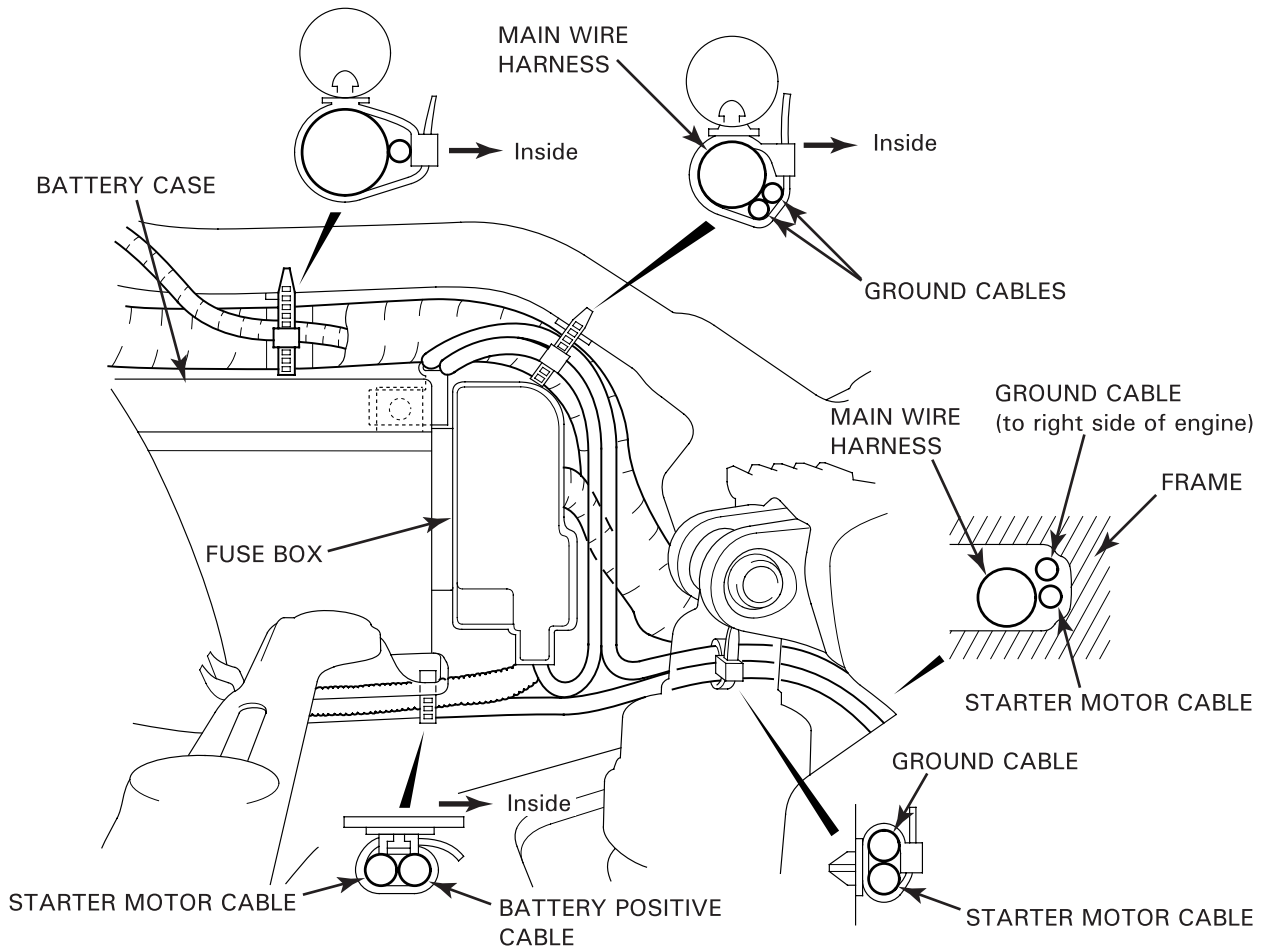
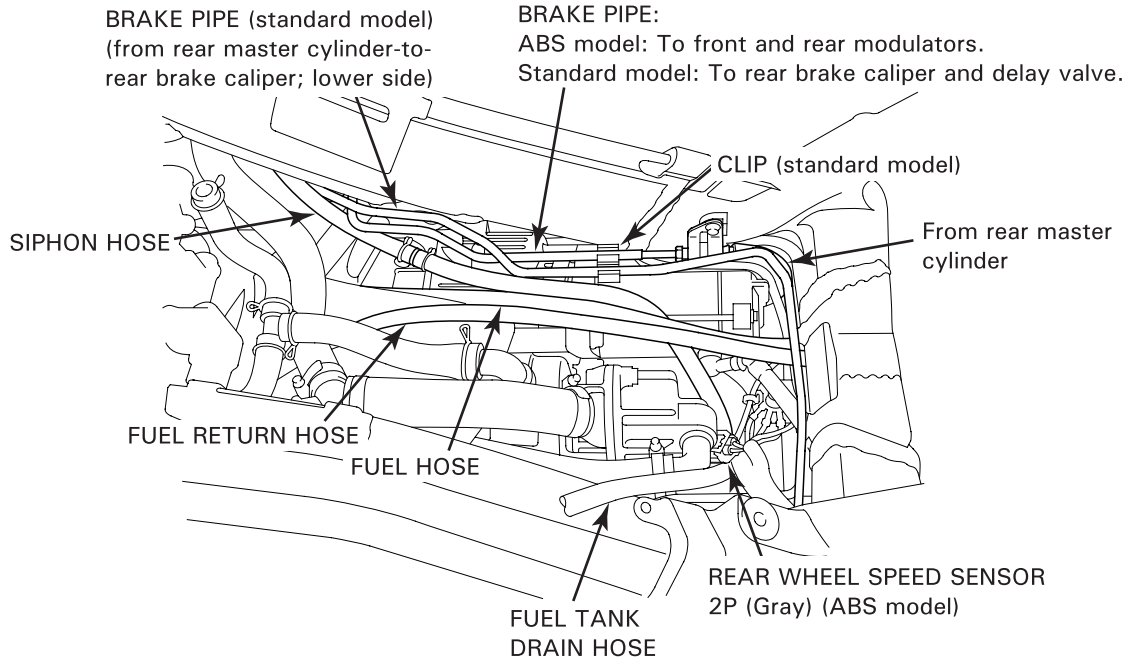

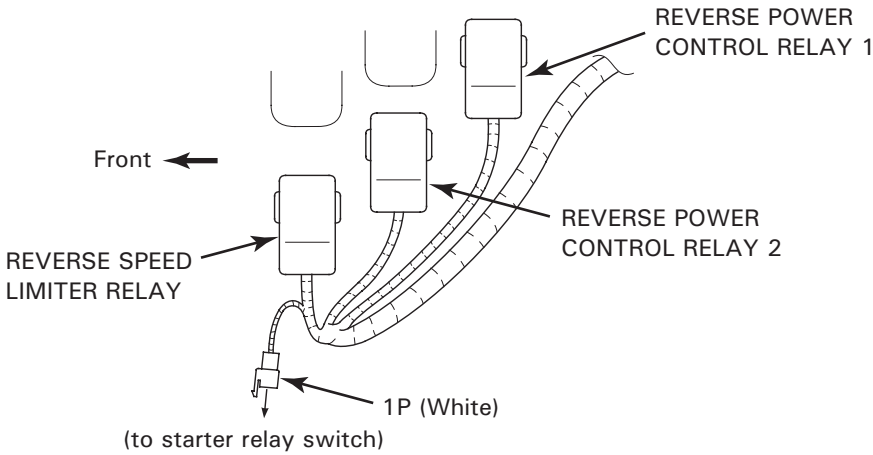
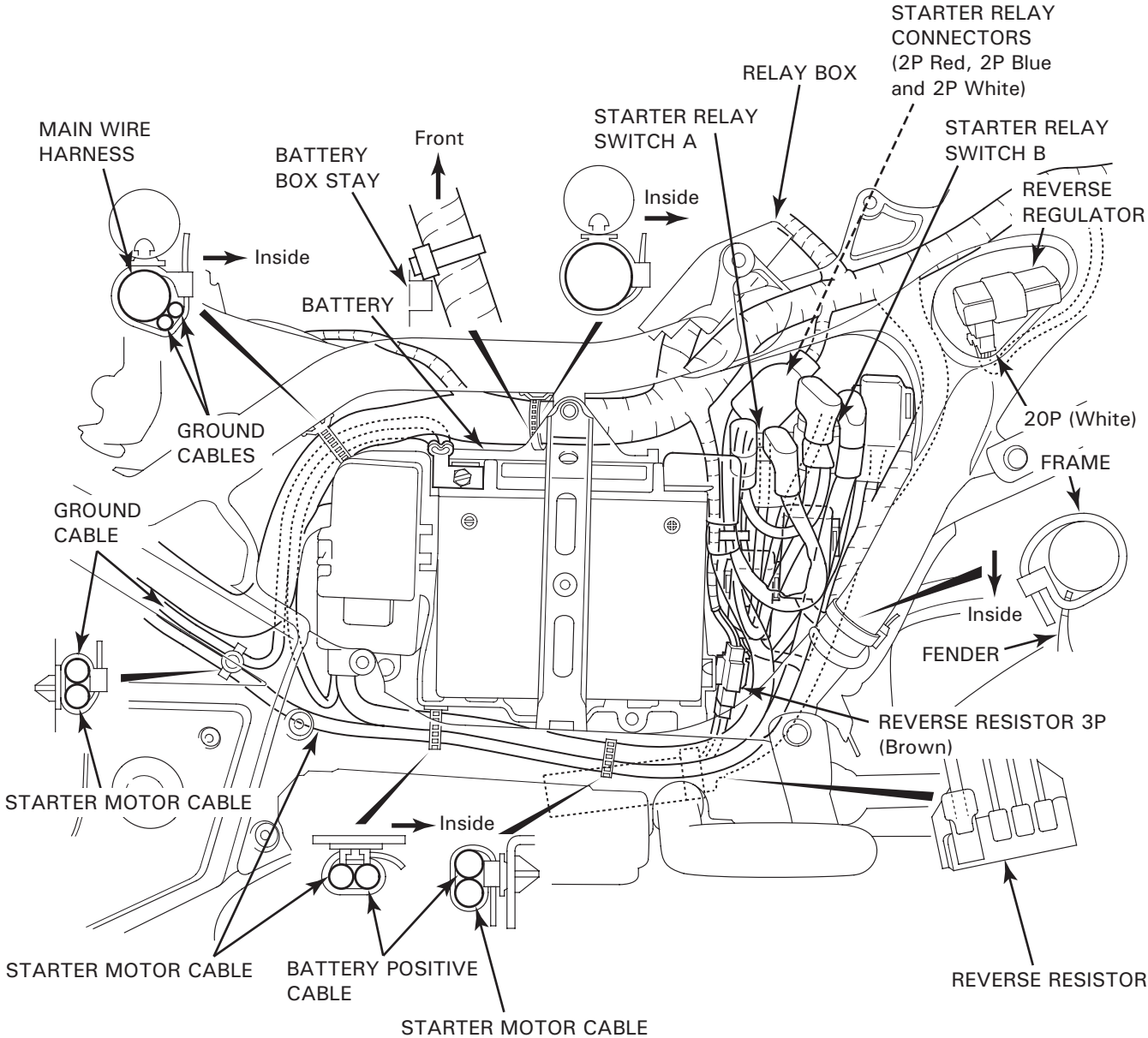



# GENERAL INFORMATION

'01, '02:

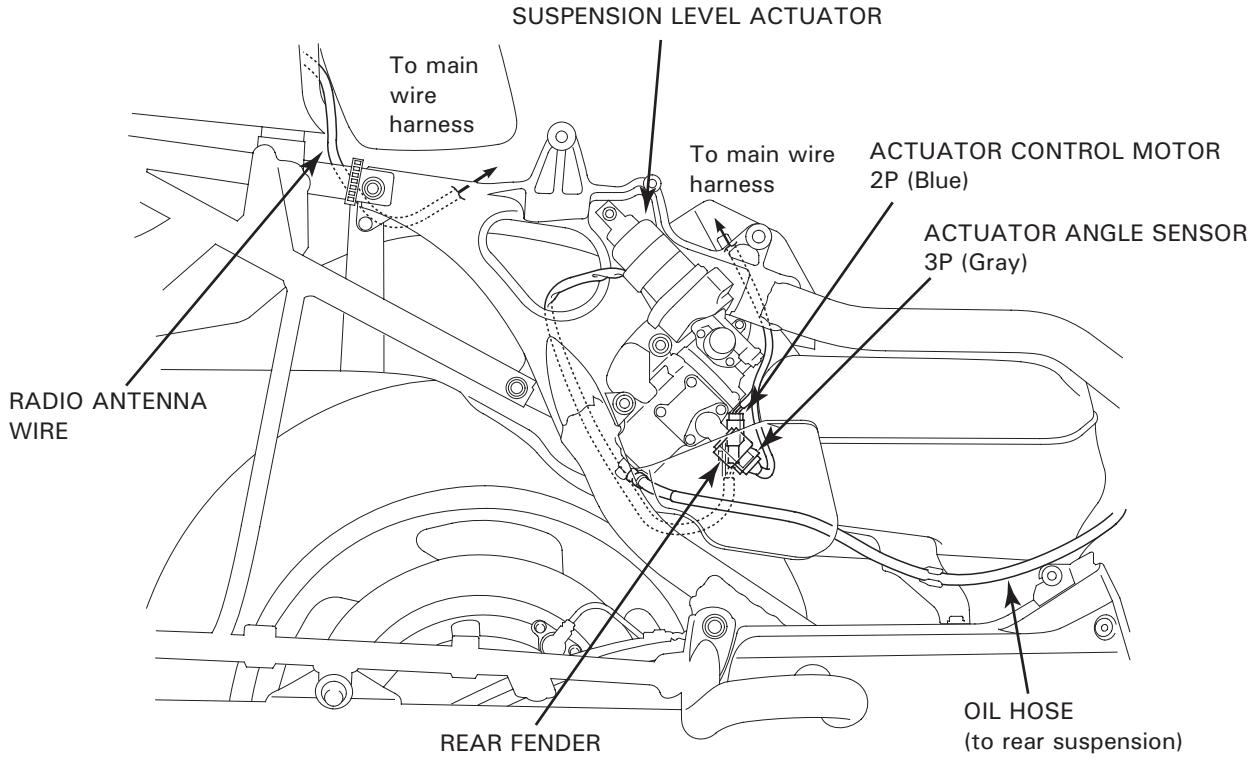

After '02:

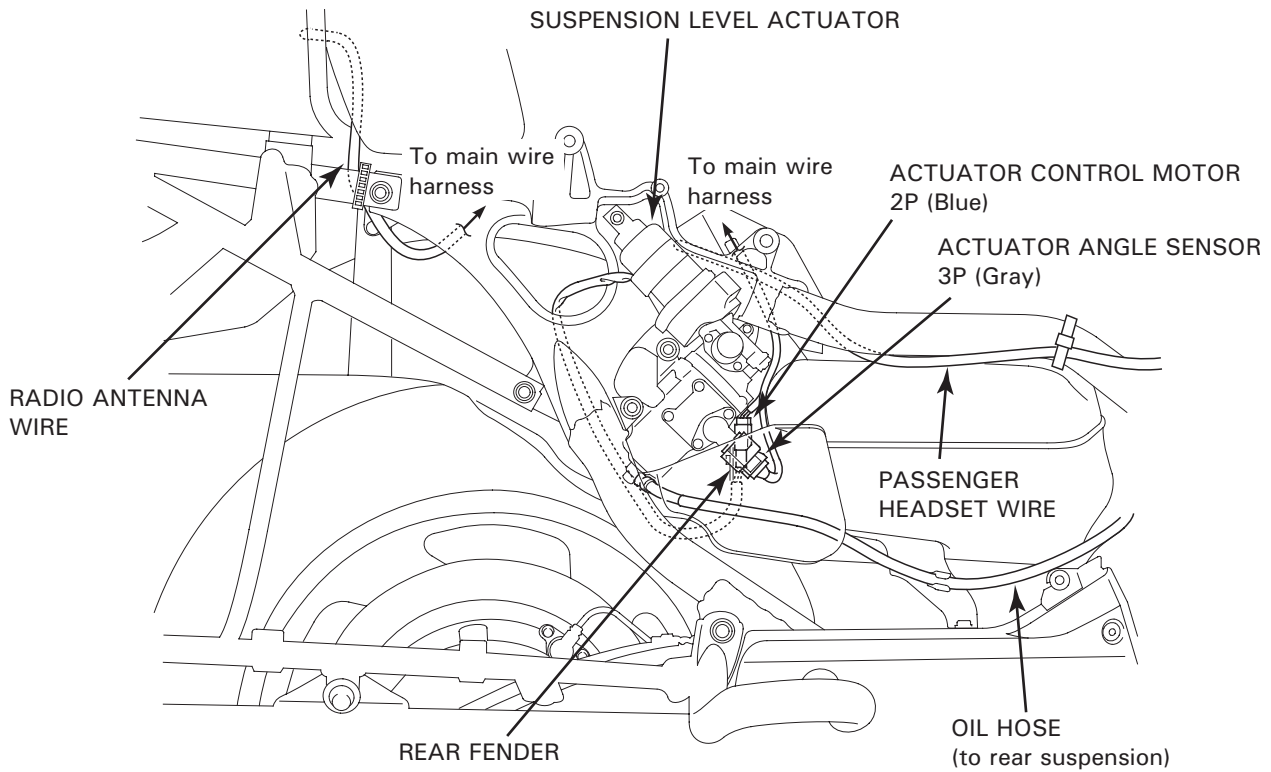

'01 - '03:

\*: ABS (Anti-lock Brake System) model

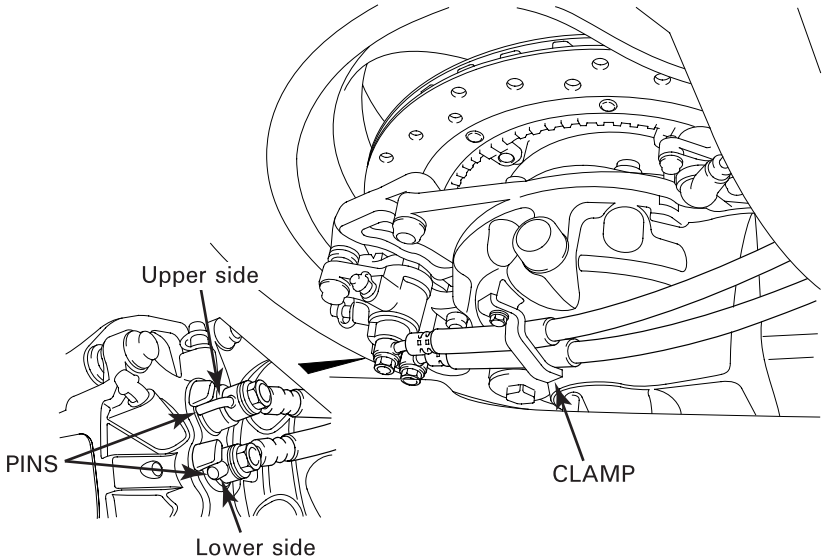
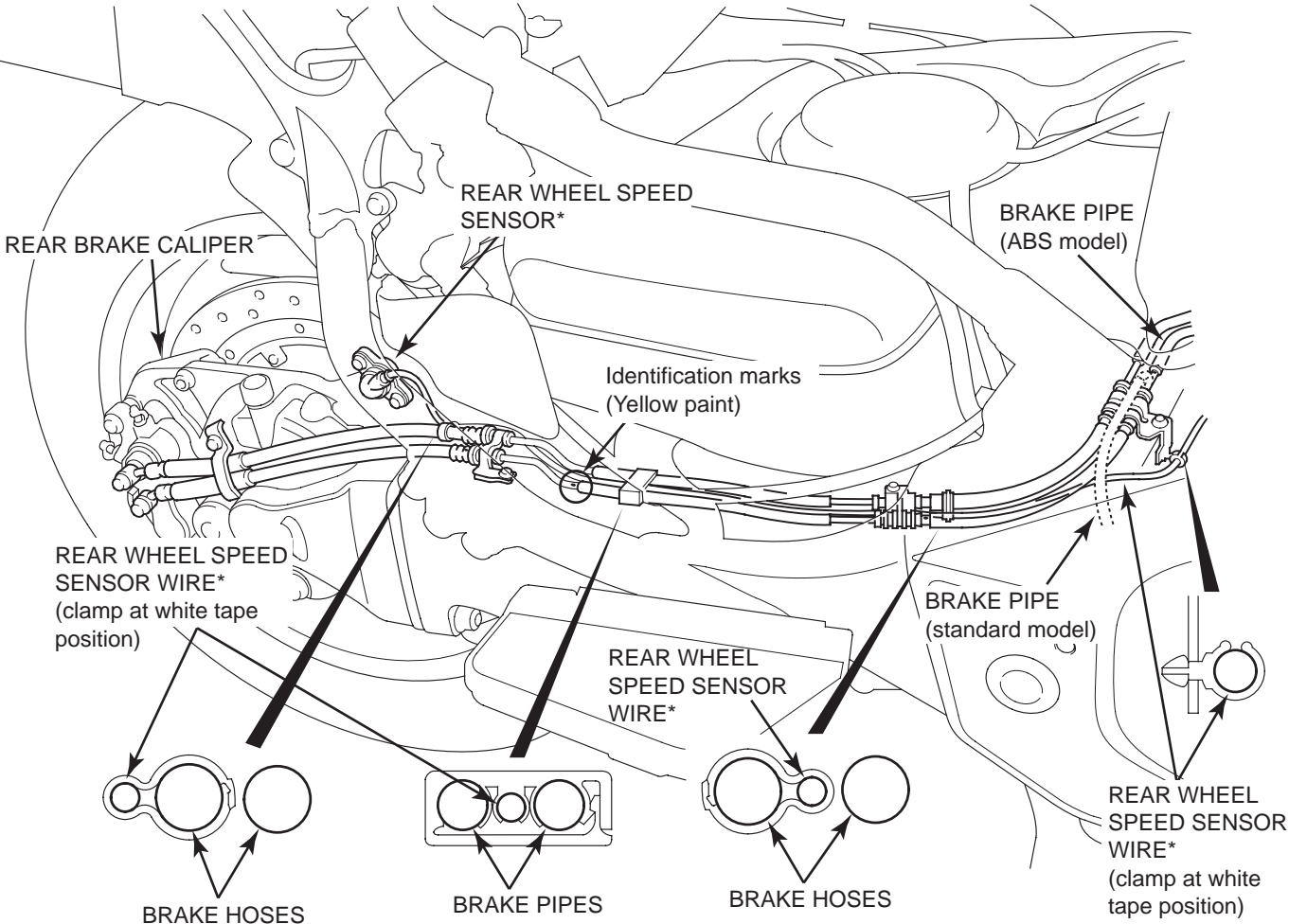



# GENERAL INFORMATION

After '03:

\* : ABS (Anti-lock Brake System) model

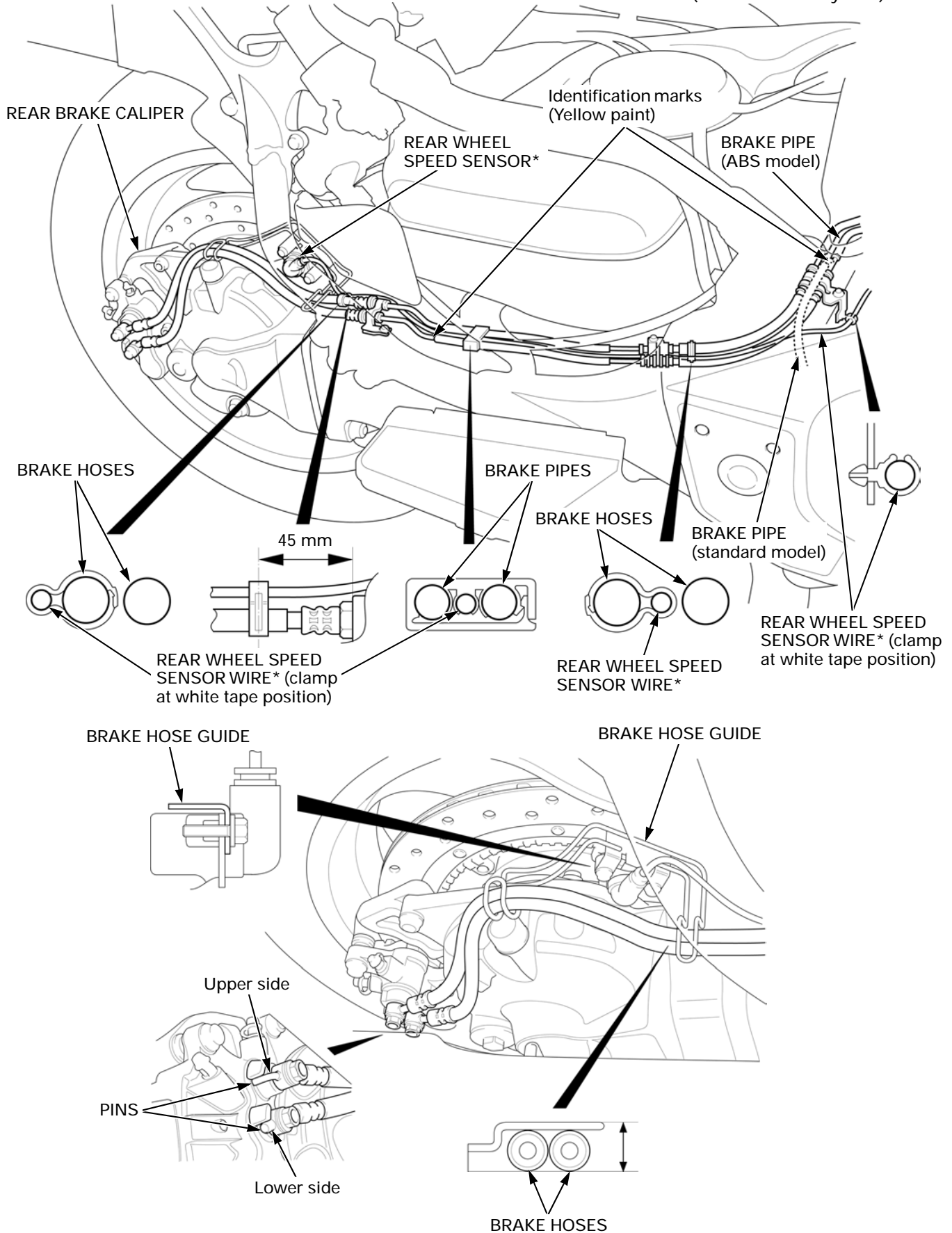

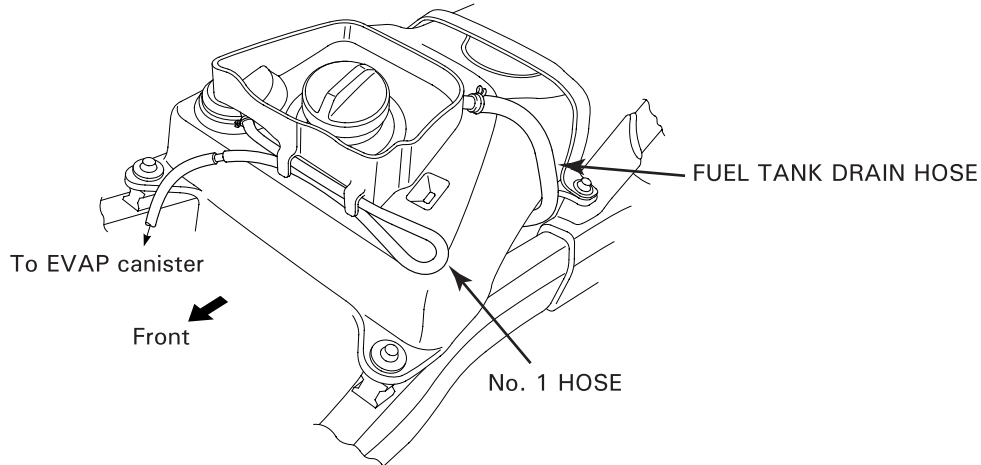

'01, '02:

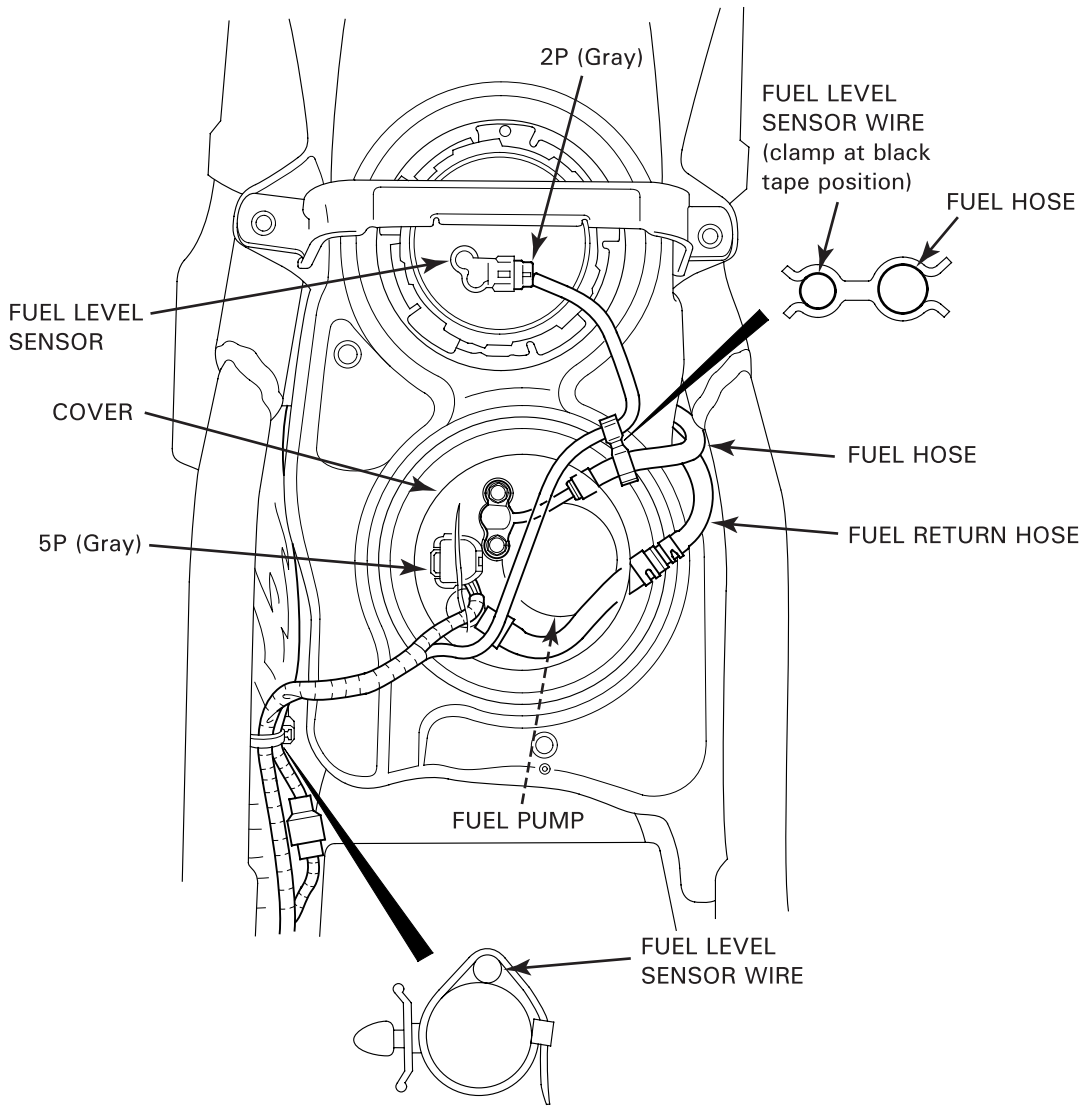

# GENERAL INFORMATION

After '02:

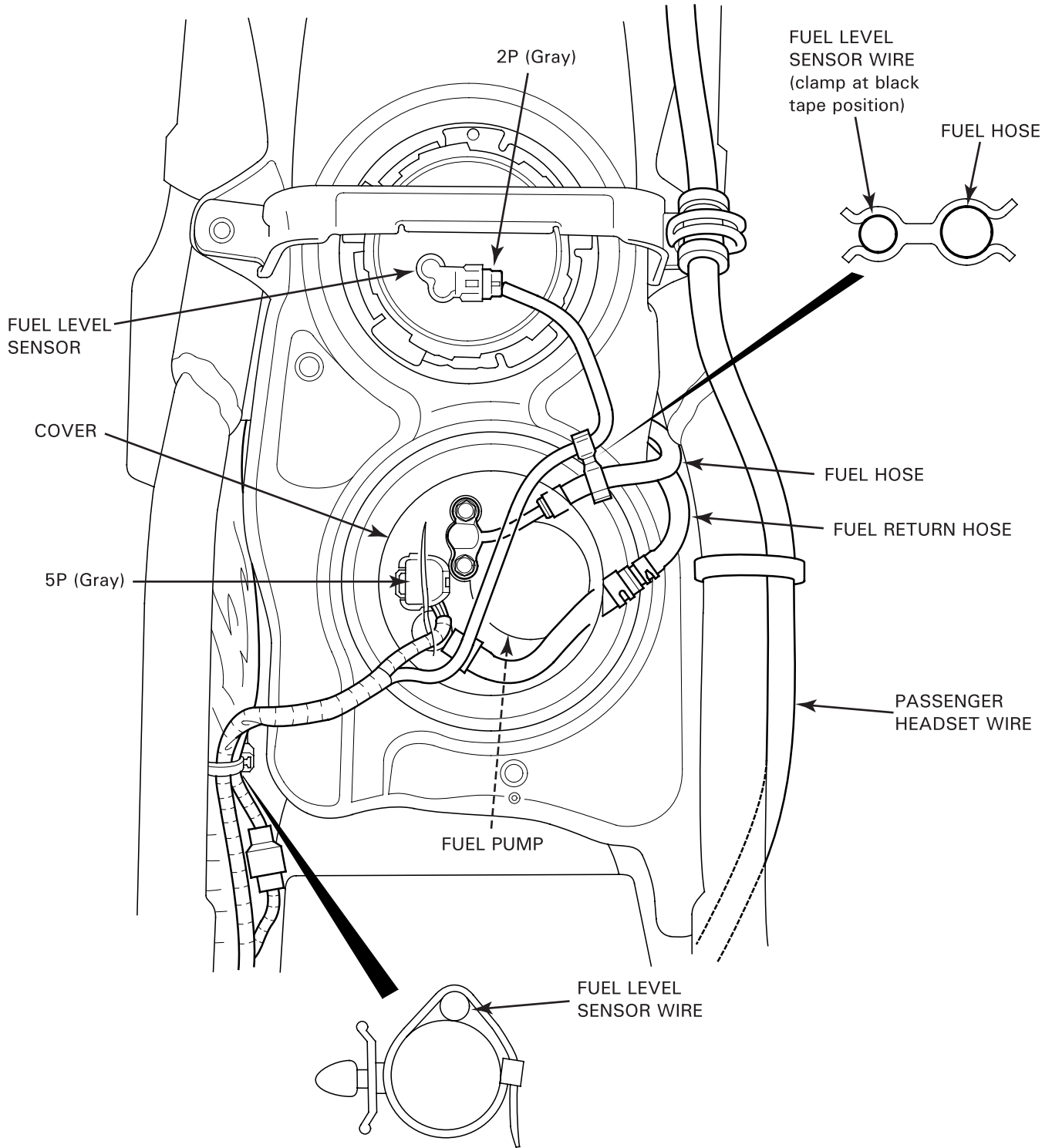

'01:

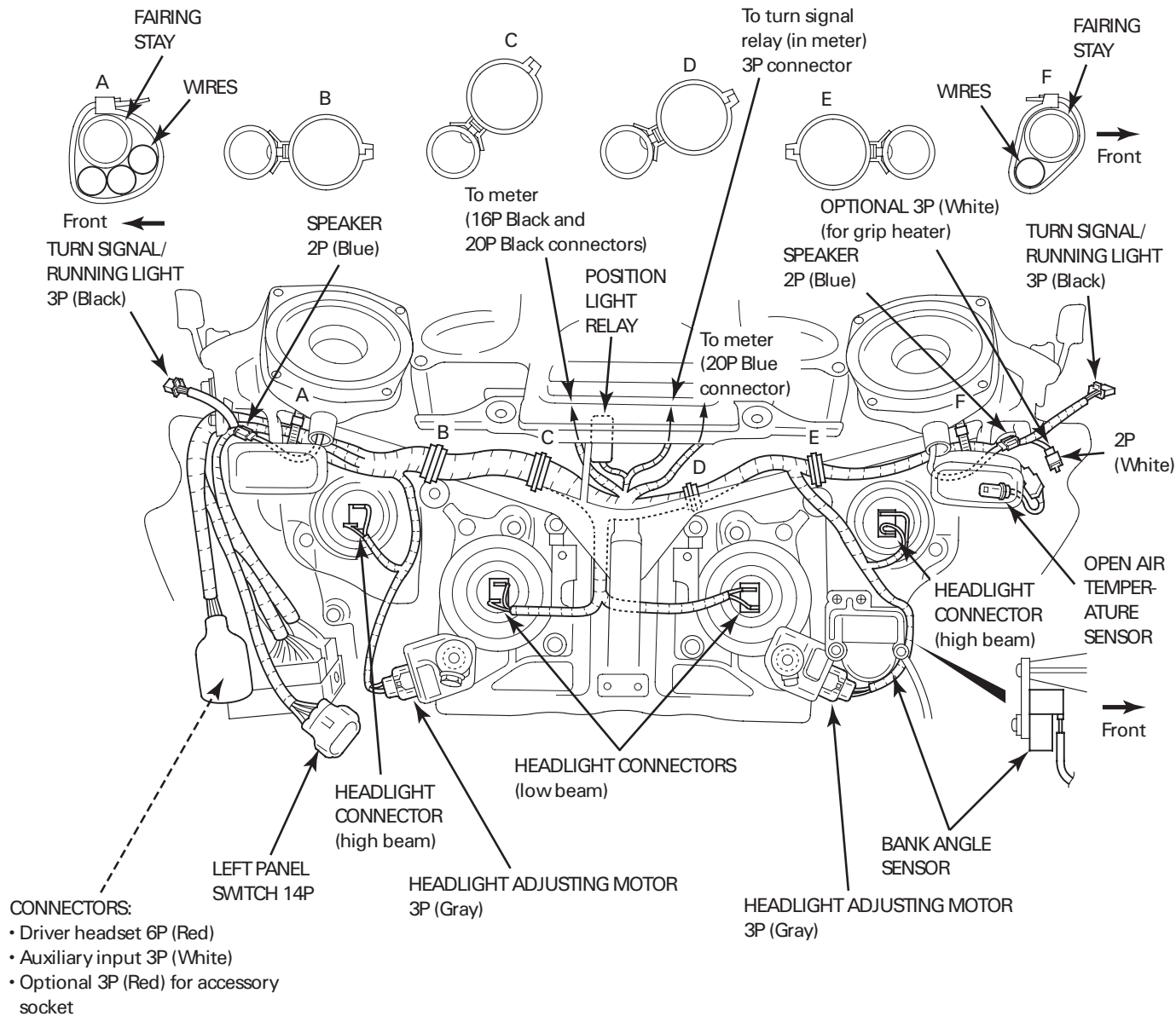

# GENERAL INFORMATION

After '01:

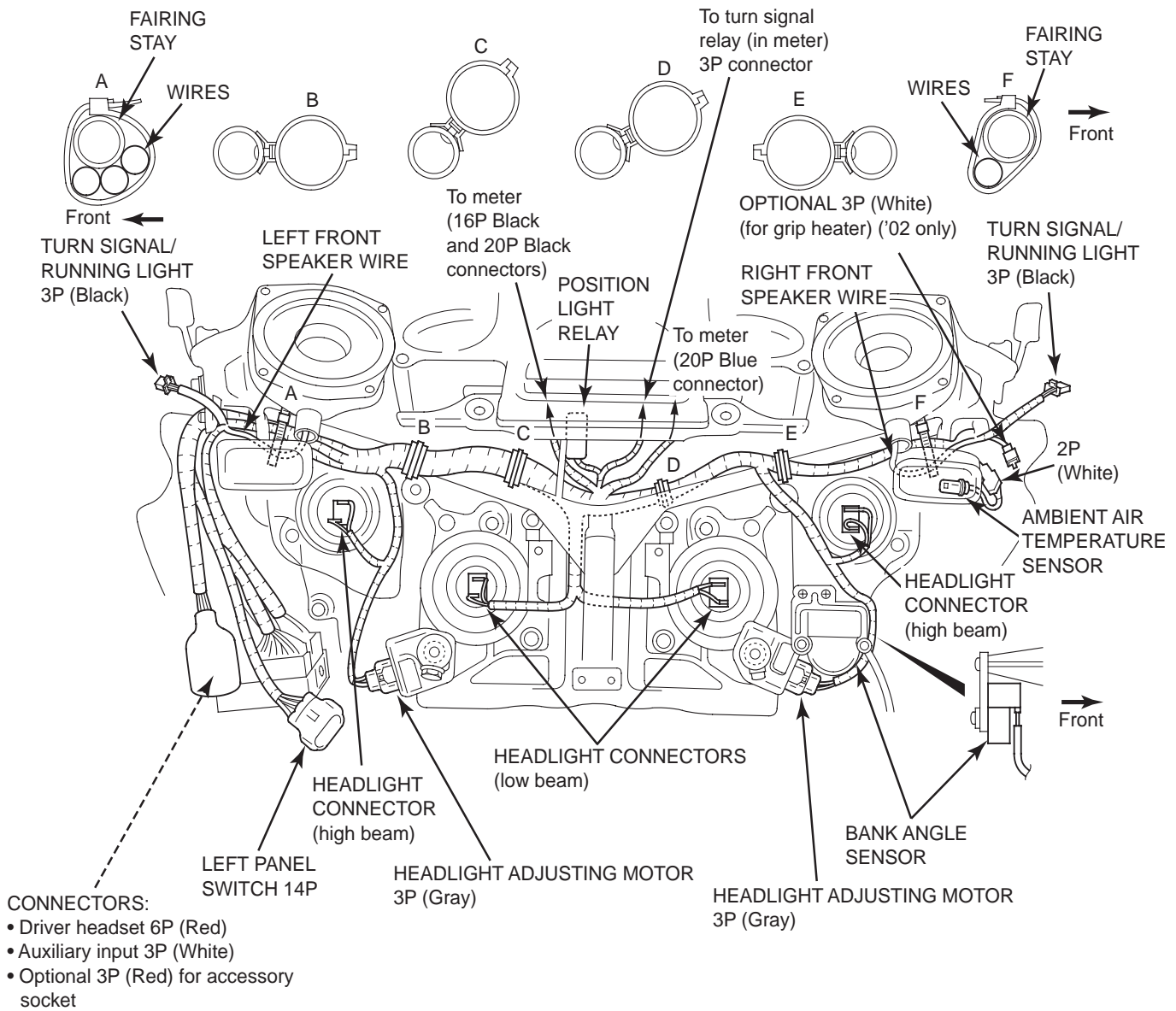

'01:

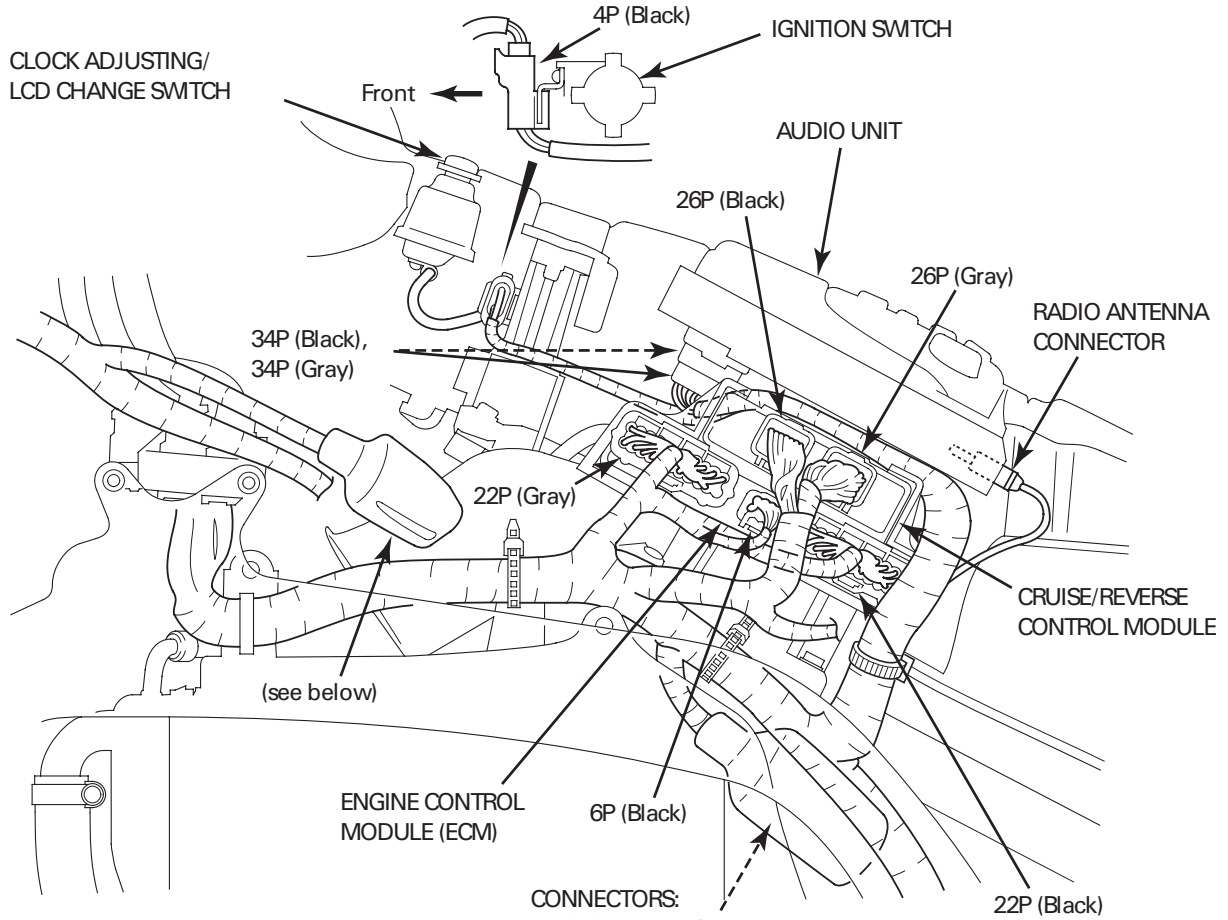

**CONNECTORS:**

- Left fan motor 2P (Black)
- Left O<sub>2</sub> sensor 4P (Black) (cylinders 2-4-6)
- Engine subwire harness 4P (Gray)
- Optional 4P (Black) for fog light switch

**CONNECTORS:**

- Driver headset 6P (Red)
- Auxiliary input 3P (White)
- Optional 3P (Red) for accessory socket

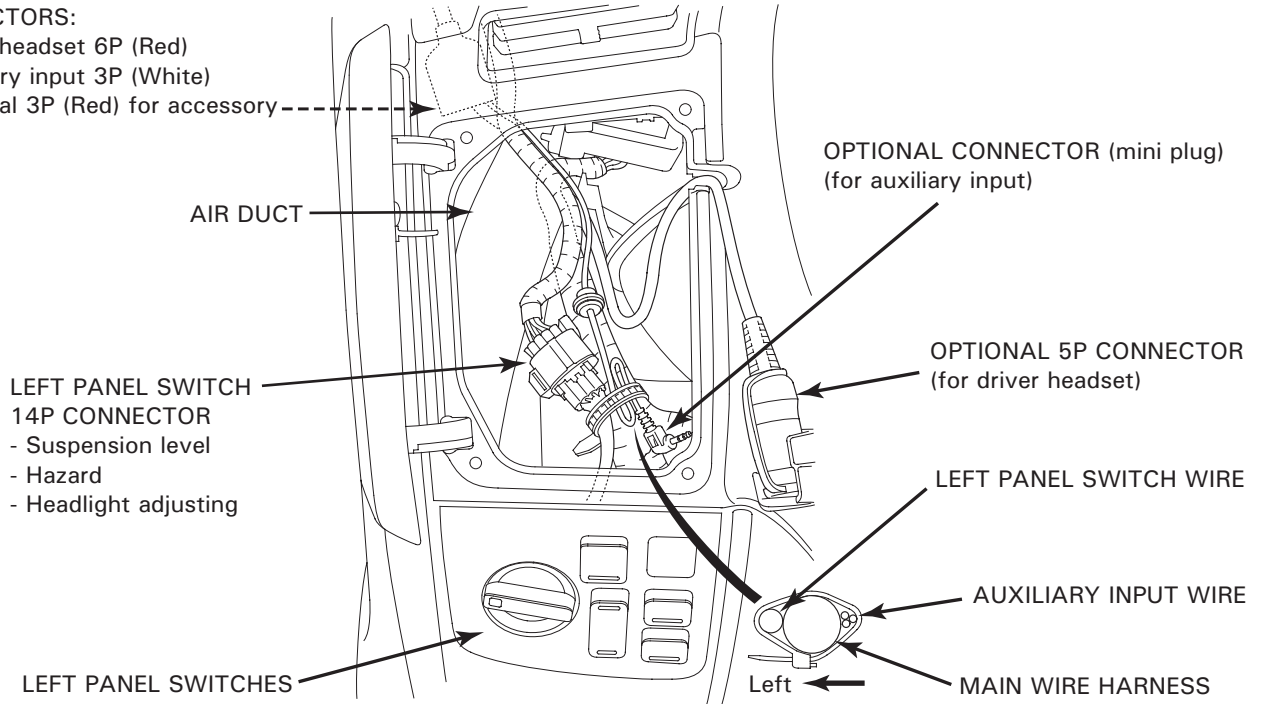

# GENERAL INFORMATION

'02:

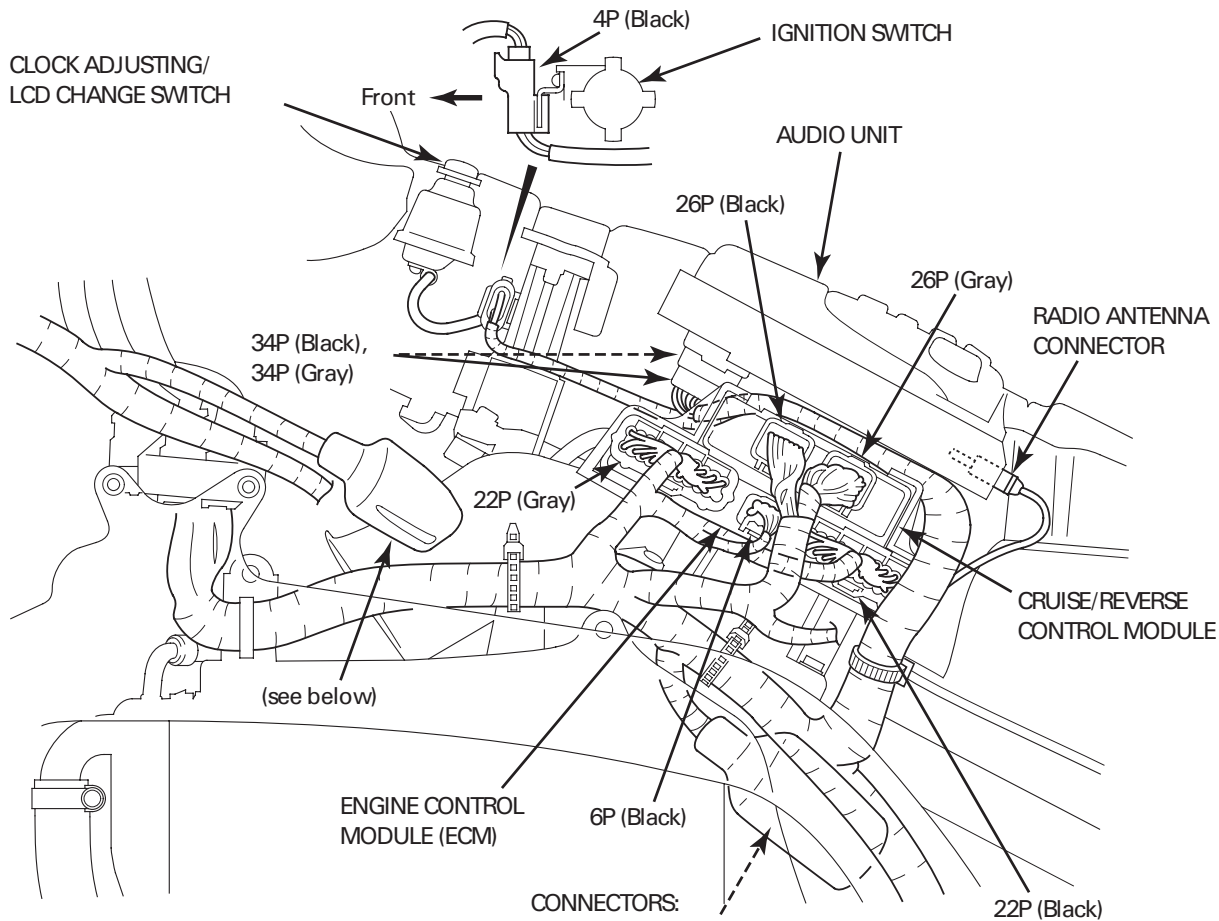

**CONNECTORS:**

- Left fan motor 2P (Black)
- Left O<sub>2</sub> sensor 4P (Black) (cylinders 2-4-6)
- Engine subwire harness 4P (Gray)
- Optional 4P (Black) for fog light switch

**CONNECTORS:**

- Driver headset 6P (Red)
- Auxiliary input 3P (White)
- Optional 3P (Red) for accessory socket

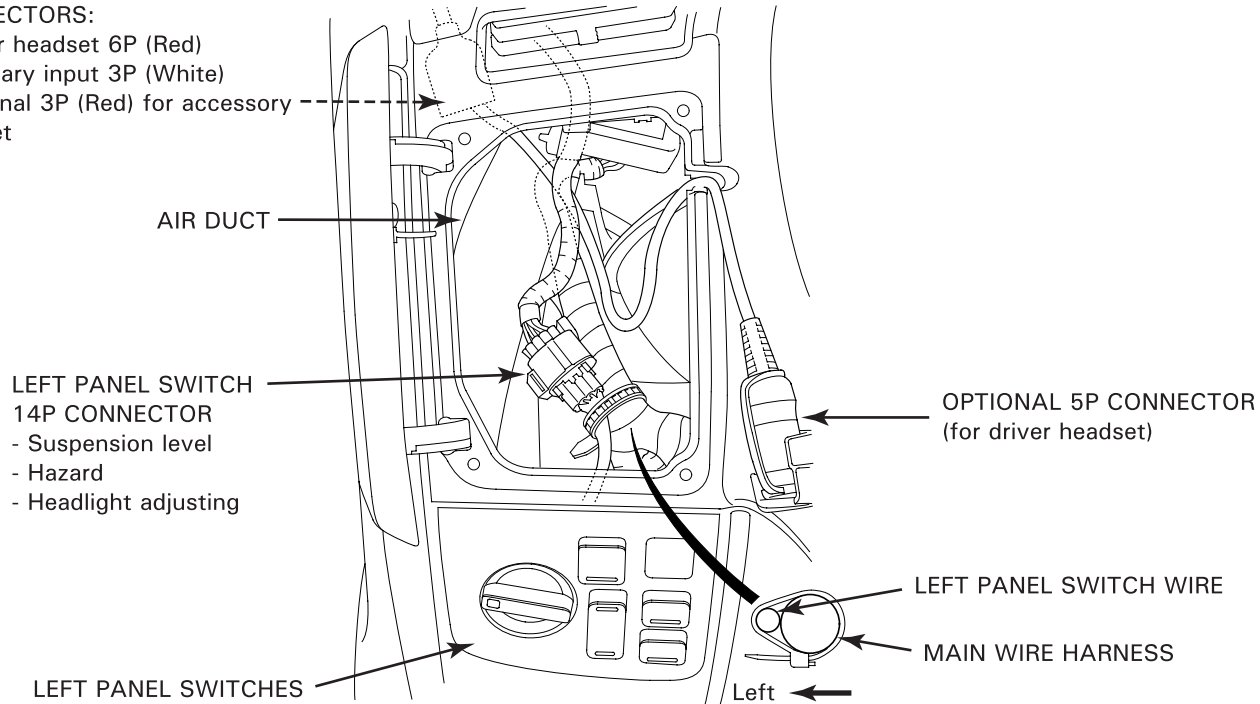



**After '02:**

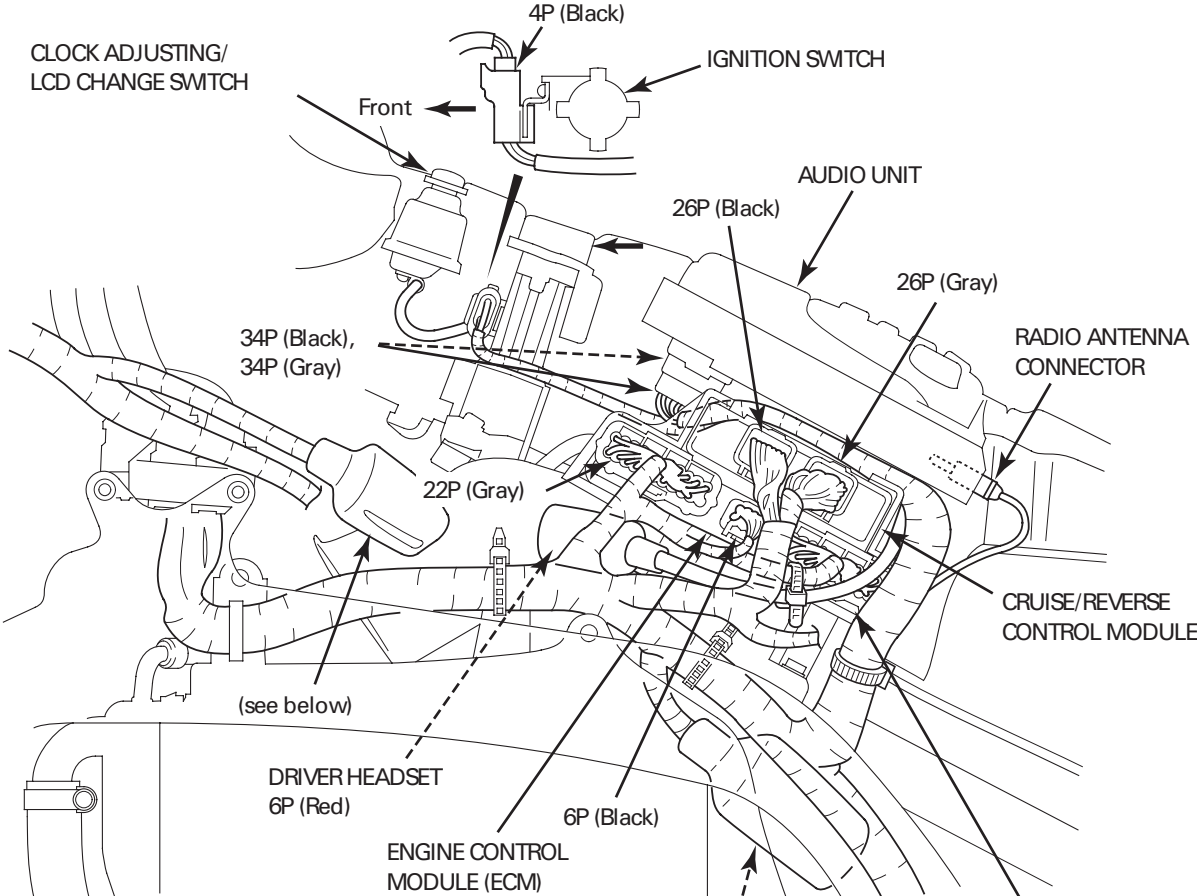

- CONNECTORS:**
- Left fan motor 2P (Black)
  - Left O<sub>2</sub> sensor 4P (Black) (cylinders 2-4-6)
  - Engine subwire harness 4P (Gray)
  - Optional 4P (Black) for fog light switch
- 22P (Black)

- CONNECTORS:**
- Auxiliary input 3P (White)
  - Optional 3P (Red) for accessory socket

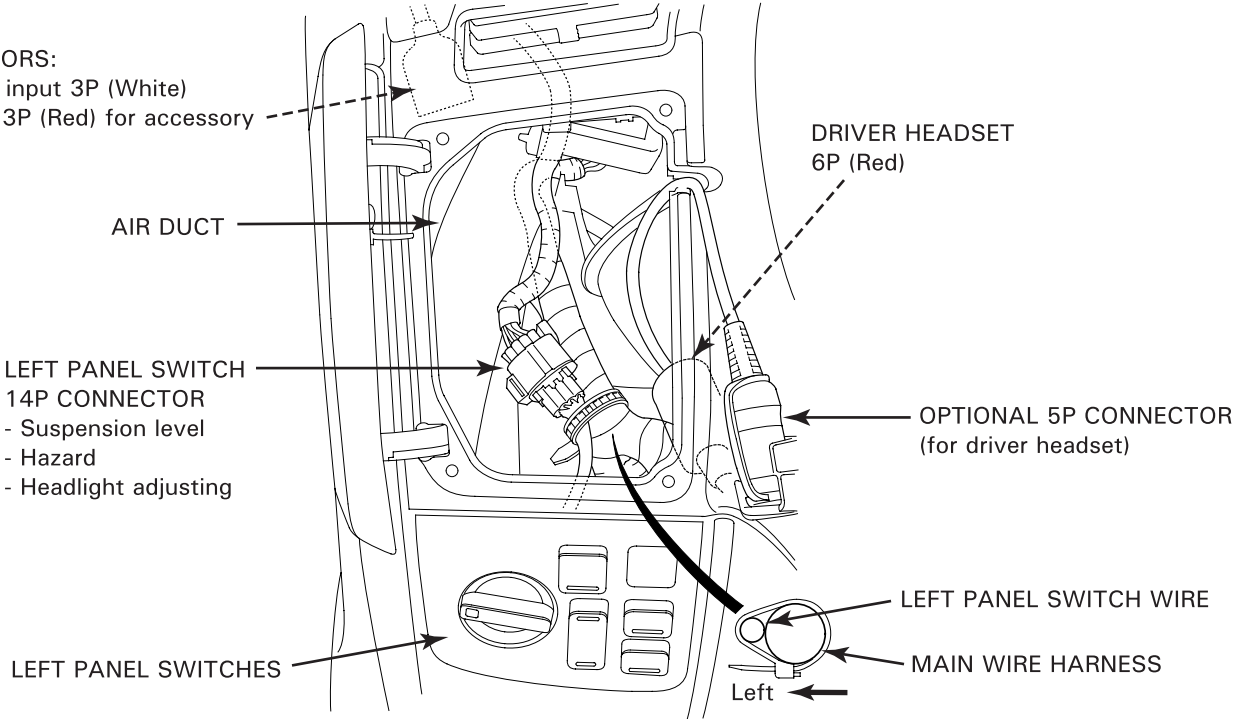



# GENERAL INFORMATION

'01, '02:

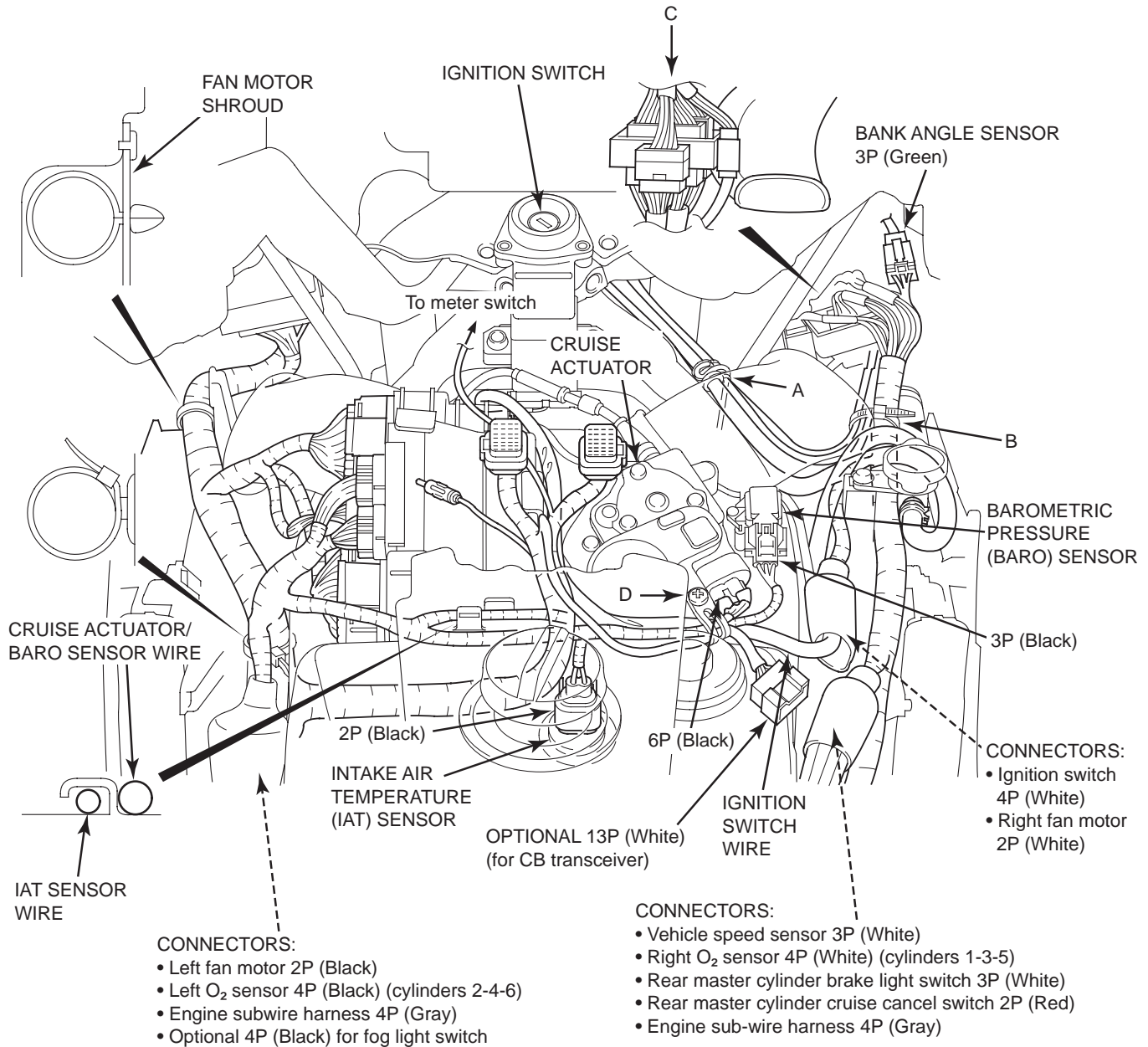

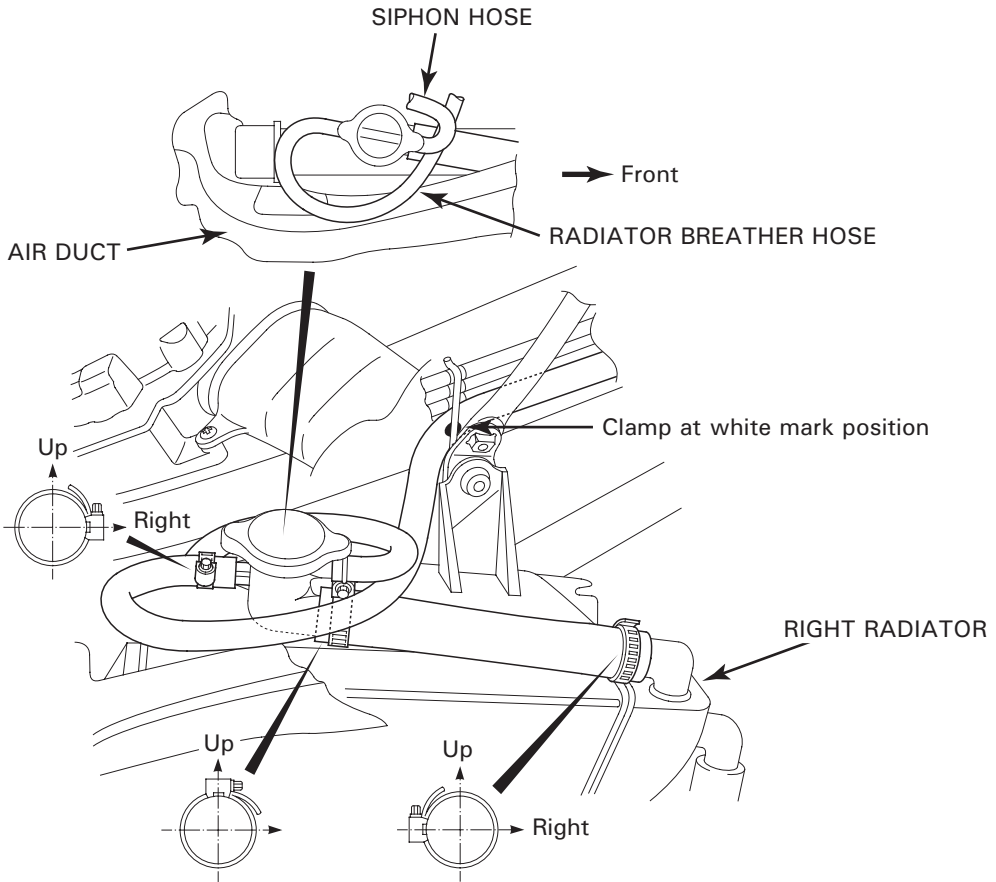
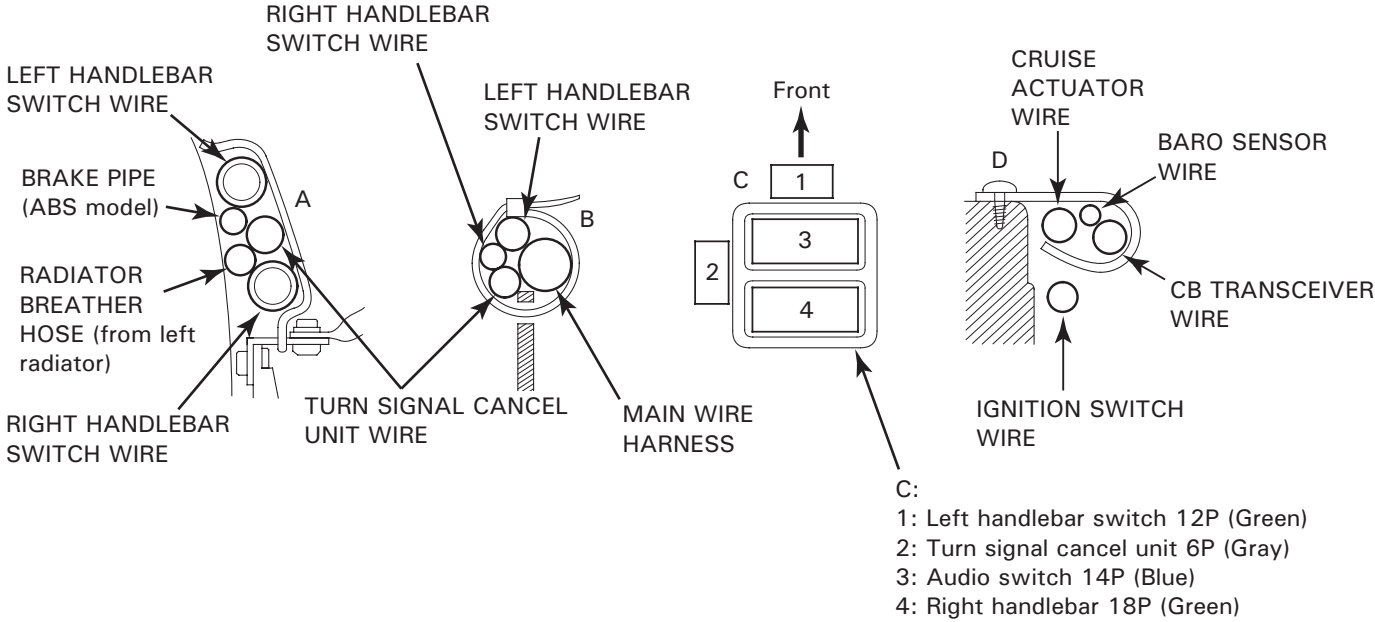

# GENERAL INFORMATION

'03:

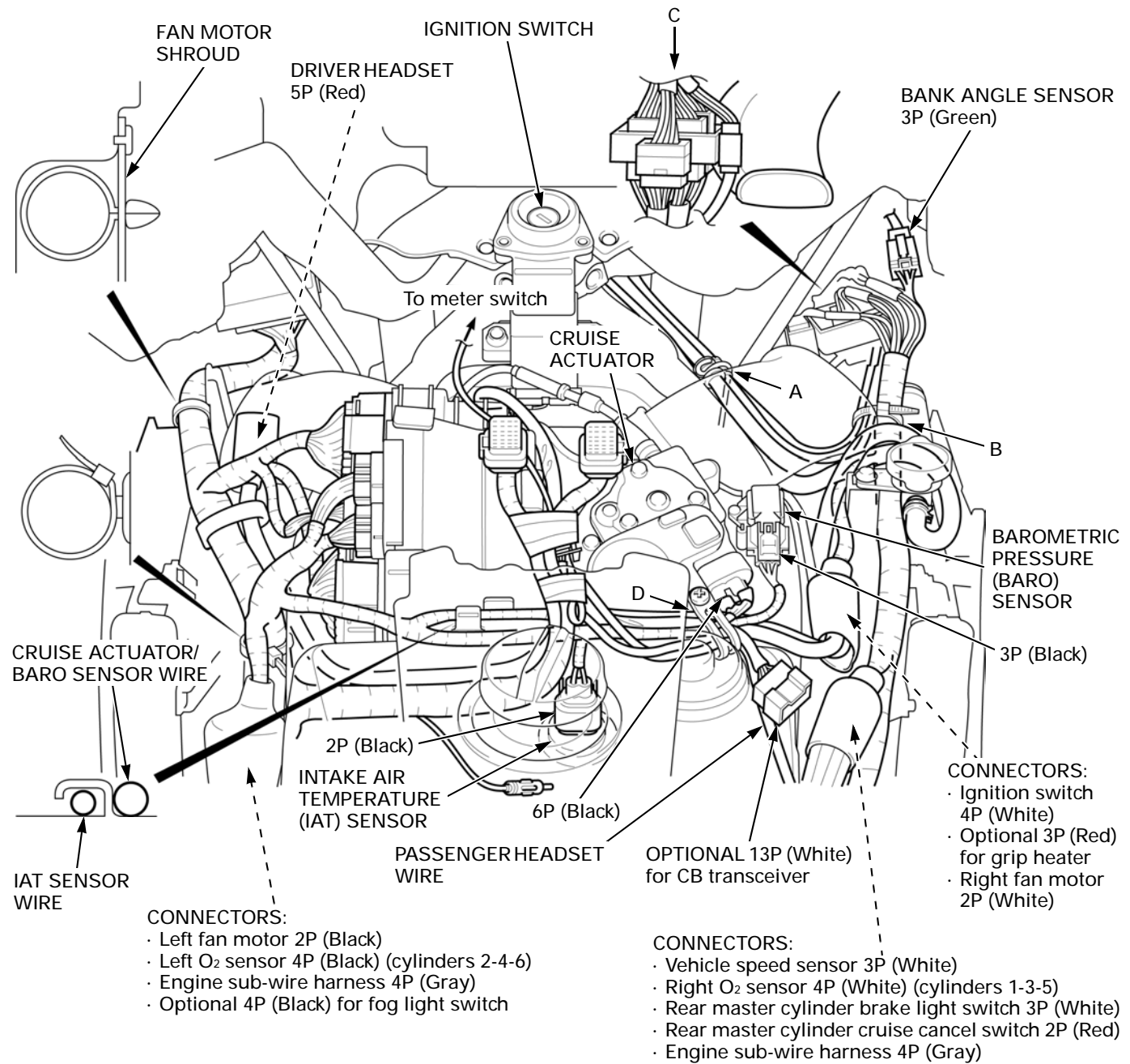

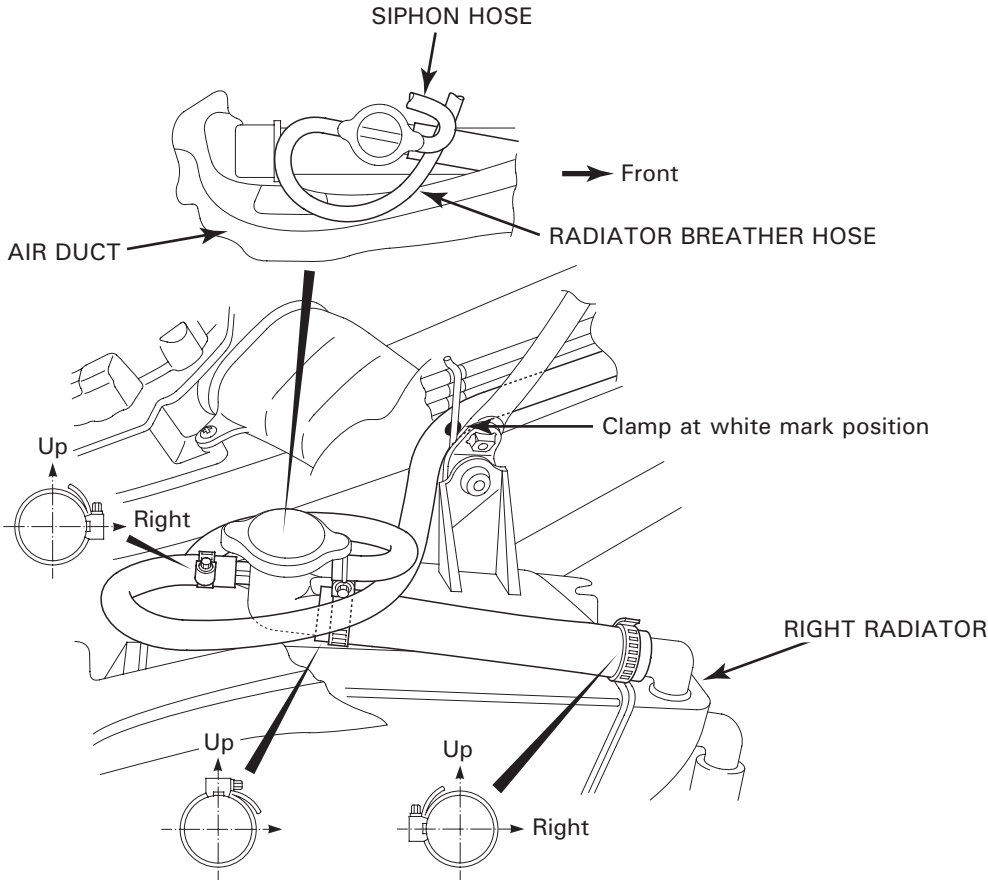
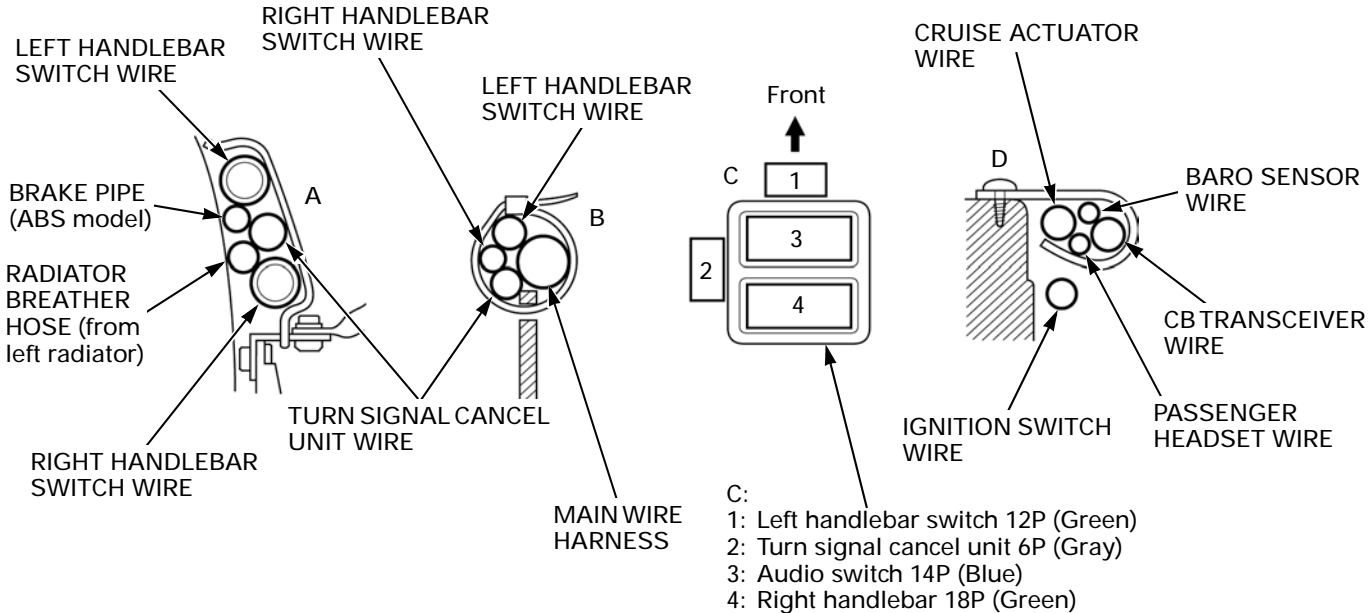

# GENERAL INFORMATION

After '03:

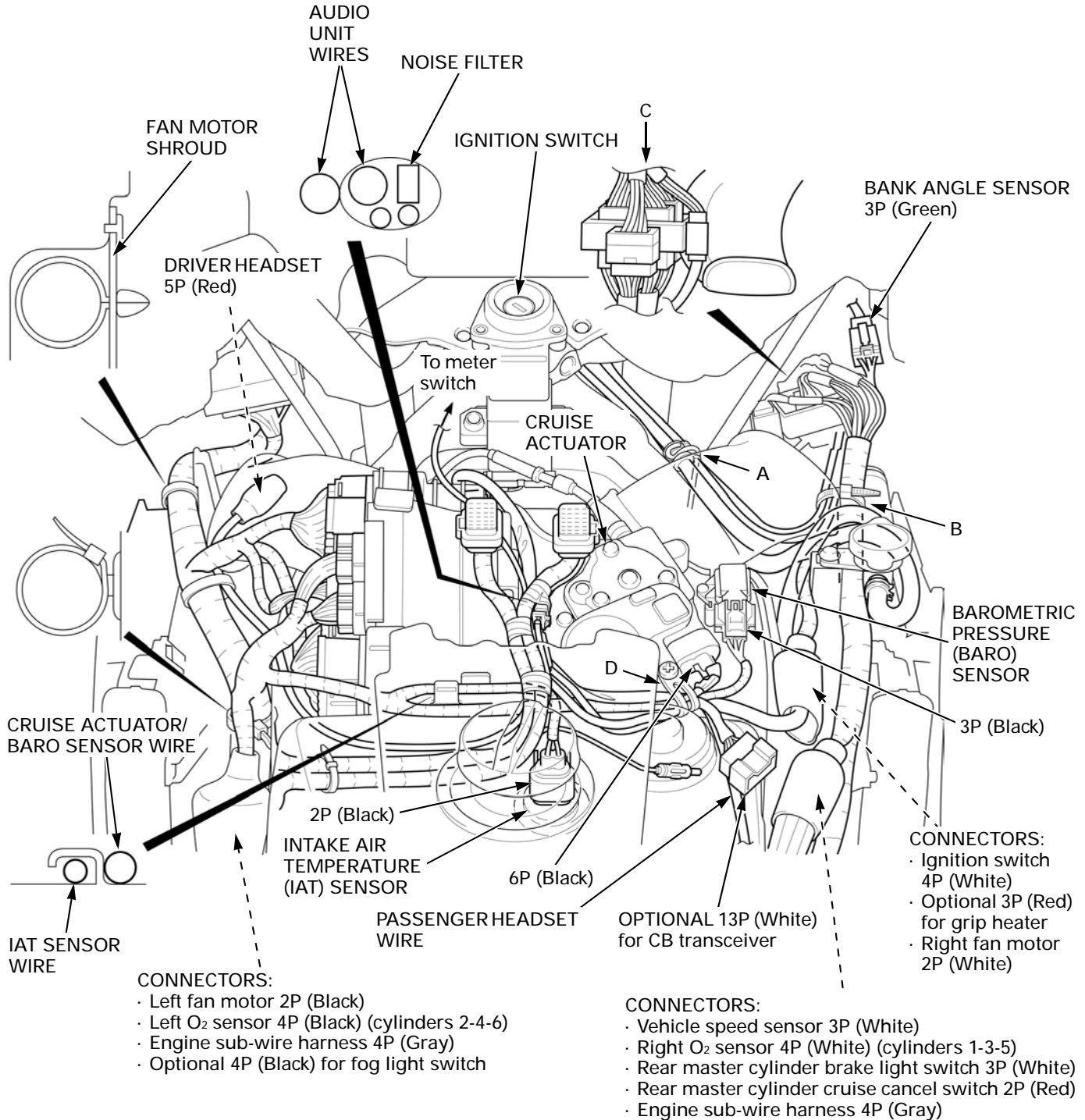

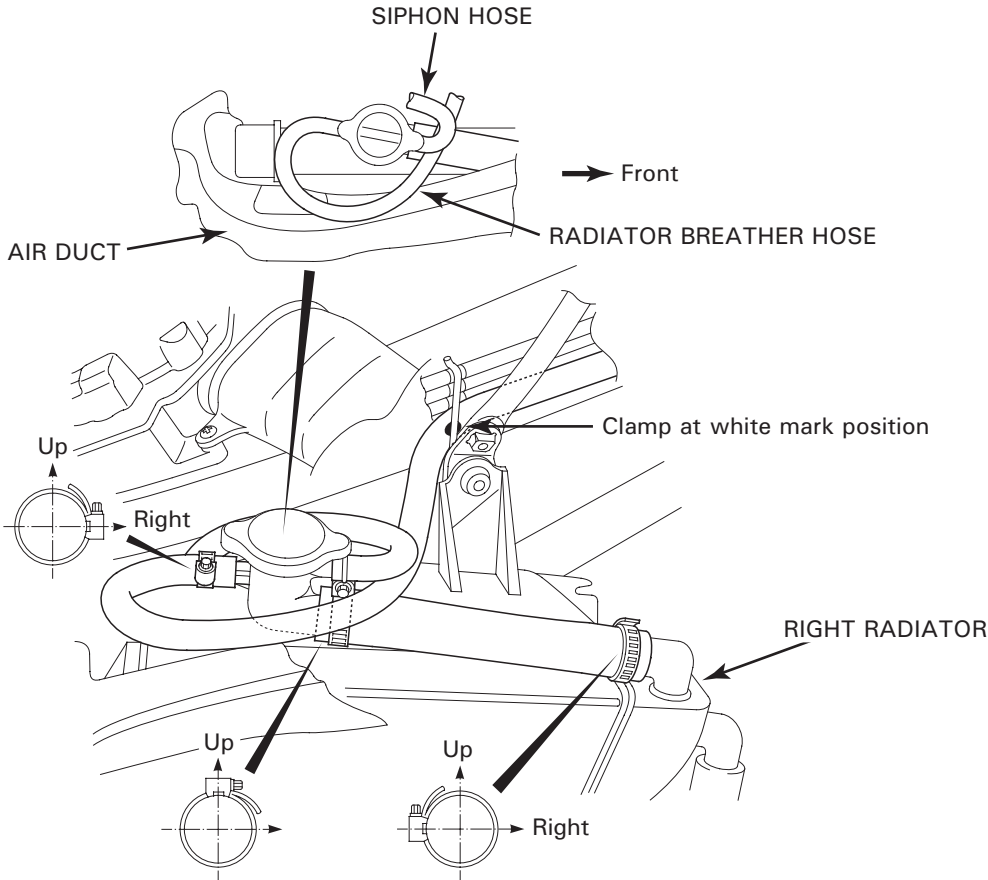
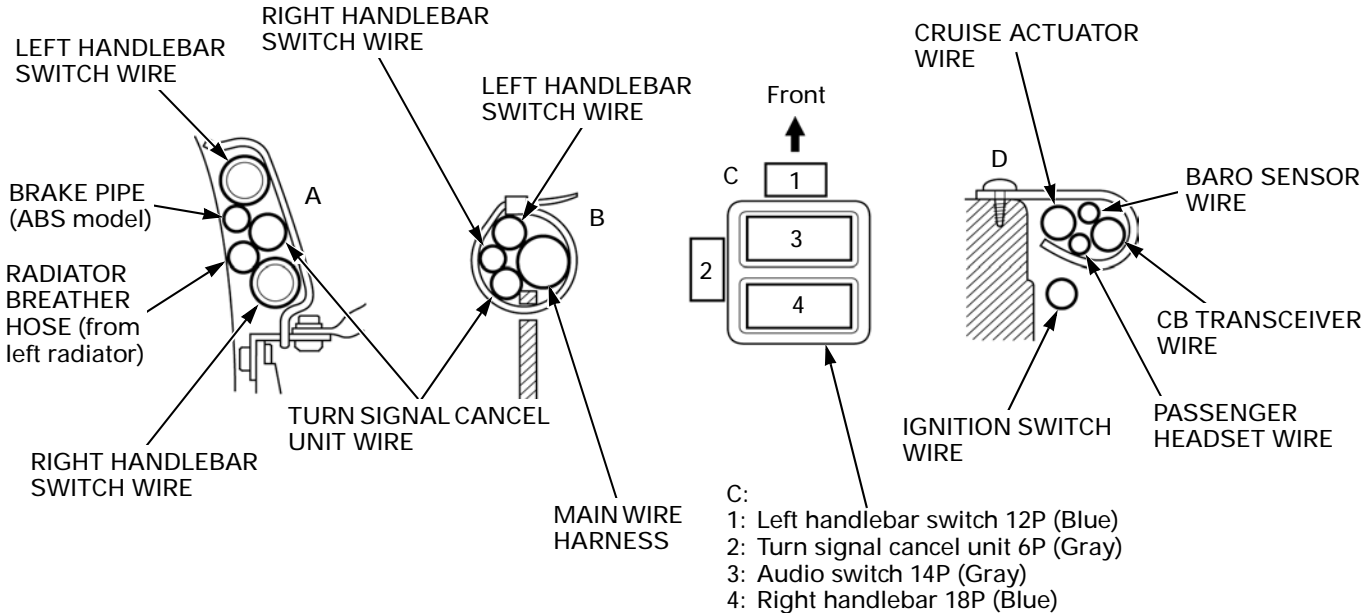

# GENERAL INFORMATION

'01 - '03:

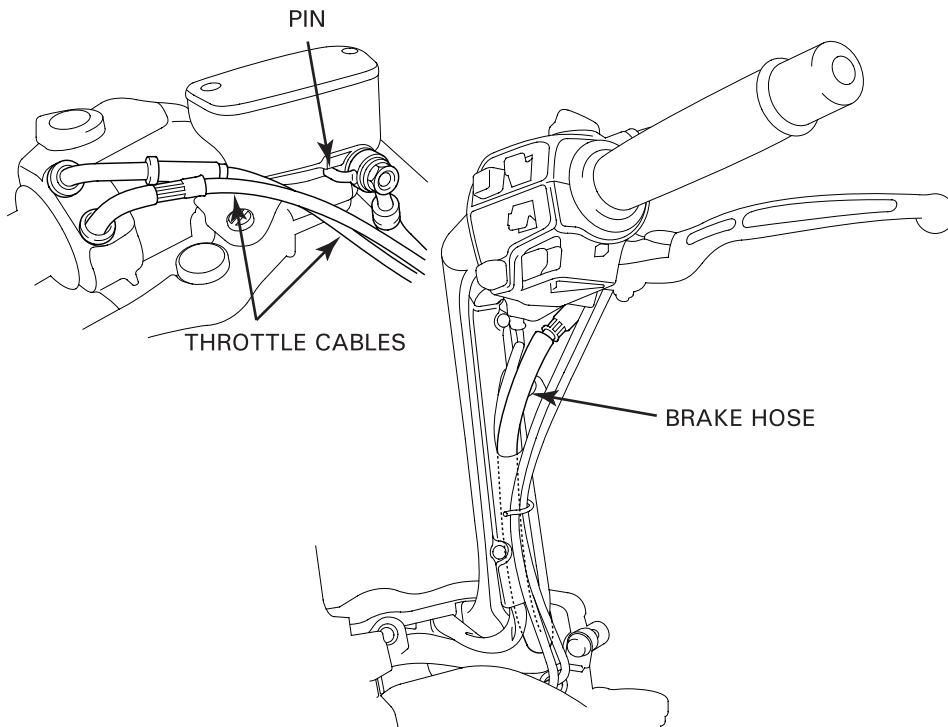
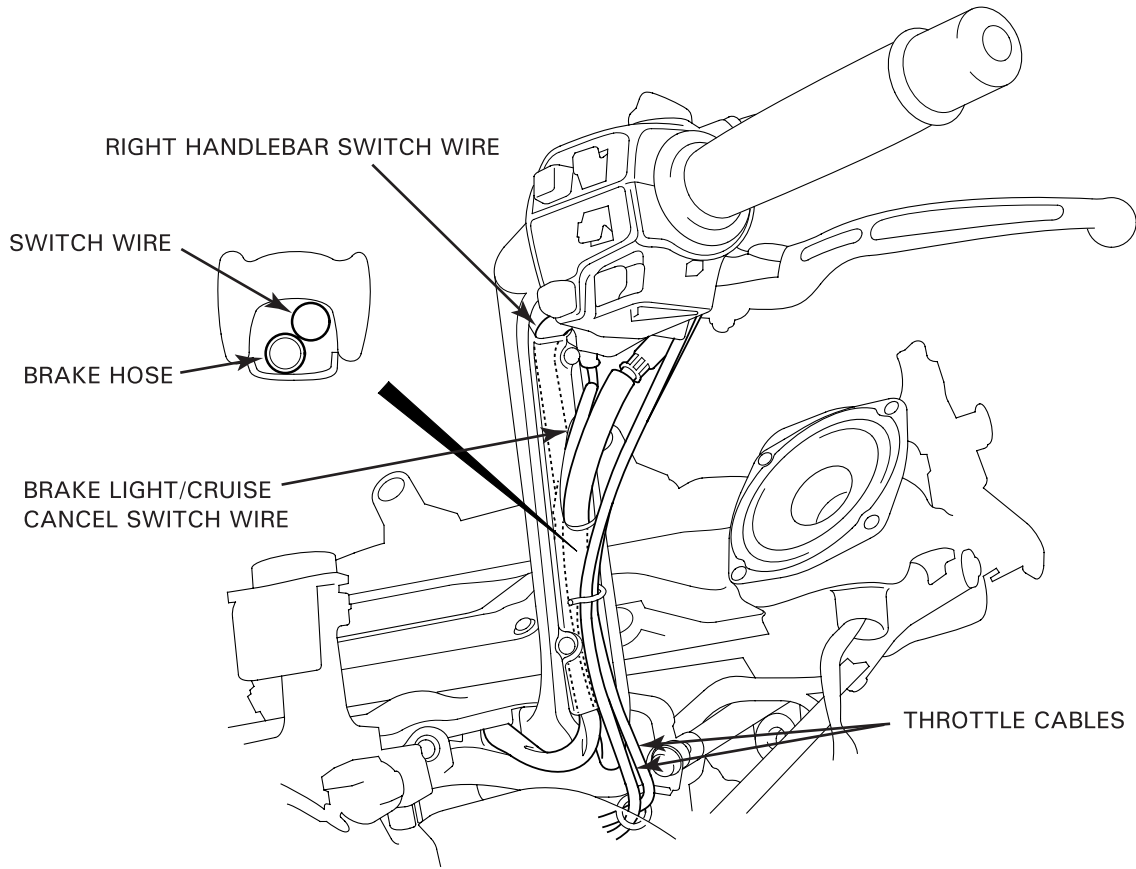

After '03:

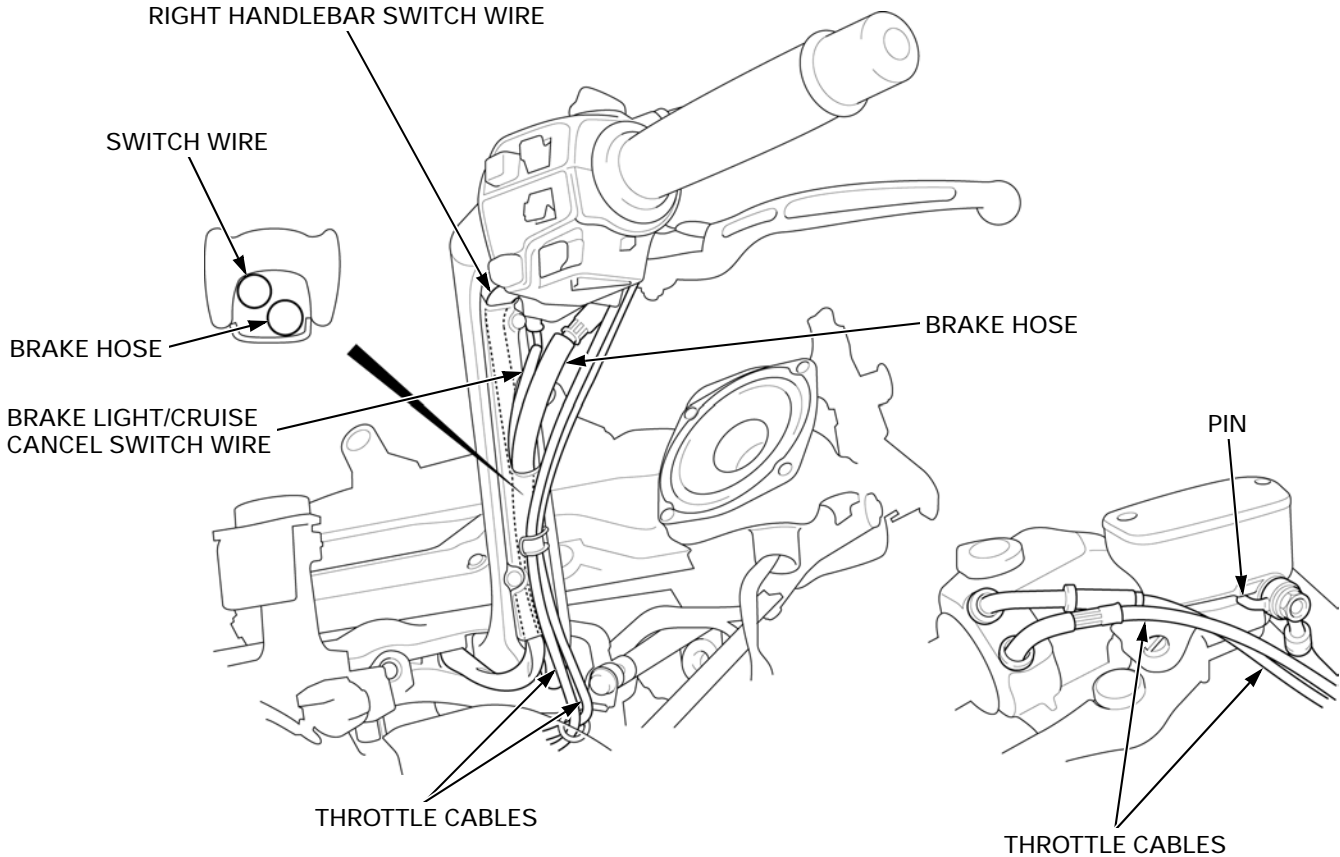



# GENERAL INFORMATION

'01 - '03:

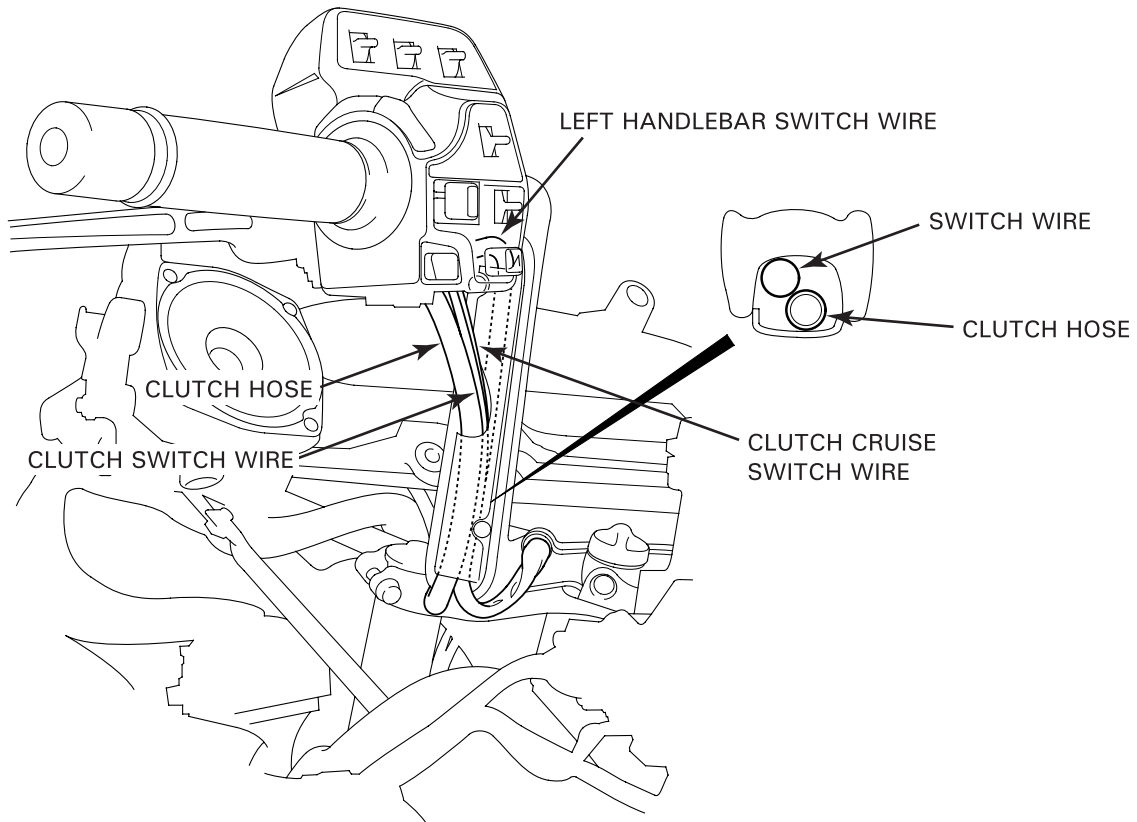

After 03:

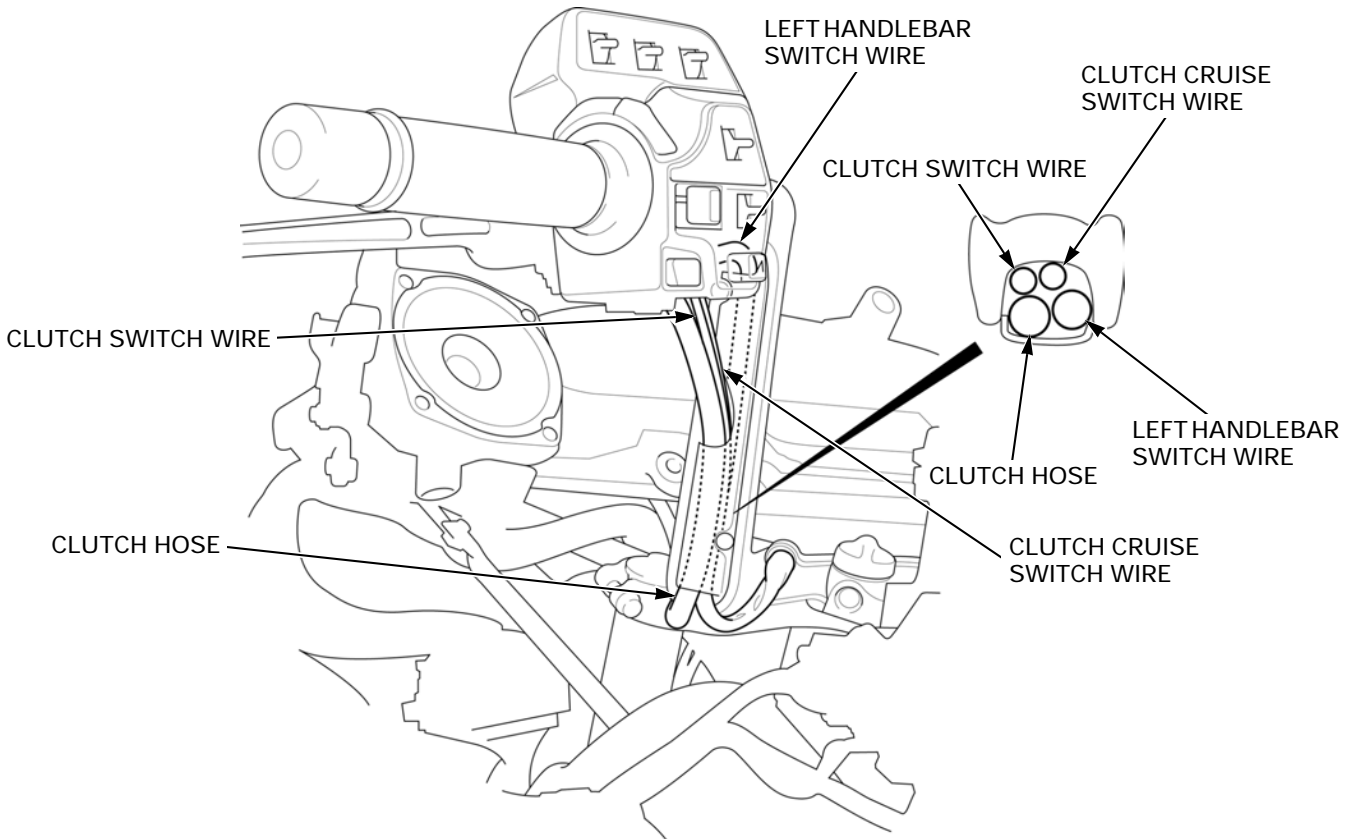

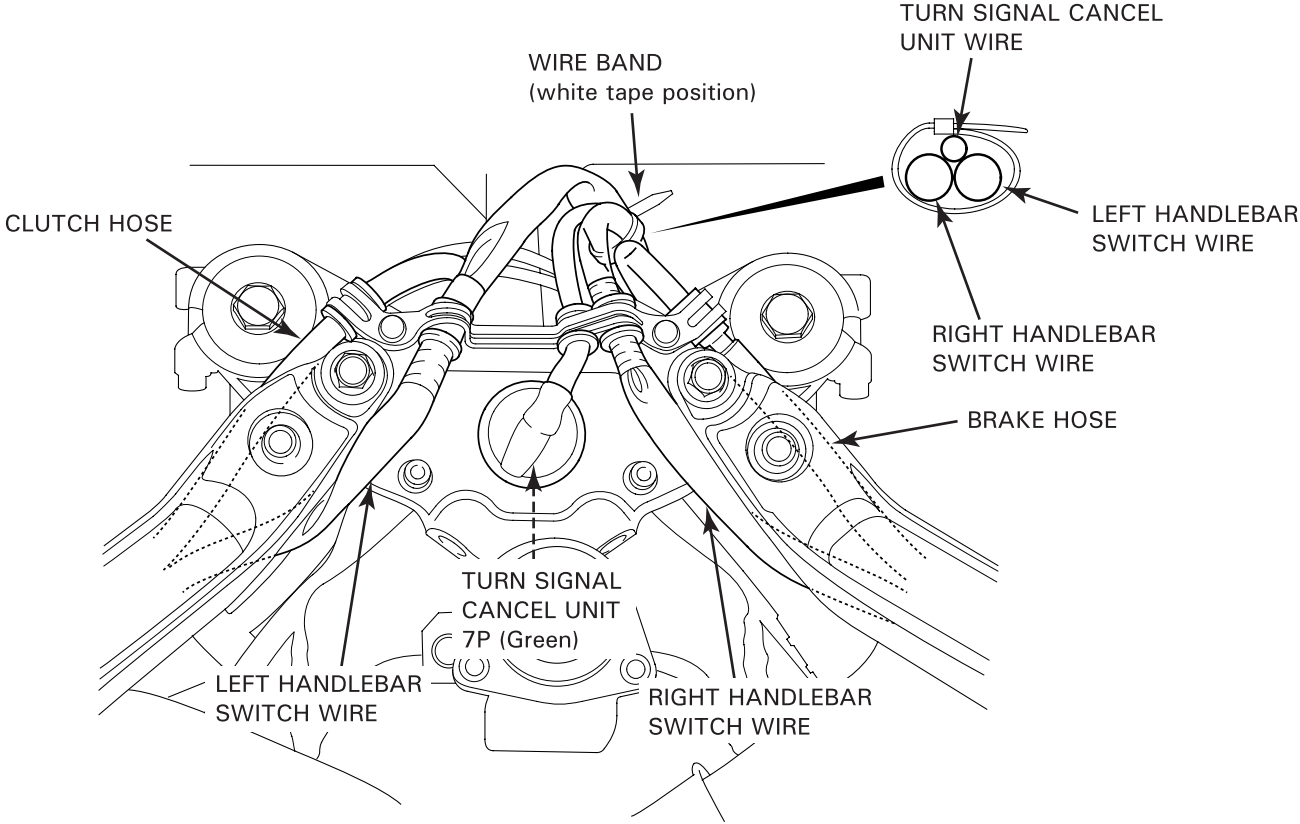

# GENERAL INFORMATION

\*: ABS (Anti-lock Brake System) model

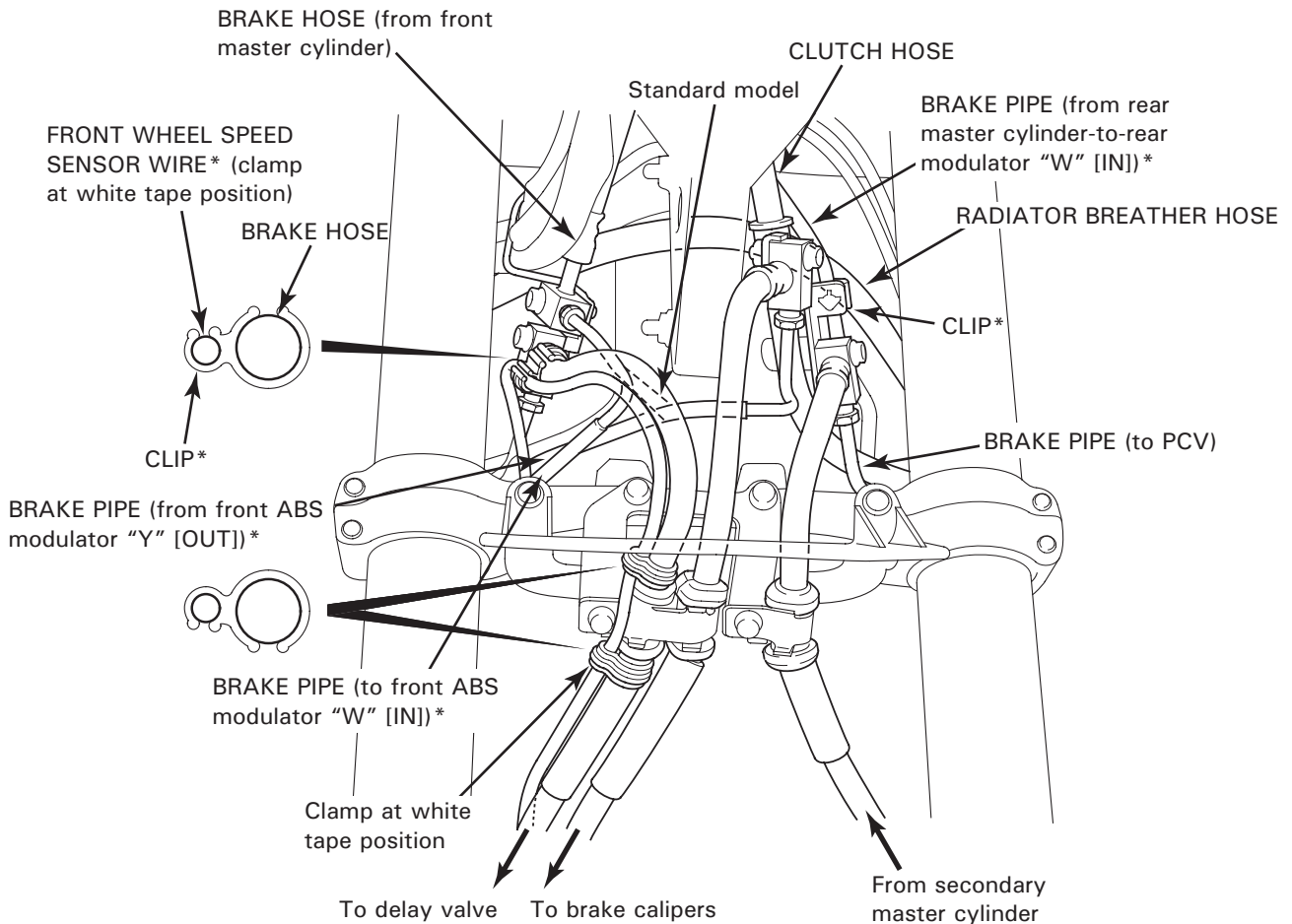
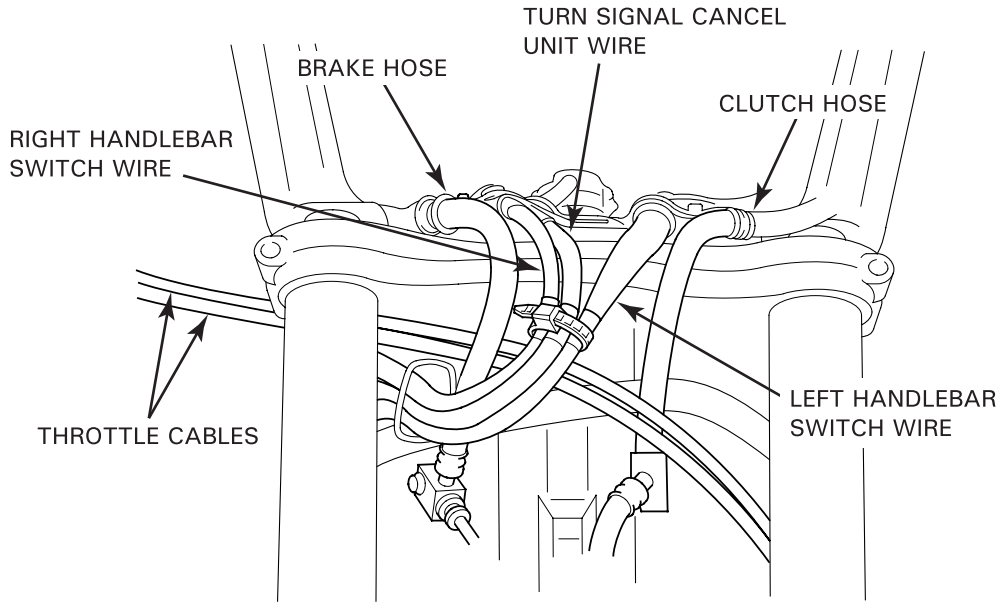

\*: ABS (Anti-lock Brake System) model

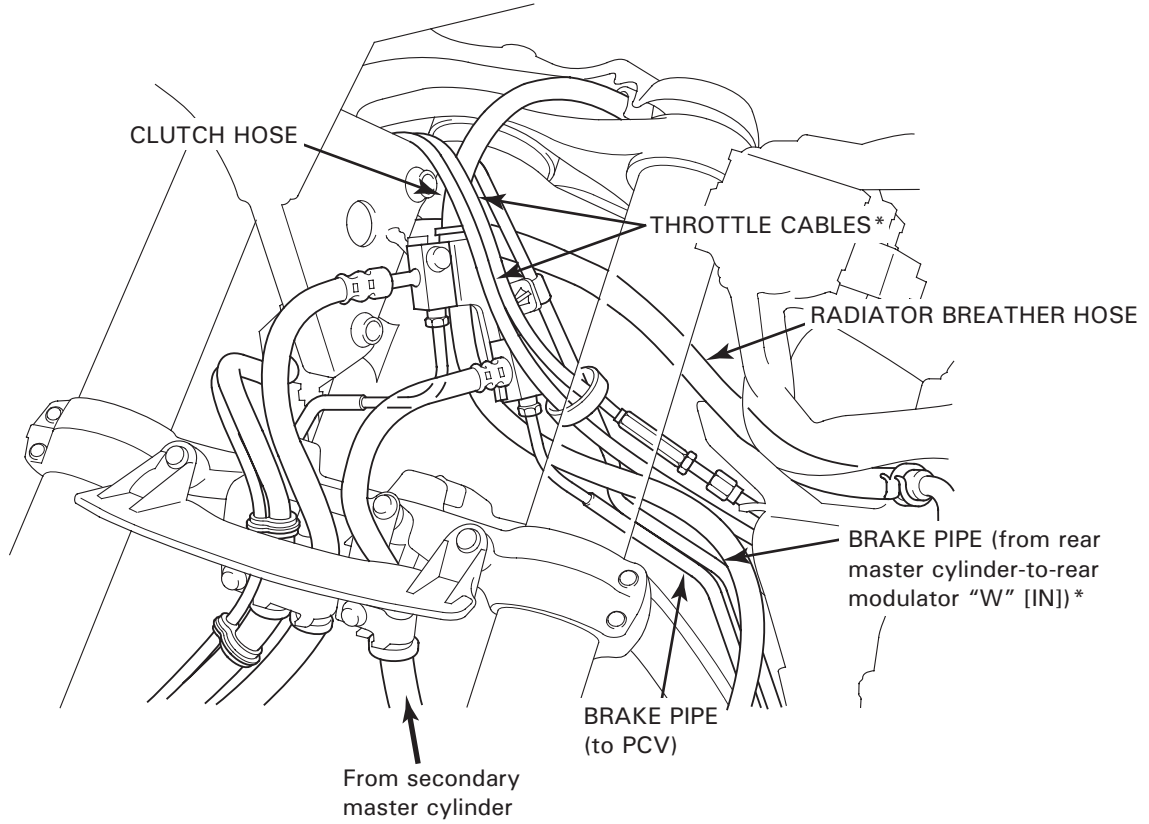

Standard model:

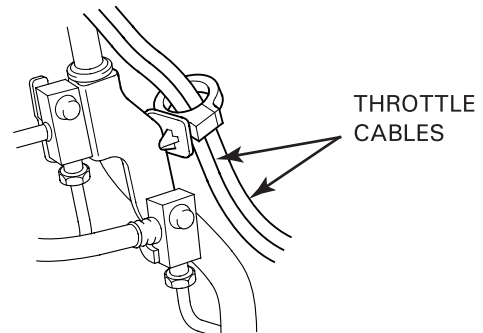

# GENERAL INFORMATION

\*: ABS (Anti-lock Brake System) model

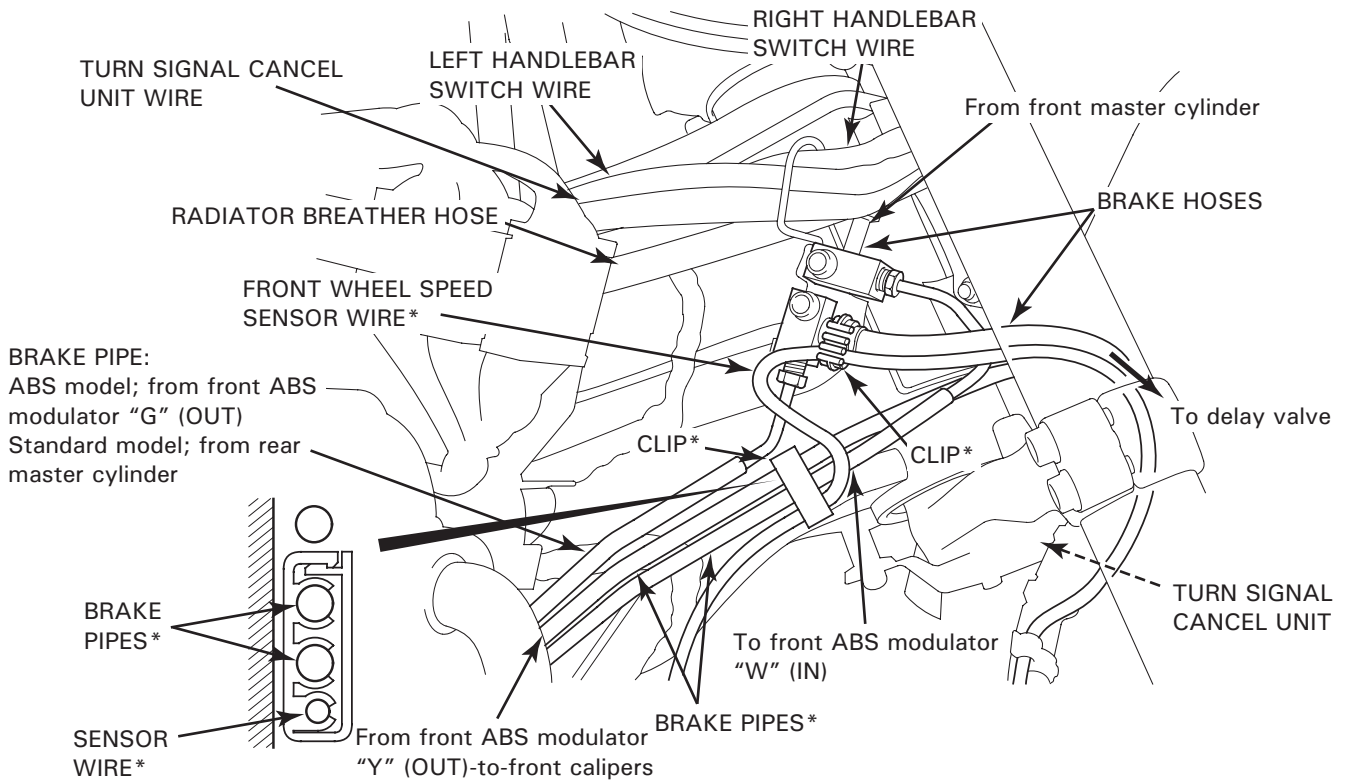
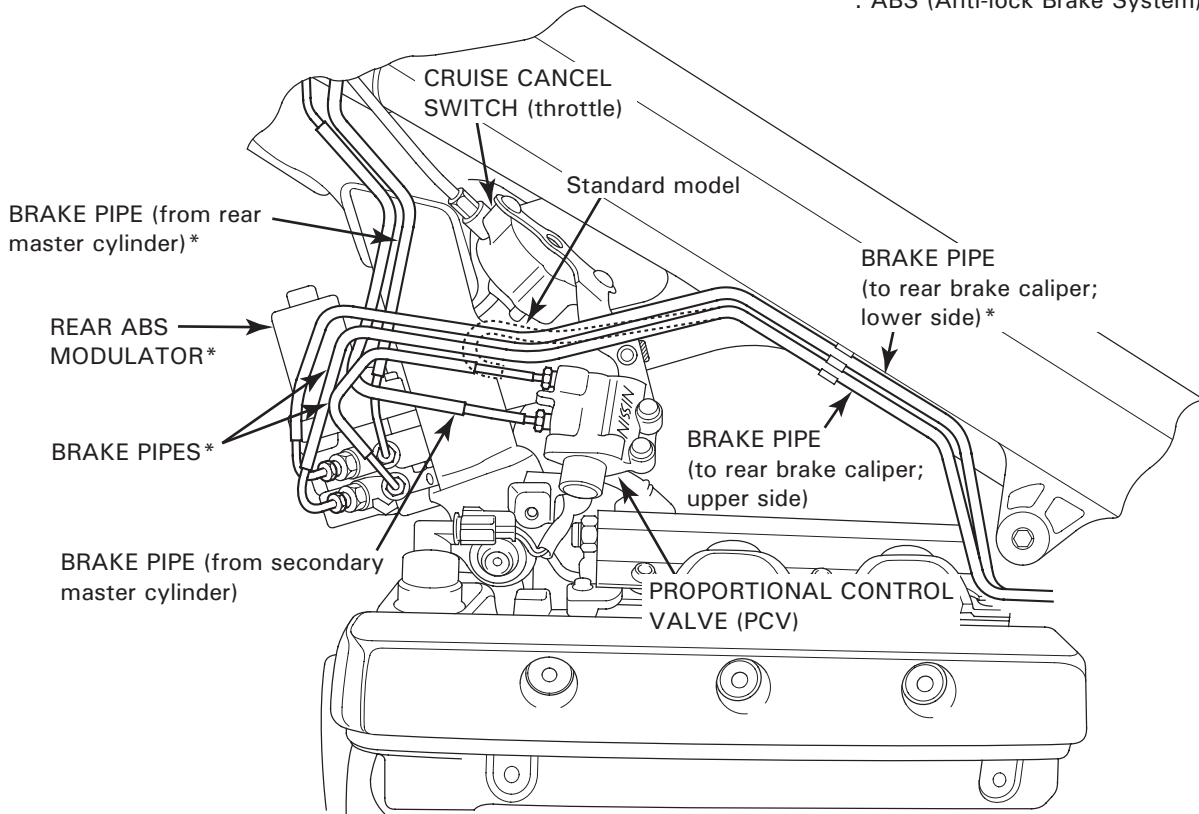

\*: ABS (Anti-lock Brake System) model

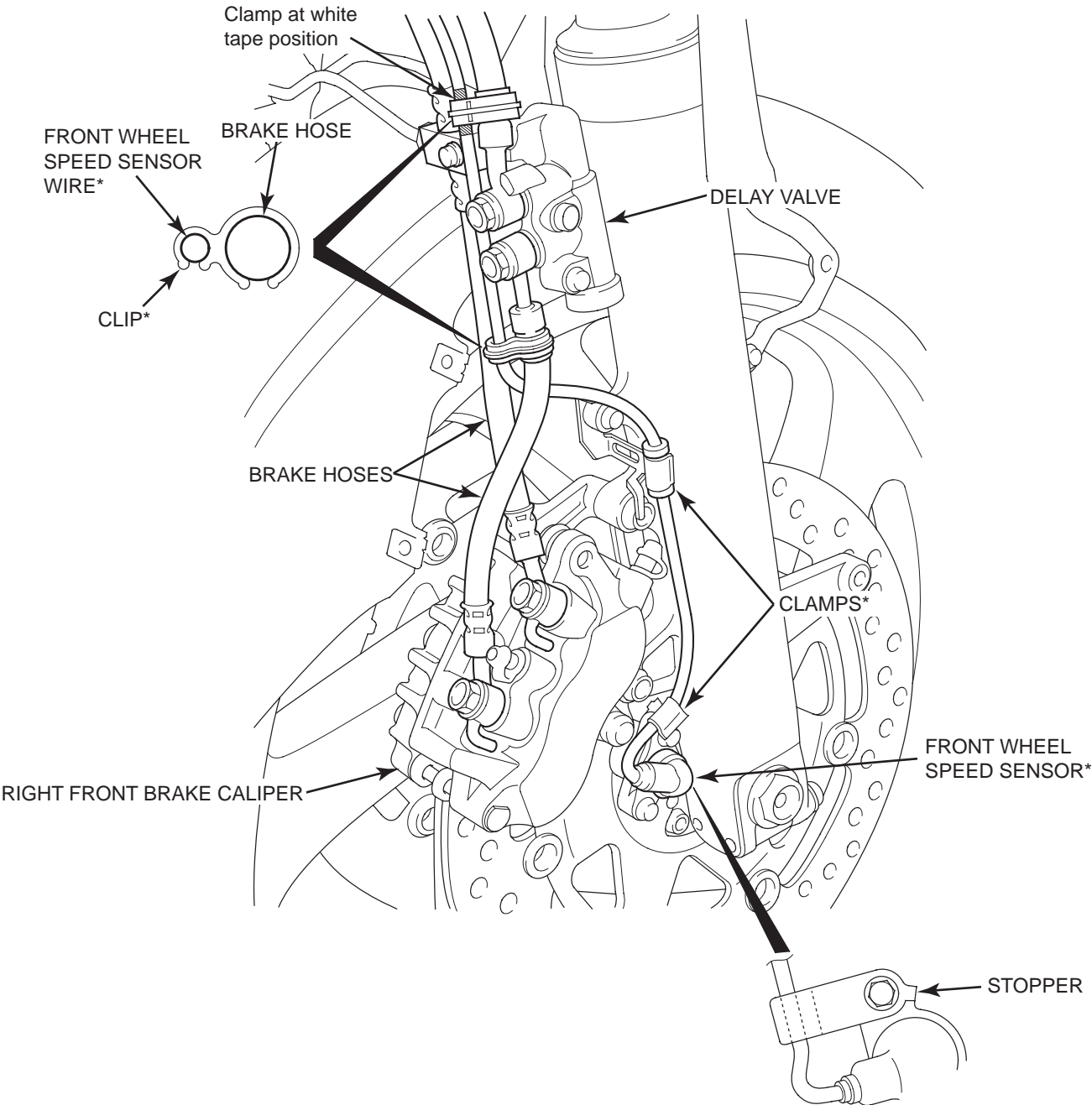

# GENERAL INFORMATION

---

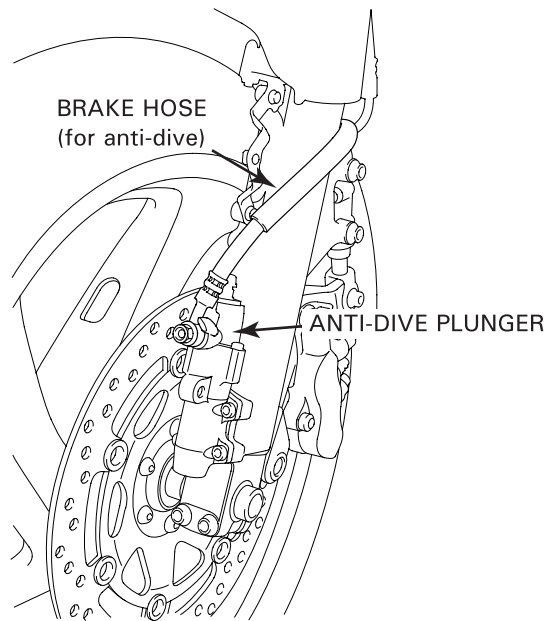
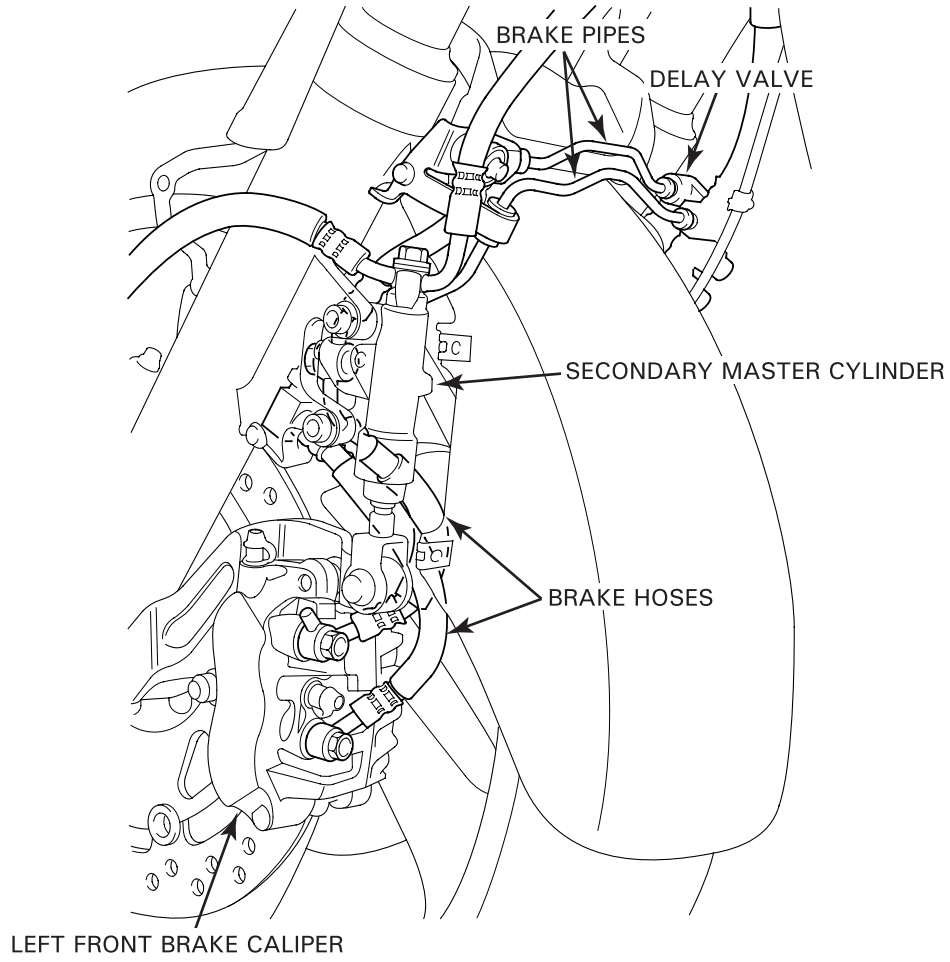

'01, '02:

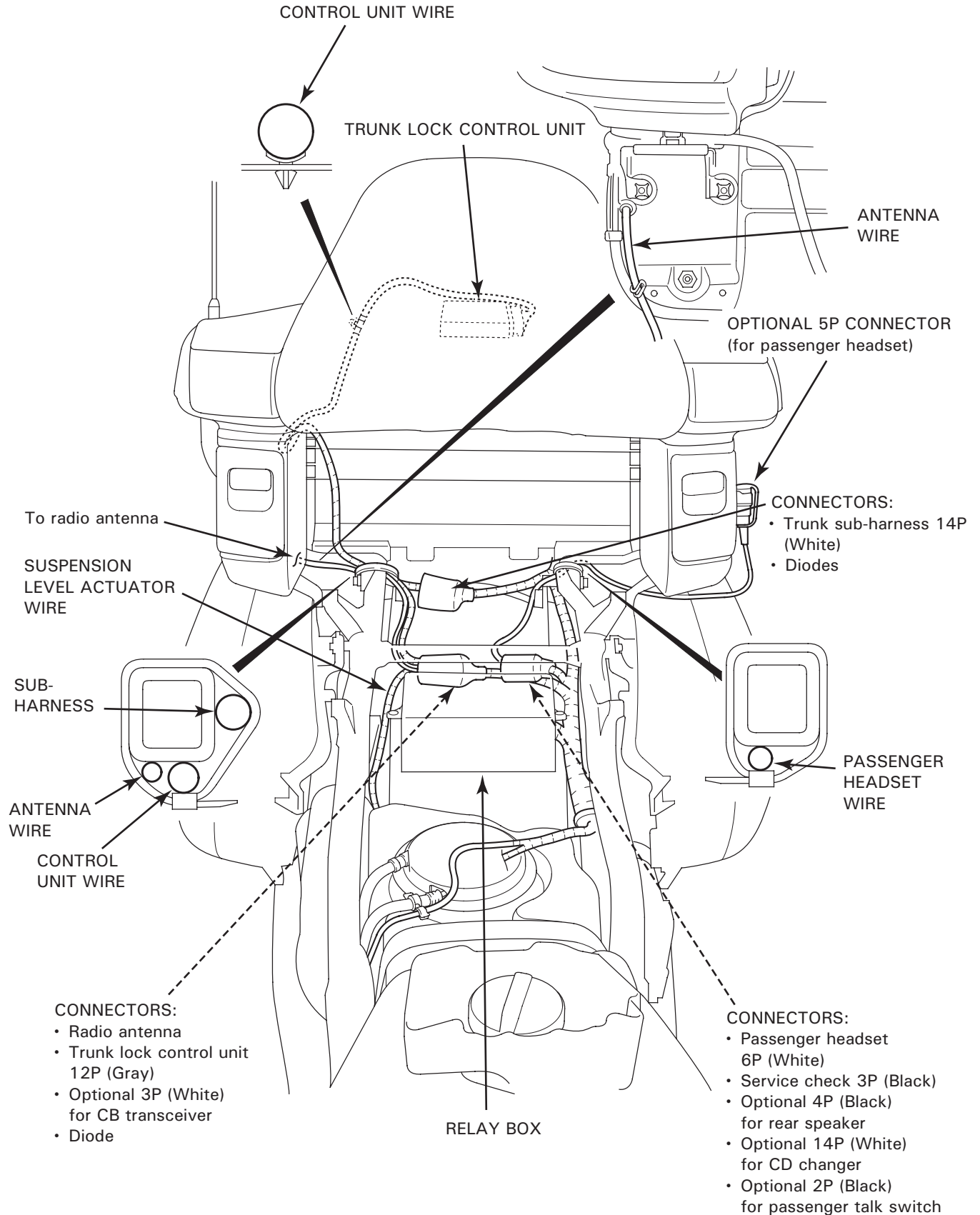



# GENERAL INFORMATION

After '02:

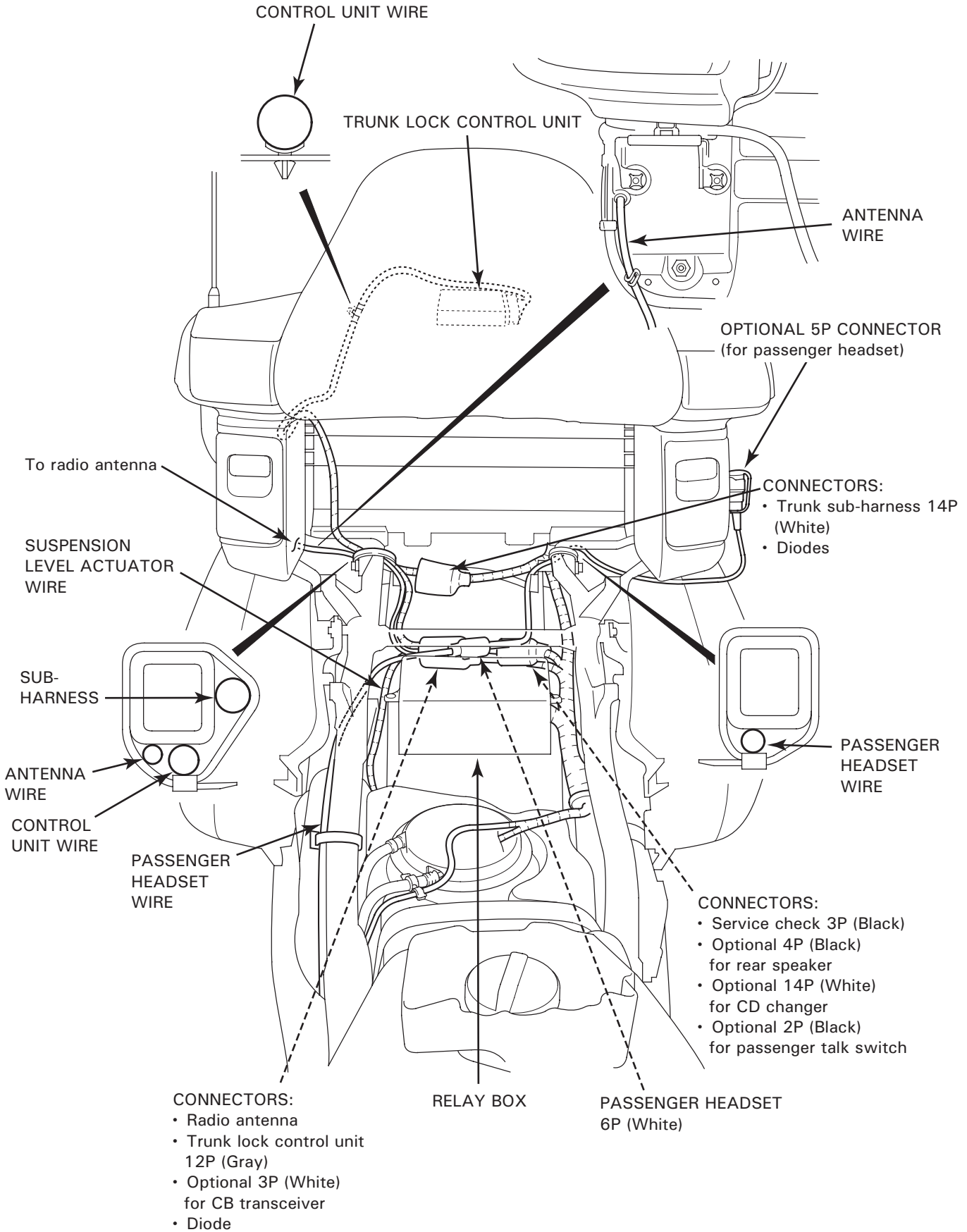

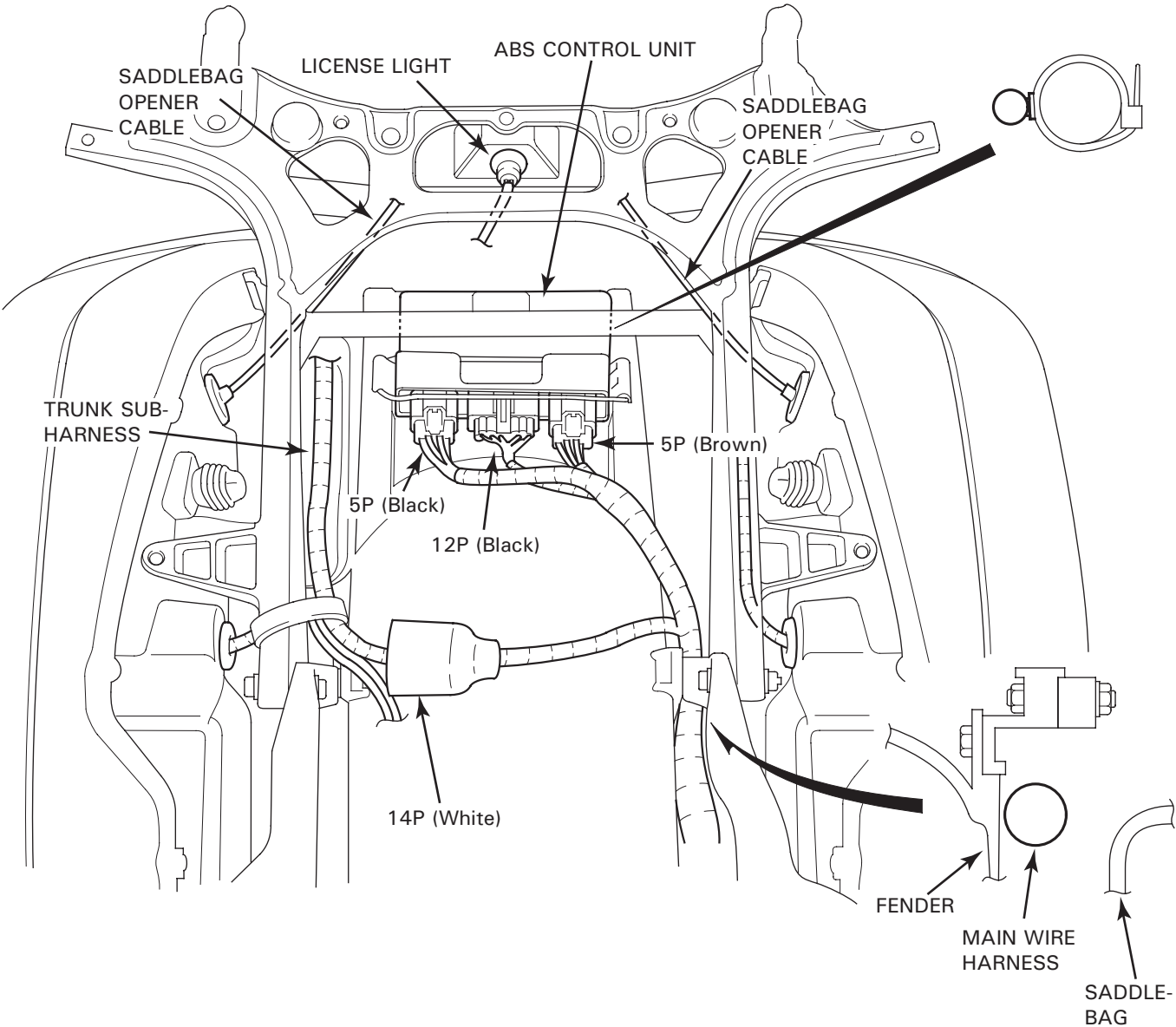

# GENERAL INFORMATION

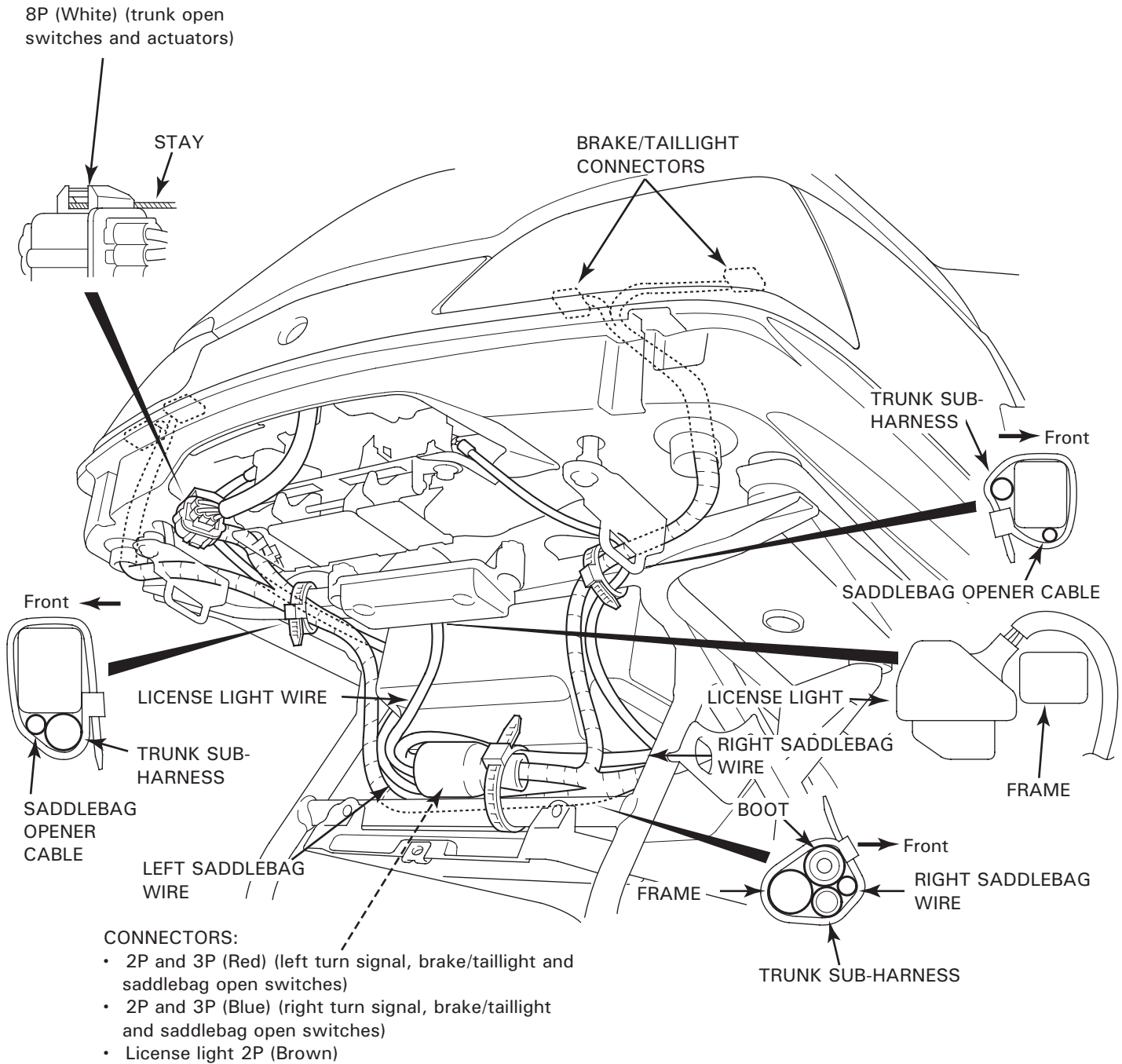

Left saddlebag shown:

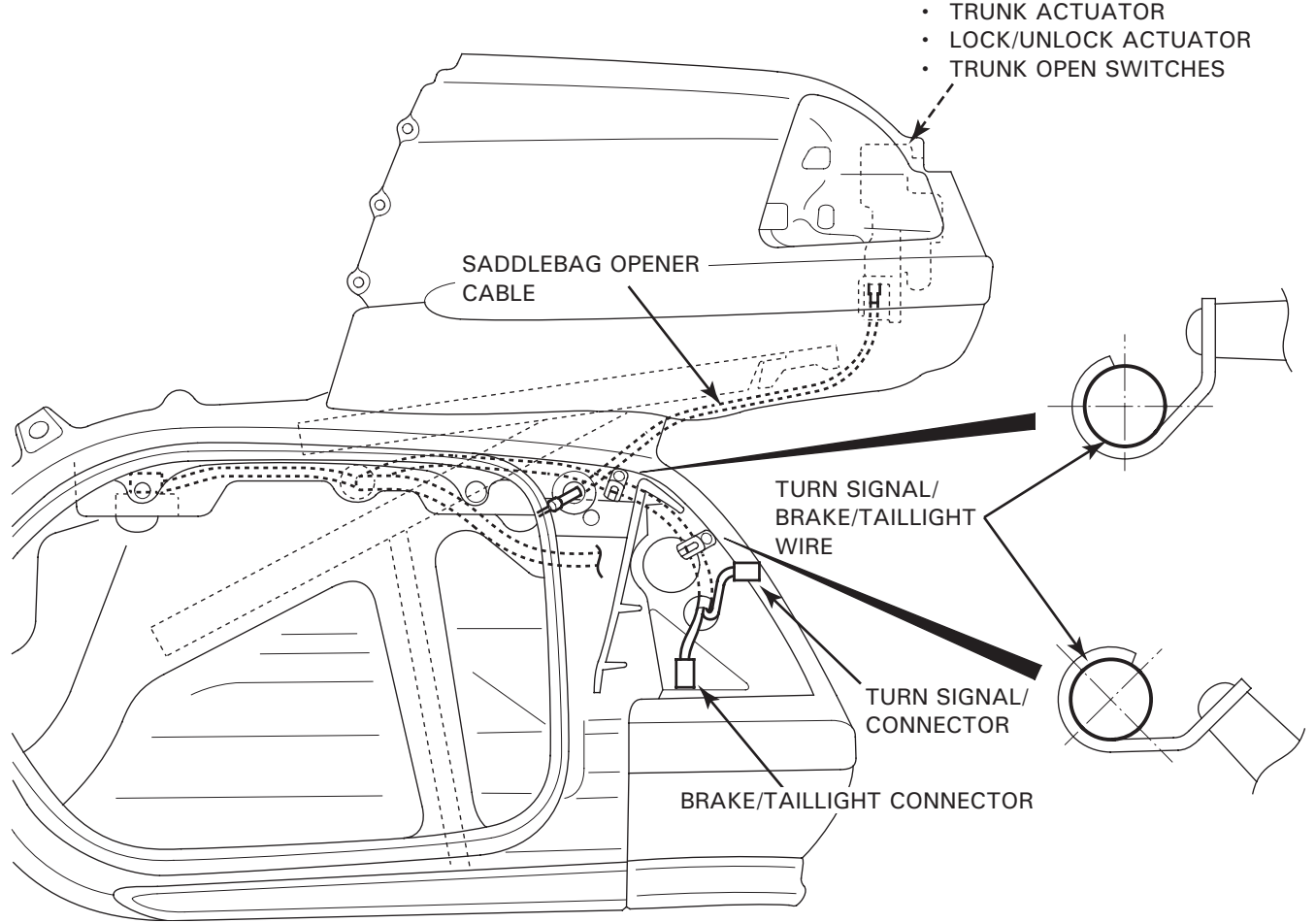
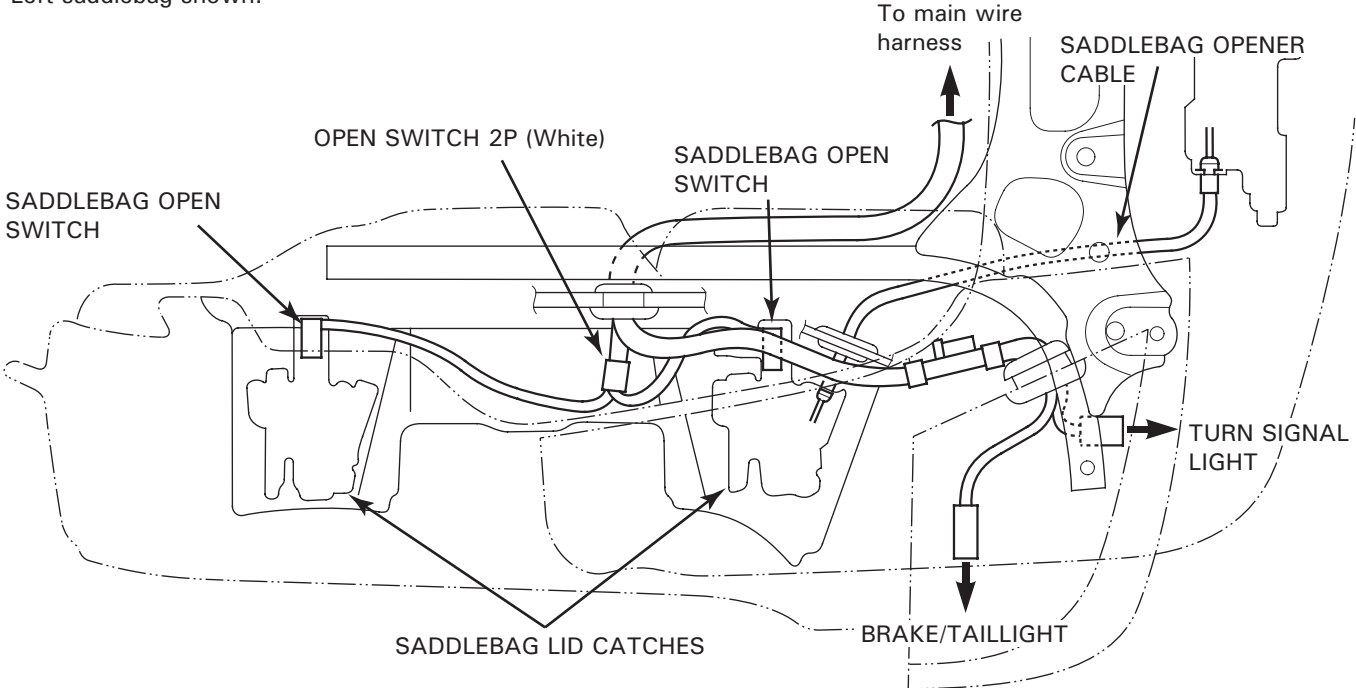

# GENERAL INFORMATION

Inside of trunk lid:

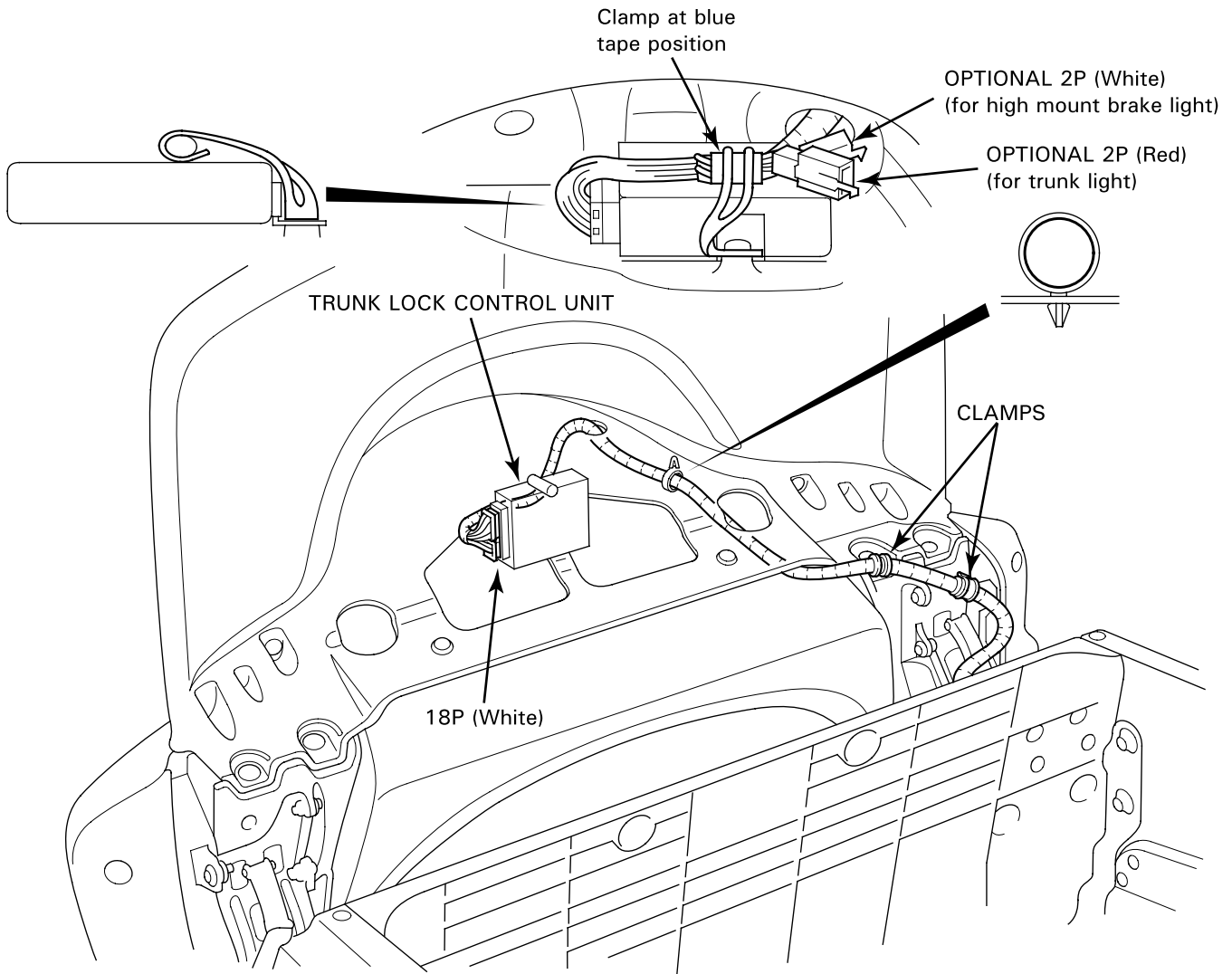

'01:

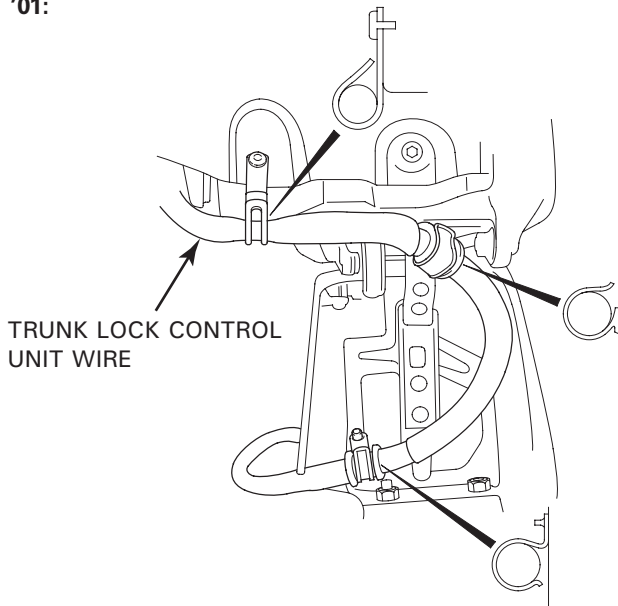

After '01:

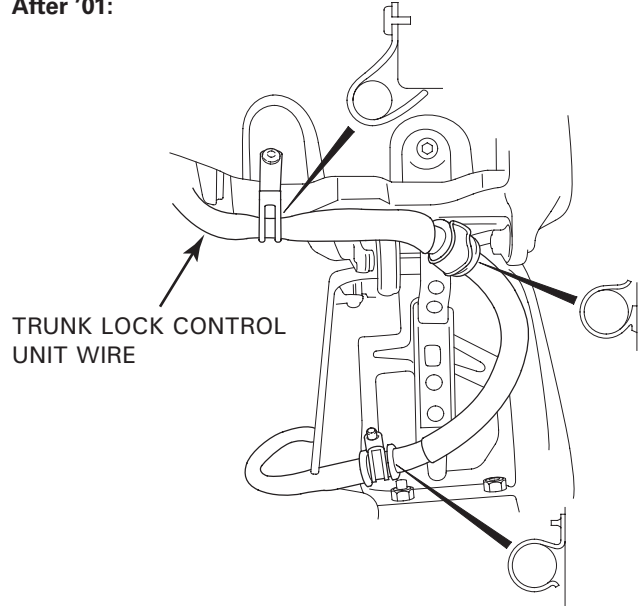

## EMISSION CONTROL SYSTEMS

The U.S. Environmental Protection Agency, Transport Canada and California Air Resources Board (CARB) require manufacturers to certify that their motorcycles comply with applicable exhaust emissions standards during their useful life, when operated and maintained according to the instructions provided, and that motorcycles built after January 1, 1983, comply with applicable noise emission standards for one year or 6,000 km (3,730 miles) after the time of sale to the ultimate purchaser, when operated and maintained according to the instructions provided. Compliance with the terms of the Distributor's Limited Warranty for Honda Motorcycle Emission Control Systems is necessary in order to keep the emissions system warranty in effect.

### SOURCE OF EMISSIONS

The combustion process produces carbon monoxide, hydrocarbons and oxides of nitrogen. Control of hydrocarbons and oxides of nitrogen is very important because, under certain conditions, they react to form photochemical smog when subjected to sunlight. Carbon monoxide does not react in the same way, but is toxic.

Honda Motor Co., Ltd., utilizes PGM-FI, two three-way catalytic converters (one in each exhaust pipe) and two heated oxygen sensors (one in each exhaust pipe) to reduce carbon monoxide, hydrocarbons, and oxides of nitrogen.

### CRANKCASE EMISSION CONTROL SYSTEM

The engine is equipped with a closed crankcase system to prevent discharging crankcase emissions into the atmosphere. Blow-by gas is returned to the combustion chamber through the air cleaner and throttle body.

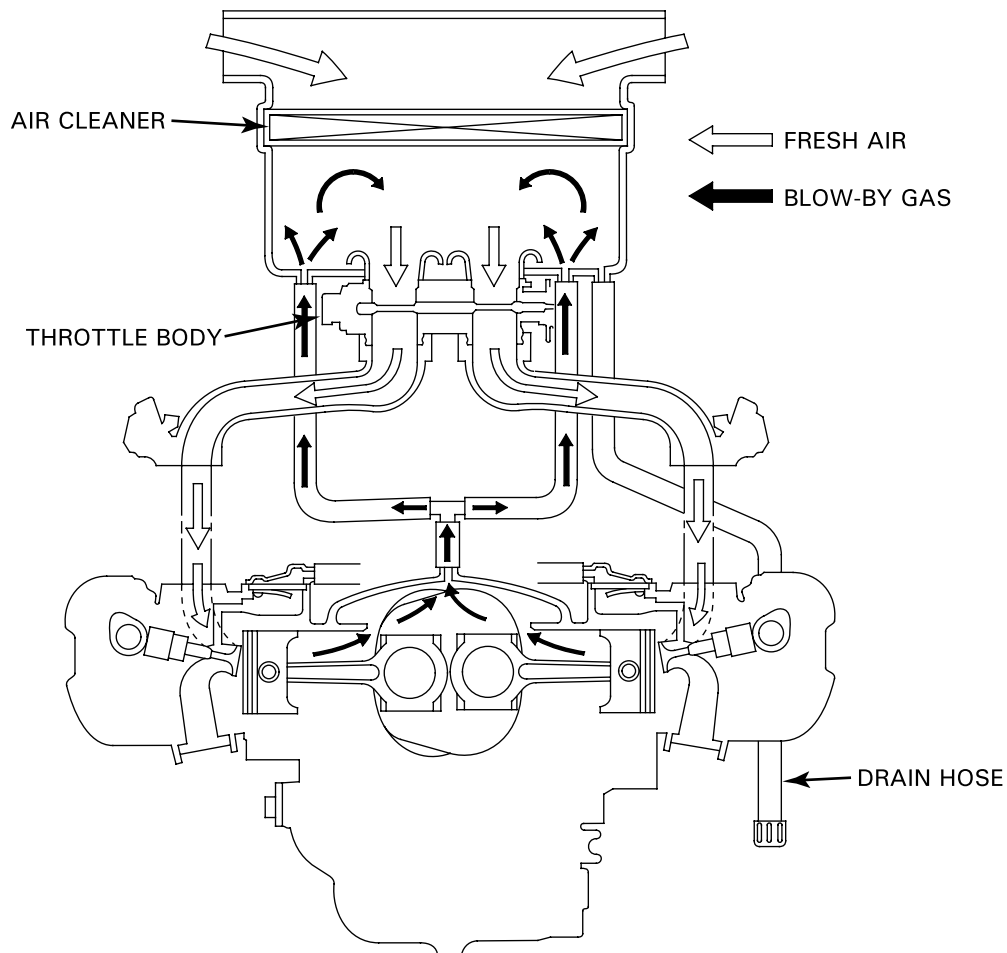

## GENERAL INFORMATION

### EXHAUST EMISSION CONTROL SYSTEM (PULSE SECONDARY AIR INJECTION SYSTEM)

The exhaust emission system is composed of a lean fuel injection setting and a secondary air supply system, no adjustments should be made except idle speed adjustment with the throttle stop screw. The exhaust emission control system is separate from the crankcase emission control system.

The secondary air supply system introduces filtered air into the exhaust gases in the exhaust port. Fresh air is drawn into the exhaust port by the function of the Pulse Secondary Air Injection (PAIR) control valve.

This charge of fresh air promotes burning of the unburned exhaust gases and changes a considerable amount of hydrocarbons and carbon monoxide into relatively harmless carbon dioxide and water vapor.

The reed valve prevents reverse air flow through the system. The PAIR solenoid control valve is controlled by the PGM-FI unit, and the fresh air passage is opened and closed according to the running condition (ECT/IAT/TP/MAP sensor and engine revolution).

No adjustments to the secondary air supply system should be made, although periodic inspection of the components is recommended.

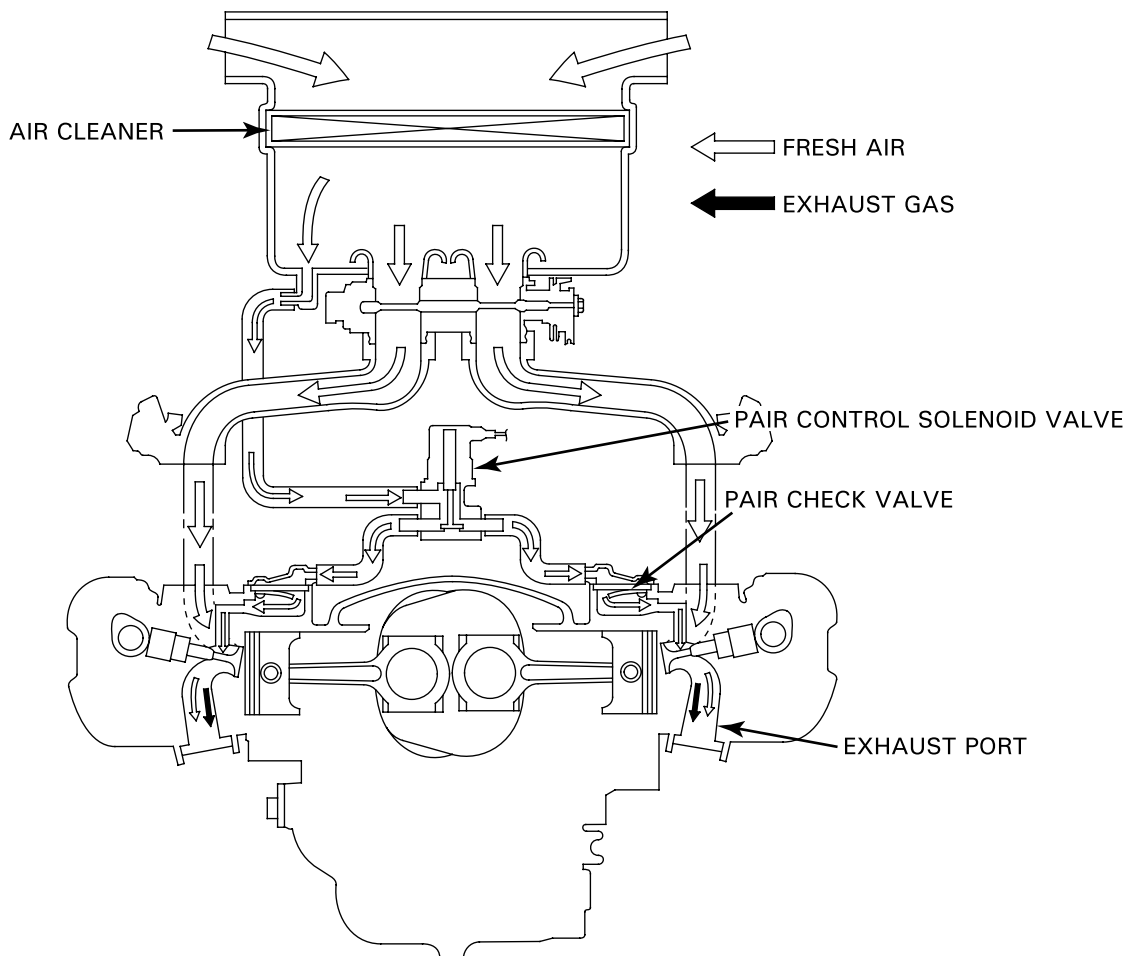

## EVAPORATIVE EMISSION CONTROL SYSTEM

This model complies with California Air Resources Board (CARB) evaporative emission requirements.

Fuel vapor from the fuel tank is routed into the evaporative emission (EVAP) canister where it is absorbed and stored while the engine is stopped. When the engine is running and the EVAP purge control solenoid valve is open, fuel vapor in the EVAP canister is drawn into the engine through the throttle body.

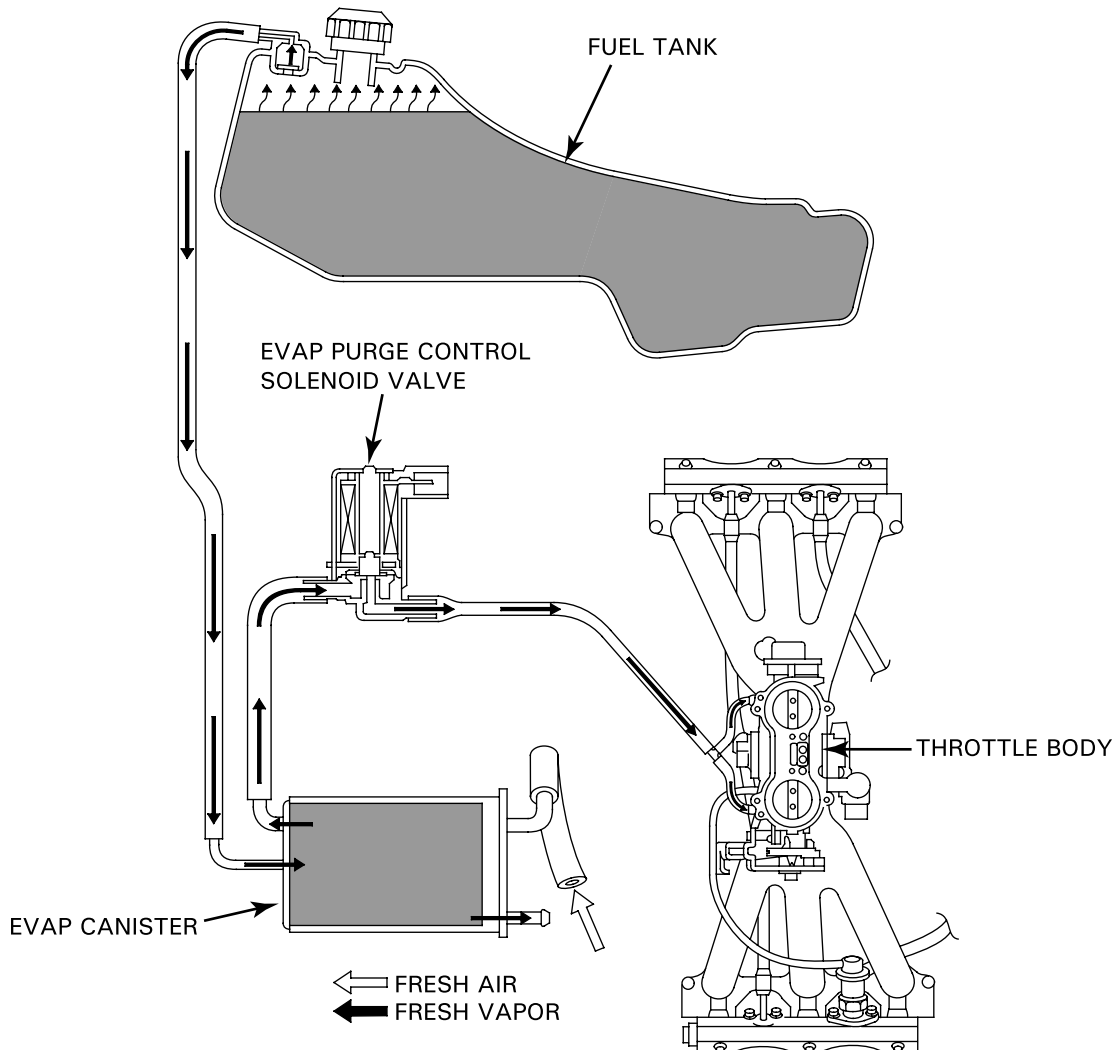

## NOISE EMISSION CONTROL SYSTEM

**TAMPERING WITH THE NOISE EMISSION CONTROL SYSTEM IS PROHIBITED:** U.S. Federal Law prohibits, or Canadian Provincial Law may prohibit the following acts or the causing thereof: (1) The removal or rendering inoperative by any person, other than for the purposes of maintenance, repair or replacement, of any device or element of design incorporated into any vehicle for the purpose of noise control prior to its sale or delivery to the ultimate customer or while it is in use; or (2) the use of any vehicle after such device or element of design has been removed or rendered inoperative by any person.

AMONG THOSE ACTS PRESUMED TO CONSTITUTE TAMPERING ARE THE ACTS LISTED BELOW:

1. Removal of or puncturing of the muffler, baffles, header pipes or any other component which conducts exhaust gases.
2. Removal of or puncturing of any part of the intake system.
3. Lack of proper maintenance.
4. Replacing any moving parts of the vehicle, or parts of the exhaust or intake system, with parts other than those specified by the manufacturer.



## GENERAL INFORMATION

# EMISSION CONTROL INFORMATION LABELS

An Emission Control Information Label is located on the reverse side of the right engine side cover as shown.

It gives basic tune-up specifications.

## VACUUM HOSE ROUTING DIAGRAM LABEL

The Vacuum Hose Routing Diagram Label is located on the reverse side of the right engine side cover.

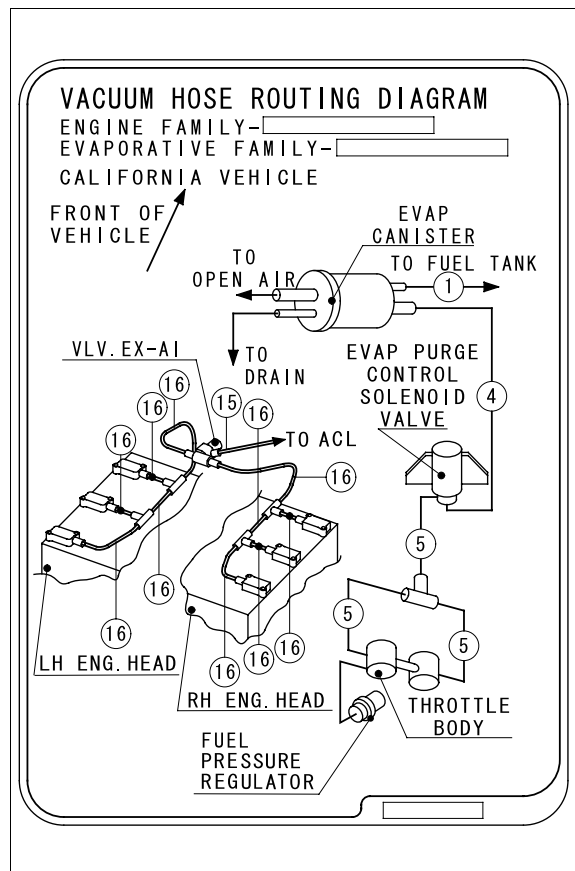
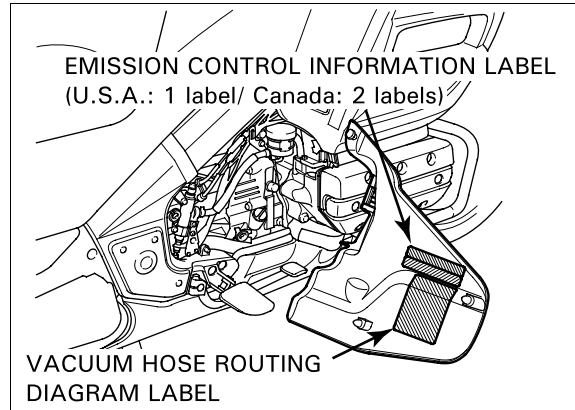

# 2. FRAME/BODY PANELS/EXHAUST SYSTEM

---

SERVICE INFORMATION .....	2-2	INNER FAIRING .....	2-10
TROUBLESHOOTING .....	2-2	FRONT FAIRING .....	2-10
BODY PANEL LOCATIONS .....	2-3	TOP SHELTER.....	2-11
SIDE COVER.....	2-5	REAR FENDER A.....	2-13
ENGINE SIDE COVER.....	2-5	TRUNK LOWER COVER .....	2-13
SEAT.....	2-5	TRUNK .....	2-13
FRONT FENDER COVERS .....	2-6	SADDLEBAGS .....	2-15
FRONT LOWER FAIRING .....	2-6	REAR FENDER B.....	2-16
METER PANEL .....	2-7	SADDLEBAG/TRUNK STAY .....	2-17
REARVIEW MIRROR.....	2-7	EXHAUST SYSTEM.....	2-18
WINDSHIELD .....	2-8		

# SERVICE INFORMATION

## GENERAL

- This section covers removal and installation of the body panels and exhaust system.
- Always replace the gaskets when removing the exhaust system.
- Always inspect the exhaust system for leaks after installation.

## TORQUE VALUES

Saddlebag/trunk stay bolt	26 N·m (2.7 kgf·m, 20 lbf·ft)
Exhaust pipe joint nut	12 N·m (1.2 kgf·m, 9 lbf·ft)
Exhaust pipe mounting bolt	26 N·m (2.7 kgf·m, 20 lbf·ft)
Exhaust pipe band bolt	26 N·m (2.7 kgf·m, 20 lbf·ft)
Muffler band bolt	26 N·m (2.7 kgf·m, 20 lbf·ft)
Front exhaust pipe protector bolt	12 N·m (1.2 kgf·m, 9 lbf·ft)
Rear exhaust pipe protector bolt	14 N·m (1.4 kgf·m, 10 lbf·ft)

## TROUBLESHOOTING

### Excessive exhaust noise

- Broken exhaust system
- Exhaust gas leaks

### Poor performance

- Deformed exhaust system
- Exhaust gas leaks
- Clogged muffler

**BODY PANEL LOCATIONS**

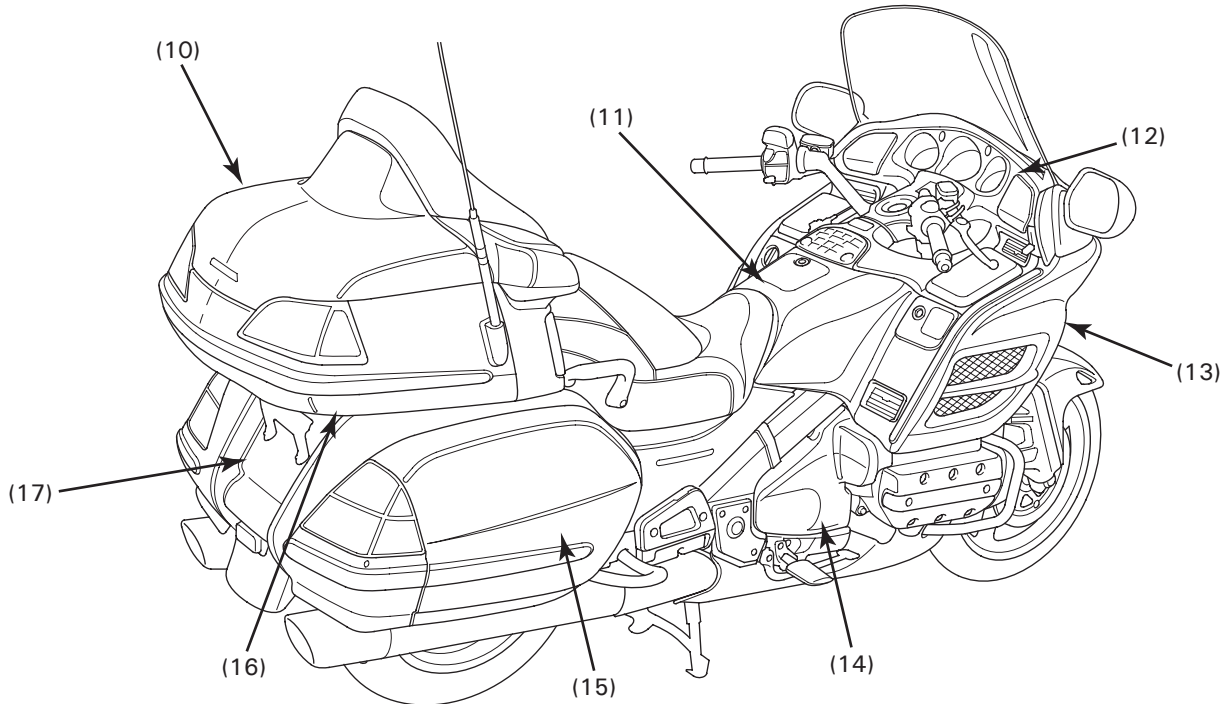
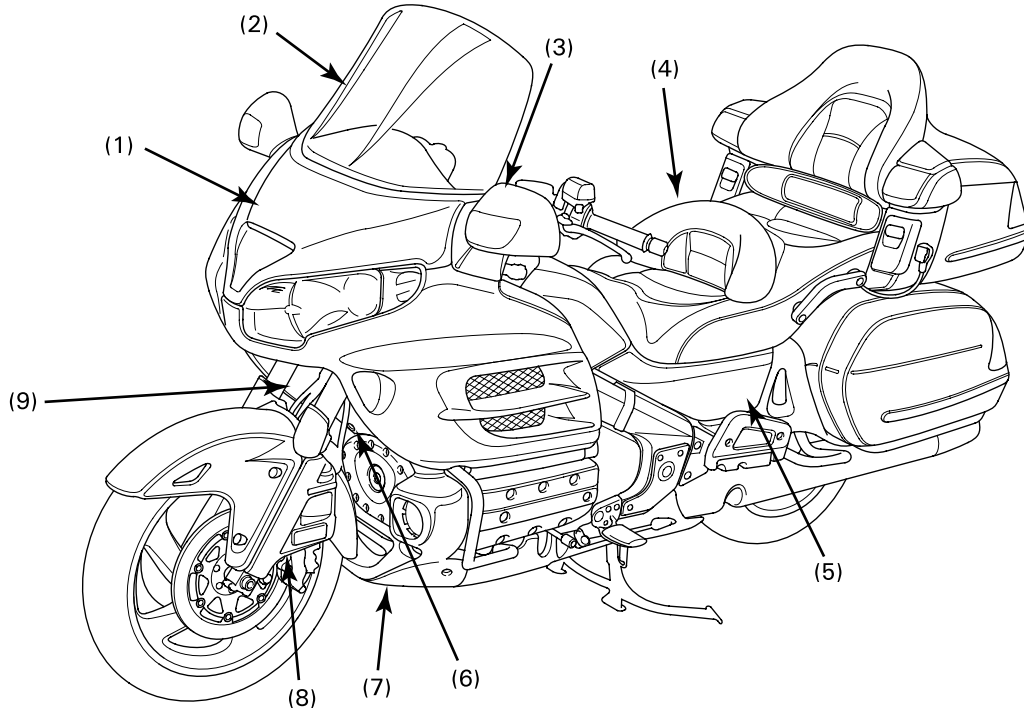

- (1) WINDSHIELD GARNISH (page 2-8)
- (2) WINDSHIELD (page 2-8)
- (3) REARVIEW MIRROR (page 2-7)
- (4) SEAT (page 2-5)
- (5) SIDE COVER (page 2-5)
- (6) CENTER INNER FAIRING (page 2-10)
- (7) FRONT LOWER FAIRING (page 2-6)
- (8) FRONT FENDER COVER (page 2-6)
- (9) INNER FAIRING (page 2-10)

- (10) TRUNK (page 2-13)
- (11) TOP SHELTER (page 2-11)
- (12) METER PANEL (page 2-7)
- (13) FRONT FAIRING (page 2-10)
- (14) ENGINE SIDE COVER (page 2-5)
- (15) SADDLEBAG (page 2-15)
- (16) TRUNK LOWER COVER (page 2-13)
- (17) REAR FENDER A (page 2-13)

# FRAME/BODY PANELS/EXHAUST SYSTEM

## BODY PANEL REMOVAL CHART

The following chart shows the removal order for the body components.

### FRONT FAIRING

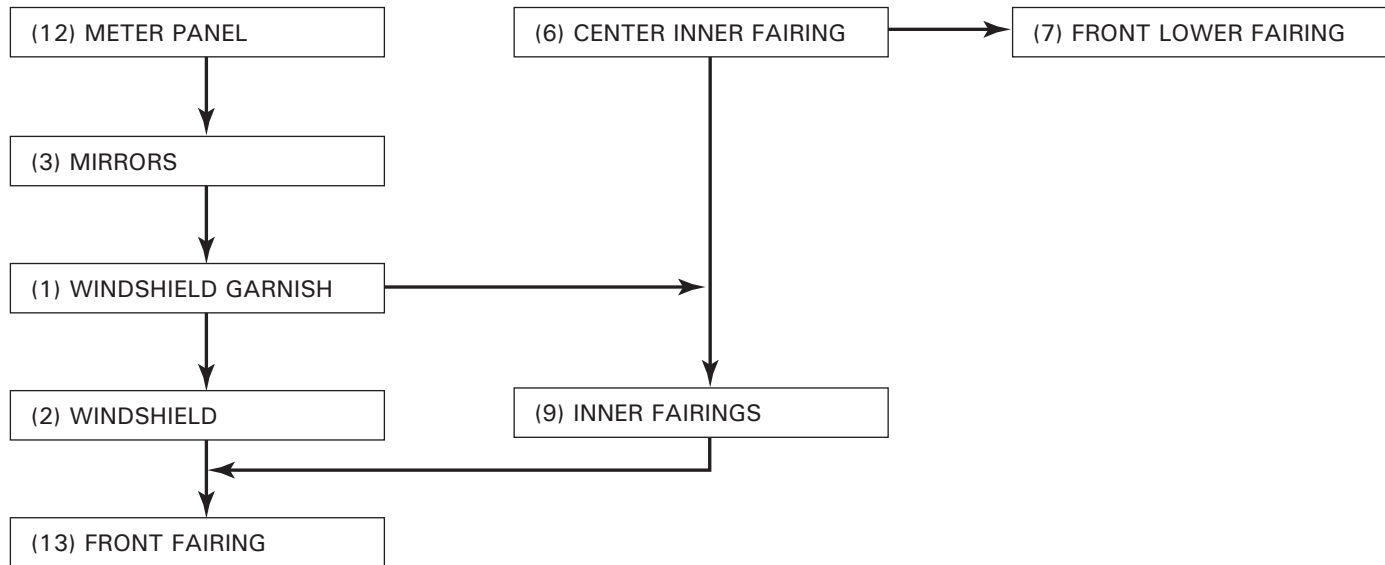

### TOP SHELTER

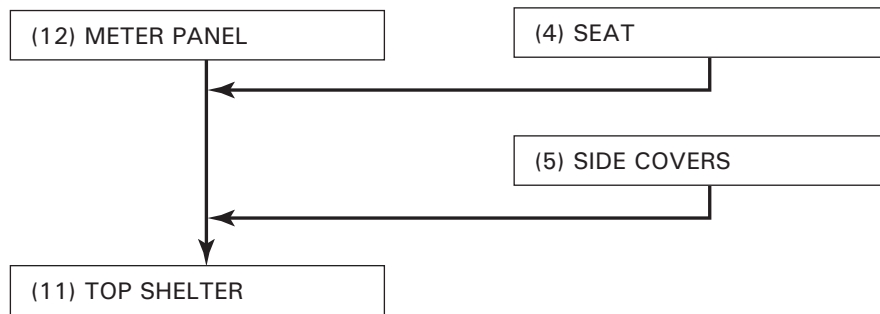

### TRUNK/SADDLEBAG

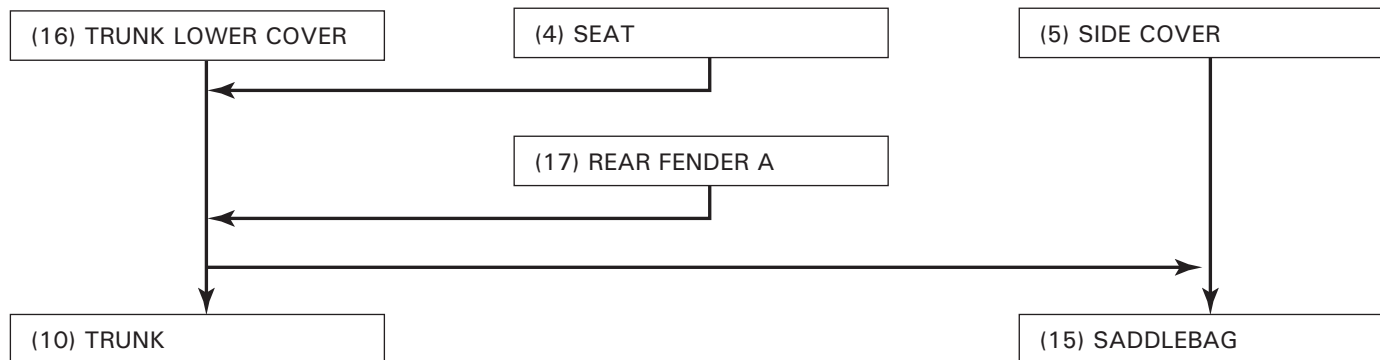

## SIDE COVER

Remove the side cover by releasing the four bosses from the grommets.

*Be careful not to dislodge the grommets.* Install the side cover in the reverse order of removal.

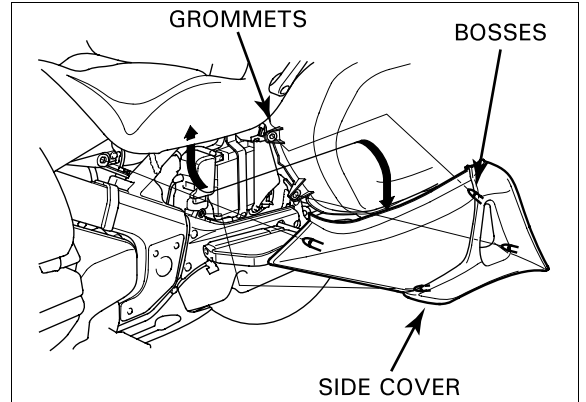

## ENGINE SIDE COVER

Release the two bosses from the grommets, free the front portion from the tab of the injector cover and remove the engine side cover.

*Apply soapy water to the tab for easy installation. Be careful not to dislodge the grommets.* Install the engine side cover from the lower side while aligning the slot with the tab of the injector cover, and insert the bosses into the grommets properly.

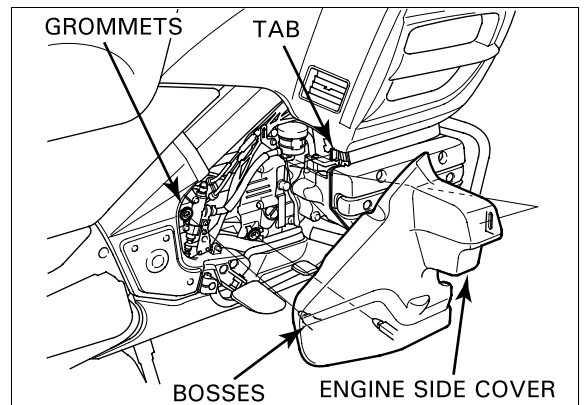

## SEAT

Remove the four bolts and passenger grips. Raise the rear of the seat and remove the seat by sliding it rearward.

Install the seat while inserting the tabs under the top shelter, and the prong under the shelter setting stay. Push down the rear of the seat, install the passenger grips and tighten the four bolts securely.

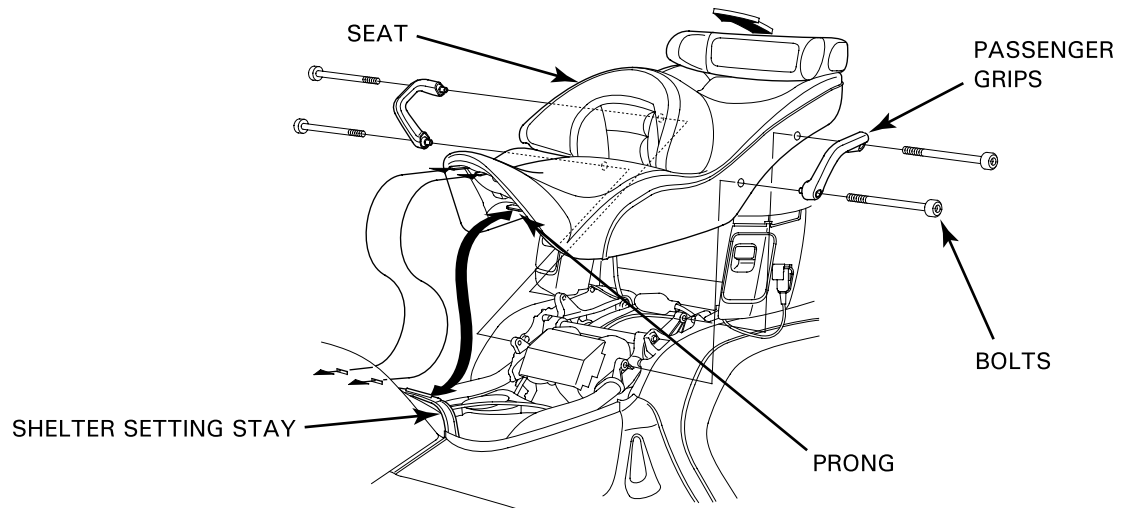

**FRONT FENDER COVERS**

Remove the four setting bolts, two rubber washers and front fender A.

Remove the four setting bolts and the front fender covers.

Installation is in the reverse order of removal.

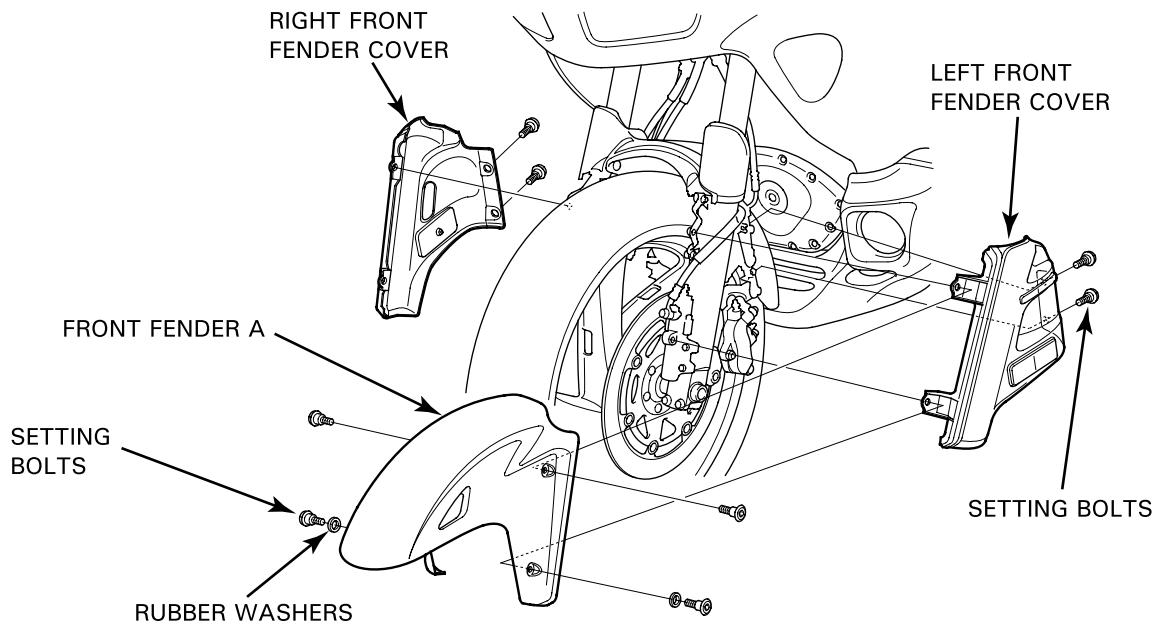

**FRONT LOWER FAIRING**

**CENTER INNER FAIRING**

Remove the six trim clips, two setting bolts and center inner fairing.

Install the center inner fairing, align the trim clip and bolt holes, and install the six trim clips and two setting bolts.

**FRONT LOWER FAIRING**

Remove the center inner fairing. Remove the four setting bolts and front lower fairing.

Installation is in the reverse order of removal.

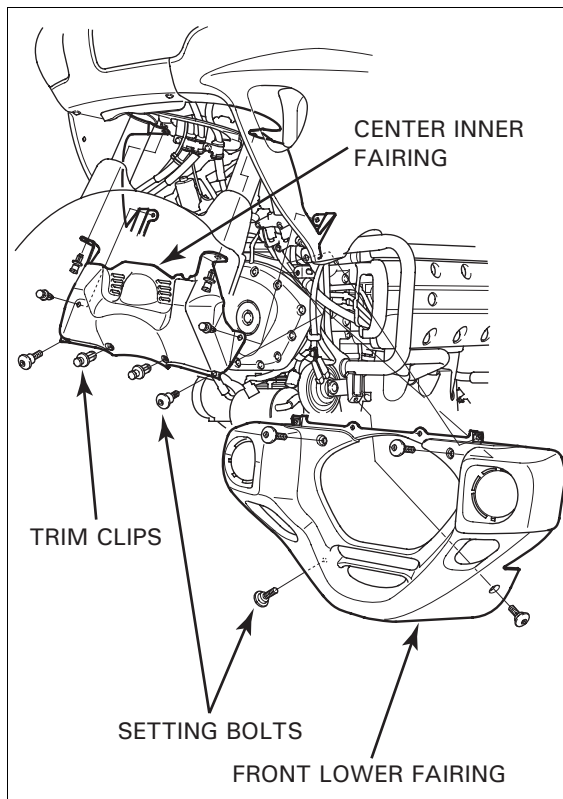

## METER PANEL

Remove the speaker covers by releasing the four tabs for each cover.

Remove the two trim clips and setting bolts.

Release the four bosses from the grommets, disconnect the multi-display control switch 4P connector and remove the meter panel.

Install the meter panel by aligning the four pins with the holes and the two tabs with the slots.

*Be careful not to dislodge the grommets.* Install the removed parts in the reverse order of removal.

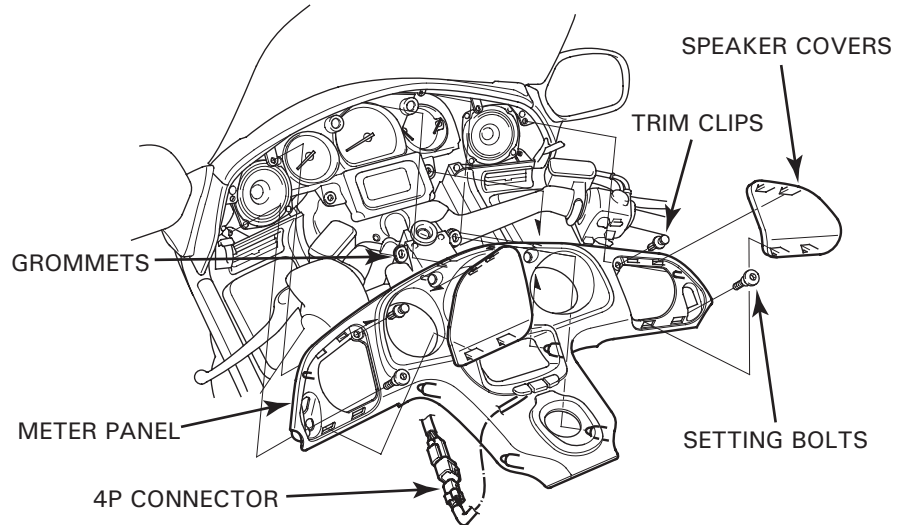

## REARVIEW MIRROR

Remove the meter panel.

Remove the mirror boot from the front fairing.

Remove the trim clip, screw and mirror cover.

Remove the three screws, bracket and mirror.

Disconnect the turn signal light 3P connector.

*Install the tabs and hooks of the windshield height lever boot and mirror boot properly.* Install the rearview mirror in the reverse order of removal.

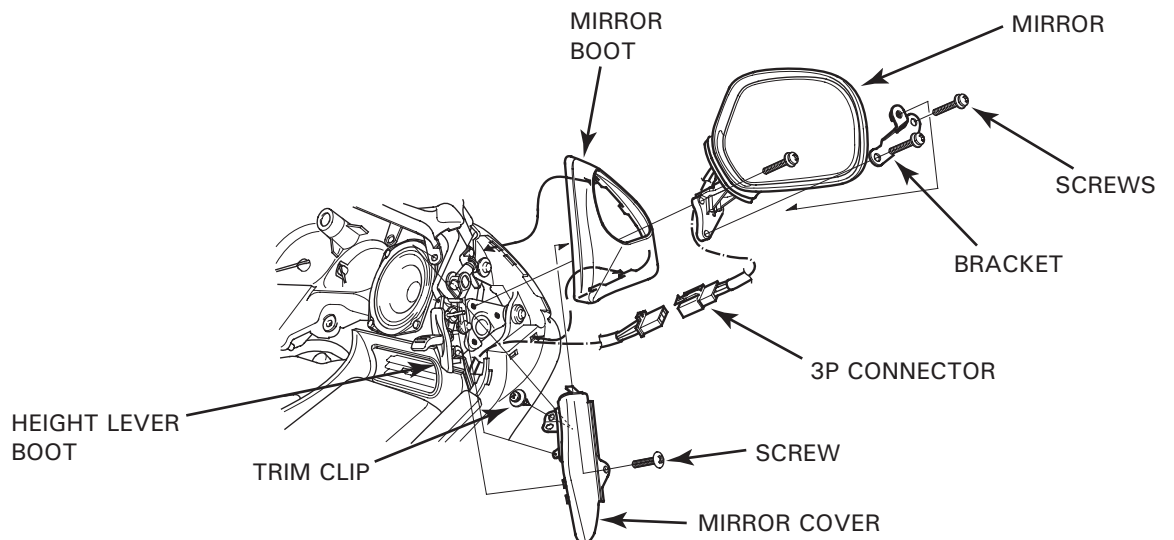



**WINDSHIELD**

**WINDSHIELD GARNISH**

Remove the left and right rearview mirrors (page 2-7).

Remove the two bolts, washers and mounting rubbers.

Release the four bosses from the grommets and remove the windshield garnish.

*Be careful not to dislodge the grommets.*

Installation is in the reverse order of removal.

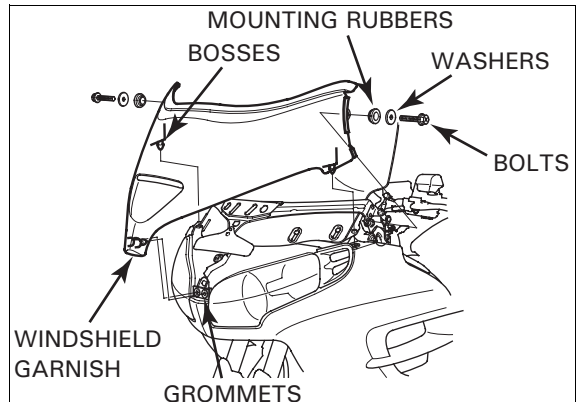

**WINDSHIELD**

Remove the windshield garnish.

Remove the bolt, two nuts and windshield holder plate.

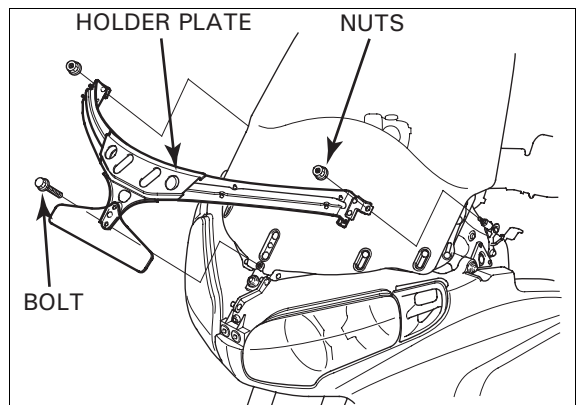

Make sure the windshield garnish locating tabs are hooked under the fairing tabs.

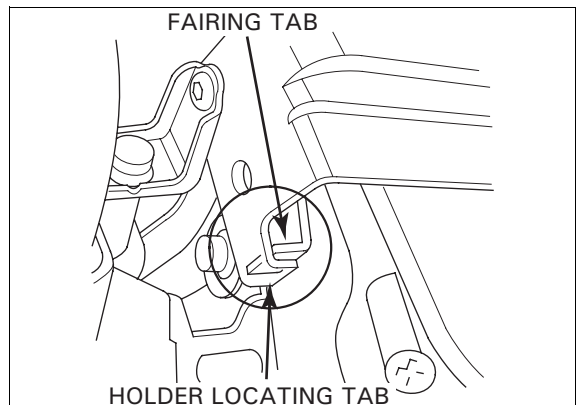

'01, '02: Remove the four setting screws.  
After '02: Remove the two setting screws.  
Remove the two setting bolts and windshield.  
Installation is in the reverse order of removal.

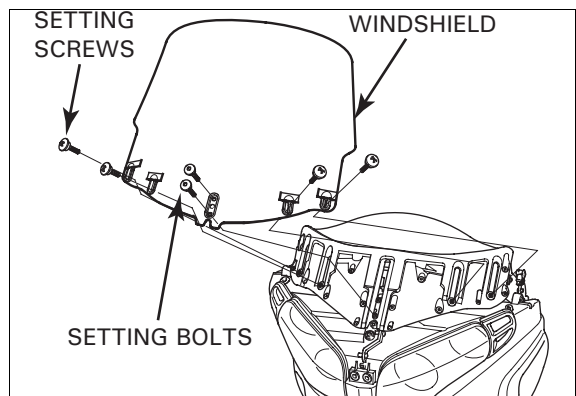

**CENTER FRESH AIR VISOR**

Remove the following from the windshield:

- two socket bolts
- two cap nuts
- four thrust washers
- center fresh air grille by releasing the tab.
- center fresh air visor
- two grommets

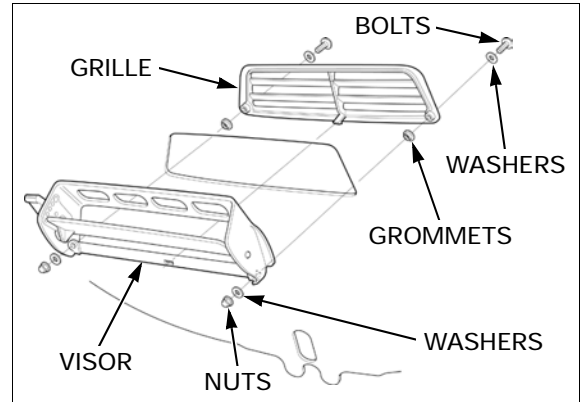

Remove the following from the air visor:

- cover plate
- screw
- lever cover
- lever
- steel ball
- spring
- lever click plate
- center fresh air lid

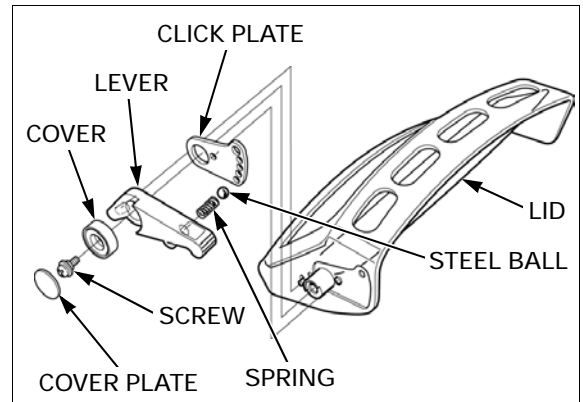

Install the lid on the visor.  
 Install the click plate by aligning the hole with the boss on the visor.  
 Install the spring and steel ball into hole in the lever.  
 Install the lever onto pivot of the visor while aligning the slot with the pin of the lid.  
 Install the lever cover and screw.

**TORQUE: 4 N·m (0.4 kgf·m, 2.9 lbf·ft)**

Install the cover plate onto the lever cover.

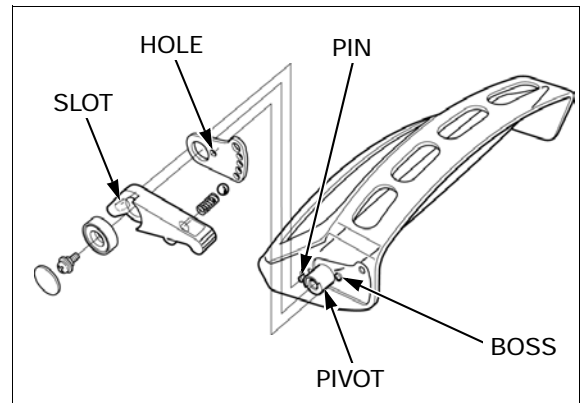

Install the grommets into the holes in the visor.  
 Install the grille and visor onto the windshield by aligning the tab with the slot.  
 Install the four washers, two socket bolts and cap nuts, and tighten the bolts.

**TORQUE: 1 N·m (0.1 kgf·m, 0.7 lbf·ft)**

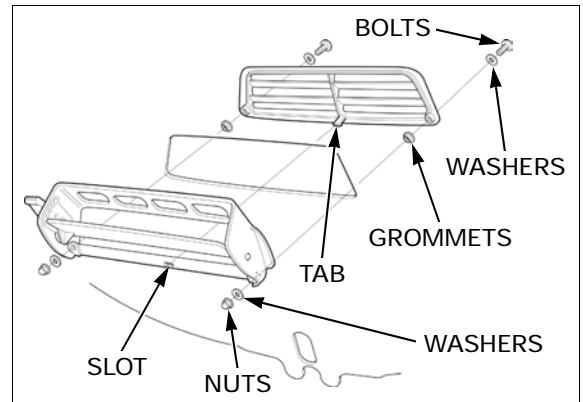

### INNER FAIRING

Remove the following:

- center inner fairing (page 2-10)
- windshield garnish (page 2-8)

Remove the setting bolt, two setting screws and front fairing garnish.

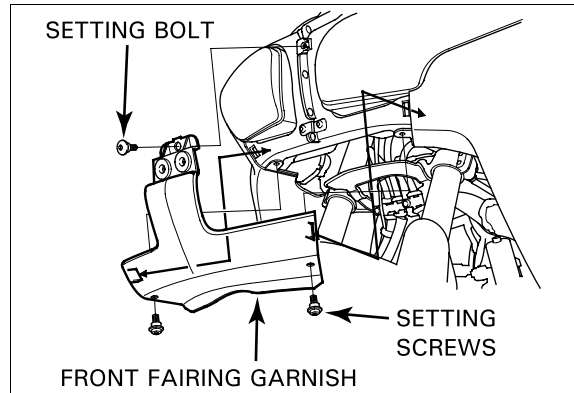

Remove the screw, three trim clips and inner fairing. Install the inner fairing, align the trim clip holes, and install the three trim clips and screw.

Install the removed parts in the reverse order of removal.

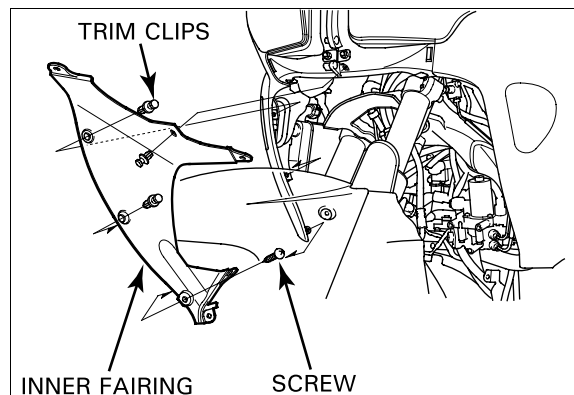

### FRONT FAIRING

#### FAIRING MOLDING

Carefully release the front tab first, then release the other tabs and remove the fairing molding.

Install the fairing molding in the reverse order of removal, being careful not to damage the tabs.

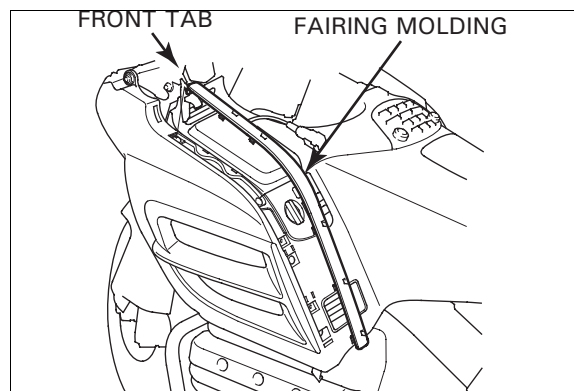

#### FRONT FAIRING

Remove the following:

- left and right fairing molding
- windshield (page 2-8)
- left and right inner fairings

Remove the two trim clips, six 6 x 11 mm bolts, two 6 x 14 mm setting bolts, four 5 x 12 mm screws, and meter panel visor.

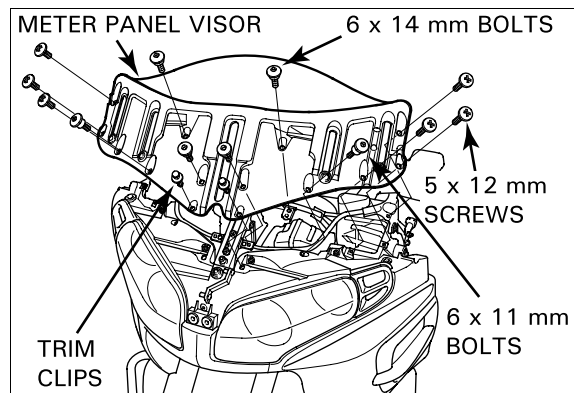

Disconnect the six headlight connectors.  
Remove the two 5 x 19 mm, four 5 x 12 mm and two 6 mm setting bolts.  
Remove the three flange bolts and collars and move the front fairing forward.  
Disconnect the bank angle sensor and open air temperature sensor connectors, and remove the front fairing.

Temporarily install the front fairing, and connect the bank angle sensor and open air temperature sensor connectors.  
Install the front fairing while inserting the two bosses into the grommets.  
Install the removed parts in the reverse order of removal.

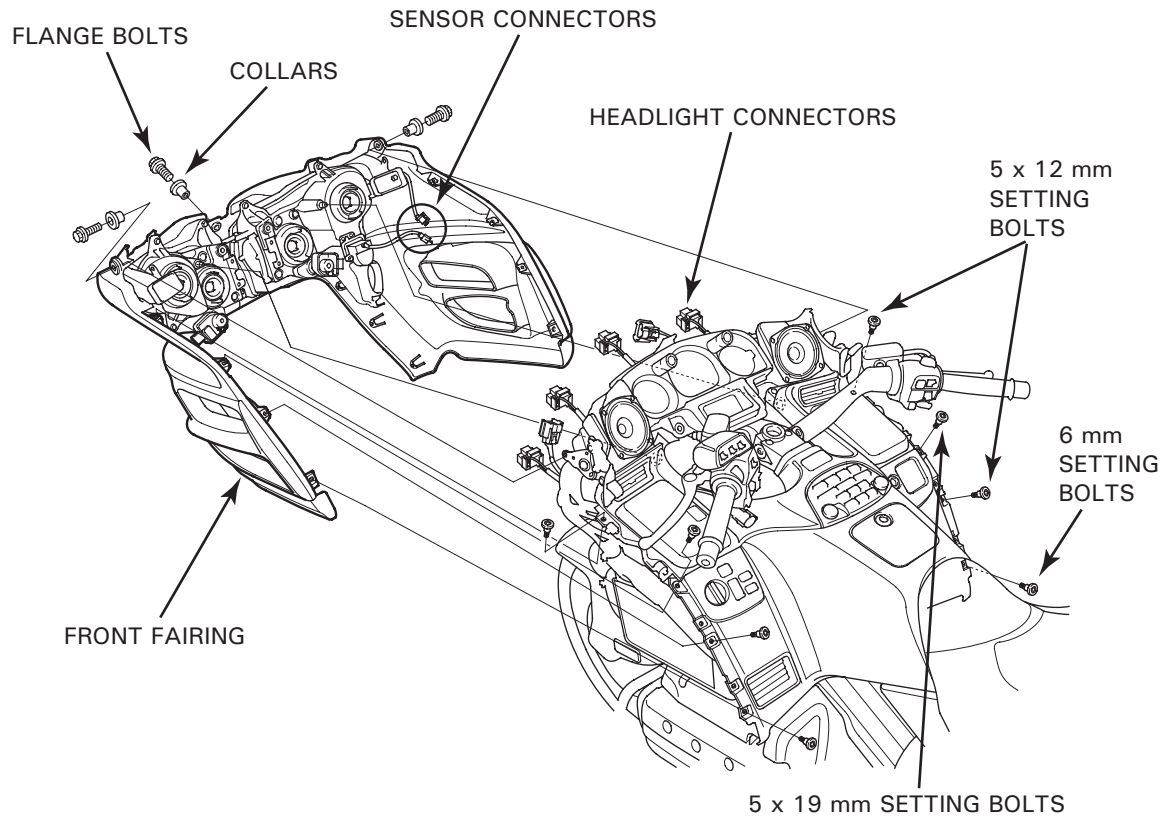

## TOP SHELTER

### FAIRING POCKET

#### LEFT FAIRING POCKET

Push the opener button and open the fairing pocket lid.

Remove the four trim clips by pushing the center pins in, and remove the fairing pocket.

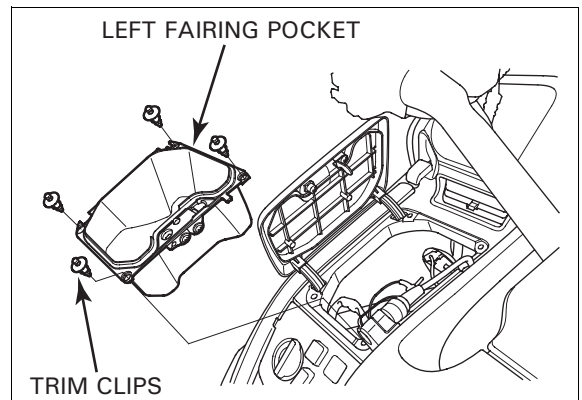

## FRAME/BODY PANELS/EXHAUST SYSTEM

### RIGHT FAIRING POCKET

Insert the ignition key into the lock cylinder and open the fairing pocket lid by turning the key clockwise.

Remove the four trim clips by pushing the center pins in.

Disconnect the opener cable and remove the right fairing pocket.

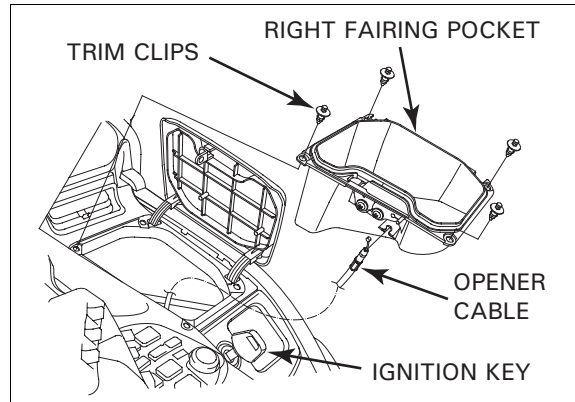

### TOP SHELTER

Remove the following:

- left and right fairing pockets
- meter panel (page 2-7)
- left and right fairing molding (page 2-10)
- seat (page 2-5)
- left and right side covers (page 2-5)

Remove the headset connector from the holder.

Remove the two 5 x 18 mm, four 5 x 12 mm, two 5 x 19 mm and four 6 mm setting bolts.

Remove the two nuts and remove the rear ends of the top shelter from the studs.

Disconnect the left panel switch assembly, antenna and audio unit connectors, and remove the top shelter.

Installation is in the reverse order of removal.

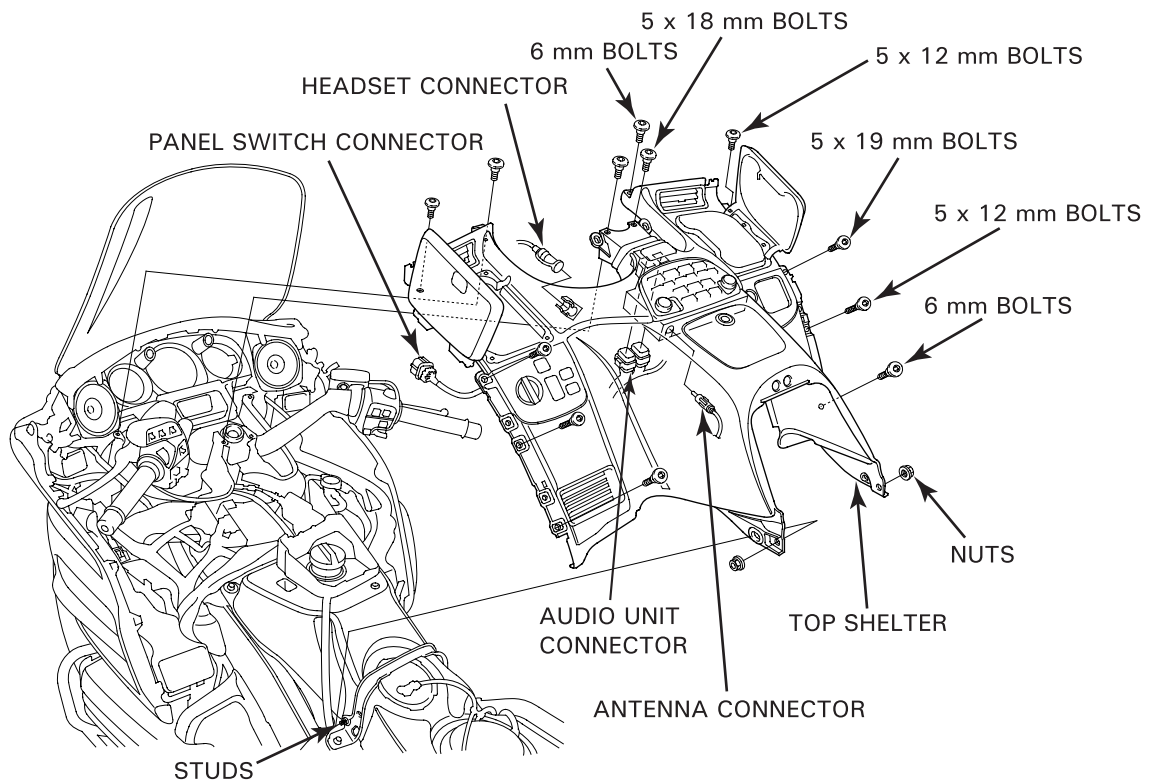

## REAR FENDER A

Remove the flange bolt and four setting bolts.  
Release the tabs from the saddlebags, being careful not to damage them and remove rear fender A.

Install rear fender A cover in the reverse order of removal.

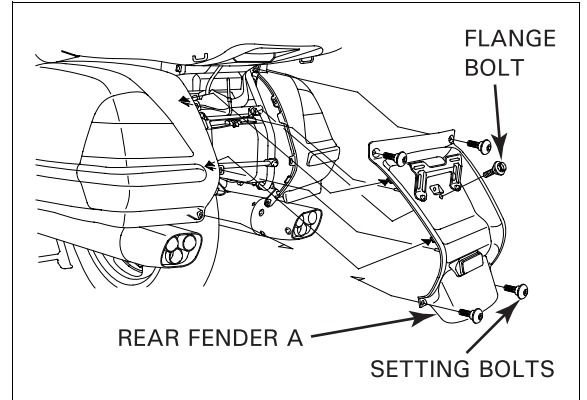

## TRUNK LOWER COVER

Open the trunk lid.

Remove the four self-tapping screws and trunk side moldings.

Remove the two self-tapping screws and trunk center molding.

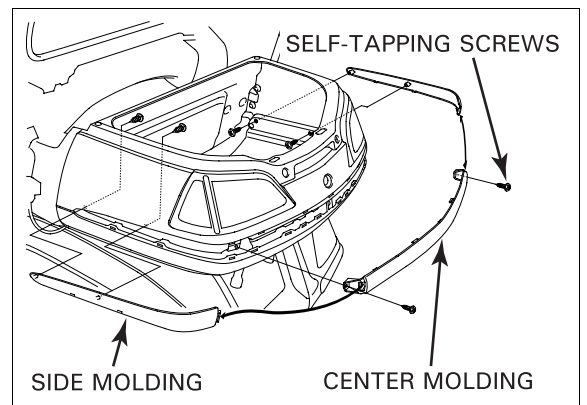

Remove the seven self-tapping screws.  
Release the four screw studs from the trunk by lightly pulling the trunk lower cover outward, and remove the cover.

Installation is in the reverse order of removal.

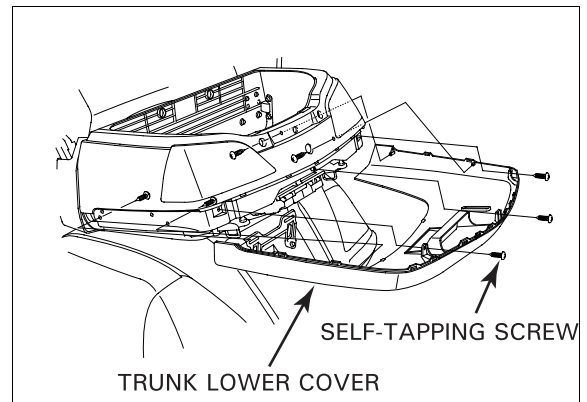

## TRUNK

### TRUNK LID

Remove the seat (page 2-5).

Open the trunk lid.

Disconnect the 12P connector of the trunk control unit sub-wire harness and remove the sub-wire harness from the wire band and clamps.

Remove the six mounting bolts and trunk lid.

Install the trunk lid in the reverse order of removal.

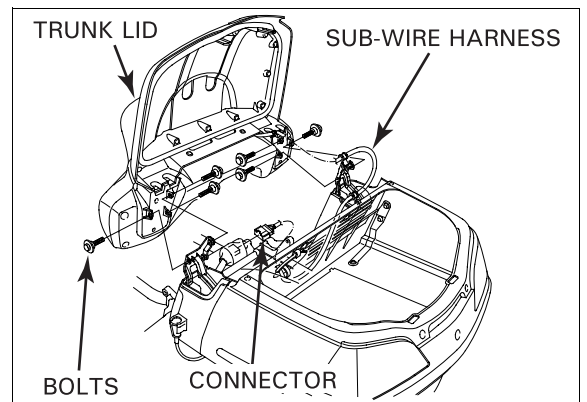

## FRAME/BODY PANELS/EXHAUST SYSTEM

### TRUNK LOCK COVER

Open the trunk lid.  
Remove the two self-tapping screws, three screws and trunk lock cover.

Install the trunk lock cover in the reverse order of removal.

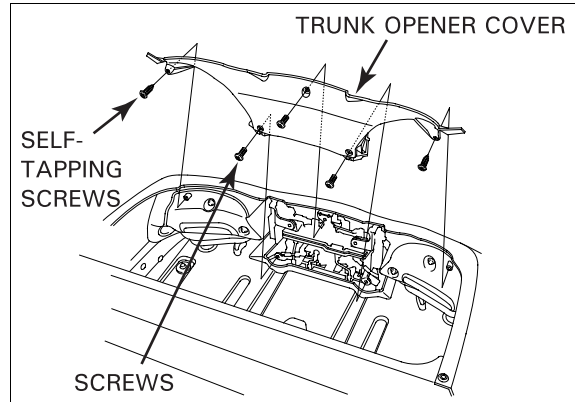

### TRUNK

Remove the following:

- seat (page 2-5)
- rear fender A (page 2-13)
- trunk lower cover (page 2-13)
- trunk lock cover
- passenger headset connector from the holder

Disconnect the saddlebag opener cables and sub-wire harness connectors and license light connector.

Disconnect the antenna connector and 12P connector of the trunk control unit sub-wire harness and 14P connector of the trunk sub-wire harness.

Remove the wire bands.

Remove the four mounting bolts, three washers and trunk assembly from the stay.

Installation is in the reverse order of removal.

*Route the wires and cables properly (page 1-23).*

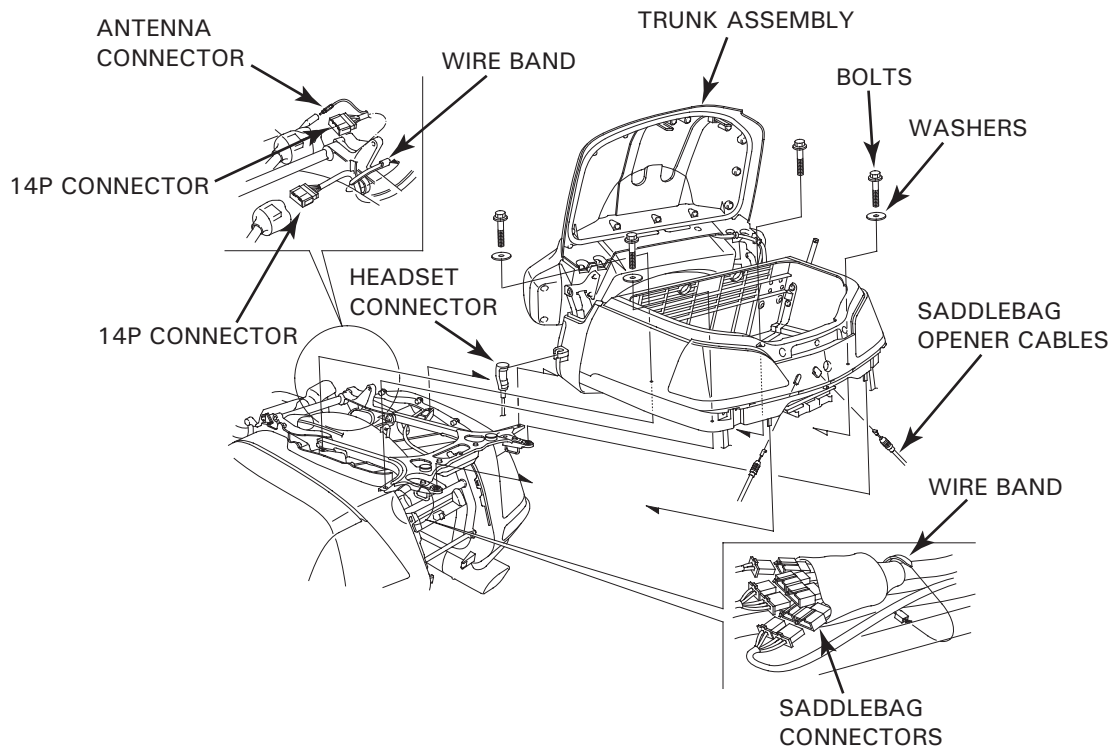



## SADDLEBAGS

Perform the following procedure for both the left and right saddlebags.

Remove the following:

- seat (page 2-5)
- left and right side covers (page 2-5)
- rear fender A (page 2-13)
- trunk lower cover (page 2-13)
- trunk lock cover (page 2-13)

Disconnect the saddlebag opener cable and sub-wire harness connectors.

Remove the four bolts, washer and the saddlebag.

Remove the four collars from the saddle bag.

*Route the wires and cables properly (page 1-23).*

Installation is in the reverse order of removal.

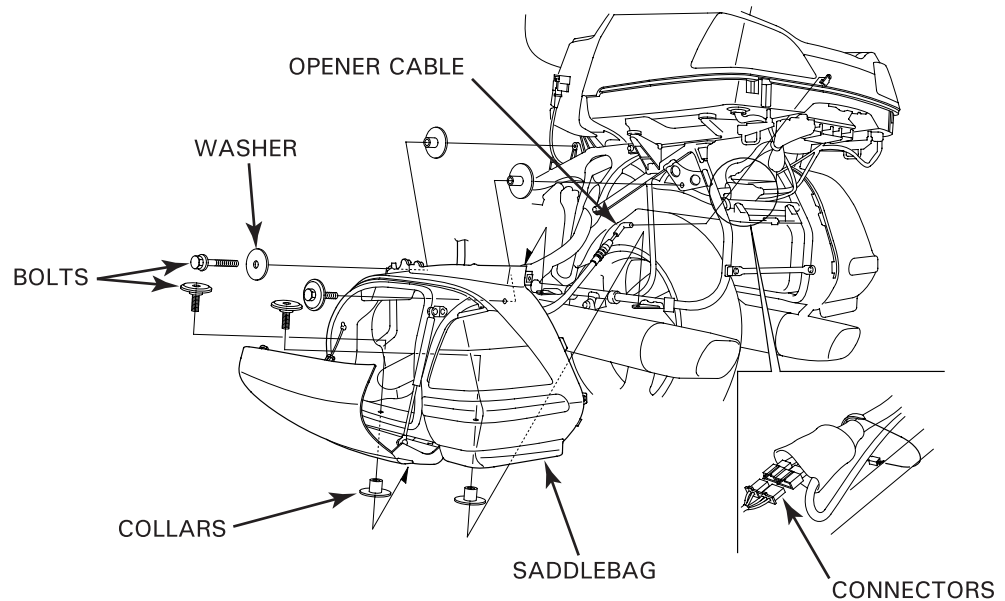

## SADDLEBAG CATCH

Perform the following procedure for both the left and right saddlebags.

Remove the saddlebag.

Remove the ten screws and inner cover.

Disconnect the saddlebag open switch connector and remove the saddlebag catch assembly.

*The saddlebag catches are located on the inside top of the saddlebags.*

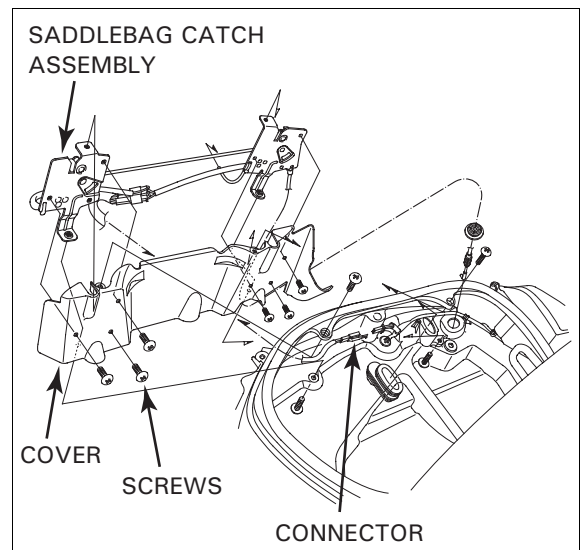



### REAR FENDER B

Remove the left and right saddlebags (page 2-15).

Remove the following from the rear fender:

- two screws and relay box assembly
- starter relay switches A and B
- power control relays 1 and 2
- speed limiter relay
- reverse regulator assembly
- connector holder
- band and ABS control unit

Remove the four bolts, release the hooks and remove rear fender B.

Installation is in the reverse order of removal.

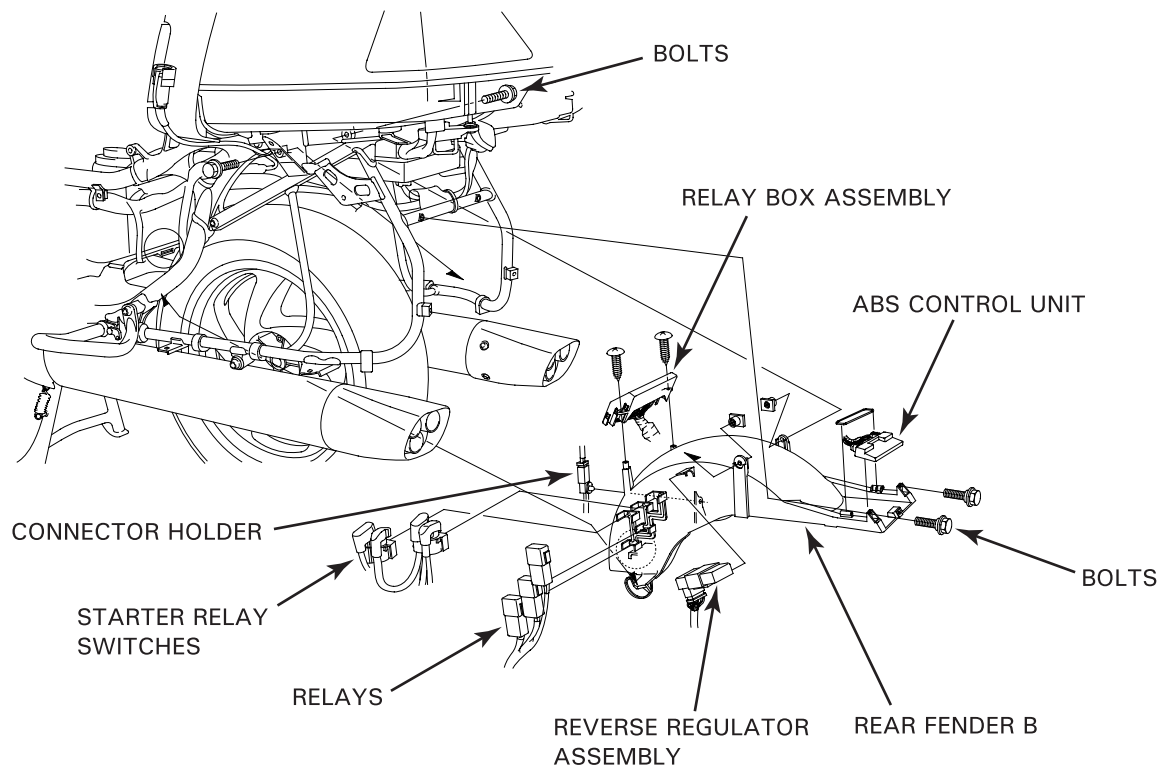

## SADDLEBAG/TRUNK STAY

### FOOTREST UNDER COVER

Remove the side cover (page 2-5).

Remove the three bolts and footrest under cover.

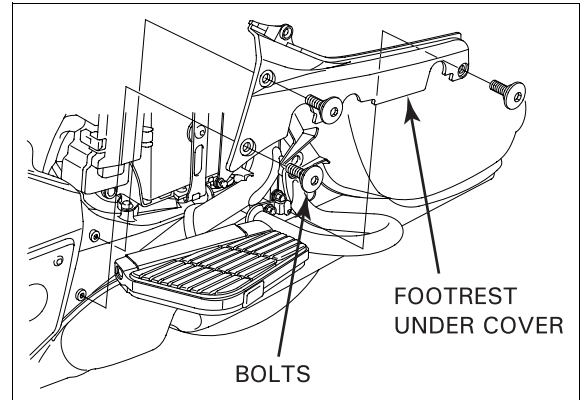

### SADDLEBAG/TRUNK STAY

Remove the following:

- left and right footrest under covers
- trunk (page 2-13)
- left and right saddlebags (page 2-15)
- four bolts and guard pipes
- two rear fender bolts

Remove the two nuts, six bolts and saddlebag/trunk stay.

Installation is in the reverse order of removal.

**TORQUE: Stay bolt: 26 N·m (2.7 kgf·m, 20 lbf·ft)**

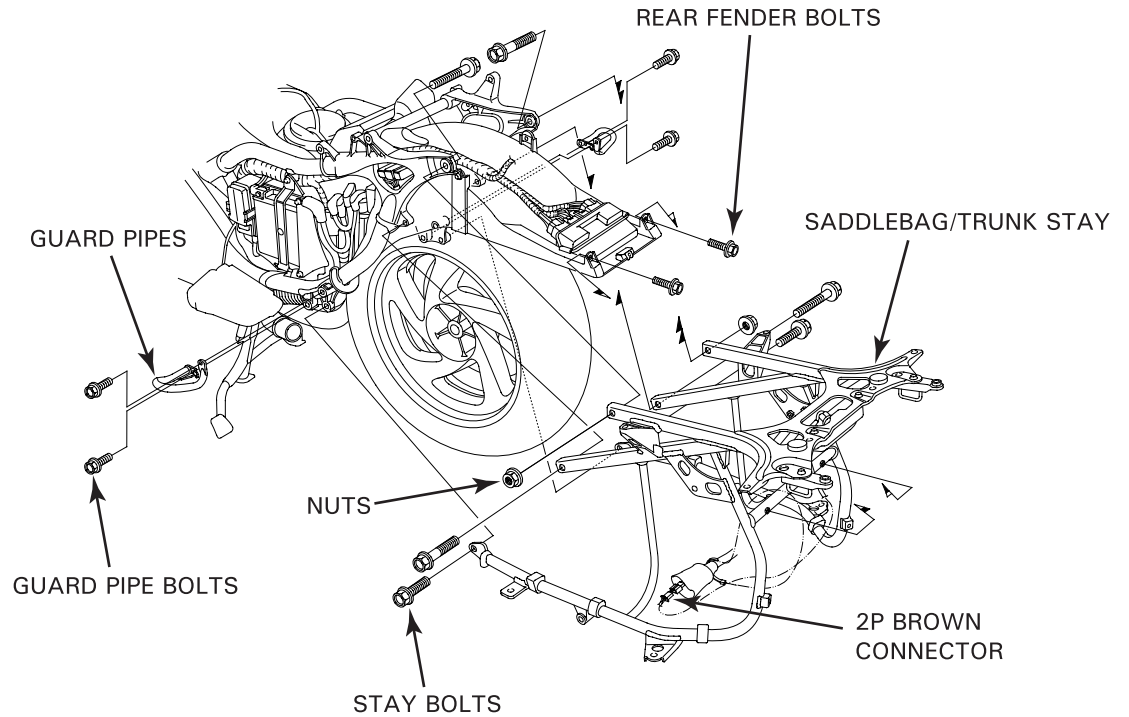

## EXHAUST SYSTEM

### FRONT EXHAUST PIPE PROTECTOR

Perform the following procedure for both the left and right exhaust pipe protectors.

Remove the following:

- front lower fairing (page 2-6)
- bolt, two nuts and four fiber washers

*Do not lose the hook rubbers on the tabs.*

Remove the lower portion of the protector from the studs, release the four hooks from the tabs and remove the protector.

*Replace the fiber washers with new ones.*

Installation is in the reverse order of removal.

**TORQUE: Bolt: 12 N·m (1.2 kgf·m, 9 lbf·ft)**

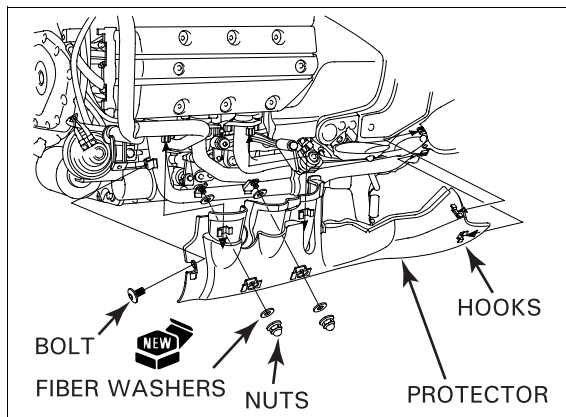

### MUFFLER/EXHAUST PIPE REMOVAL

The following instructions are for both the left and right sides.

Remove the following:

- left and right exhaust pipe protector
- top shelter (page 2-11)

Disconnect the left and right O<sub>2</sub> sensor connectors.

Disconnect the wire bands and lay the O<sub>2</sub> sensor leads aside. Remove the right O<sub>2</sub> sensor lead from the bracket and lay it aside.

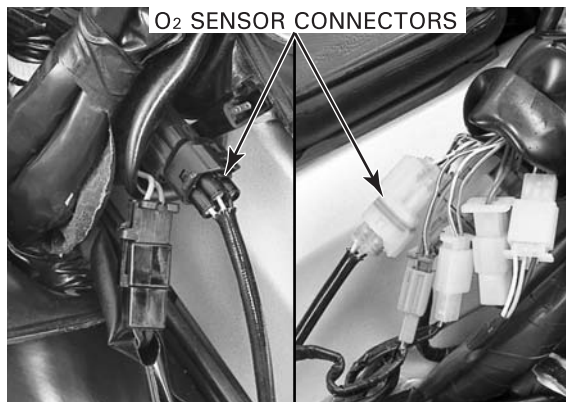

*Do not lose the hook rubbers on the tabs.*

Remove the bolt and rear exhaust pipe protector while releasing the two hooks from the tabs.

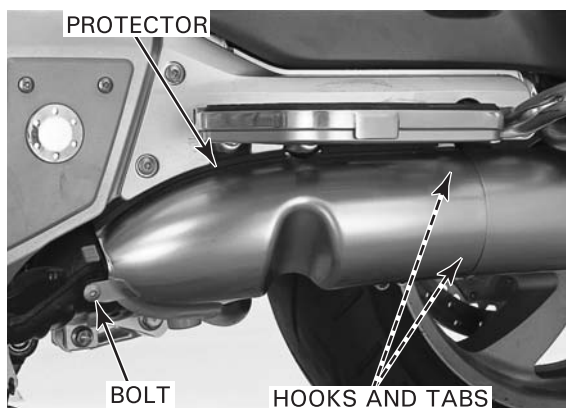

Loosen the muffler band bolts and slide the bands off the muffler flange, and onto the exhaust pipe.

Remove the mounting bolt, washer and muffler. Put on gloves, then remove the muffler gasket.

Remove the other side rear exhaust pipe protector and muffler.

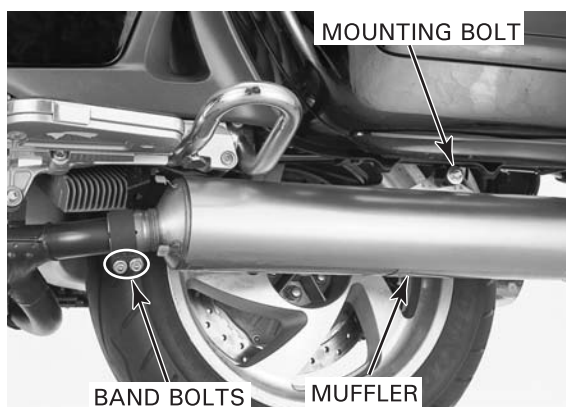

Loosen the exhaust pipe band bolts.

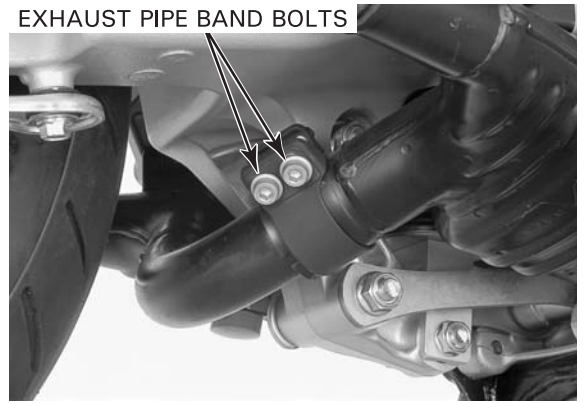

Remove both exhaust pipe joint nuts.

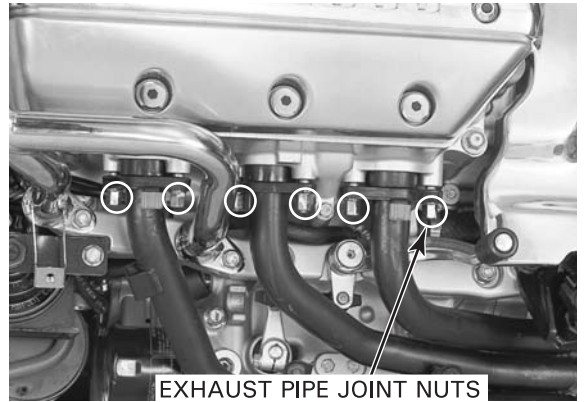

*Do not damage the O<sub>2</sub> sensors while removing the exhaust pipes.* Put on gloves, then remove both exhaust pipe mounting bolts, washers and exhaust pipes. Remove the exhaust pipe joint gaskets. Separate the exhaust pipes and remove the gasket.

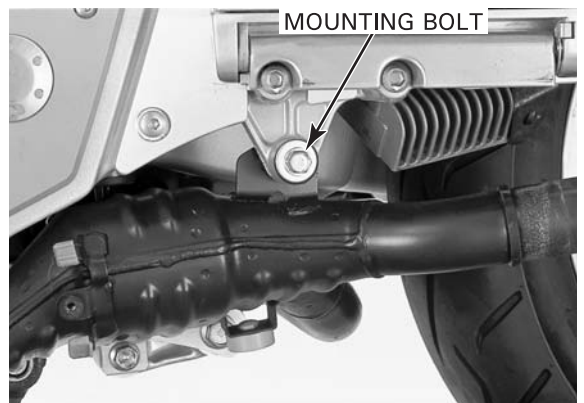

## FRAME/BODY PANELS/EXHAUST SYSTEM

### EXHAUST PIPE/MUFFLER INSTALLATION

Install both exhaust pipes with new gaskets.  
Loosely tighten all nuts and bolts.

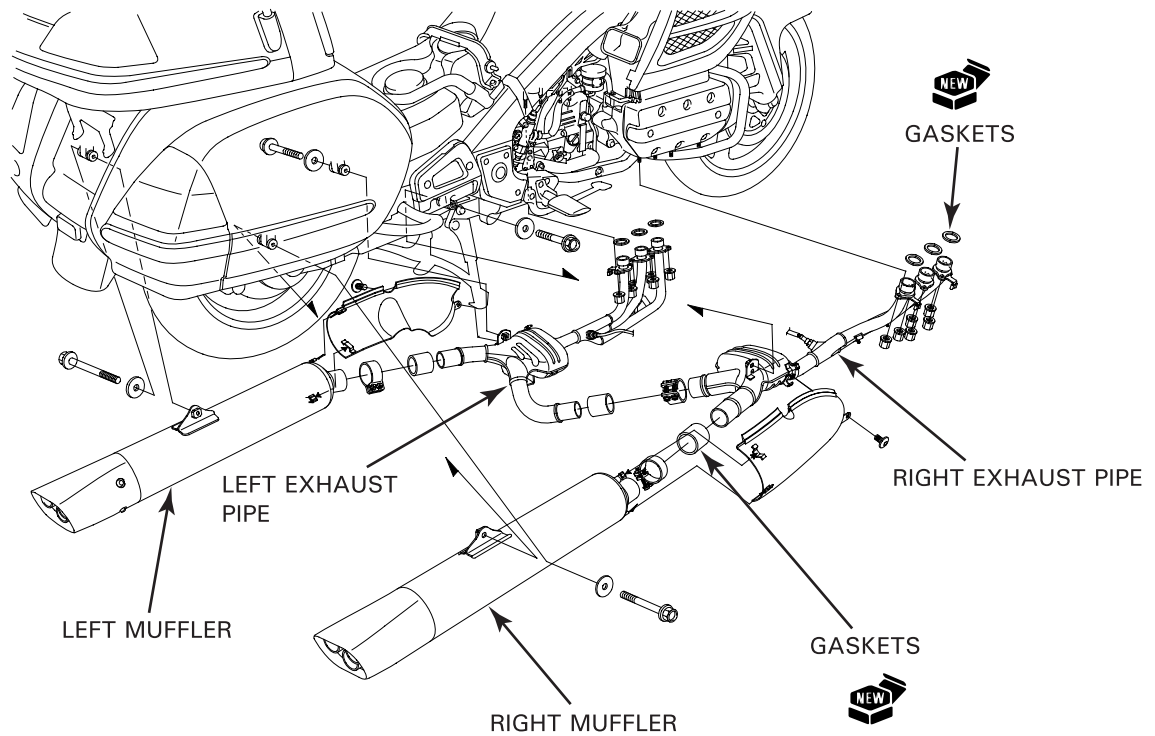

Tighten the exhaust pipe band bolts.

**TORQUE: 26 N·m (2.7 kgf·m, 20 lbf·ft)**

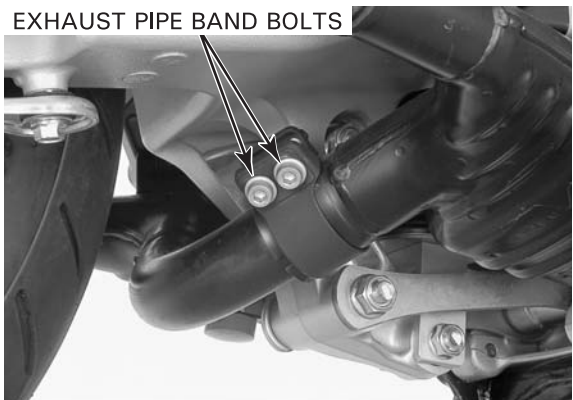

Tighten the exhaust pipe joint nuts.

**TORQUE: 12 N·m (1.2 kgf·m, 9 lbf·ft)**

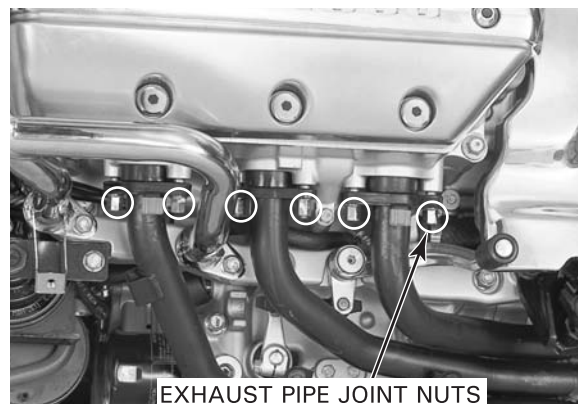

Tighten the exhaust pipe mounting bolts.

**TORQUE: 26 N·m (2.7 kgf·m, 20 lbf·ft)**

Install the mufflers with new gaskets.

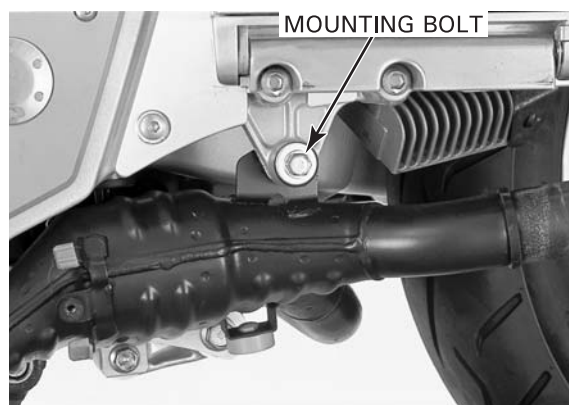

Tighten the muffler band bolts.

**TORQUE: 26 N·m (2.7 kgf·m, 20 lbf·ft)**

Tighten the muffler mounting bolts.

Install the removed parts in the reverse order of removal.

**TORQUE: Rear exhaust pipe protector bolt:  
14 N·m (1.4 kgf·m, 10 lbf·ft)**

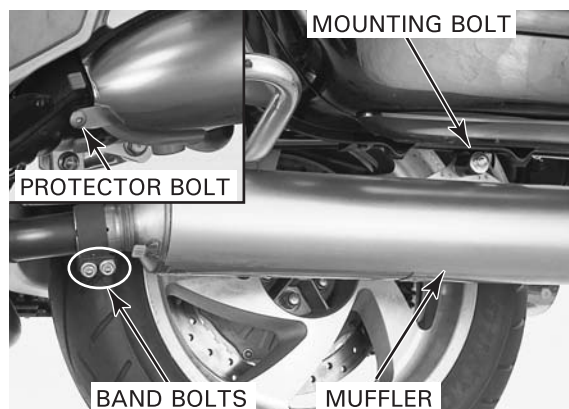

---

**MEMO**

---

SERVICE INFORMATION .....	3-2	FINAL DRIVE OIL .....	3-15
MAINTENANCE SCHEDULE .....	3-4	BRAKE FLUID.....	3-16
FUEL LINE .....	3-5	BRAKE PAD WEAR.....	3-17
THROTTLE OPERATION.....	3-5	BRAKE SYSTEM.....	3-18
AIR CLEANER.....	3-6	BRAKE LIGHT SWITCH .....	3-18
CRANKCASE BREATHER .....	3-7	HEADLIGHT AIM .....	3-19
SPARK PLUG .....	3-8	CLUTCH SYSTEM.....	3-19
VALVE CLEARANCE.....	3-9	CLUTCH FLUID .....	3-19
ENGINE OIL.....	3-11	REVERSE OPERATION.....	3-20
ENGINE OIL FILTER.....	3-12	SIDE STAND .....	3-20
RADIATOR COOLANT .....	3-13	SUSPENSION .....	3-21
COOLING SYSTEM.....	3-14	NUTS, BOLTS, FASTENERS.....	3-21
SECONDARY AIR SUPPLY SYSTEM.....	3-14	WHEELS/TIRES .....	3-22
EVAPORATIVE EMISSION CONTROL SYSTEM .....	3-15	STEERING HEAD BEARINGS .....	3-22



## MAINTENANCE

# SERVICE INFORMATION

## SPECIFICATIONS

ITEM		SPECIFICATIONS	
Throttle grip free play		2 – 6 mm (1/12 – 1/4 in)	
Spark plug	Standard	BKR6E-11 (NGK), K20PR-U11 (DENSO)	
	For cold climate (below 5°C/41°F)	BKR5E-11 (NGK), K16PR-U11 (DENSO)	
	For extended high speed riding	BKR7E-11 (NGK), K22PR-U11 (DENSO)	
Spark plug gap		1.00 – 1.10 mm (0.039 – 0.043 in)	
Valve clearance	Intake	0.15 ± 0.03 mm (0.006 ± 0.001 in)	
	Exhaust	0.22 ± 0.03 mm (0.009 ± 0.001 in)	
Recommended engine oil		Pro Honda GN4 or HP4 (without molybdenum additives) 4-stroke oil or equivalent motor oil API service classification: SG or higher JASO T 903 standard: MA Viscosity: SAE 10W-40	
Engine oil capacity	After draining	3.6 liters (3.8 US qt, 3.2 Imp qt)	
	After draining/filter change	3.7 liters (3.9 US qt, 3.3 Imp qt)	
	After disassembly	4.6 liters (4.9 US qt, 4.0 Imp qt)	
Final drive oil capacity	After draining	120 cm <sup>3</sup> (4.1 US oz, 4.2 Imp oz)	
	After disassembly	150 cm <sup>3</sup> (5.1 US oz, 5.3 Imp oz)	
Recommended brake fluid		DOT 4 brake fluid	
Recommended clutch fluid		DOT 4 brake fluid	
Cold tire pressure	Up to 90 kg (200 lbs) load	Front	250 kPa (2.50 kgf/cm <sup>2</sup> , 36 psi)
		Rear	280 kPa (2.80 kgf/cm <sup>2</sup> , 41 psi)
	Up to maximum weight capacity	Front	250 kPa (2.50 kgf/cm <sup>2</sup> , 36 psi)
		Rear	280 kPa (2.80 kgf/cm <sup>2</sup> , 41 psi)
Tire size	Front	130/70R18 (63H), 130/70R18M/C (63H)	
	Rear	180/60R16 (74H), 180/60R16M/C (74H)	
Tire brand	Front	D250F (Dunlop), G707 RADIAL (Bridgestone), G709 RADIAL (Bridgestone)	
	Rear	D250 (Dunlop), G704 RADIAL (Bridgestone)	
Minimum tread depth	Front	1.5 mm (0.06 in)	
	Rear	2.0 mm (0.08 in)	

## TORQUE VALUES

Cylinder head side cover bolt	10 N·m (1.0 kgf·m, 7 lbf·ft)	
Spark plug	18 N·m (1.8 kgf·m, 13 lbf·ft)	
Cylinder head cover bolt	12 N·m (1.2 kgf·m, 9 lbf·ft)	
Timing hole cap	18 N·m (1.8 kgf·m, 13 lbf·ft)	Apply grease to the threads.
Engine oil drain bolt	34 N·m (3.5 kgf·m, 25 lbf·ft)	
Engine oil filter cartridge	26 N·m (2.7 kgf·m, 20 lbf·ft)	Apply oil to the seal rubber and threads.
Final drive oil filler cap	12 N·m (1.2 kgf·m, 9 lbf·ft)	
Final drive oil drain bolt	20 N·m (2.0 kgf·m, 14 lbf·ft)	
Front brake reservoir cap screw	2 N·m (0.2 kgf·m, 1.4 lbf·ft)	
Clutch reservoir stopper plate screw	2 N·m (0.2 kgf·m, 1.4 lbf·ft)	

**TOOL**

Oil filter wrench  
07HAA-PJ70101

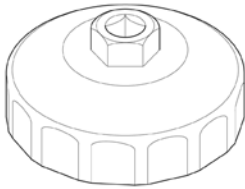

or 07HAA-PJ70100

## MAINTENANCE

# MAINTENANCE SCHEDULE

Perform the PRE-RIDE INSPECTION in the Owner's Manual at each scheduled maintenance period.

I: Inspect and clean, adjust, lubricate or replace if necessary. C: Clean. R: Replace. A: Adjust. L: Lubricate.

The following items require some mechanical knowledge. Certain items (particularly those marked \* and \*\*) may require more technical information and tools. Consult your Honda dealer.

ITEMS	FREQUENCY	NOTE ↓	ODOMETER READING (NOTE 1)							REFER TO PAGE	
			x 1,000 mi	4	8	12	16	20	24		
			x 1,000 km	6.4	12.8	19.2	25.6	32.0	38.4		
EMISSION RELATED ITEMS	*	FUEL LINE			I		I		I	3-5	
	*	THROTTLE OPERATION			I		I		I	3-5	
	*	AIR CLEANER	NOTE 2			R			R	3-6	
		CRANKCASE BREATHER	NOTE 3		C	C	C	C	C	3-7	
		SPARK PLUG		EVERY 16,000 mi (25,600 km) R							3-8
	*	VALVE CLEARANCE	NOTE 4	EVERY 32,000 mi (51,200 km) I							3-9
		ENGINE OIL		R		R		R		3-11	
		ENGINE OIL FILTER		R		R		R		3-12	
		RADIATOR COOLANT	NOTE 5		I		I		R	3-13	
	*	COOLING SYSTEM			I		I		I	3-14	
	*	SECONDARY AIR SUPPLY SYSTEM			I		I		I	3-14	
	*	EVAPORATIVE EMISSION CONTROL SYSTEM				I			I	3-15	
NON-EMISSION RELATED ITEMS		FINAL DRIVE OIL			I		I		R	3-15	
		BRAKE FLUID	NOTE 5	I	I	R	I	I	R	3-16	
		BRAKE PAD WEAR		I	I	I	I	I	I	3-17	
		BRAKE SYSTEM			I		I		I	3-18	
	*	BRAKE LIGHT SWITCH			I		I		I	3-18	
	*	HEADLIGHT AIM			I		I		I	3-19	
		CLUTCH SYSTEM			I		I		I	3-19	
		CLUTCH FLUID	NOTE 5	I	I	R	I	I	R	3-19	
	*	REVERSE OPERATION			I		I		I	3-20	
		SIDE STAND			I		I		I	3-20	
	*	SUSPENSION			I		I		I	3-21	
	*	NUTS, BOLTS, FASTENERS			I		I		I	3-21	
	**	WHEELS/TIRES			I		I		I	3-22	
**	STEERING HEAD BEARINGS			I		I		I	3-22		

\* Should be serviced by your dealer, unless the owner has proper tools and service data and is mechanically qualified.

\*\* In the interest of safety, we recommend these items be serviced only by your Honda dealer.

### NOTES:

- At higher odometer readings, repeat at the frequency interval established here.
- Service more frequently when riding in unusually wet or dusty areas.
- Service more frequently when riding in rain or at full throttle.
- Service more frequently if noisy.
- Replace every 2 years, or at the indicated odometer interval, whichever comes first. Replacement requires mechanical skill.

## FUEL LINE

Remove the air cleaner housing (page 5-57).  
 Check the fuel lines for deterioration, damage or leakage.  
 Replace the fuel lines if necessary.  
 Install the air cleaner housing (page 5-57).

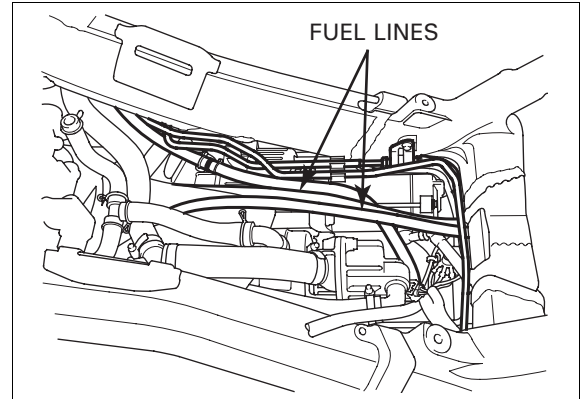

## THROTTLE OPERATION

Check for any deterioration or damage to the throttle cables. Check the throttle grip for smooth operation.  
 Check that the throttle opens and automatically closes in all steering positions.

If the throttle grip does not return properly, lubricate the throttle cables and overhaul and lubricate the throttle grip housing.

For cable lubrication, disconnect the throttle cables at their upper ends. Thoroughly lubricate the cables and their pivot points with a commercially available cable lubricant or a lightweight oil.

If the throttle grip still does not return properly, replace the throttle cables.

*Reusing a damaged or abnormally bent or kinked throttle cable can prevent proper throttle valve operation and may lead to a loss of throttle control while riding.*

With the engine idling, turn the handlebar all the way to the right and left to ensure that the idle speed does not change. If idle speed increases, check the throttle grip free play and the throttle cable connections.

Measure the throttle grip free play at the throttle grip flange.

**THROTTLE GRIP FREE PLAY: 2 – 6 mm (1/8 – 1/4 in)**

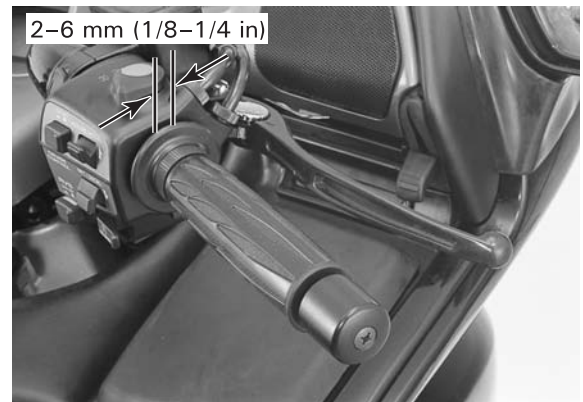

Minor adjustments are made with the upper adjuster.

Loosen the lock nut, turn the adjuster as required and tighten the lock nut.

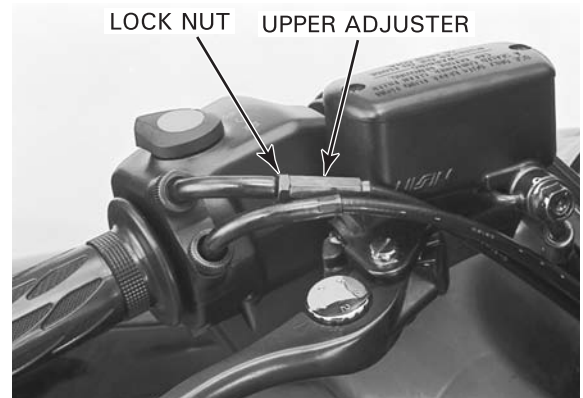

## MAINTENANCE

*The lower adjuster is located near the left frame rail/steering head area.*

Major adjustments are made with the lower adjusting nut.

Remove the top shelter (page 2-11).  
Loosen the lock nut, turn the adjusting nut as required and tighten the lock nut.

Recheck the throttle operation and install the top shelter (page 2-11).

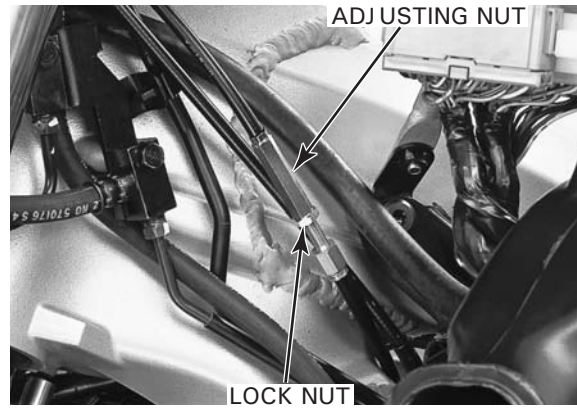

## AIR CLEANER

### NOTE:

- The viscous-paper-element-type air cleaner cannot be cleaned because the element contains a dust adhesive.
- If the motorcycle is used in unusually wet or dusty areas, more frequent inspections are required.

Remove the top shelter (page 2-11).

Remove the screws, right and left intake air ducts.

*Be sure that the duct rubbers fit onto the air cleaner cover securely.*



Disconnect the following:

- BARO sensor connector
- cruise control motor actuator connector
- cruise/reverse control module connectors
- engine control unit connectors

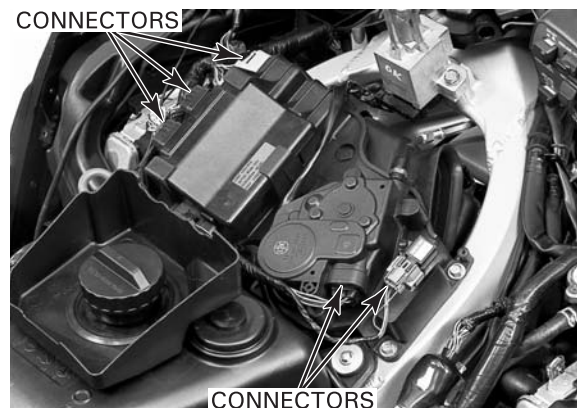

Remove the four bolts and control unit holder.

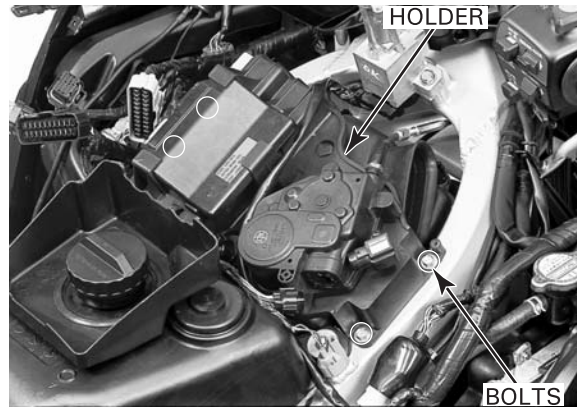

Disconnect the intake air temperature (IAT) sensor connector.  
Remove the seven screws and air cleaner cover.

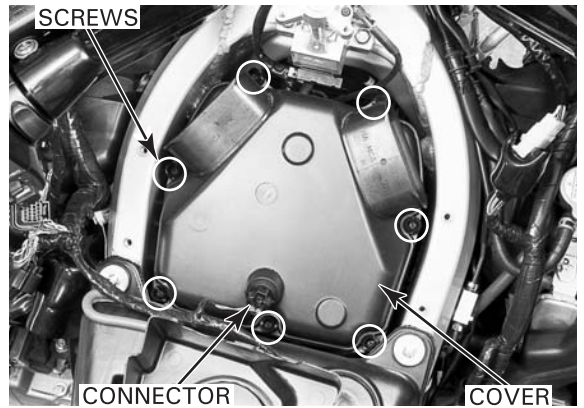

Replace the air cleaner element in accordance with the maintenance schedule or any time it is excessively dirty or damaged.

Install a new air cleaner element and the cover.

Install the removed parts in the reverse order of removal.



## CRANKCASE BREATHER

### NOTE:

- Service more frequently when ridden in rain, at full throttle, or after the motorcycle is washed or overturned. Service if the deposit level can be seen in the transparent section of the drain hose.

Remove the five rubber plugs, five socket bolts and left cylinder head side cover.





## MAINTENANCE

Remove the plug from the air cleaner housing drain hose and drain the deposits into a suitable container, then reinstall the plug securely.

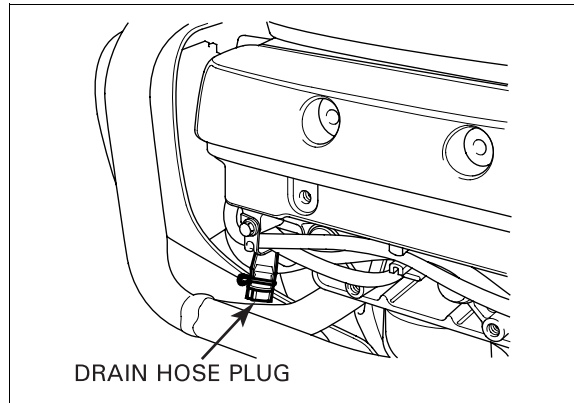

Install the left cylinder head side cover and tighten the socket bolts.

**TORQUE: 10 N·m (1.0 kgf·m, 7 lbf·ft)**

Install the rubber plugs.

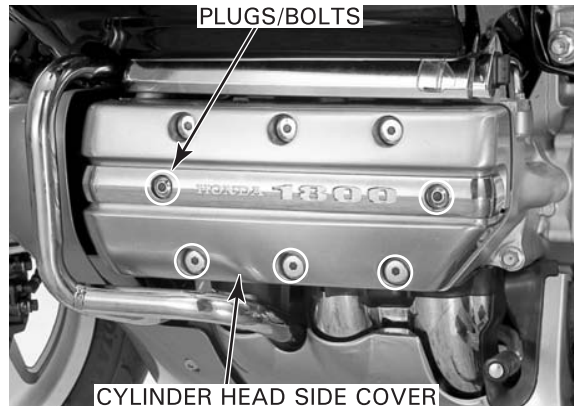

## SPARK PLUG

Remove the left and right cylinder head side covers (page 3-7).

Disconnect the spark plug caps and remove the spark plugs.

### RECOMMENDED SPARK PLUGS:

**Standard: BKR6E-11 (NGK), K20PR-U11 (DENSO)**

**For cold climate (below 5° C/41° F):**

**BKR5E-11 (NGK), K16PR-U11 (DENSO)**

**For expected high speed riding:**

**BKR7E-11 (NGK), K22PR-U11 (DENSO)**

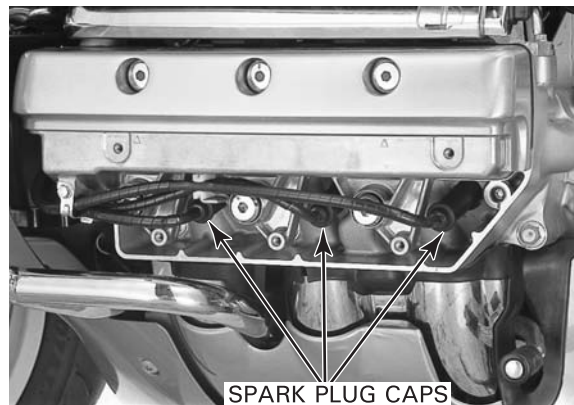

Measure the spark plug gap between the center and side electrodes with a wire-type feeler gauge.

**SPARK PLUG GAP: 1.0 – 1.1 mm (0.039 – 0.043 in)**

If necessary, adjust the gap by carefully bending the side electrode.

Thread each spark plug in by hand to prevent cross-threading and tighten them with a spark plug wrench.

**TORQUE: 18 N·m (1.8 kgf·m, 13 lbf·ft)**

Connect the spark plug caps.

Install the cylinder head side covers (page 3-7).

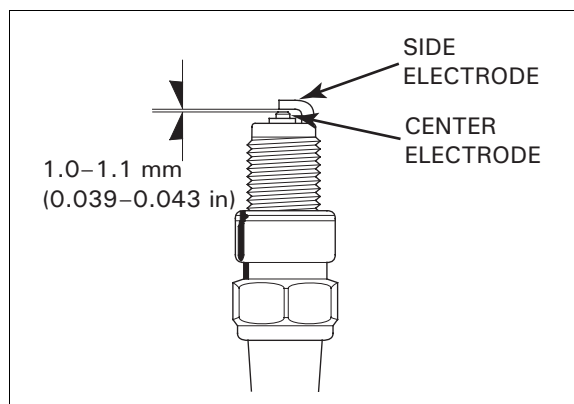

# VALVE CLEARANCE

## INSPECTION

**NOTE:**

- Inspect and adjust the valve clearance while the engine is cold (below 35° C, 95° F).

Remove the cylinder head side covers (page 3-7).

Remove the bolt and wire clamp, spark plug wires from the clip, and the three rubber plugs. Then remove the six socket bolts (left cylinder head cover), five socket bolts (right cylinder head cover), and cylinder head cover.

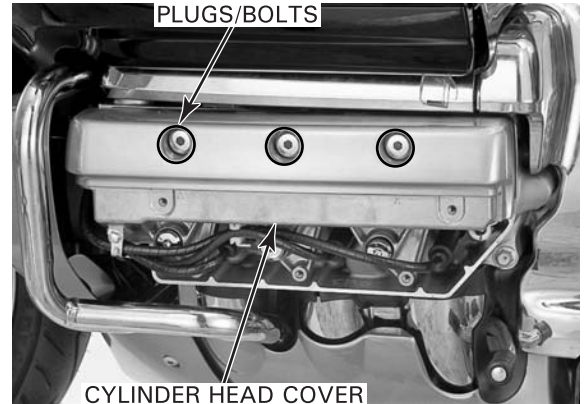

Remove the timing hole cap.

Loosen the cam chain tensioners (page 8-12).

*Failure to loosen the cam chain tensioners will result in inaccurate valve clearance measurement, due to the force of the cam chain on the camshaft.*

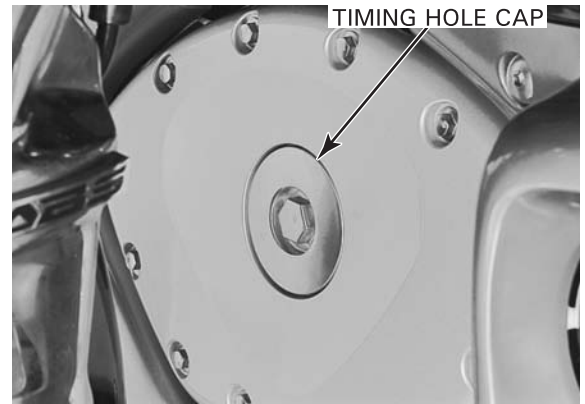

Rotate the crankshaft counterclockwise and align the T1.2 mark on the ignition pulse generator rotor with the index mark in the front crankcase cover. Make sure the No. 1 cylinder cam lobes are facing out. If they are facing in, rotate the crankshaft counterclockwise 360° (one full turn) and align the T1.2 mark with the index mark.

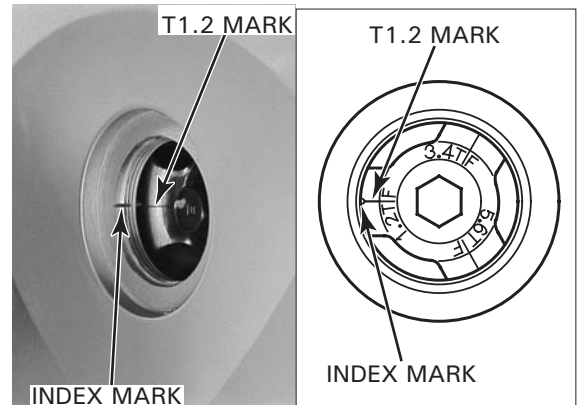

Measure the No. 1 cylinder valve clearance by inserting a feeler gauge between the valve lifter and cam lobe.

**VALVE CLEARANCES:**

**IN: 0.15 ± 0.03 mm (0.006 ± 0.001 in)**

**EX: 0.22 ± 0.03 mm (0.009 ± 0.001 in)**





## MAINTENANCE

Rotate the crankshaft counterclockwise 120° and align the T3.4 mark with the index mark. Check the No. 4 cylinder valve clearance.

Rotate the crankshaft counterclockwise 120° and align the T5.6 mark with the index mark. Check the No. 5 cylinder valve clearance.

Rotate the crankshaft counterclockwise 120° and align the T1.2 mark with the index mark. Check the No. 2 cylinder valve clearance.

Rotate the crankshaft counterclockwise 120° and align the T3.4 mark with the index mark. Check the No. 3 cylinder valve clearance.

Rotate the crankshaft counterclockwise 120° and align the T5.6 mark with the index mark. Check the No. 6 cylinder valve clearance.

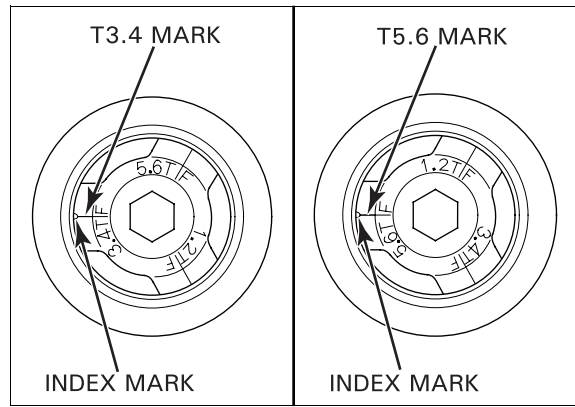

## ADJUSTMENT

Remove the valve lifters and shims (page 8-10).

Clean the valve shim contact area in the valve lifter with compressed air.

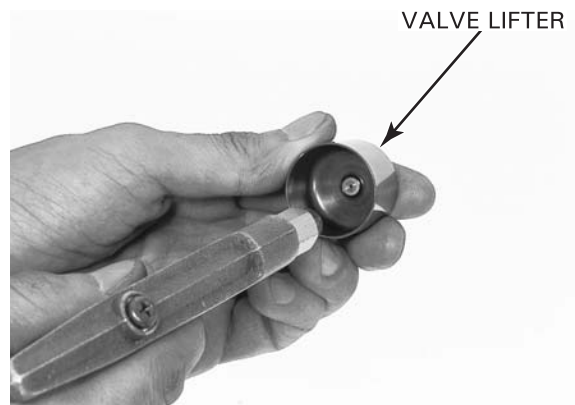

Measure the shim thickness and record it.

### NOTE:

- Sixty-five different shim thicknesses are available in increments of 0.025 mm (from 1.200 mm to 2.800 mm).

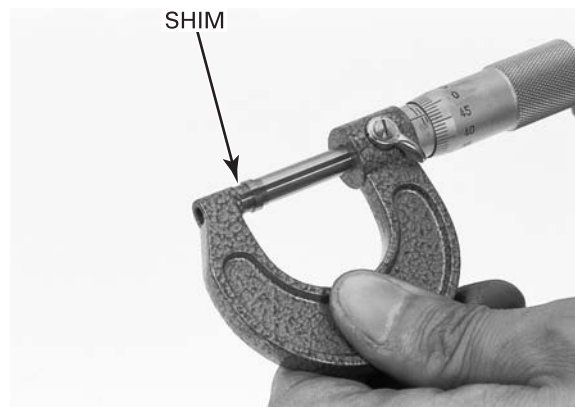

Calculate the new shim thickness using the equation below.

$$A = (B - C) + D$$

A: New shim thickness

B: Recorded valve clearance

C: Specified valve clearance

D: Old shim thickness

### NOTE:

- Make sure of the correct shim thickness by measuring the shim with the micrometer.
- Reface the valve seat if carbon deposits result in a calculated dimension of over 2.800 mm.

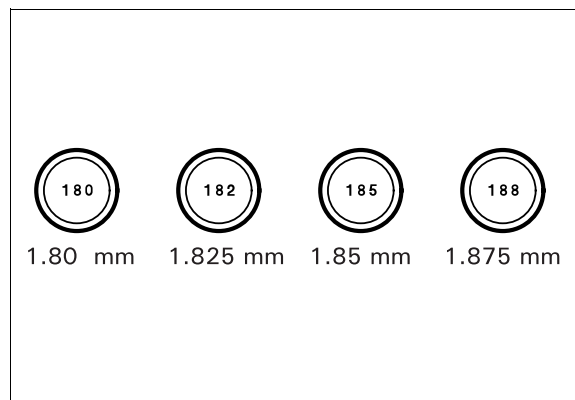

Install the newly selected shims on the valve retainers.

Install the valve lifters and camshafts (page 8-28).

Rotate the camshafts by rotating the crankshaft counterclockwise several times.

Recheck the valve clearances.

Install a new gasket into the groove in the cylinder head cover.

Apply sealant to the cylinder head as shown.

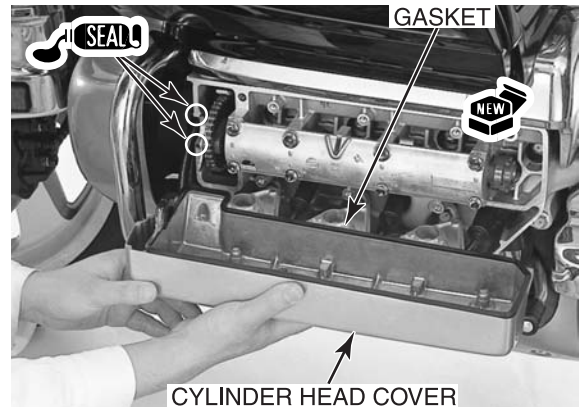

Install and tighten the cylinder head cover bolts.

**TORQUE: 12 N·m (1.2 kgf·m, 9 lbf·ft)**

Install the rubber plugs.

Install the cylinder head side covers (page 3-8).

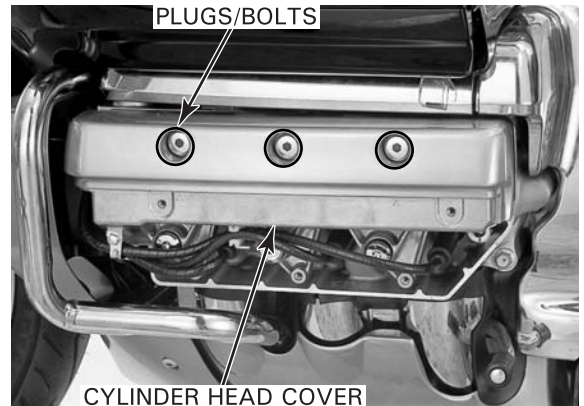

Coat a new O-ring with grease and install it onto the timing hole cap.

Apply grease to the timing hole cap threads. Install and tighten the timing hole cap.

**TORQUE: 18 N·m (1.8 kgf·m, 13 lbf·ft)**

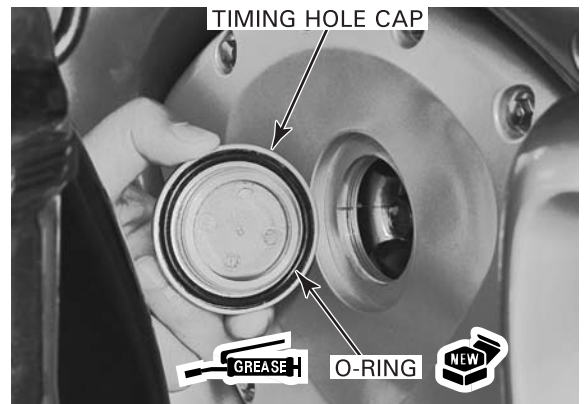

## ENGINE OIL

### OIL LEVEL CHECK

Start the engine and let it idle for a few minutes.

Stop the engine, place the motorcycle on its center stand on a level surface.

Remove the right engine side cover (page 2-5).

Wait for 2 or 3 minutes after stopping the engine. Remove the oil filler cap/dipstick and wipe the oil from the dipstick with a clean cloth.

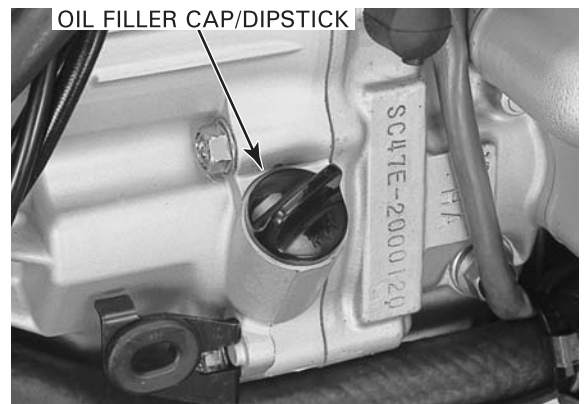

## MAINTENANCE

Insert the dipstick without screwing it in, remove it and check the oil level.

If the oil level is below or near the lower level mark on the dipstick, add the recommended oil up to the upper level mark.

### RECOMMENDED ENGINE OIL:

**Pro Honda GN4 or HP4 (without molybdenum additives) 4-stroke oil or equivalent motor oil**

**API service classification: SG or higher**

**JASO T 903 standard: MA**

**Viscosity: SAE 10W-40**

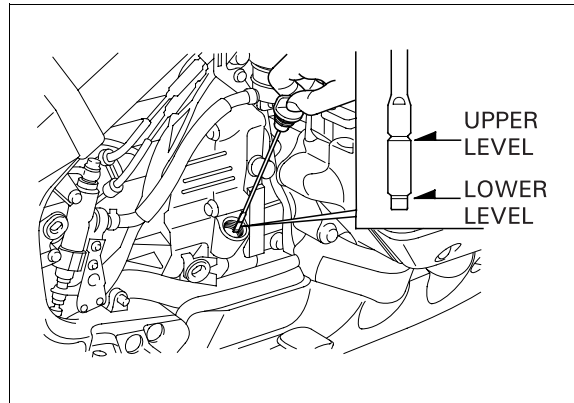

### NOTE:

- Other viscosities shown in the chart may be used when the average temperature in your riding area is within the indicated range.

Reinstall the oil filler cap/dipstick.

Install the right engine side cover (page 2-5).

For engine oil change, see page 3-12.

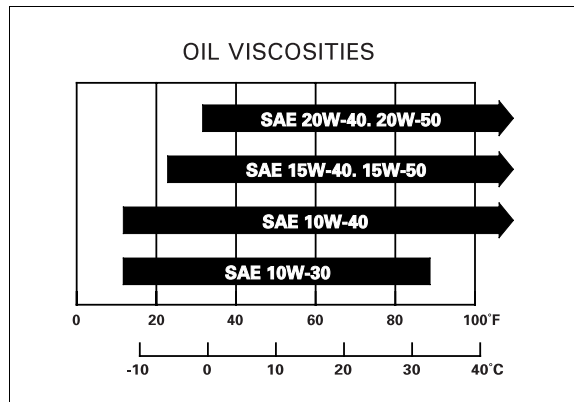

## ENGINE OIL FILTER

### NOTE:

- Change the oil with the engine warm and the motorcycle on its side stand to assure complete and rapid draining.

Warm up the engine.

Stop the engine and remove the following:

- right engine side cover (page 2-5)
- front lower fairing (page 2-6)

Remove oil filler cap/dipstick and drain bolt, and drain the oil.

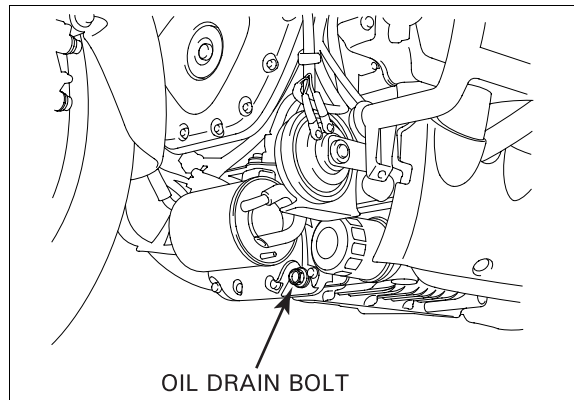

Remove the oil filter cartridge and let the remaining oil drain out.

### TOOL:

Oil filter wrench

07HAA-PJ70100



Apply oil to the seal rubber and threads of a new oil filter cartridge and install the filter cartridge.

**Oil filter wrench** **07HAA-PJ70100**

**TORQUE: 26 N·m (2.7 kgf·m, 20 lbf·ft)**



Install the oil drain bolt with a new sealing washer and tighten it.

**TORQUE: 34 N·m (3.5 kgf·m, 25 lbf·ft)**

Fill the crankcase with the recommended oil (page 3-11).

**OIL CAPACITY:**

- 3.6 liters (3.8 US qt, 3.2 Imp qt) at draining**
- 3.7 liters (3.9 US qt, 3.3 Imp qt) at filter change**
- 4.6 liters (4.9 US qt, 4.0 Imp qt) at disassembly**

Check the engine oil level (page 3-11).  
Install the oil filler cap/dipstick.  
Make sure there are no oil leaks.

Install the following:

- right engine side cover (page 2-5)
- front lower cover (page 2-13)

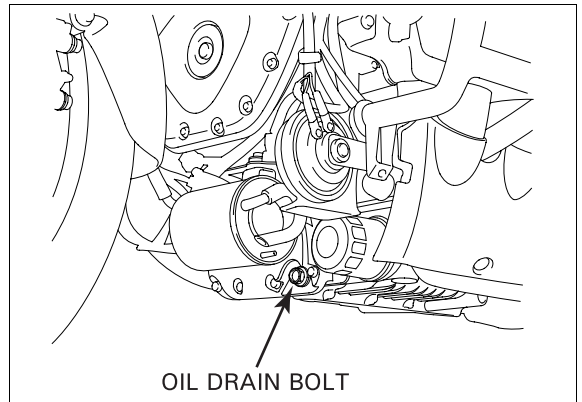

## RADIATOR COOLANT

Check the coolant level of the reserve tank with the engine running at normal operating temperature.

Remove the left engine side cover (page 2-5).

Remove the reserve tank cap/dipstick.



The level should be between the upper and lower level holes on the dipstick with the motorcycle on its center stand on a level surface.

If the level is low, fill the tank to the upper level hole with a 1:1 mixture of distilled water and antifreeze (coolant preparation: page 6-6).

**RECOMMENDED ANTIFREEZE:**

**Pro Honda HP coolant or an equivalent high quality ethylene glycol antifreeze containing silicate-free corrosion inhibitors**

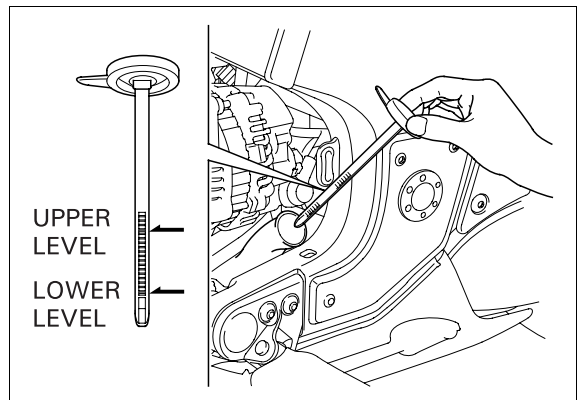

### NOTICE

*Using coolant with silicate corrosion inhibitors may cause premature wear of water pump seals or blockage of radiator passages. Using tap water may cause engine damage.*

Check to see if there are any coolant leaks when the coolant level decreases very rapidly.

If the reserve tank becomes completely empty, there is a possibility of air getting into the cooling system. Be sure to remove all air from the cooling system (page 6-7).

## COOLING SYSTEM

Remove the radiator grilles (page 6-9).

Check for any coolant leakage from the radiator hoses and hose joints.

Check the radiator hoses for cracks or deterioration and replace if necessary.

Check that all hose clamps are tight.

Check the radiator air passage for clogs or damage. Straighten bent fins with a small, flat blade screwdriver and remove insects, mud or other obstructions with compressed air or low pressure water. Replace the radiator if the air flow is restricted over more than 20% of the radiating surface.

Install the radiator grilles and removed parts (page 6-13).

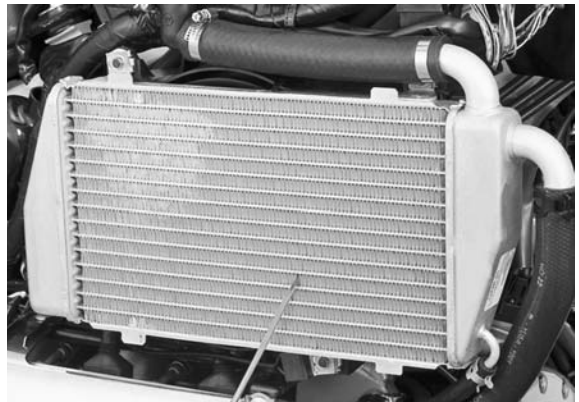

## SECONDARY AIR SUPPLY SYSTEM

Remove the air cleaner housing (page 5-57).

Check the air supply hoses between the pulse secondary air injection (PAIR) control solenoid valve and PAIR check valves for damage or loose connections.

Check the air supply hoses for cracks or deterioration.

If the hoses show any signs of heat damage, inspect the PAIR check valves (page 5-72).

For PAIR control solenoid valve inspection, see page 5-72.

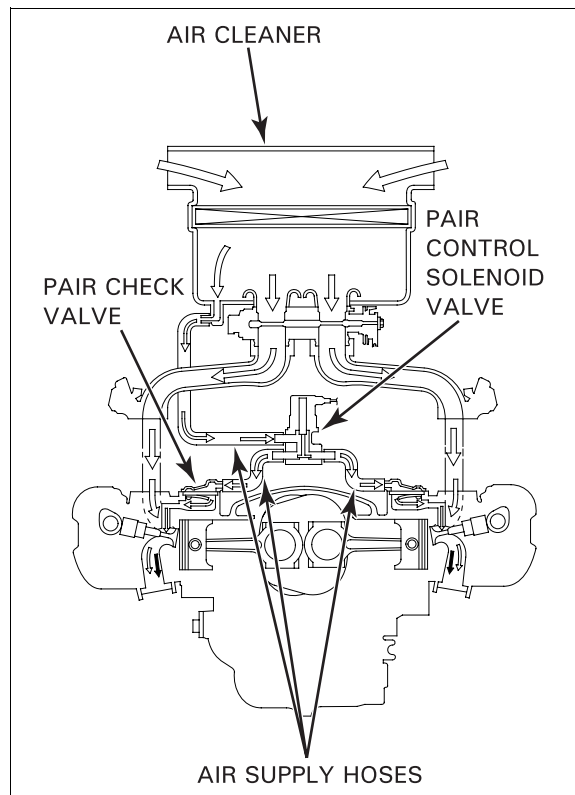



## EVAPORATIVE EMISSION CONTROL SYSTEM

Remove the air cleaner housing (page 5-57).

Check the evaporative emission (EVAP) canister, which is located in front of the engine, for cracks or damage.

Check the hoses between the fuel tank, EVAP canister, EVAP purge control valve solenoid and throttle body for deterioration, damage or loose connections. Also check that the hoses are not kinked or pinched.

Refer to the Vacuum Hose Routing Diagram Label and Cable & Harness Routing (page 1-23) for hose connections and routing.

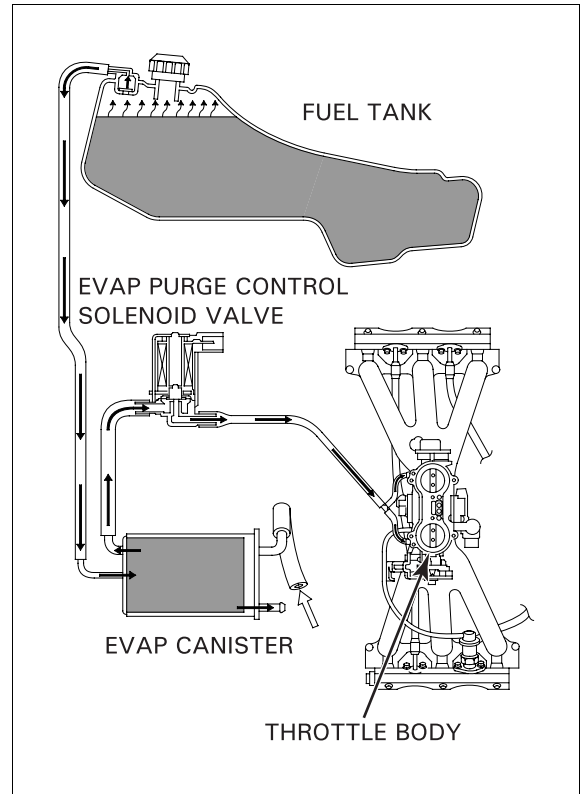

## FINAL DRIVE OIL

### OIL LEVEL CHECK

Place the motorcycle on its center stand on a level surface.

Remove the oil filler cap from the final gear case. Check that the oil level is to the lower edge of the oil filler hole.

Check for leaks if the oil level is low. Pour the recommended oil through the oil filler hole until it reaches the lower edge of the hole.

**RECOMMENDED OIL: Hypoid gear oil, SAE #80**

Coat a new O-ring with oil and install it onto the oil filler cap.

Install and tighten the oil filler cap.

**TORQUE: 12 N·m (1.2 kgf·m, 9 lbf·ft)**

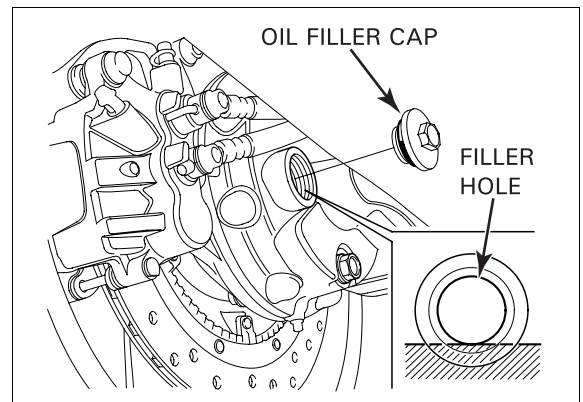

## MAINTENANCE

### OIL CHANGE

Remove the oil filler cap and drain bolt from the final gear case, slowly turn the rear wheel and drain the oil.

After the oil is completely drained, install the drain bolt with a new sealing washer and tighten it.

**TORQUE: 2.0 N·m (20 kgf·m, 14 lbf·ft)**

Fill the final gear case with the recommended oil to the correct level (page 3-16).

#### OIL CAPACITY:

**120 cm<sup>3</sup> (4.1 US oz, 4.2 Imp oz) after draining**

**150 cm<sup>3</sup> (5.1 US oz, 5.3 Imp oz) after disassembly**

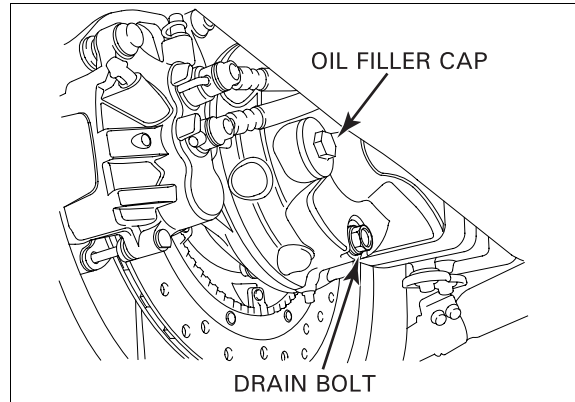

## BRAKE FLUID

### NOTICE

- *Spilling fluid can damage painted, plastic or rubber parts. Place a rag over these parts whenever the system is serviced.*

#### NOTE:

- Do not mix different types of fluid, as they are not compatible with each other.
- Do not allow foreign material to enter the system when filling the reservoir.
- When the fluid level is low, check the brake pads for wear (page 3-18). A low fluid level may be due to wear of the brake pads. If the brake pads are worn and the caliper pistons are pushed out, this accounts for a low reservoir level. If the brake pads are not worn and the fluid level is low, check the entire system for leaks (page 3-18).

### FRONT BRAKE

Turn the handlebar to the left side so the reservoir is level and check the front brake reservoir fluid level through the sight glass.



If the fluid level is near the "LOWER" level mark, remove the reservoir cap, set plate and diaphragm, and fill the reservoir with DOT 4 brake fluid from a sealed container to the casting ledge.

Install the diaphragm, set plate and reservoir cap and tighten the cap screws.

**TORQUE: 2 N·m (0.2 kgf·m, 1.4 lbf·ft)**

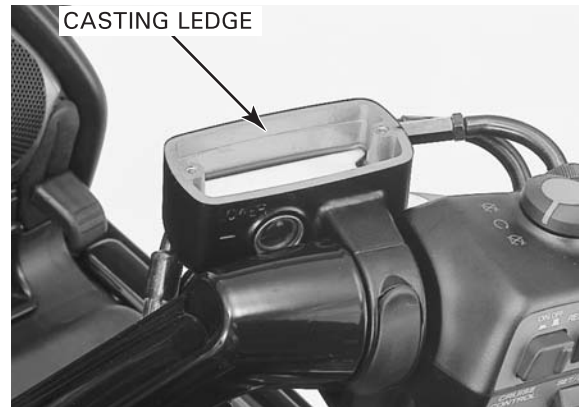

**REAR BRAKE**

Place the motorcycle on its center stand on a level surface.

Remove the right engine side cover (page 2-5).

Check the fluid level in the rear brake reservoir. If the level is near the "LOWER" level line, remove the reservoir cap, set plate and diaphragm, and fill the reservoir with DOT 4 brake fluid from a sealed container to the "UPPER" level line.

Install the diaphragm, set plate and reservoir cap. Install the right engine side cover (page 2-5).

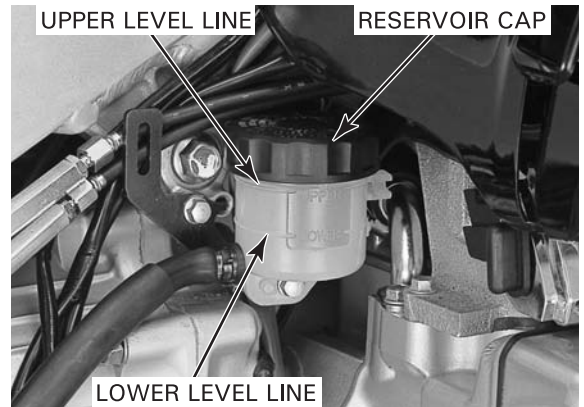

**BRAKE PAD WEAR**

Check the brake pads for wear. Replace the brake pads if either pad is worn to the bottom of the wear limit groove.

Refer to page 15-13 for brake pad replacement.

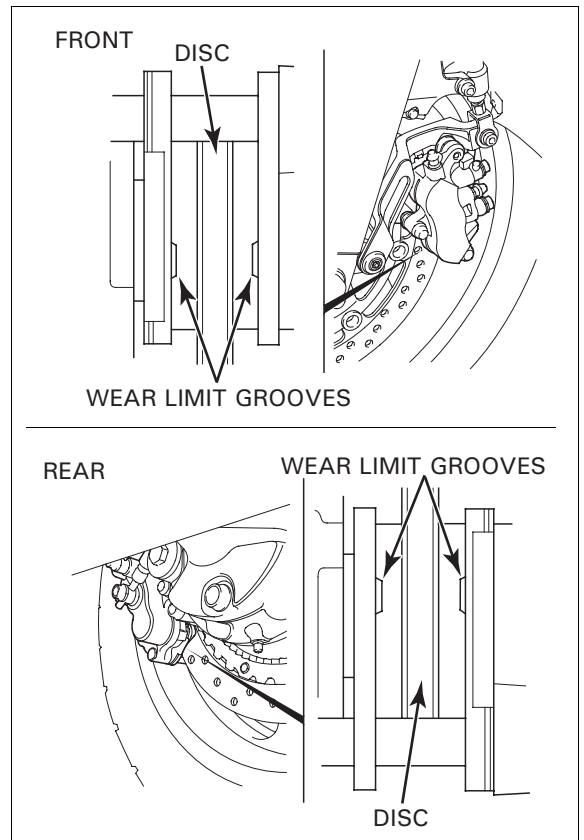



## MAINTENANCE

### BRAKE SYSTEM

Firmly apply the brake lever or pedal, and check that no air has entered the system. If the lever or pedal feels soft or spongy when operated, bleed the air from the system.

Refer to page 15-8 for air bleeding procedures.

Inspect the brake hoses, pipes and fittings for deterioration, cracks, damage or signs of leakage. Tighten any loose fittings. Replace hoses, pipes and fittings as required.



Place the motorcycle on its center stand, stop the engine and shift the transmission into neutral.

Move the left front caliper assembly upward while slowly turning the rear wheel. The brake system is normal if the rear wheel stops.

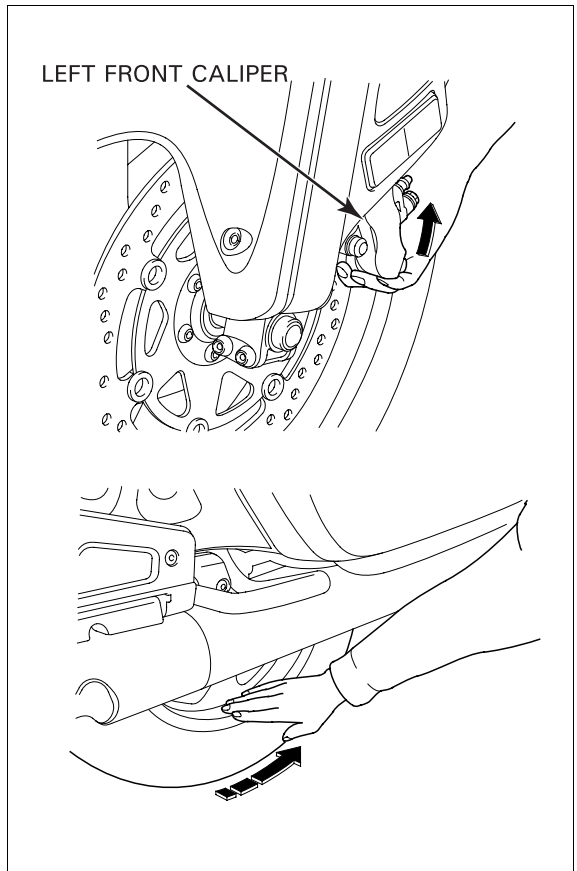

### BRAKE LIGHT SWITCH

NOTE:

- The brake light switches cannot be adjusted. If the brake light switch actuation and brake engagement are not synchronized, either replace the switch unit or the malfunctioning parts of the system.

Check that the brake light comes on just prior to the brake actually being engaged.

## HEADLIGHT AIM

Remove the inner fairings (page 2-10).

Start the engine and move the headlight beams to the highest position by turning the headlight beam adjusting knob clockwise fully.

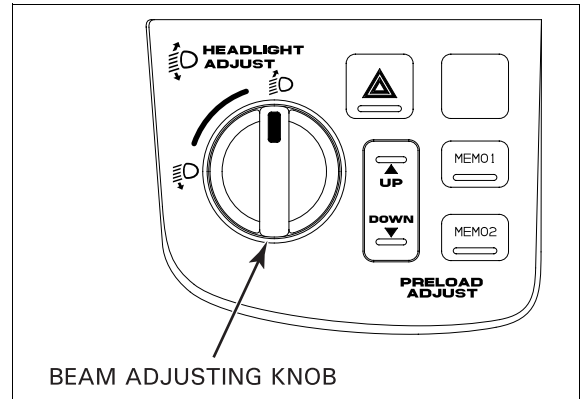

Stop the engine and place the motorcycle on a level surface.

*Adjust the headlight beam as specified by local laws and regulations.*

Adjust the headlight beams vertically by turning the vertical adjusting screws.

Adjust the headlight beams horizontally by turning the horizontal adjusting screws.

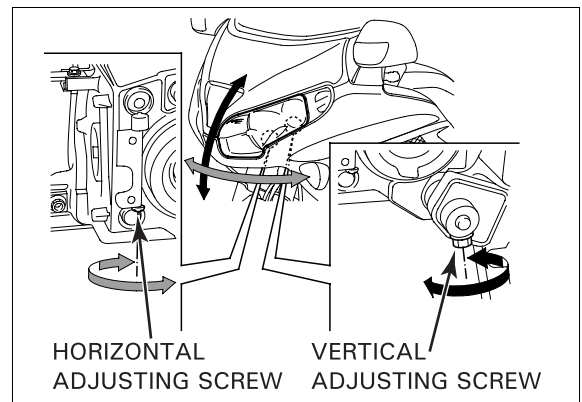

## CLUTCH SYSTEM

Operate the clutch lever and check that no air has entered the system.

If the clutch is not disengaged properly, or the lever feels soft or spongy, bleed the air from the system.

Refer to page 9-7 for air bleeding procedures.

Inspect the clutch hoses, pipe and fittings for damage, deterioration, cracks or leakage.

Tighten any loose fittings.

Replace hoses, pipe and fittings as required.

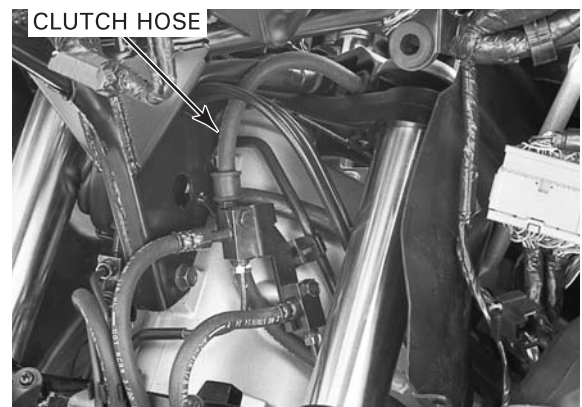

## CLUTCH FLUID

NOTE:

- When the fluid level is low, check entire system for leaks.
- Do not mix different types of fluid, as they are not compatible with each other.
- Do not allow foreign material to enter the system when filling the reservoir.

### NOTICE

- *Spilling fluid can damage painted, plastic or rubber parts. Place a rag over these parts whenever the system is serviced.*

## MAINTENANCE

Turn the handlebar to the right side so that the reservoir is level and check the clutch reservoir fluid level through the sight glass.

If the level is near the "LOWER" level mark, remove the reservoir cap, set plate and diaphragm, and fill the reservoir with DOT 4 brake fluid from a sealed container to the casting ledge.

Install the diaphragm, set plate and reservoir cap and tighten the cap screws.

**TORQUE: 2 N·m (0.2 kgf·m, 1.4 lbf·ft)**



## REVERSE OPERATION

Sit astride the motorcycle with both feet on the ground.

Shift the transmission into neutral, retract the side stand and start the engine.

Push the reverse switch and check that the neutral indicator goes off and the reverse indicator comes on.

Check that the motorcycle moves in reverse while pushing the starter/reverse switch.

For reverse system inspection, see section 18.

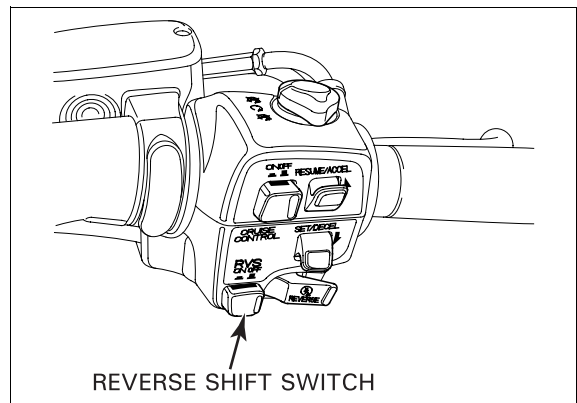

## SIDE STAND

Place the motorcycle on its center stand.

Check the side stand spring for damage or loss of tension.

Check the side stand assembly for freedom of movement and lubricate the side stand pivot if necessary.

Check the side stand ignition cut-off system:

- Sit astride the motorcycle and raise the side stand.
- Start the engine with the transmission in neutral, then shift the transmission into gear, while squeezing the clutch lever.
- Fully lower the side stand.
- The engine should stop as the side stand is lowered.

If there is a problem with the system, check the side stand switch (page 20-39).

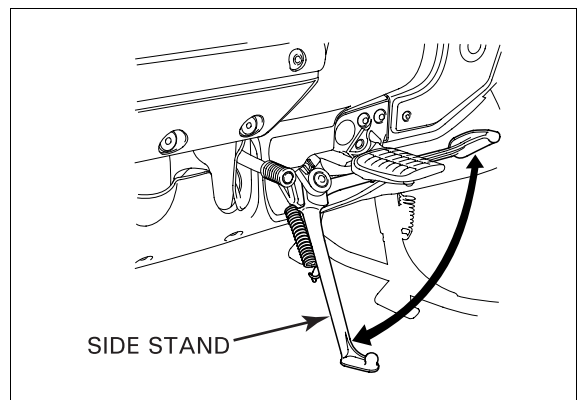

## SUSPENSION

### FRONT SUSPENSION INSPECTION

Check the action of the forks by applying the front brakes and compressing the front suspension several times.

Check the entire assembly for leaks, damage or loose fasteners.

Replace damaged components which cannot be repaired.

Tighten all nuts and bolts.

Refer to section 13 for fork service.



### REAR SUSPENSION INSPECTION

Check the action of the shock absorber by compressing it several times.

Check the entire shock absorber assembly for leaks, damage or loose fasteners.

Replace damaged components which cannot be repaired.

Tighten all nuts and bolts.

Refer to section 14 for shock absorber service.



Place the motorcycle on its center stand.

Check for worn swingarm bearings by grabbing the rear wheel and attempting to move the wheel side to side.

Replace the bearings if any looseness is noted (section 14).



## NUTS, BOLTS, FASTENERS

Check that all chassis nuts and bolts are tightened to their correct torque values (page 1-12).

Check that all cotter pins, safety clips, hose clamps and cable stays are in place and properly secured.

## MAINTENANCE

### WHEELS/TIRES

Check the tire pressure with the tire pressure gauge when the tires are cold.

#### RECOMMENDED TIRE PRESSURE:

**Up to 90 kg (200 lbs) load:**

**Front: 250 kPa (2.50 kgf/cm<sup>2</sup>, 36 psi)**

**Rear: 280 kPa (2.80 kgf/cm<sup>2</sup>, 41 psi)**

**Up to maximum weight capacity:**

**Front: 250 kPa (2.50 kgf/cm<sup>2</sup>, 36 psi)**

**Rear: 280 kPa (2.80 kgf/cm<sup>2</sup>, 41 psi)**

Check the tires for cuts, embedded nails, or other damage.

Check the front and rear wheels for trueness (refer to sections 13 and 14).

Measure the tread depth at the center of the tires. Replace the tires when the tread depth reaches the following limits.

**MINIMUM TREAD DEPTH: Front: 1.5 mm (0.06 in)**

**Rear: 2.0 mm (0.08 in)**



### STEERING HEAD BEARINGS

Place the motorcycle on its center stand.

Raise the front wheel off the ground by placing a jack under the engine.

Check that the handlebar moves freely from side to side. Make sure the control cables do not interfere with the handlebar rotation.

If the handlebar moves unevenly, binds, or has vertical movement, inspect the steering head bearings (section 13).



# 4. LUBRICATION SYSTEM

---

LUBRICATION SYSTEM DIAGRAM .....	4-2	OIL PRESSURE CHECK .....	4-5
SERVICE INFORMATION .....	4-3	OIL STRAINER/PRESSURE RELIEF VALVE .....	4-6
TROUBLESHOOTING .....	4-4	OIL PUMP.....	4-7

LUBRICATION SYSTEM

LUBRICATION SYSTEM DIAGRAM

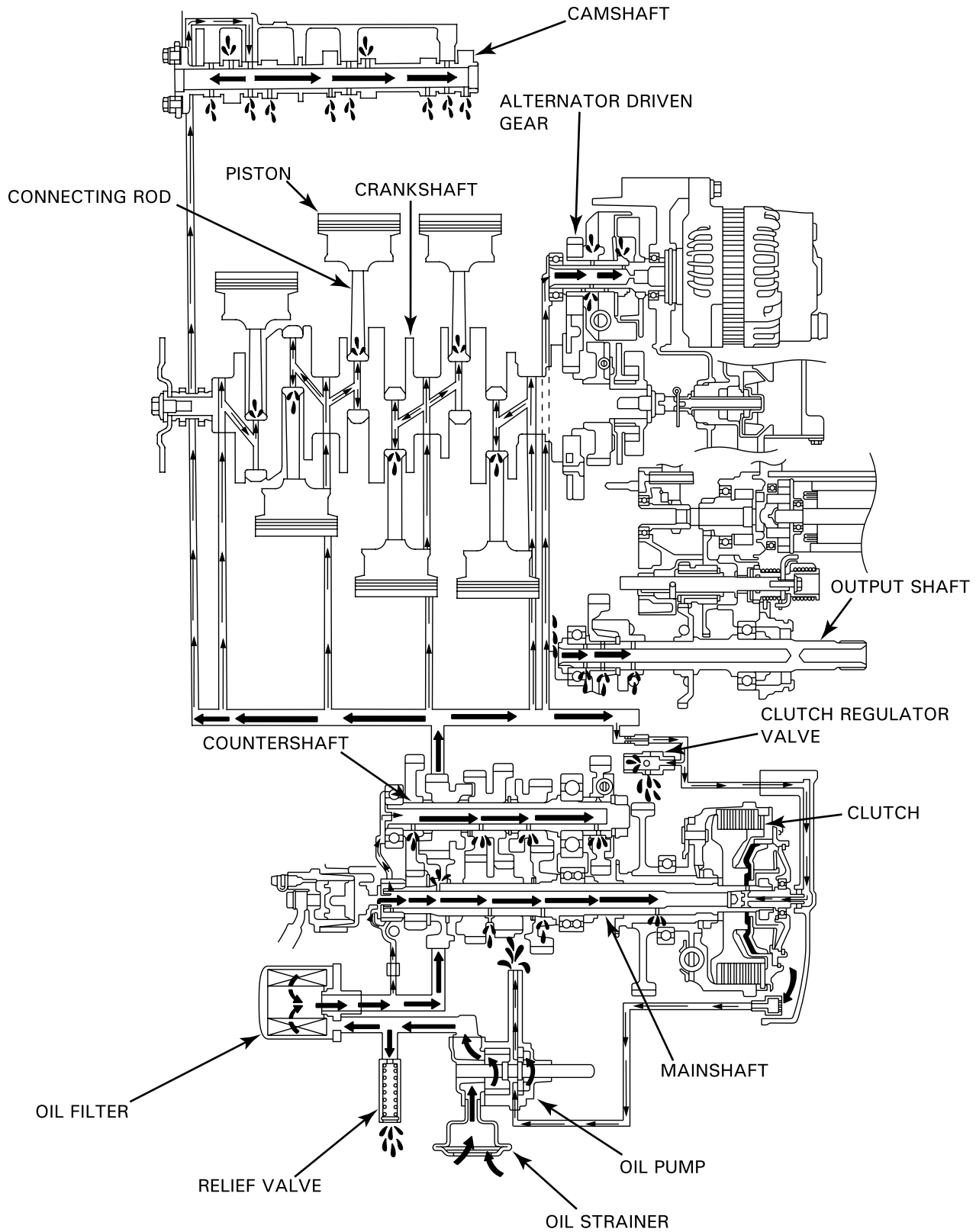

# SERVICE INFORMATION

## GENERAL

### ⚠ CAUTION

Used engine oil may cause skin cancer if repeatedly left in contact with the skin for prolonged periods. Although this is unlikely unless you handle used oil on a daily basis, it is still advisable to thoroughly wash your hands with soap and water as soon as possible after handling used oil.

- The oil pump has twin pump rotors; main and scavenging. The main rotors pick up oil from the crankcase and delivers it under pressure to the bearing and other important parts of the engine. The scavenge rotors draw oil from the clutch housing in the rear case and sends it to the primary drive and driven gears to lubricate and cool them.
- The crankcase must be separated to service the oil pump (page 11-6).
- For engine oil level check, See page 3-11.
- For engine oil and filter change, See page 3-12.
- For final drive oil check and change, See page 3-15.
- For oil pressure switch inspection, see page 20-27.

## SPECIFICATIONS

Unit: mm (in)

ITEM		STANDARD	SERVICE LIMIT	
Engine oil capacity	After draining	3.6 liters (3.8 US qt, 3.2 Imp qt)	-	
	After draining/filter change	3.7 liters (3.9 US qt, 3.3 Imp qt)	-	
	After disassembly	4.6 liters (4.9 US qt, 4.0 Imp qt)	-	
Recommended engine oil		Pro Honda GN4 or HP4 (without molybdenum additives) 4-stroke oil or equivalent motor oil API service classification SG or higher JASO T 903 standard: MA Viscosity: SAE 10W-40	-	
Oil pressure (at oil pressure switch)		530 kPa (5.4 kgf/cm <sup>2</sup> , 77 psi) at 5,000 rpm/80° C (176° F)	-	
Oil pump	Tip clearance	0.15 (0.006)	0.20 (0.008)	
	Body clearance	Feed side	0.15-0.21 (0.006-0.008)	0.35 (0.014)
		Scavenge side	0.15-0.22 (0.006-0.009)	0.35 (0.014)
	Side clearance	0.02-0.09 (0.001-0.004)	0.12 (0.005)	

## TORQUE VALUES

- |                        |                              |                                     |
|------------------------|------------------------------|-------------------------------------|
| Oil pressure switch    | 12 N·m (1.2 kgf·m, 9 lbf·ft) | Apply sealant to the threads.       |
| Oil strainer bolt      | 12 N·m (1.2 kgf·m, 9 lbf·ft) | Apply locking agent to the threads. |
| Oil pump assembly bolt | 13 N·m (1.3 kgf·m, 9 lbf·ft) |                                     |

## TOOLS

<p>Oil pressure gauge set 07506-300001</p>  <p>or equivalent commercially available in U.S.A.</p>	<p>Oil pressure gauge attachment 07510-4220100</p>  <p>or equivalent commercially available in U.S.A.</p>	<p>Oil filter wrench 07HAA-PJ70101</p>  <p>or 07HAA-PJ70100</p>
--	--	--



## LUBRICATION SYSTEM

---

### TROUBLESHOOTING

#### **Oil level too low**

- Oil consumption
- External oil leak
- Worn piston rings
- Improperly installed piston rings
- Worn cylinders
- Worn stem seals
- Worn valve guide

#### **Low oil pressure**

- Oil level low
- Clogged oil strainer
- Faulty oil pump
- Internal oil leak
- Incorrect oil being used

#### **No oil pressure**

- Oil level too low
- Oil pressure relief valve stuck open
- Broken oil pump drive chain
- Broken oil pump drive or driven sprocket
- Damaged oil pump
- Internal oil leak

#### **High oil pressure**

- Oil pressure relief valve stuck closed
- Clogged oil gallery or metering orifice
- Incorrect oil being used

#### **Oil contamination**

- Oil or filter not changed often enough
- Worn piston rings

#### **Oil emulsification**

- Blown cylinder head gasket
- Leaky coolant passage
- Entry of water

## OIL PRESSURE CHECK

Remove the left exhaust pipe protector (page 2-18).

If the engine is cold, the pressure reading will be abnormally high.

Warm up the engine to normal operating temperature before checking the oil pressure.

Stop the engine.

Remove the switch cover and disconnect to the oil pressure switch wire by removing the terminal screw.

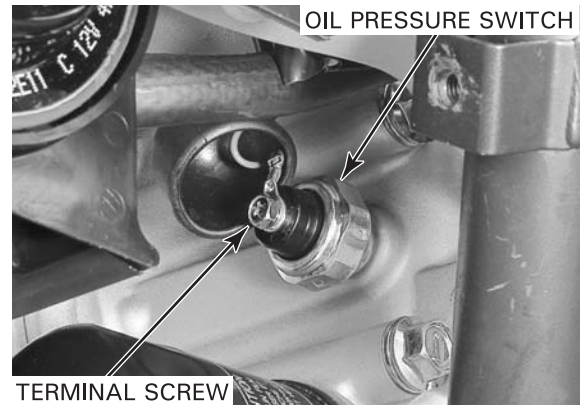

Remove the oil pressure switch and connect an oil pressure gauge attachment and gauge to the pressure switch hole.

### TOOLS:

**Oil pressure gauge attachment** 07510-4220100  
or equivalent commercially available in U.S.A.

**Oil pressure gauge** 07506-3000000  
or equivalent commercially available in U.S.A.

Check the oil level and add the recommended oil if necessary (page 3-11).

Start the engine and check the oil pressure at 5,000 rpm (80°C/176°F).

**OIL PRESSURE: 530 kPa (5.4 kgf/cm<sup>2</sup>, 77 psi)**

Stop the engine.

Apply sealant to the oil pressure switch threads as shown and install it.

**TORQUE: 12 N·m (1.2 kgf·m, 9 lbf·ft)**

Connect the oil pressure switch wire and tighten the terminal screw.

Install the switch cover.

Start the engine.

Check that the oil pressure indicator turns off after 1 or 2 seconds. If the oil pressure indicator stays on, stop the engine immediately and determine the cause (page 20-27).

Install the left exhaust pipe protector (page 2-18).

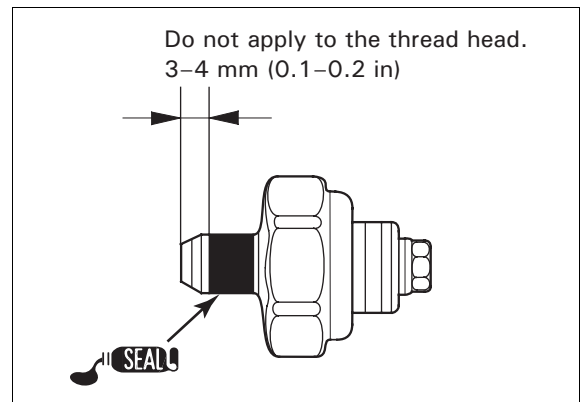
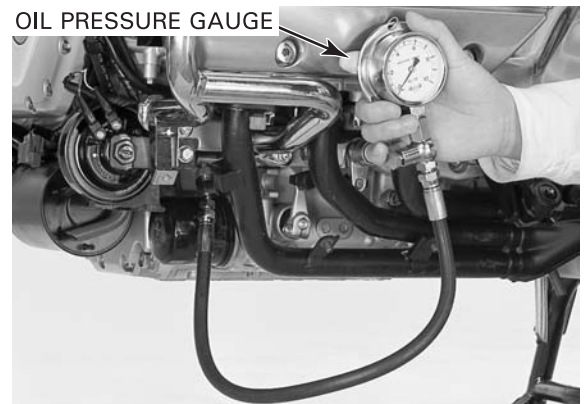

## LUBRICATION SYSTEM

# OIL STRAINER/PRESSURE RELIEF VALVE

Separate the crankcase (page 11-6).

### OIL STRAINER

Remove the strainer bolt and oil strainer from the oil pump.

Remove the oil strainer packing.



Clean the oil strainer thoroughly.

Apply engine oil to the new packing and install it onto the oil pump.

Apply locking agent to the oil strainer bolt threads. Install the oil strainer onto the oil pump with the strainer bolt.

Tighten the bolt to the specified torque.

**TORQUE: 12 N·m (1.2 kgf·m, 9 lbf·ft)**

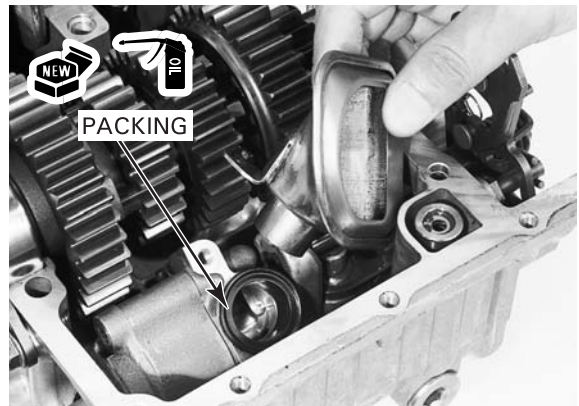

### OIL PRESSURE RELIEF VALVE

Remove the oil pressure relief valve and O-ring.

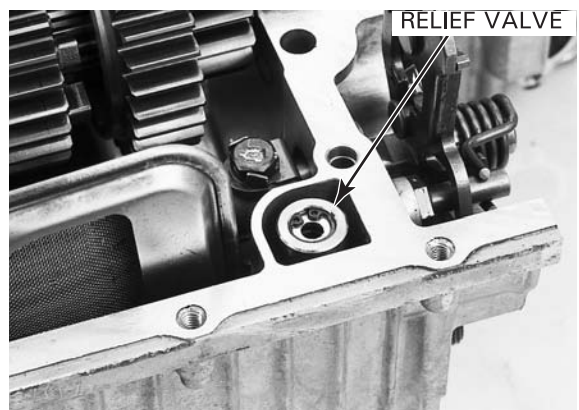

Check the operation of the pressure relief valve by pushing on the piston.  
Disassemble the relief valve by removing the snap ring.



Inspect the piston for wear, unsmooth movement or damage.  
Inspect the spring for fatigue or damage.  
Assemble the relief valve in the reverse order of disassembly.

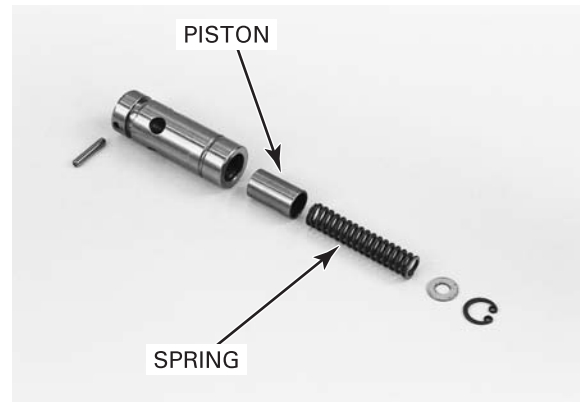

Apply engine oil to the new O-ring and install it onto the relief valve.  
Install the relief valve into the crankcase.  
Assemble the crankcase (page 11-22).



## OIL PUMP

### REMOVAL

Remove the transmission (page 10-26).  
Remove the strainer bolt and oil strainer from the oil pump.  
Remove the oil strainer packing.

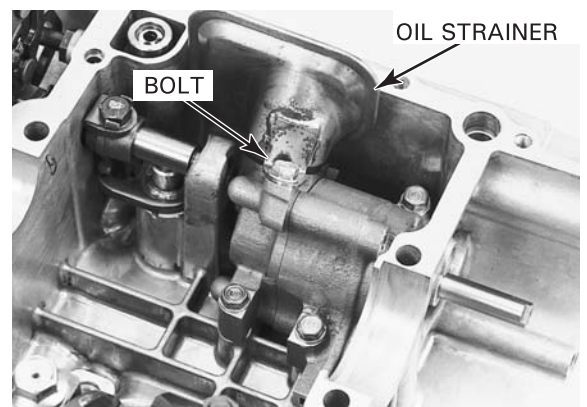

## LUBRICATION SYSTEM

Remove the three mounting bolts and oil pump from the crankcase.

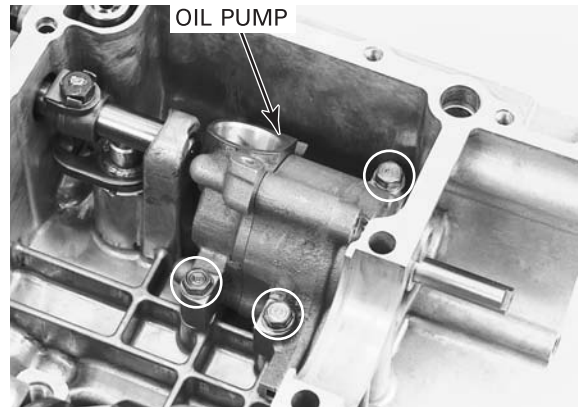

Remove the three dowel pins and two O-rings.

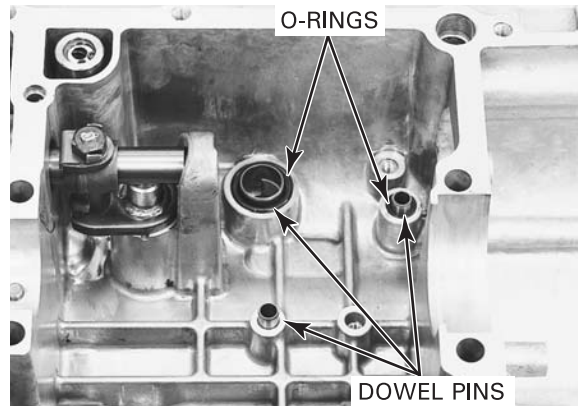

### DISASSEMBLY

Remove the three oil pump assembly bolts and oil pump cover B.

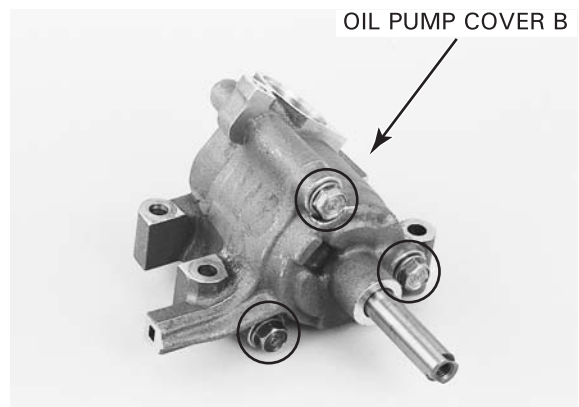

Remove the dowel pins from the oil pump body.

#### SCAVENGE PUMP SIDE:

Remove the drive pin from the oil pump shaft. Remove outer rotor B and inner rotor B from oil pump cover B.

Remove the oil seal from oil pump cover B to avoid damaging the cover.

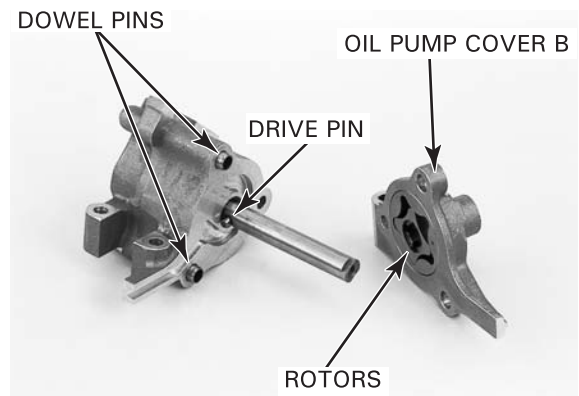

Remove oil pump cover A from the oil pump body.  
Remove the dowel pins from the cover.

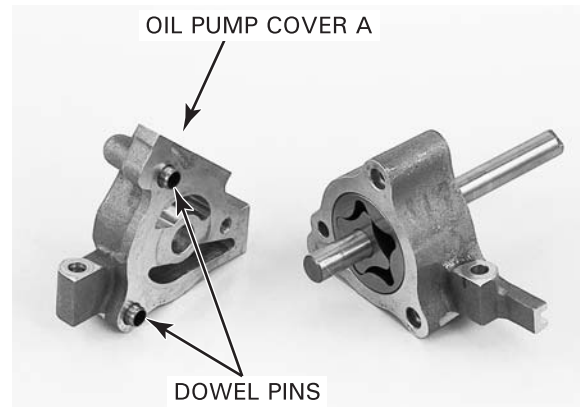

### FEED PUMP SIDE:

Remove the following from the oil pump body.

- oil pump shaft
- thrust washer
- drive pin
- inner rotor
- outer rotor

Remove the oil seal from the oil pump body to avoid damaging the pump body.

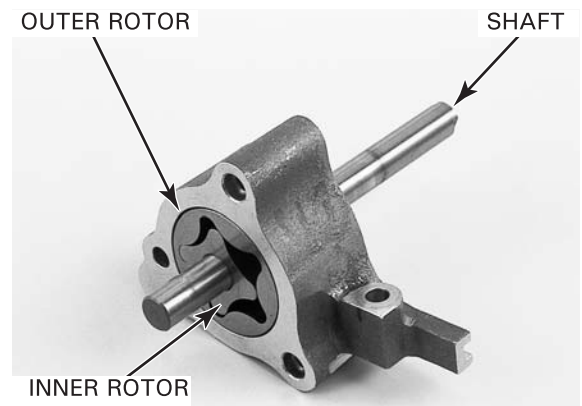

### INSPECTION

Temporarily assemble each inner rotor, outer rotor and drive pin onto the pump shaft, and install them into the pump body and pump cover B.

Measure the tip clearance for the feed and scavenge pumps.

**SERVICE LIMIT: 0.20 mm (0.008 in)**



Measure the pump body clearance for the feed and scavenge pumps.

**SERVICE LIMIT: 0.35 mm (0.014 in)**





## LUBRICATION SYSTEM

Measure the pump side clearance for the feed and scavenge pumps.

**SERVICE LIMIT: 0.12 mm (0.005 in)**

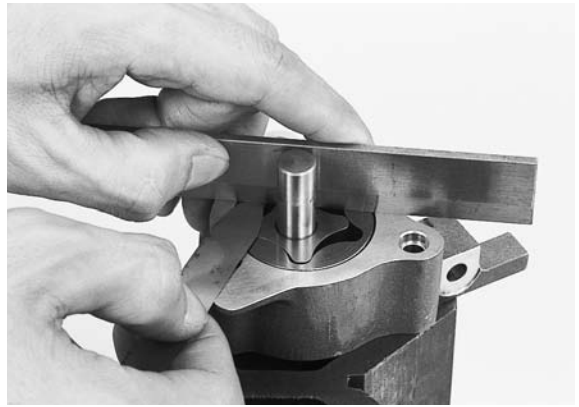

### ASSEMBLY

Dip all parts in clean engine oil.

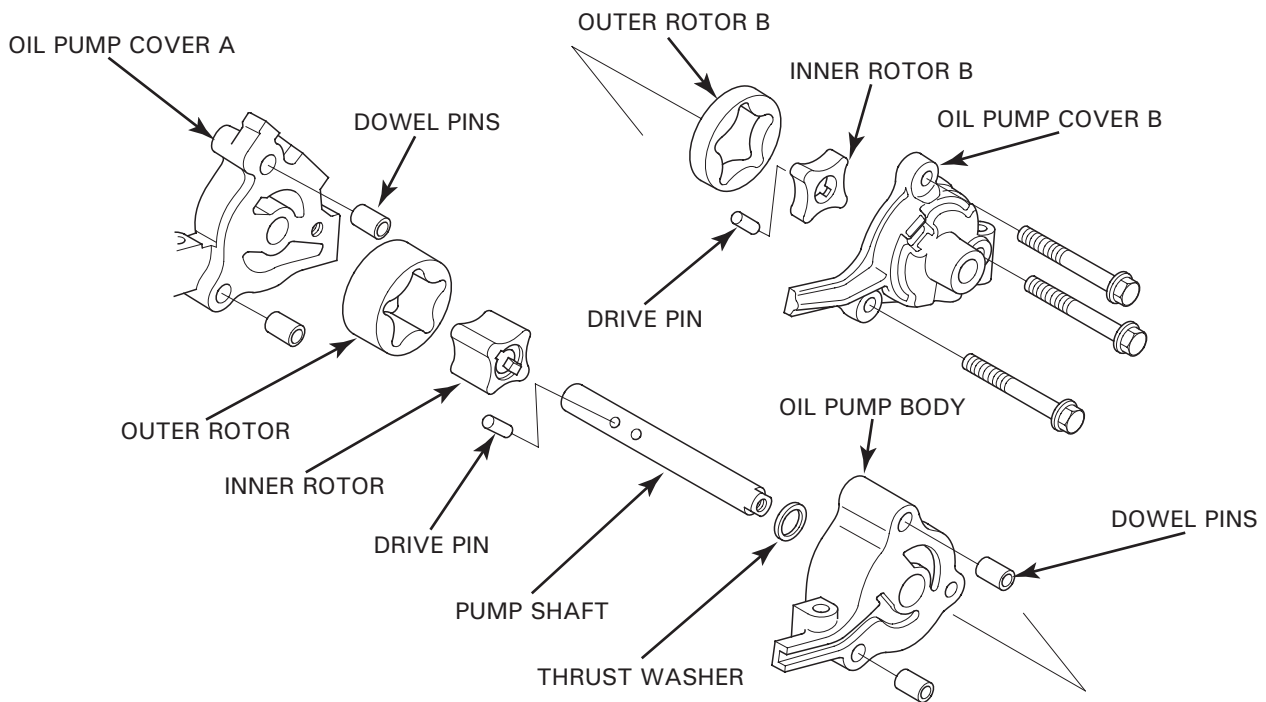

Coat the new oil seal lips with grease.  
Drive the new oil seals into the oil pump body and oil pump cover B with the sealed side facing up until they are fully seated using the suitable collar (15 mm O.D.).



Install the inner rotor onto the oil pump shaft.  
Install the drive pin into the pump shaft hole and align the drive pin with the groove in the inner rotor.  
Install the thrust washer onto the shaft.

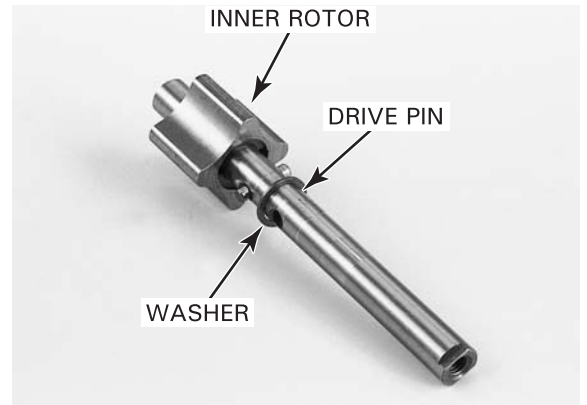

Install the assembled pump shaft into the oil pump body with the threaded hole end facing toward the pump body.  
Install the outer rotor into the pump body.

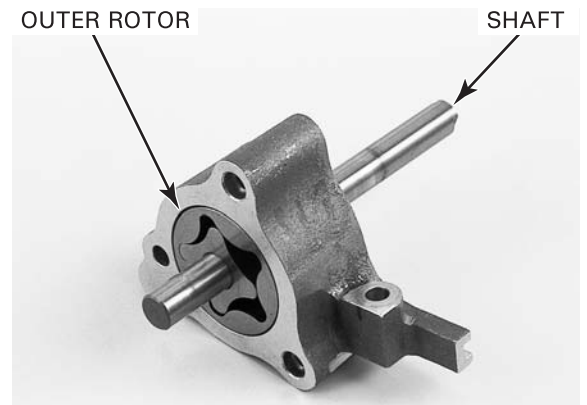

Install the dowel pins as shown.  
Assemble the oil pump body and pump cover A.

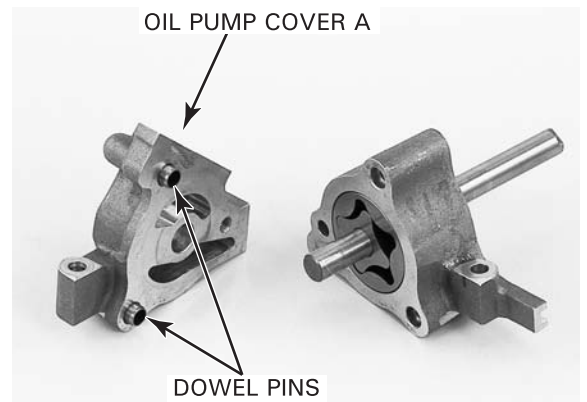

Install the drive pin into the pump shaft hole.  
Install outer rotor B and inner rotor B into pump cover B.

Install the dowel pins as shown.

Assemble the pump body and pump cover B by aligning the drive pin with the groove in inner rotor B.

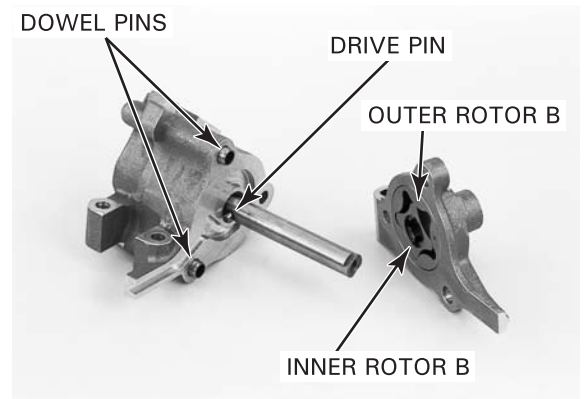



## LUBRICATION SYSTEM

Install the oil pump assembly bolts and tighten the bolts to the specified torque.

**TORQUE: 13 N·m (1.3 kgf·m, 9 lbf·ft)**



Install the three dowel pins.  
Coat the new O-rings with engine oil and install them.

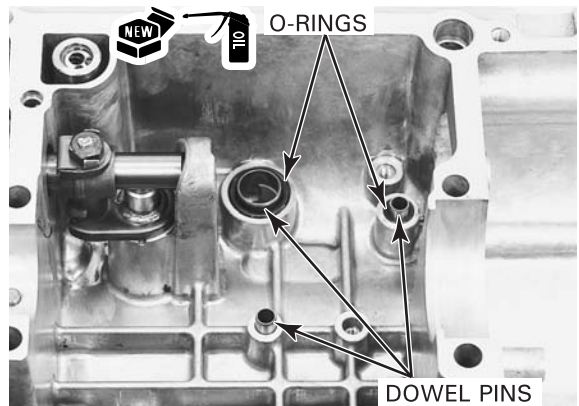

Install the oil pump with the three mounting bolts.  
Tighten the bolts securely.

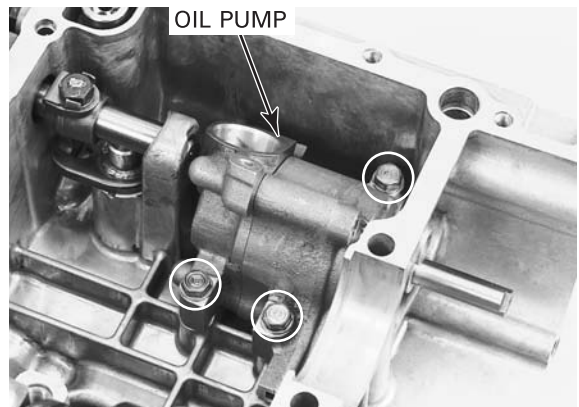

Apply engine oil to the new packing and install it onto the oil pump.  
Apply locking agent to the oil strainer bolt threads.  
Install the oil strainer onto the oil pump with the strainer bolt.  
Tighten the strainer bolt to the specified torque.

**TORQUE: 12 N·m (1.2 kgf·m, 9 lbf·ft)**

Install the transmission (page 10-26).

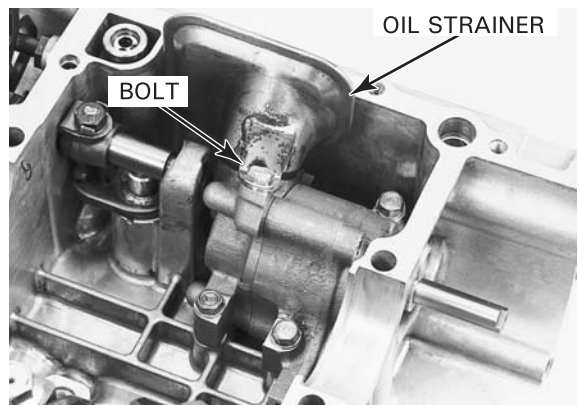

# 5. FUEL SYSTEM (Programmed Fuel Injection)

---

COMPONENT LOCATION.....	5-2	THROTTLE BODY.....	5-58
SERVICE INFORMATION.....	5-3	FUEL INJECTORS.....	5-61
TROUBLESHOOTING.....	5-5	FUEL PUMP RELAY.....	5-66
SYSTEM LOCATION.....	5-6	BARO/MAP SENSORS.....	5-67
SYSTEM DIAGRAM.....	5-7	IAT SENSOR.....	5-68
PGM-FI (PROGRAMMED FUEL INJECTION) SYSTEM.....	5-8	CAMSHAFT POSITION SENSOR.....	5-68
PGM-FI SELF-DIAGNOSIS MALFUNCTION INDICATOR FAILURE CODES.....	5-13	O <sub>2</sub> SENSOR.....	5-69
PGM-FI TROUBLESHOOTING.....	5-16	KNOCK SENSOR.....	5-69
FUEL LINE INSPECTION.....	5-52	VEHICLE SPEED SENSOR.....	5-70
FUEL PUMP.....	5-54	ECM (ENGINE CONTROL MODULE).....	5-71
FUEL TANK.....	5-56	SECONDARY AIR SUPPLY SYSTEM.....	5-71
AIR CLEANER HOUSING.....	5-57	EVAPORATIVE EMISSION (EVAP) CONTROL SYSTEM.....	5-74
		ENGINE IDLE SPEED.....	5-75

# FUEL SYSTEM (Programmed Fuel Injection)

## COMPONENT LOCATION

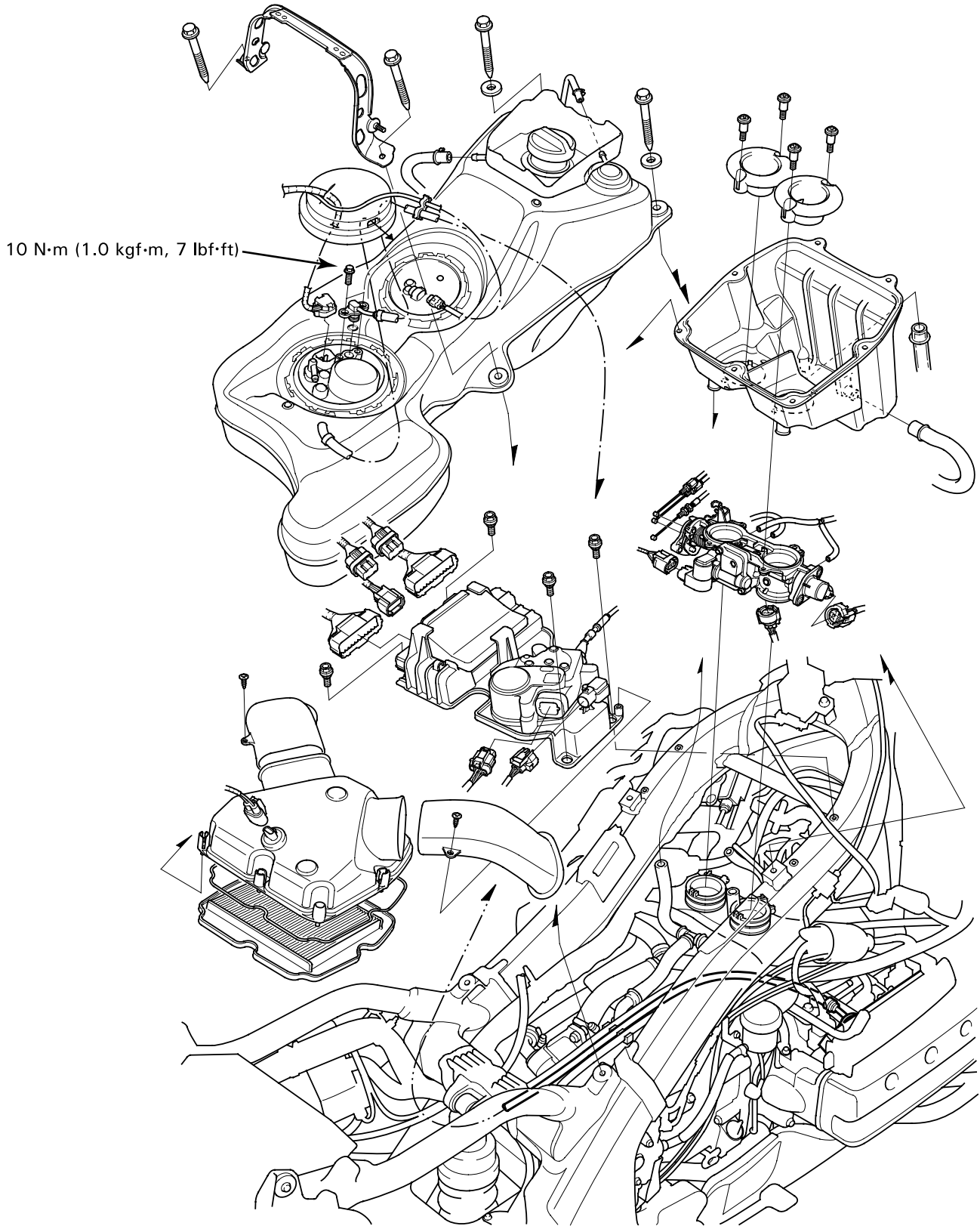

## **SERVICE INFORMATION**

### **GENERAL**

- Work in a well ventilated area. Smoking or allowing flames or sparks in the work area or where gasoline is stored can cause a fire or explosion.
- Be sure to relieve the fuel pressure with the ignition switch turned to "OFF."
- Bending or twisting the control cables will impair smooth operation and could cause the cables to stick or bind, resulting in loss of vehicle control.
- Do not apply commercially available carburetor cleaners to the inside of the throttle bore, which is coated with molybdenum.
- Do not snap the throttle valve from full open to full close after the throttle cable has been removed. It may cause incorrect idle operation.
- Seal the intake manifold ports with tape or a clean cloth to keep dirt and debris from entering the engine after the throttle body has been removed.
- Do not damage the throttle body. It may cause incorrect throttle and idle valve synchronization.
- Prevent dirt and debris from entering the air passages after the throttle body has been removed. Clean them using compressed air if necessary.
- The throttle body is factory pre-set. Do not disassemble in a way other than shown in this manual.
- Do not loosen or tighten the white painted bolts, nuts and screws of the throttle body. Loosening or tightening them can cause throttle and idle valve synchronization failure.
- Tighten the yellow painted bolts of the fuel rails to the specified torque.
- The parts of the throttle body not shown in this manual should not be disassembled.
- Always replace the O-ring when the fuel pump is removed.
- The PGM-FI (Programmed Fuel Injection) system is equipped with the self-diagnostic system described on page 5-8.
- When checking the PGM-FI system, always follow the steps in the troubleshooting flow chart (pages 5-16 through 5-55).
- The PGM-FI system is provided with a fail-safe function to secure a minimum running capability even when there is trouble in the system. When any abnormality is detected by the self-diagnosis function, running capability is maintained by preset value in the simulated program map. When any abnormality is detected in the injector(s), ignition pulse generator and/or camshaft position sensor, the fail-safe function stops the engine to protect it from damage.
- A faulty PGM-FI system is often related to poorly connected or corroded connections. Check those connections before proceeding.
- When disassembling the fuel system parts, note the location of the O-rings. Replace them with new ones upon reassembly.
- Always replace the sealing washer when the sealing bolt in the fuel rail is removed or loosened.
- Use a digital tester for PGM-FI system inspection.
- See section 17 for FI IGN relay inspection.
- See section 19 for the following components:
  - ECT sensor
  - fuel level sensor
  - gear position switch

### **SPECIFICATIONS**

<b>ITEM</b>	<b>SPECIFICATIONS</b>
Throttle body identification number	GQ61A
Throttle grip free play	2 – 6 mm (1/12 – 1/4)
Intake air temperature sensor resistance (20° C/68° F)	2.2 – 2.7 kΩ
Engine coolant temperature sensor resistance (20° C/68° F)	2.3 – 2.6 kΩ
Throttle position sensor resistance (20° C/68° F)	4 – 6 kΩ
Fuel injector resistance (20° C/68° F)	11.1 – 12.3 Ω
Camshaft position sensor peak voltage	0.7 V minimum
Ignition pulse generator peak voltage	0.7 V minimum
Manifold absolute pressure at idle	400 – 450 mm Hg (15.7 – 17.7 in Hg)
Fuel pressure at idle	343 kPa (3.5 kgf/cm <sup>2</sup> , 50 psi)
Fuel pump flow (at 12 V)	133 cm <sup>3</sup> (4.5 US oz, 4.7 Imp oz) minimum/10 seconds
Idle speed	700 ± 70 rpm

## FUEL SYSTEM (Programmed Fuel Injection)

### TORQUE VALUES

Fuel hose joint bolt	10 N·m (1.0 kgf·m, 7 lbf·ft)
Fuel rail mounting bolt	10 N·m (1.0 kgf·m, 7 lbf·ft)
Pressure regulator	27 N·m (2.8 kgf·m, 20 lbf·ft)
Pressure regulator stay bolt	10 N·m (1.0 kgf·m, 7 lbf·ft)
Fuel rail banjo bolt	33 N·m (3.4 kgf·m, 25 lbf·ft)
Sealing bolt	12 N·m (1.2 kgf·m, 9 lbf·ft)
PAIR check valve cover bolt	5 N·m (0.5 kgf·m, 3-6 lbf·ft)
Knock sensor	31 N·m (3.2 kgf·m, 23 lbf·ft)
O <sub>2</sub> sensor	25 N·m (2.5 kgf·m, 18 lbf·ft)

### TOOLS

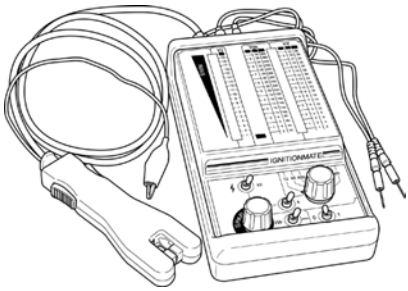
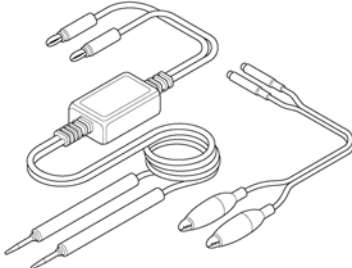
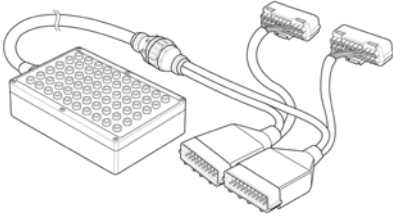
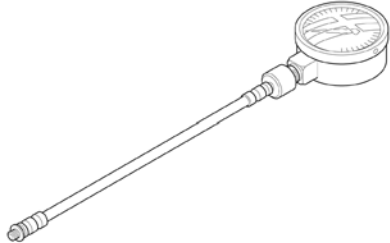
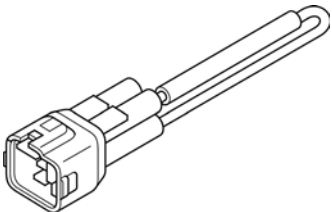
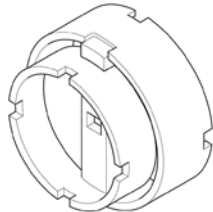
<p>IgnitionMate peak voltage tester MTP07-0286 (U.S.A. only)</p> 	<p>Peak voltage adaptor 07HGJ-0020100</p>  <p>(not available in U.S.A.) with commercially available digital multimeter (impedance 10 MΩ/DCV minimum)</p>	<p>Test harness set 07WMZ-MBGA000 (U.S.A. only)</p> 
<p>Fuel pressure gauge, 0 – 100 psi 07406-0040003</p>  <p>or 07406-004000B or 07406-004000A (U.S.A. only)</p>	<p>SCS service connector 070PZ-ZY30100</p> 	<p>Fuel sender/pump wrench 07ZMA-MCAA201 (U.S.A. only)</p>  <p>or 07ZMA-MCAA200 (U.S.A. only)</p>

## TROUBLESHOOTING

### Engine cranks but won't start

- No fuel in tank
- No fuel to injector
  - Clogged fuel filter
  - Pinched or clogged fuel feed hose
  - Pinched or clogged fuel tank breather tube
  - Faulty fuel pump
  - Faulty fuel pump circuits
- Intake air leak
- Contaminated/deteriorated fuel
- Faulty fuel injector
- Idle air control valve stuck closed
- No spark at plug (faulty ignition system – section 17)

### Engine stalls, hard to start, rough idling

- Restricted fuel feed hose
- Contaminated/deteriorated fuel
- Intake air leak
- Faulty idle air control valve
- Restricted fuel tank breather tube
- Misadjusted idle adjusting screw
- Faulty ignition system (section 17)

### Afterburn when engine braking is used

- Faulty pulse secondary air injection (PAIR) system
  - Faulty PAIR control solenoid valve
  - Faulty PAIR check valve
  - Clogged hose of the PAIR system
- Faulty ignition system (section 17)

### Backfiring or misfiring during acceleration

- Faulty ignition system (section 17)

### Poor performance (driveability) and poor fuel economy

- Pinched or clogged fuel feed hose
- Faulty pressure regulator
- Faulty ignition system (section 17)

# FUEL SYSTEM (Programmed Fuel Injection)

## SYSTEM LOCATION

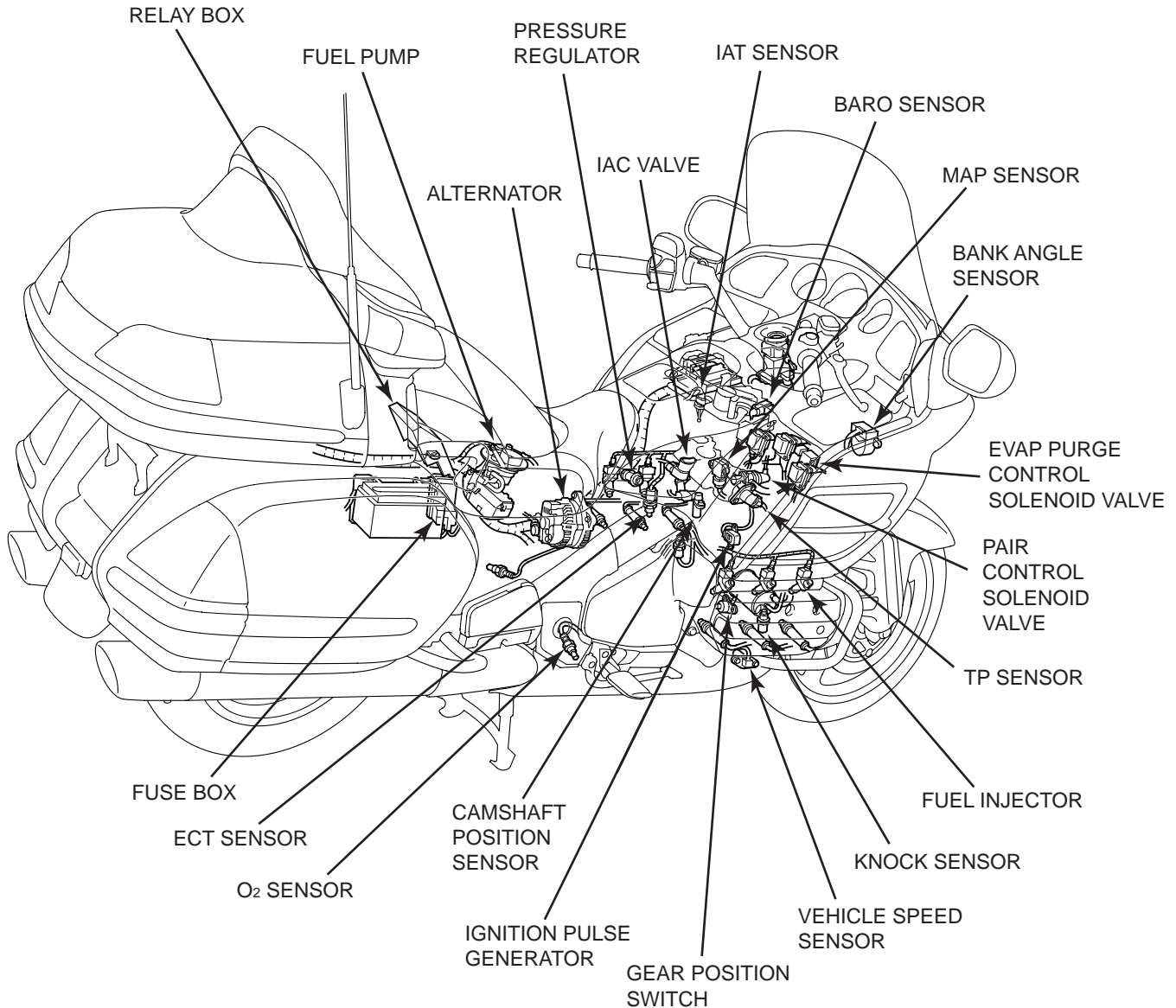

FULL NAME	ABBREVIATIONS
Barometric pressure sensor	BARO sensor
Engine control module	ECM
Engine coolant temperature sensor	ECT sensor
Idle air control valve	IAC valve

FULL NAME	ABBREVIATIONS
Intake air temperature sensor	IAT sensor
Manifold absolute pressure sensor	MAP sensor
Oxygen sensor	O <sub>2</sub> sensor
Throttle position sensor	TP sensor

SYSTEM DIAGRAM

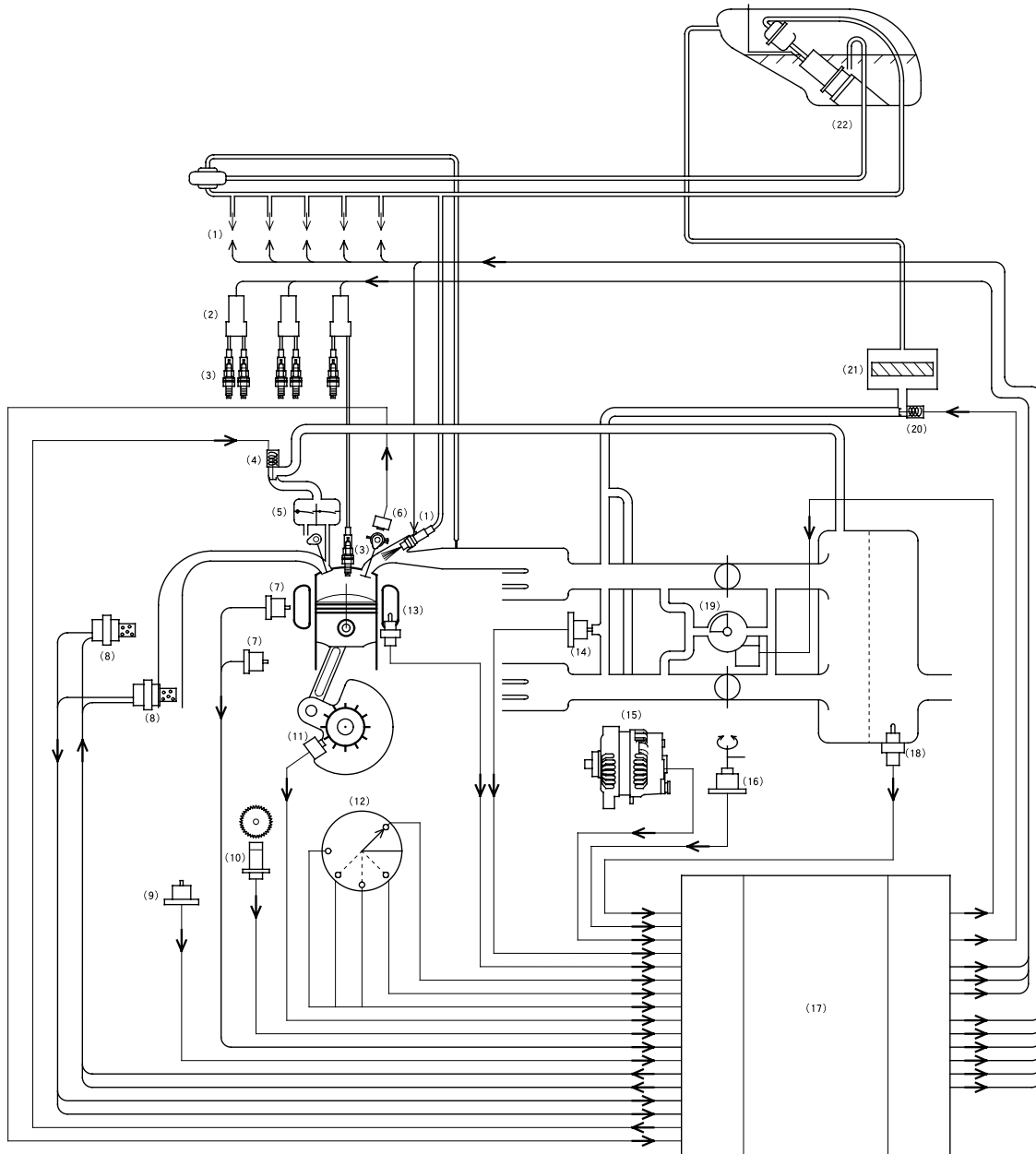

- |   |   |
|---|---|
| (1) Fuel injectors                                    | (13) ECT sensor   |
| (2) Ignition coils                                    | (14) MAP sensor   |
| (3) Spark plugs                                       | (15) Alternator   |
| (4) Pulse secondary air (PAIR) control solenoid valve | (16) TP sensor  |
| (5) PAIR check valve                                  | (17) ECM  |
| (6) Camshaft position sensor                          | (18) IAT sensor   |
| (7) Knock sensors                                     | (19) IAC valve  |
| (8) O <sub>2</sub> sensors                            | (20) Evaporative emission (EVAP) control solenoid valve |
| (9) BARO sensor                                       | (21) EVAP canister                                      |
| (10) Vehicle speed sensor                             | (22) Fuel pump  |
| (11) Ignition pulse generator                         |   |
| (12) Gear position switch                             |   |



## FUEL SYSTEM (Programmed Fuel Injection)

# PGM-FI (PROGRAMMED FUEL INJECTION) SYSTEM

### SELF-DIAGNOSTIC DATA INDICATION PROCEDURE

Place the motorcycle on its side stand.

Turn the ignition switch to "ON" and engine stop switch to "O".

The malfunction indicator lamp (MIL) comes on for a few seconds, then goes off.

Start the engine and let it idle.

- If the engine will not start, turn the starter motor for more than 10 seconds and check that the MIL blinks

If the MIL does not blink, the ECM has no problem data.

If the MIL blinks, read and record how many times the MIL blinks, and determine the cause of the problem (pages 5-13 through 5-55).

#### NOTE:

- The MIL will start blinking when the side stand is lowered and the engine speed is below 1,500 rpm. If the side stand is retracted or the engine speed is above 1,500 rpm, the MIL will illuminate and stay on.

To read the ECM memory of problem data, perform the following:

Turn the ignition switch to "OFF."

Remove the seat (page 2-5).

'01 - '03:

Short the service check connector terminals with a jumper wire.

After '03:

Remove the dummy connector and short the Brown and Green wire terminals of the Data Link Connector (DLC) using the special tool.

#### TOOL:

**SCS service connector**                      **070PZ-ZY30100**

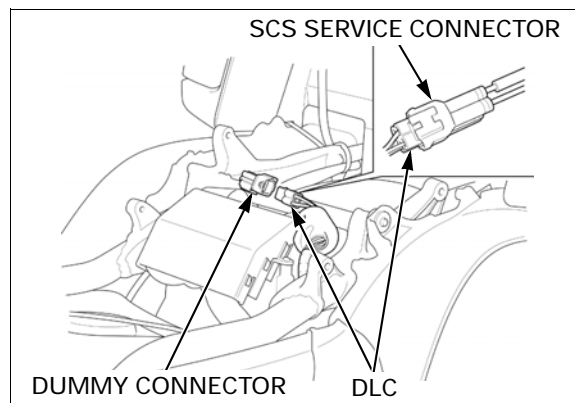
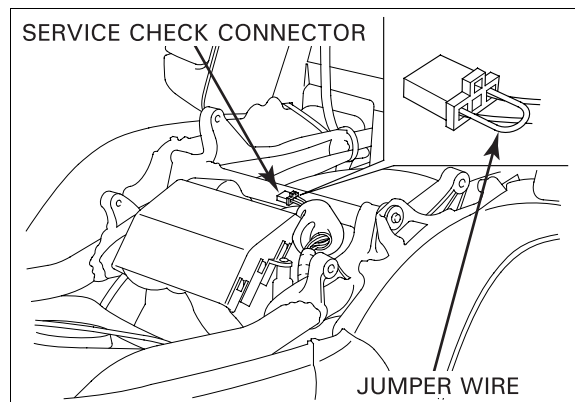
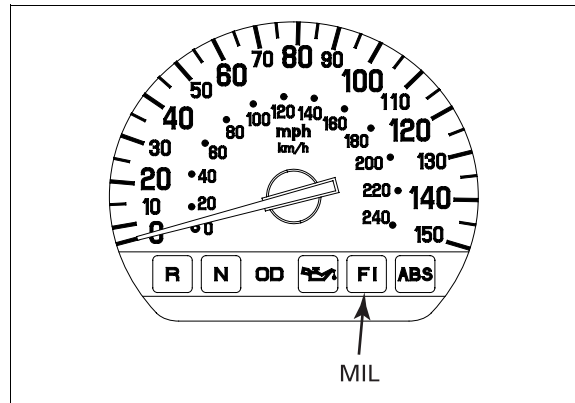

Make sure the engine stop switch is turned to "O."

Turn the ignition switch to "ON."

If the ECM has no problem data in its memory, the MIL will come on and stay on.

If the ECM has problem data in its memory, the MIL will start blinking.

Read and record how many times the MIL blinks, and determine the cause of the problem (pages 5-13 through 5-55).

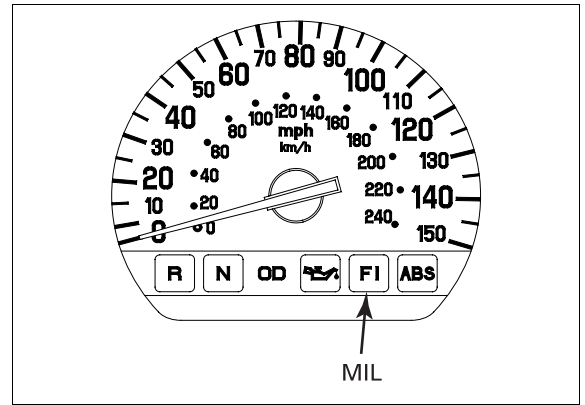

### SELF-DIAGNOSTIC MEMORY RESET PROCEDURE

Remove the seat (page 2-5).

Place the side stand down.

'01 - '03:

1. Turn the ignition switch to "OFF."
2. Short the service check connector terminals (3P black connector with green and black leads) with a jumper wire.
3. Turn the ignition switch to "ON."
4. Remove the jumper wire from the service check connector.

Make sure the engine stop switch is turned to "O."

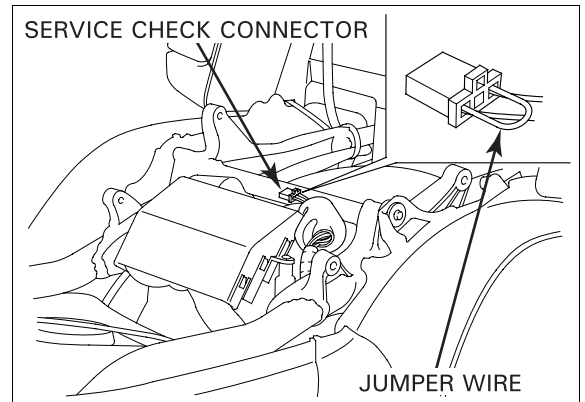

5. The MIL will light for approximately 5 seconds. While the MIL lights, short the service check connector terminals again with the jumper wire. The self-diagnostic memory is erased if the malfunction indicator goes off and starts blinking.

NOTE:

- The service check connector must be jumped while the MIL lights. If not, the MIL will not start blinking.
- Note that the self-diagnostic memory cannot be erased if the ignition switch is turned "OFF" before the MIL starts blinking.

If the MIL blinks 33 times, the self-diagnostic memory has not been erased.

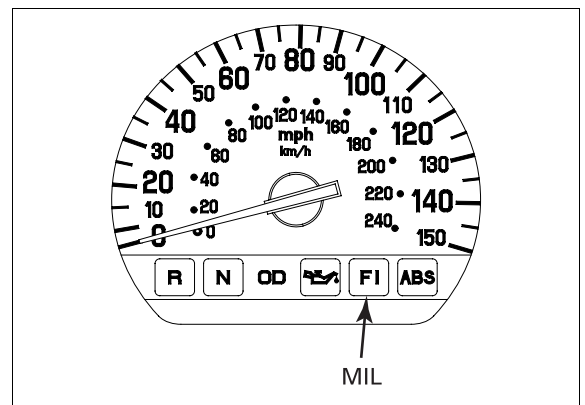

## FUEL SYSTEM (Programmed Fuel Injection)

### After '03:

1. Turn the ignition switch to "OFF."
2. Remove the dummy connector and short the Brown and Green wire terminals of the Data Link Connector (DLC) using the special tool.

*Make sure the engine stop switch is turned to "O."*

### TOOL:

**SCS service connector      070PZ-ZY30100**

3. Turn the ignition switch to "ON."
4. Remove the special tool wire from the DLC.

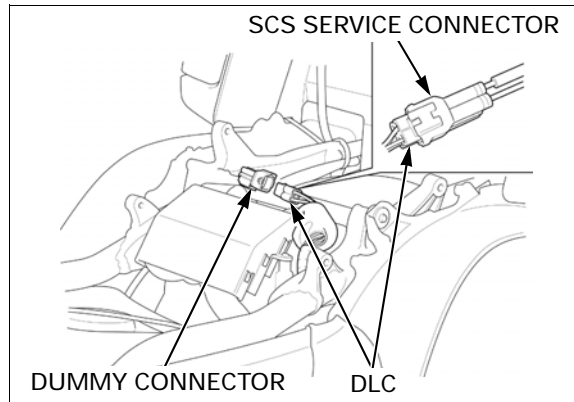

5. The MIL will light for approximately 5 seconds. While the MIL lights, short the DLC terminals again with the special tool. The self-diagnostic memory is erased if the malfunction indicator goes off and starts blinking.

### NOTE:

- The DLC must be jumped while the MIL lights. If not, the MIL will not start blinking.
- Note that the self-diagnostic memory cannot be erased if the ignition switch is turned "OFF" before the MIL starts blinking.

If the MIL blinks 33 times, the self-diagnostic memory has not been erased.

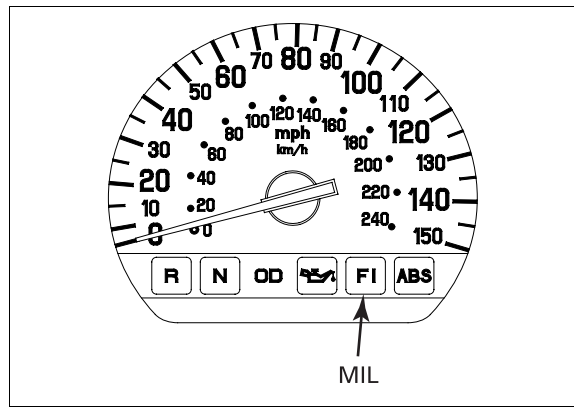

## PEAK VOLTAGE INSPECTION PREPARATION

### NOTE:

- Use this procedure for the ignition pulse generator and camshaft position sensor inspection.
- Use a commercially available digital multimeter (impedance 10 M /DCV minimum).
- The display value differs depending upon the internal impedance of the multimeter.
- Check the cylinder compression of each cylinder and check that each spark plug is installed correctly.

Remove the seat (page 2-5).

Disconnect the fuel pump 5P connector.

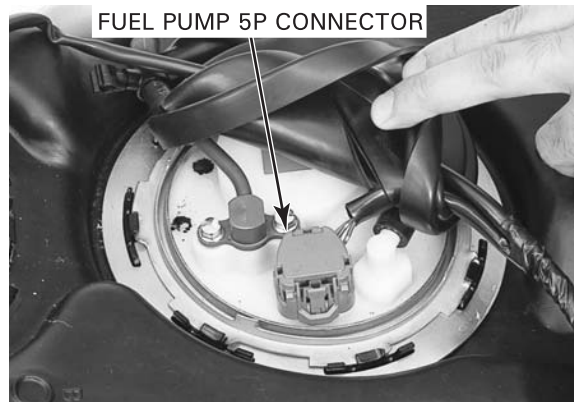

## FUEL SYSTEM (Programmed Fuel Injection)

Connect the peak voltage adaptor to the digital multimeter.

### TOOLS:

**Ignitionmate Peak voltage tester** MTP07-0286 (U.S.A. only) or

**Peak voltage adaptor with commercially available digital multimeter (impedance 10 M $\Omega$ /DCV minimum)** 07HGJ-0020100 (not available in U.S.A.)

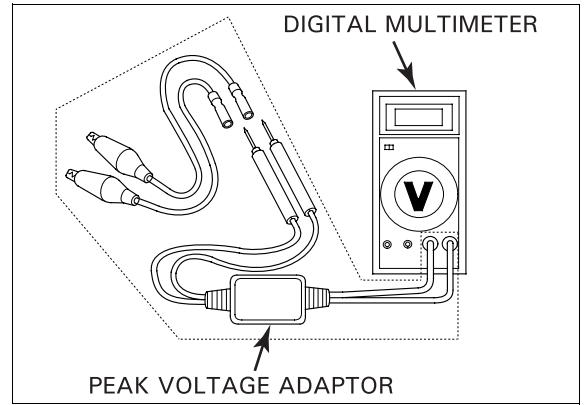

### TEST HARNESS CONNECTION

Remove the top shelter (page 2-12).

Turn the ignition switch to "OFF."

*Do not disconnect the 6P black connector from the ECM.*

Disconnect the 22P black and gray connectors from the ECM.

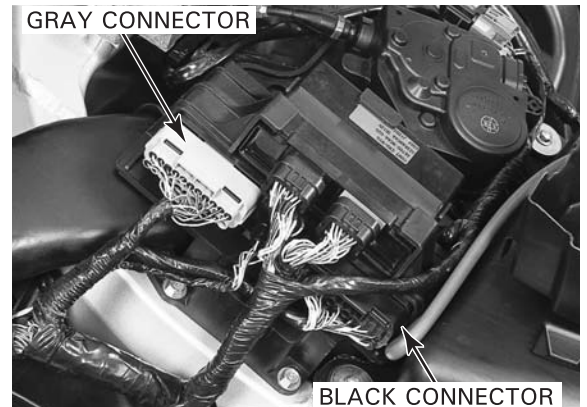

Connect the test harness set to the ECM and ECM connectors.

### TOOL:

**Test harness set** 07WMZ-MBGA000

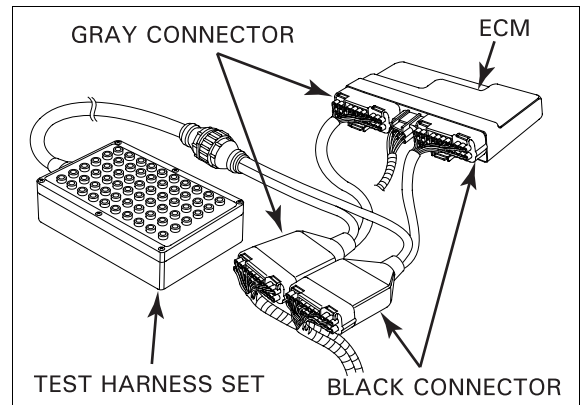

### TEST PIN BOX TERMINAL LAYOUT

The ECM connector terminals are numbered as shown.

Terminals No. 1 to No. 22 of the test pin box of the test harness are for terminals C1 to C22 of the ECM black connector.

Terminals No. 31 to No. 52 of the test pin box of the test harness are for terminals B1 to B22 of the ECM gray connector.

Example:

ECM terminals: B8 (+) – C8 (-)

Test pin box terminals: No. 38 – No. 8

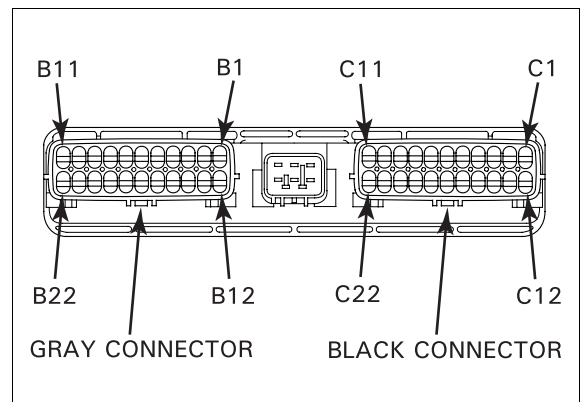

# FUEL SYSTEM (Programmed Fuel Injection)

## Terminal Conversion Chart

22P black connector terminal No.	Test pin box terminal No.
C1	1
C2	2
↓	↓
C21	21
C22	22
22P gray connector terminal No.	Test pin box terminal No.
B1	31
B2	32
↓	↓
B21	51
B22	52

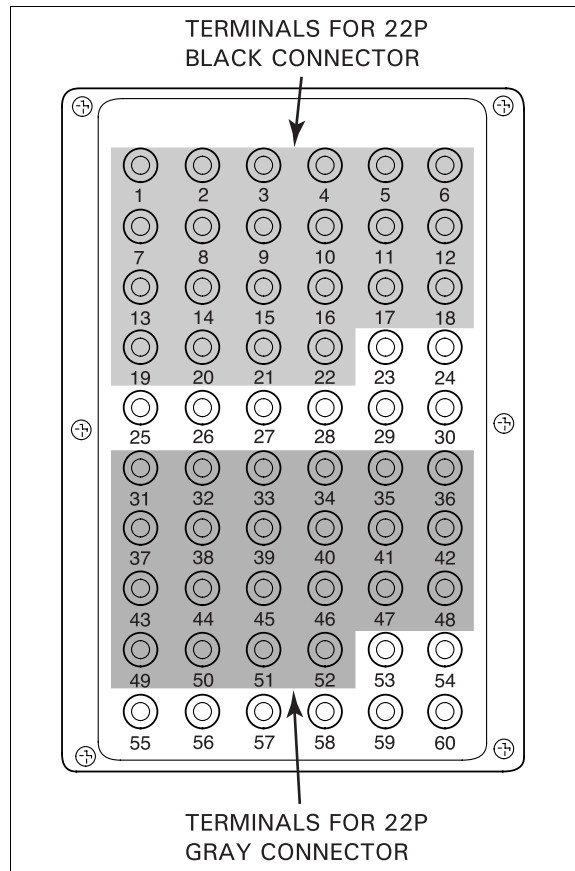

## MALFUNCTION INDICATOR LAMP (MIL) CHECK

If the engine can be started but the MIL does not come on when the ignition switch is turned "ON" and the engine stop switch is in "O," check as follows:

Check the oil pressure and side stand indicators function properly.

- If they do not function, check the combination meter power input line (page 20-17).
- If they function properly, check as follows:

Remove the top shelter (page 2-12).

Turn the ignition switch to "OFF," disconnect the ECM 22P black connector.







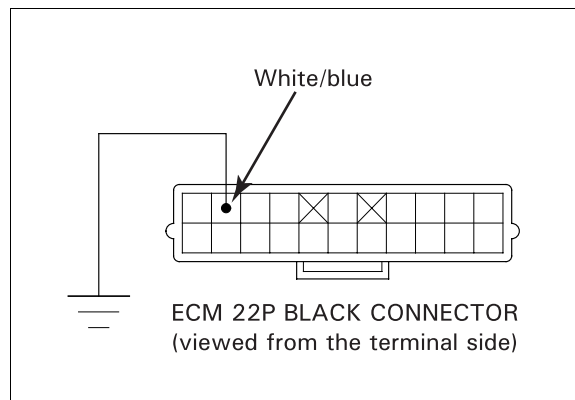



Ground the White/blue wire terminal of the wire harness side connector with a jumper wire. Turn the ignition switch to "ON," the MIL should come on.

- If the MIL comes on, replace the ECM.
- If the MIL does not come on, check for open circuit in the White/blue wire between the combination meter and ECM. If the wire is OK, replace the combination meter.



## PGM-FI SELF-DIAGNOSIS MALFUNCTION INDICATOR FAILURE CODES







- The PGM-FI malfunction indicator lamp (MIL) denotes the failure codes (the number of blinks from 0 to 41). The MIL has two types of blinks, a long blink and short blink. The long blink lasts for 1.3 seconds, the short blink lasts for 0.5 seconds. When a long blink occurs, that counts for 10 blinks of the MIL. The short blink counts for one MIL blink. Therefore, if the MIL blinks two long blinks, and one short blink, that problem code is 21 (two long blinks = 20 blinks, one short blink = 1 blink). Then, go to the flow chart and see problem code 21.
- When the Engine Control Module (ECM) stores some failure codes, the MIL shows the failure codes in the order from the lowest number to highest number. For example, when the MIL blinks once, then blinks seven times, two failures have occurred. Follow the flow charts for failure codes 1 and 7.

Number of MIL blinks		Cause	Symptoms (Fail-safe contents)	Refer to page
0	 No blinks	<ul style="list-style-type: none"> <li>• Open circuit in the power input and ground wires of the ECM</li> <li>• Faulty bank angle sensor</li> <li>• Open circuit in bank angle sensor related wires</li> <li>• Faulty FI IGN relay</li> <li>• Open circuit in FI IGN relay related wires</li> <li>• Faulty engine stop switch</li> <li>• Open circuit in engine stop switch related wires</li> <li>• Faulty ECM</li> <li>• Blown FI IGN fuse (20 A)</li> <li>• Blown ST. KILL fuse (10 A)</li> </ul>	<ul style="list-style-type: none"> <li>• Engine does not start</li> </ul>	5-71
	 No blinks	<ul style="list-style-type: none"> <li>• Open circuit in MIL wire</li> <li>• Faulty combination meter</li> <li>• Faulty ECM</li> </ul>	<ul style="list-style-type: none"> <li>• Engine operates normally</li> </ul>	5-12
	 Stays lit	<ul style="list-style-type: none"> <li>• Short circuit in service check connector wire</li> <li>• Short circuit in MIL wire</li> <li>• Faulty ECM</li> </ul>	<ul style="list-style-type: none"> <li>• Engine operates normally</li> </ul>	-
1	 Blinks	<ul style="list-style-type: none"> <li>• Loose or poorly connected MAP sensor connector</li> <li>• Open or short circuit in MAP sensor wire</li> <li>• Faulty MAP sensor</li> </ul>	<ul style="list-style-type: none"> <li>• Engine operates normally</li> </ul>	5-16
7	 Blinks	<ul style="list-style-type: none"> <li>• Loose or poorly connected ECT sensor connector</li> <li>• Open or short circuit in ECT sensor wire</li> <li>• Faulty ECT sensor</li> </ul>	<ul style="list-style-type: none"> <li>• Hard to start at a low temperature (ECM controls using preset value; coolant temperature: 85°C/185°F)</li> </ul>	5-18
8	 Blinks	<ul style="list-style-type: none"> <li>• Loose or poorly connected TP sensor connector</li> <li>• Open or short circuit in TP sensor wire</li> <li>• Faulty TP sensor</li> </ul>	<ul style="list-style-type: none"> <li>• Poor engine response when operating the throttle quickly (ECM controls using preset value; throttle opening: 0°)</li> </ul>	5-19
9	 Blinks	<ul style="list-style-type: none"> <li>• Loose or poorly connected IAT sensor connector</li> <li>• Open or short circuit in TP sensor wire</li> <li>• Faulty IAT sensor</li> </ul>	<ul style="list-style-type: none"> <li>• Engine operates normally (ECM controls using preset value; intake air temperature: 28°C/82°F)</li> </ul>	5-22
10	 Blinks	<ul style="list-style-type: none"> <li>• Loose or poorly connected BARO sensor connector</li> <li>• Open or short circuit in BARO sensor wire</li> <li>• Faulty BARO sensor</li> </ul>	<ul style="list-style-type: none"> <li>• Engine operates normally at low altitude</li> <li>• Engine idles roughly at a high altitude (ECM controls using preset value; barometric pressure: 760 mm Hg/1,013 hPa)</li> </ul>	5-23

## FUEL SYSTEM (Programmed Fuel Injection)

Number of MIL blinks		Cause	Symptoms (Fail-safe contents)	Refer to page
11	 Blinks	<ul style="list-style-type: none"> <li>Loose or poorly connected vehicle speed sensor connector</li> <li>Open or short circuit in vehicle speed sensor wire</li> <li>Faulty vehicle speed sensor</li> </ul>	<ul style="list-style-type: none"> <li>Engine operates normally</li> </ul>	5-24
12	 Blinks	<ul style="list-style-type: none"> <li>Loose or poorly connected No. 1 injector connector</li> <li>Open or short circuit in No. 1 injector wire</li> <li>Faulty No. 1 injector</li> </ul>	<ul style="list-style-type: none"> <li>Engine does not start</li> </ul>	5-26
13	 Blinks	<ul style="list-style-type: none"> <li>Loose or poorly connected No. 2 injector connector</li> <li>Open or short circuit in No. 2 injector wire</li> <li>Faulty No. 2 injector</li> </ul>	<ul style="list-style-type: none"> <li>Engine does not start</li> </ul>	5-27
14	 No blinks	<ul style="list-style-type: none"> <li>Loose or poorly connected No. 3 injector connector</li> <li>Open or short circuit in No. 3 injector wire</li> <li>Faulty No. 3 injector</li> </ul>	<ul style="list-style-type: none"> <li>Engine does not start</li> </ul>	5-28
15	 Blinks	<ul style="list-style-type: none"> <li>Loose or poorly connected No. 4 injector connector</li> <li>Open or short circuit in No. 4 injector wire</li> <li>Faulty No. 4 injector</li> </ul>	<ul style="list-style-type: none"> <li>Engine does not start</li> </ul>	5-30
16	 Blinks	<ul style="list-style-type: none"> <li>Loose or poorly connected No. 5 injector connector</li> <li>Open or short circuit in No. 5 injector wire</li> <li>Faulty No. 5 injector</li> </ul>	<ul style="list-style-type: none"> <li>Engine does not start</li> </ul>	5-31
17	 Blinks	<ul style="list-style-type: none"> <li>Loose or poorly connected No. 6 injector connector</li> <li>Open or short circuit in No. 6 injector wire</li> <li>Faulty No. 6 injector</li> </ul>	<ul style="list-style-type: none"> <li>Engine does not start</li> </ul>	5-33
18	 Blinks	<ul style="list-style-type: none"> <li>Loose or poorly connected camshaft position sensor connector</li> <li>Open or short circuit in camshaft position sensor wire</li> <li>Faulty camshaft position sensor</li> </ul>	<ul style="list-style-type: none"> <li>Engine does not start</li> </ul>	5-34
19	 Blinks	<ul style="list-style-type: none"> <li>Loose or poorly connected ignition pulse generator connector</li> <li>Open or short circuit in ignition pulse generator wire</li> <li>Faulty ignition pulse generator</li> </ul>	<ul style="list-style-type: none"> <li>Engine does not start</li> </ul>	5-36
21	 Blinks	<ul style="list-style-type: none"> <li>Open or short circuit in right O<sub>2</sub> sensor wire</li> <li>Faulty right O<sub>2</sub> sensor</li> </ul>	<ul style="list-style-type: none"> <li>Engine operates normally</li> </ul>	5-37
22	 Blinks	<ul style="list-style-type: none"> <li>Open or short circuit in left O<sub>2</sub> sensor wire</li> <li>Faulty left O<sub>2</sub> sensor</li> </ul>	<ul style="list-style-type: none"> <li>Engine operates normally</li> </ul>	5-39
23	 Blinks	<ul style="list-style-type: none"> <li>Open or short circuit in right O<sub>2</sub> sensor heater wire</li> <li>Faulty right O<sub>2</sub> sensor</li> </ul>	<ul style="list-style-type: none"> <li>Engine operates normally</li> </ul>	5-40

## FUEL SYSTEM (Programmed Fuel Injection)

Number of MIL blinks		Cause	Symptoms (Fail-safe contents)	Refer to page
24	 Blinks	<ul style="list-style-type: none"> <li>• Open or short circuit in left O<sub>2</sub> sensor heater wire</li> <li>• Faulty left O<sub>2</sub> sensor</li> </ul>	<ul style="list-style-type: none"> <li>• Engine operates normally</li> </ul>	5-42
25	 Blinks	<ul style="list-style-type: none"> <li>• Loose or poorly connected right knock sensor connector</li> <li>• Open or short circuit in right knock sensor wire</li> <li>• Faulty right knock sensor</li> </ul>	<ul style="list-style-type: none"> <li>• Engine operates normally</li> </ul>	5-43
26	 Blinks	<ul style="list-style-type: none"> <li>• Loose or poorly connected left knock sensor connector</li> <li>• Open or short circuit in left knock sensor wire</li> <li>• Faulty left knock sensor</li> </ul>	<ul style="list-style-type: none"> <li>• Engine operates normally</li> </ul>	5-44
29	 Blinks	<ul style="list-style-type: none"> <li>• Loose or poorly connected idle air control (IAC) valve connector</li> <li>• Open or short circuit in IAC valve wire</li> <li>• Faulty idle air control valve</li> </ul>	<ul style="list-style-type: none"> <li>• Engine stalls, hard to start, rough idling</li> </ul>	5-45
33	 Blinks	<ul style="list-style-type: none"> <li>• Faulty E<sup>2</sup>-PROM in ECM</li> </ul>	<ul style="list-style-type: none"> <li>• Engine operates normally</li> <li>• ECM does not hold the self-diagnostic data</li> </ul>	5-48
41	 No blinks	<ul style="list-style-type: none"> <li>• Loose or poorly connected connector in gear position switch related circuits</li> <li>• Open or short circuit in gear position switch wires</li> <li>• Faulty gear position switch</li> <li>• Faulty clutch switch</li> <li>• Faulty side stand switch</li> </ul>	<ul style="list-style-type: none"> <li>• Engine operates normally</li> </ul>	5-49



# PGM-FI TROUBLESHOOTING

### MIL 1 BLINK (MAP SENSOR)

#### 1. MAP Sensor Power Input Line Voltage Inspection

Remove the top shelter (page 2-12).

Turn the ignition switch to "OFF."

Disconnect the engine sub-wire harness 8P connector.

Check the connector for loose contacts or corroded terminals.

Turn the ignition switch to "ON."

Measure the voltage between the main wire harness side 8P gray connector terminal and ground.

**Connection: Yellow/red (+) – Ground (-)**

**Standard: 4.75 – 5.25 V**

**Is the voltage within 4.75 – 5.25 V?**

**NO** – • Open or short circuit in the Yellow/red wire of the main wire harness.  
• Loose or poorly connected ECM black connector.

**YES** – GO TO STEP 2.

#### 2. MAP Sensor Line Voltage Inspection

Measure the voltage between the main wire harness side 8P gray connector terminals.

**Connection: Yellow/red (+) – Green/red (-)**

**Standard: 4.75 – 5.25 V**

**Is the voltage within 4.75 – 5.25 V?**

**NO** – • Open circuit in the Green/red wire of the main wire harness.  
• Loose or poorly connected ECM black connector.

**YES** – GO TO STEP 3.

#### 3. MAP Sensor Line Voltage Inspection

Measure the voltage between the main wire harness side 8P gray connector terminals.

**Connection: Light green/yellow (+) – Green/red (-)**

**Standard: 4.75 – 5.25 V**

**Is the voltage within 4.75 – 5.25 V?**

**NO** – Open or short circuit in the Light green/yellow wire of the main wire harness.

**YES** – GO TO STEP 4.

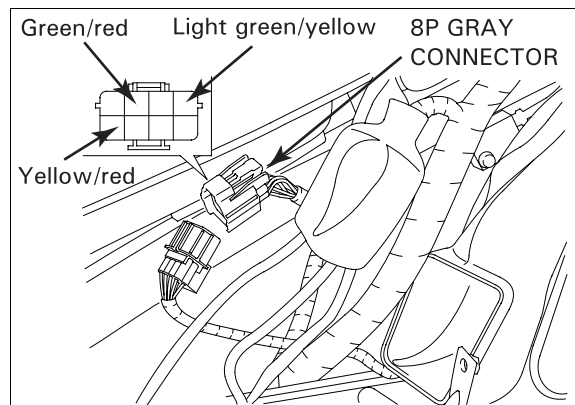

### 4. MAP Sensor Harness Continuity Inspection

Turn the ignition switch to "OFF."  
 Remove the air cleaner housing (page 5-57).  
 Disconnect the MAP sensor 3P connector.  
 Check the connector for loose contacts or corroded terminals.  
 Check for continuity of the following wires between the 8P gray connector and MAP sensor 3P connector.

- Yellow/red
- Green/red
- Light green/yellow

**Is there continuity?**

- NO** – • Open circuit in the following wires of the engine sub-wire harness:
- Yellow/red
  - Green/red
  - Light green/yellow

**YES** – GO TO STEP 5.

### 5. MAP Sensor Harness Short Circuit Inspection

Check for continuity between the following wire terminal and ground at the wire harness side MAP sensor 3P connector.

- Yellow/red
- Green/red
- Light green/yellow

**Is there continuity?**

- YES** – • Short circuit in the following wires of the engine sub-wire harness:
- Yellow/red
  - Green/red
  - Light green/yellow

**NO** – GO TO STEP 6.

### 6. MAP Sensor Voltage at ECM

Connect the MAP sensor 3P connector and engine sub-wire harness 8P gray connector.  
 Install the air cleaner housing (page 5-57).  
 Connect the test harness set to the ECM connectors (page 5-11).  
 Turn the ignition switch to "ON."  
 Measure the voltage at the test pin box terminals.

**Connection: No. 38 (+) – No. 8 (–)**

**Standard: 2.7 – 3.1 V (at 760 mm Hg/1,013 hPa)**

**Is the voltage within 2.7 – 3.1 V (at 760 mm Hg/1,013 hPa)?**

**NO** – Faulty MAP sensor.

**YES** – GO TO STEP 7.

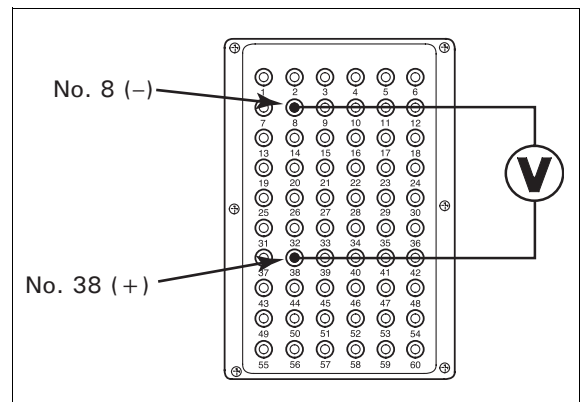
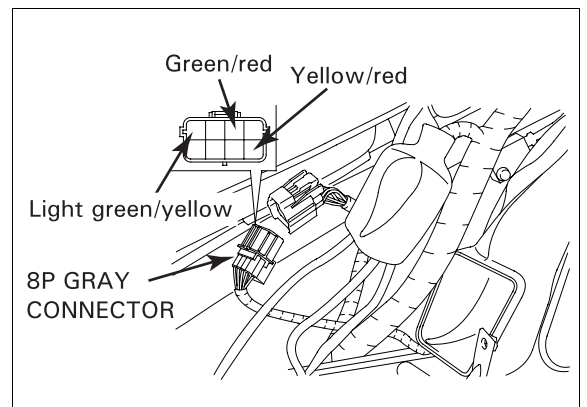
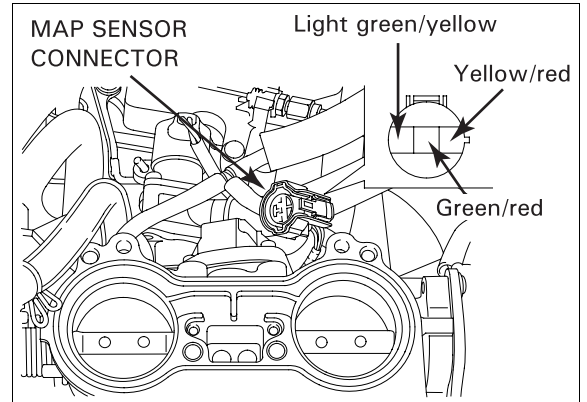

## FUEL SYSTEM (Programmed Fuel Injection)

### 7. MAP Sensor Connection Inspection

Turn the ignition switch to "OFF."  
Remove the test harnesses and connect the ECM connectors.  
Place the motorcycle on its side stand.  
Start the engine, let it idle and check that the MIL blinks.

#### *Is the MIL blinking?*

- NO** – Temporary failure; the system is normal.
- YES** – Replace the ECM with a new one and inspect again.

### MIL 7 BLINKS (ECT SENSOR)

#### 1. ECT Sensor Input Line Voltage Inspection

Remove the left radiator stay (page 5-61).  
Turn the ignition switch to "OFF."

Disconnect the ECT sensor 3P connector.  
Check the connector for loose contacts or corroded terminals.

Turn the ignition switch to "ON."  
Measure the voltage between the wire harness side 3P connector terminal and ground.

**Connection: Yellow/blue (+) – Ground (-)**  
**Standard: 4.75 – 5.25 V**

#### *Is the voltage within 4.75 – 5.25 V?*

- NO** –
- Open or short circuit in the Yellow/blue wire.
  - Loose or poorly connected ECM gray connector or engine sub-wire harness 6P connector.

**YES** – GO TO STEP 2.

#### 2. ECT Sensor Line Voltage Inspection

Measure the voltage between the wire harness side 3P connector terminals.

**Connection: Yellow/blue (+) – Green/red (-)**  
**Standard: 4.75 – 5.25 V**

#### *Is the voltage within 4.75 – 5.25 V?*

- NO** –
- Open circuit in the Green/red wire.
  - Loose or poorly connected ECM black connector or engine sub-wire harness 6P connector.

**YES** – GO TO STEP 3.

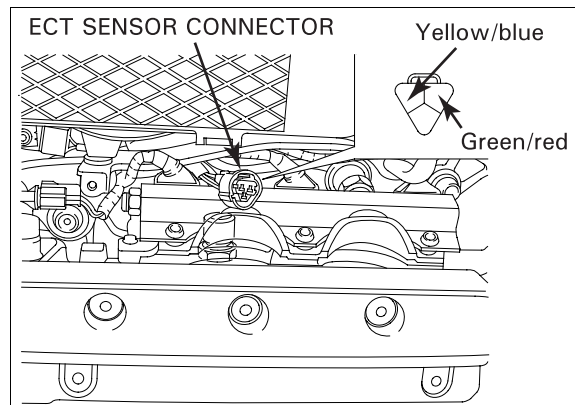

### 3. ECT Sensor Resistance Inspection

Turn the ignition switch to "OFF."  
Connect the ECT sensor 3P connector.  
Disconnect the engine sub-wire harness 6P gray connector.  
Check the connector for loose contacts or corroded terminals.

Measure the resistance between the engine sub-wire harness side 6P gray connector terminals.

**Connection: Yellow/blue – Green/red**

**Standard: 2.2 – 2.7 k (at 20° C/68° F)**

***Is the resistance within 2.2 – 2.7 k (at 20° C/68° F)?***

**NO** – Faulty ECT sensor.

**YES** – GO TO STEP 4.

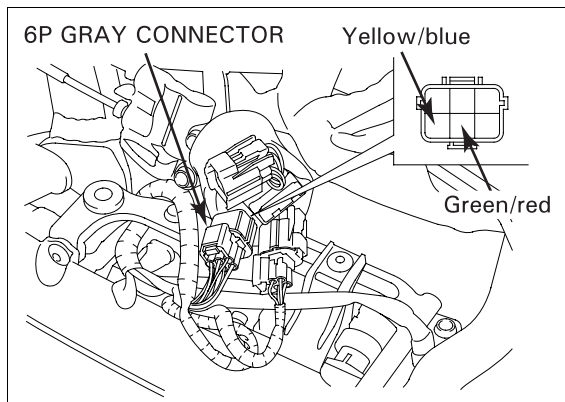

### 4. ECT Sensor Connection Inspection

Connect the engine sub-wire harness 6P gray connector.

Place the motorcycle on its side stand.

Turn the ignition switch to "ON."

Check that the MIL blinks.

***Is the MIL blinking?***

**NO** – Temporary failure; the system is normal.

**YES** – Replace the ECM with a new one and inspect again.

## MIL 8 BLINKS (TP SENSOR)

### 1. TP Sensor Input Voltage Inspection

Remove the top shelter (page 2-12).

Turn the ignition switch to "OFF."

Disconnect the engine sub-wire harness 8P gray connector.

Check the connector for loose contacts or corroded terminals.

Turn the ignition switch "ON."

Measure the voltage between the main wire harness side 8P gray connector terminal and ground.

**Connection: Yellow/red (+) – Ground (-)**

**Standard: 4.75 – 5.25 V**

***Is the voltage within 4.75 – 5.25 V?***

**NO** – • Open or short circuit in the Yellow/red wire of the main wire harness.  
• Loose or poorly connected ECM black connector.

**YES** – GO TO STEP 2.

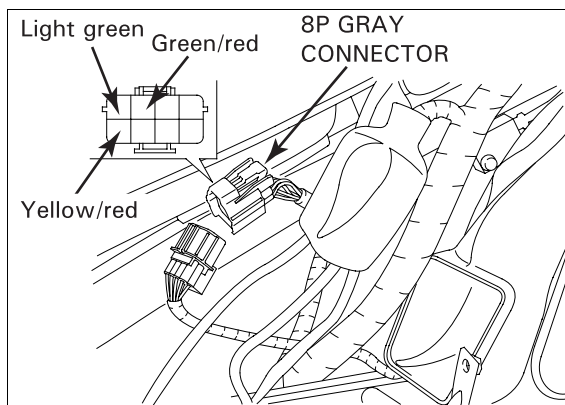

## FUEL SYSTEM (Programmed Fuel Injection)

### 2. TP Sensor Input Voltage Inspection

Measure the voltage between the main wire harness side 8P gray connector terminals.

**Connection: Yellow/red (+) – Green/red (–)**

**Standard: 4.75 – 5.25 V**

***Is the voltage within 4.75 – 5.25 V?***

**NO** – • Open circuit in the Green/red wire of the main wire harness.  
• Loose or poorly connected ECM black connector.

**YES** – GO TO STEP 3.

### 3. TP Sensor Line Short Circuit Inspection

Turn the ignition switch to “OFF.”  
Disconnect the ECM 22P gray connector.  
Check for continuity between Light green wire terminal of the main wire harness side 8P gray connector and ground.

***Is there continuity?***

**YES** – Short circuit in the Light green wire of the main wire harness.

**NO** – GO TO STEP 4.

### 4. TP Sensor Line Continuity Inspection

Check for continuity between Light green wire terminals of the 8P gray connector and ECM 22P connector.

***Is there continuity?***

**NO** – Open circuit in the Light green wire of the main wire harness.

**YES** – GO TO STEP 5.

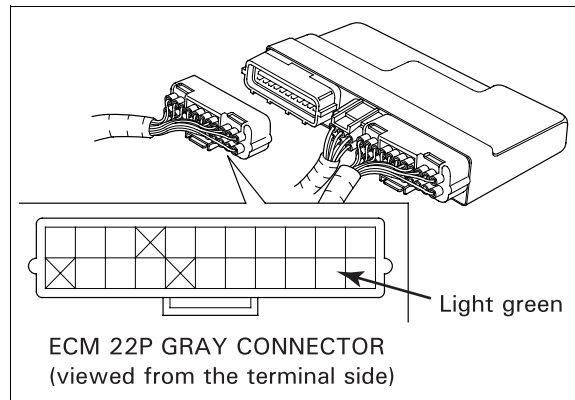

### 5. TP Sensor Harness Continuity Inspection

Turn the ignition switch to “OFF.”  
Remove the air cleaner housing (page 5-57).

Disconnect the TP sensor 3P connector.  
Check the connector for loose contacts or corroded terminals.

Check for continuity of the following wires between the 8P connector and TP sensor 3P connector.

- Yellow/red
- Green/red
- Light green

***Is there continuity?***

**NO** – Open circuit in the following wires of the engine sub-wire harness:  
– Yellow/red  
– Green/red  
– Light green

**YES** – GO TO STEP 6.

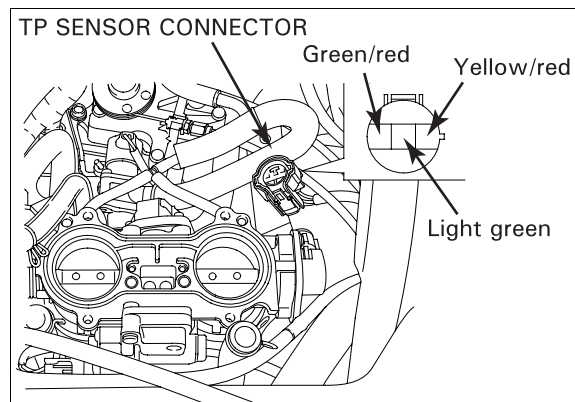

### 6. TP Sensor Harness Short Circuit Inspection

Check for continuity between the following wire terminal and ground at the wire harness side TP sensor 3P connector.

- Yellow/red
- Green/red
- Light green

**Is there continuity?**

**YES** – Short circuit in the following wires of the engine sub-wire harness:

- Yellow/red
- Green/red
- Light green

**NO** – GO TO STEP 7.

### 7. TP Sensor Voltage at ECM

Connect the TP sensor 3P connector and engine sub-wire harness 8P connector.

Install the air cleaner housing (page 5-57).

Connect the test harness set to the ECM connectors (page 5-11).

Turn the ignition switch to "ON."

Measure the voltage at the test pin box terminals.

**Connection: No. 51 (+) – No. 8 (-)**

**Standard:**

**\*0.4 – 0.6 V (throttle fully closed)**

**\*4.2 – 4.8 V (throttle fully open)**

- A voltage marked \* refers to the value when the input voltage reading (page 5-19) shows 5 V.

If the reading shows other than 5 V, derive a voltage range at the test harness as follows:

Example:

In the case of a input voltage of 4.75 V:

$$0.4 \times 4.75/5.0 = 0.38 \text{ V}$$

$$0.6 \times 4.75/5.0 = 0.57 \text{ V}$$

Thus, the valid range is "0.38 – 0.57 V" for throttle fully closed.

Replace this calculation using 4.2 and 4.8 to get the resulting range for the throttle fully open.

**Is voltage within standard value?**

**NO** – Faulty TP sensor.

**YES** – GO TO STEP 8.

### 8. TP Sensor Connection Inspection

Turn the ignition switch to "OFF."

Remove the test harnesses and connect the ECM connectors.

Place the motorcycle on its side stand.

Turn the ignition switch to "ON."

Check that the MIL blinks.

**Is the MIL blinking?**

**NO** – Temporary failure; the system is normal.

**YES** – Replace the ECM with a new one and inspect again.

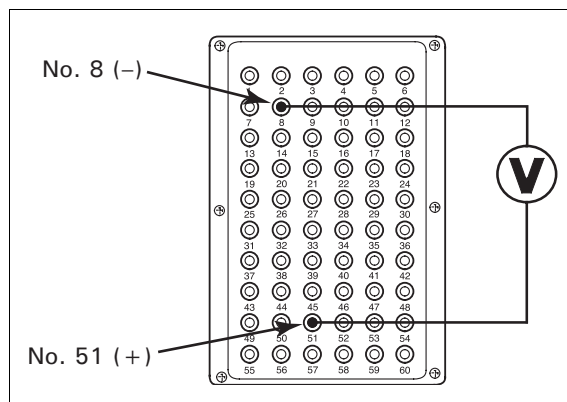

## FUEL SYSTEM (Programmed Fuel Injection)

### MIL 9 BLINKS (IAT SENSOR)

#### 1. IAT Sensor Connection Inspection

Remove the top shelter (page 2-12).  
Turn the ignition switch to "OFF."

Disconnect the IAT sensor 2P connector.  
Check the connector for loose contacts or corroded terminals.

Connect the IAT sensor 2P connector.  
Place the motorcycle on its side stand.  
Turn the ignition switch to "ON."  
Check that the MIL blinks.

##### *Is the MIL blinking?*

**NO** – Temporary failure; the system is normal.

**YES** – GO TO STEP 2.

#### 2. IAT Sensor Power Input Line Voltage Inspection

Turn the ignition switch to "OFF."  
Disconnect the IAT sensor 2P connector.  
Turn the ignition switch to "ON."  
Measure the voltage between the wire harness side 2P connector terminal and ground.

**Connection: Gray/blue (+) – Ground (-)**

**Standard: 4.75 – 5.25 V**

##### *Is the voltage within 4.75 – 5.25 V?*

**NO** – • Open or short circuit in the Gray/blue wire.  
• Loose or poorly connected ECM gray connector.

**YES** – GO TO STEP 3.

#### 3. IAT Sensor Signal Line Voltage Inspection

Measure the voltage between the wire harness side 2P connector terminals.

**Connection: Gray/blue (+) – Green/red (-)**

**Standard: 4.75 – 5.25 V**

##### *Is the voltage within 4.75 – 5.25 V?*

**NO** – • Open circuit in the Green/red wire.  
• Loose or poorly connected ECM black connector.

**YES** – GO TO STEP 4.

#### 4. IAT Sensor Resistance Inspection

Turn the ignition switch to "OFF."  
Measure the resistance between the IAT sensor terminals (at 20 – 30°C/68 – 86°F).

##### *Is resistance within 1 – 4 k?*

**NO** – Faulty IAT sensor.

**YES** – Replace the ECM with a new one and inspect again.

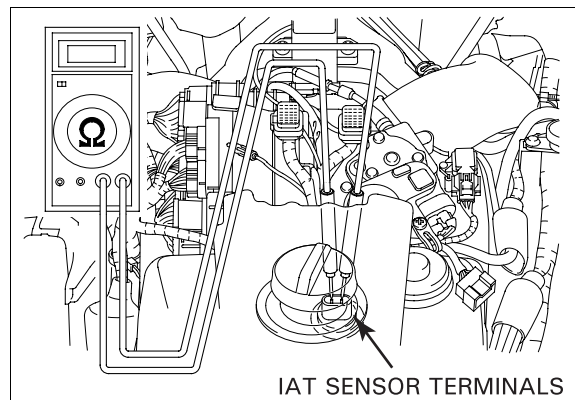
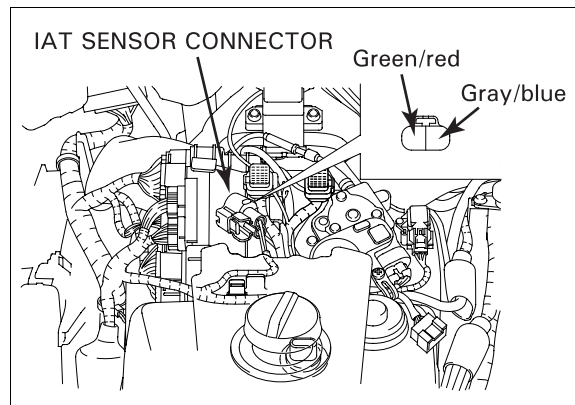

### MIL 10 BLINKS (BARO SENSOR)

#### 1. BARO Sensor Connection Inspection

Remove the top shelter (page 2-12).  
Turn the ignition switch to "OFF."

Disconnect the BARO sensor 3P connector.  
Check the connector for loose contacts or corroded terminals.

Connect the BARO sensor 3P connector.  
Place the motorcycle on its side stand.  
Turn the ignition switch to "ON."  
Check that the MIL blinks.

##### *Is the MIL blinking?*

**NO** – Temporary failure; the system is normal.

**YES** – GO TO STEP 2.

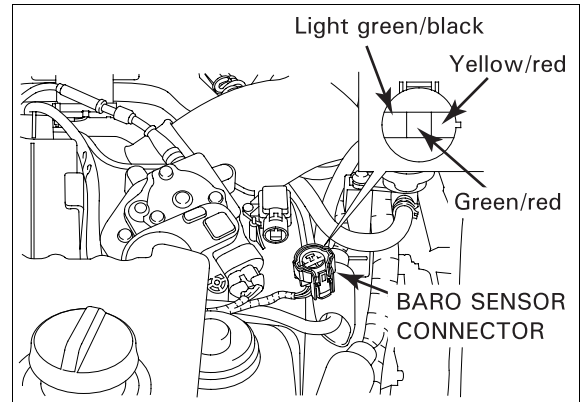

#### 2. BARO Sensor Input Line Voltage Inspection

Turn the ignition switch to "OFF."  
Disconnect the BARO sensor 3P connector.  
Turn the ignition switch to "ON."  
Measure the voltage between the wire harness side 3P connector terminal and ground.

**Connection: Yellow/red (+) – Ground (-)**  
**Standard: 4.75 – 5.25 V**

##### *Is the voltage within 4.75 – 5.25 V?*

**NO** – • Open or short circuit in the Yellow/red wire.  
• Loose or poorly connected ECM black connector.

**YES** – GO TO STEP 3.

#### 3. BARO Sensor Line Voltage Inspection

Measure the voltage between the wire harness side 3P connector terminals.

**Connection: Yellow/red (+) – Green/red (-)**  
**Standard: 4.75 – 5.25 V**

##### *Is the voltage within 4.75 – 5.25 V?*

**NO** – • Open circuit in the Green/red wire.  
• Loose or poorly connected ECM black connector.

**YES** – GO TO STEP 4.

#### 4. BARO Sensor Line Voltage Inspection

Measure the voltage between the wire harness side 3P connector terminals.

**Connection:**  
**Light green/black (+) – Green/red (-)**  
**Standard: 4.75 – 5.25 V**

##### *Is the voltage within 4.75 – 5.25 V?*

**NO** – Open or short circuit in the Light green/black wire.

**YES** – GO TO STEP 5.



## FUEL SYSTEM (Programmed Fuel Injection)

### 5. BARO Sensor Voltage at ECM

Turn the ignition switch to "OFF."  
Connect the BARO sensor 3P connector.  
Connect the test harness set to the ECM connectors (page 5-11).  
Turn the ignition switch to "ON."

Measure the voltage at the test pin box terminals.

**Connection: No. 49 (+) – No. 8 (-)**  
**Standard: 2.7 – 3.1 V (at 760 mm Hg/1,013 hPa)**

***Is the voltage within 2.7 – 3.1 V (at 760 mm Hg/1,013 hPa)?***

- NO** – Faulty BARO sensor.  
**YES** – Replace the ECM with a new one and inspect again.

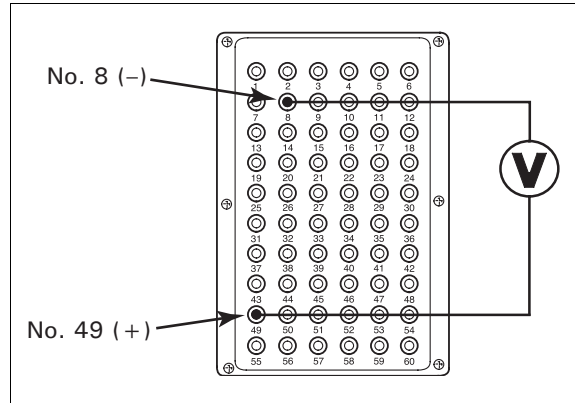

### MIL 11 BLINKS (VEHICLE SPEED SENSOR)

#### 1. Vehicle Speed Sensor Connection Inspection

Remove the top shelter (page 2-12).  
Turn the ignition switch to "OFF."  
Disconnect the vehicle speed sensor 3P connector.  
Check the connector for loose contacts or corroded terminals.

Connect the vehicle speed sensor 3P connector and install the removed parts.  
Run the motorcycle with the engine speed more than 2,100 rpm for 20 seconds or more.  
Let the engine idle and lower the side stand.  
Check that the MIL blinks.

***Is the MIL blinking?***

- NO** – Temporary failure; the system is normal.  
**YES** – GO TO STEP 2.

#### 2. Vehicle Speed Sensor Input Line Voltage Inspection

Turn the ignition switch to "OFF."  
Remove the top shelter (page 2-12) and disconnect the vehicle speed sensor 3P connector.  
Turn the ignition switch to "ON."  
Measure the voltage between the wire harness side 3P connector terminal and ground.

**Connection: Brown/white (+) – Ground (-)**  
**Standard: Battery voltage**

***Does battery voltage exist?***

- NO** – Open or short circuit in the Brown/white wire.  
**YES** – GO TO STEP 3.

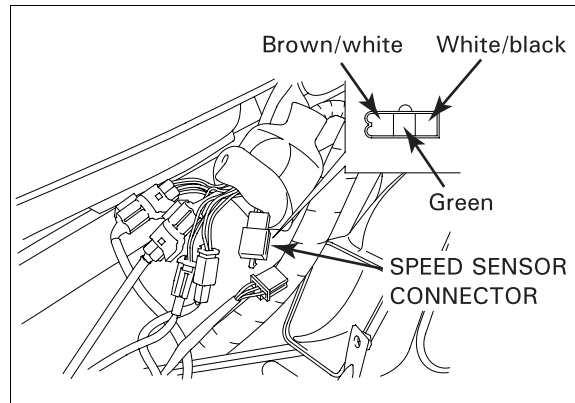

### 3. Vehicle Speed Sensor Line Voltage Inspection

Measure the voltage between the wire harness side 3P connector terminals.

**Connection: Brown/white (+) – Green (-)**

**Standard: Battery voltage**

**Does battery voltage exist?**

**NO** – Open circuit in the Green wire.

**YES** – GO TO STEP 4.

### 4. Vehicle Speed Sensor Line Short Circuit Inspection

Turn the ignition switch to "OFF."  
Disconnect the ECM 22P gray connector.  
Check for continuity between the White/black wire terminal of the wire harness side 3P connector and ground.

**Is there continuity?**

**YES** – Short circuit in the White/black wire.

**NO** – GO TO STEP 5.

### 5. Vehicle Speed Sensor Line Continuity Inspection

Check for continuity between the White/black wire terminals of the vehicle speed sensor 3P connector and ECM 22P connector.

**Is there continuity?**

**NO** – Open circuit in the White/black wire.

**YES** – GO TO STEP 6.

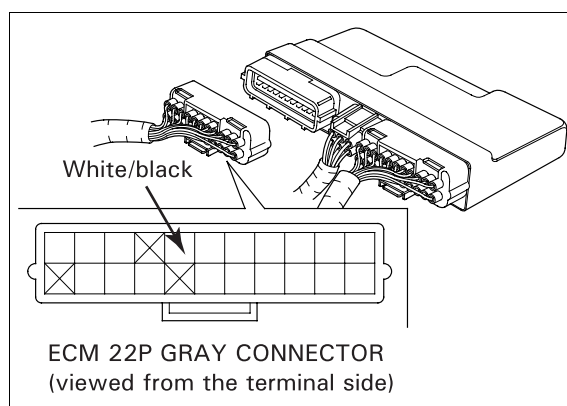

### 6. Vehicle Speed Sensor Pulse Signal Voltage Inspection

Connect the vehicle speed sensor 3P connector.  
Connect the test harness set to the ECM gray connectors (page 5-11).

Shift the transmission into neutral and turn the ignition switch to "ON."  
Measure the voltage at the test pin box terminal and ground while slowly turning the rear wheel by hand.

**Connection: No. 35 (+) – Ground (-)**

**Standard: 0 to 5 V pulse voltage**

**Is the voltage within the standard value?**

**NO** – Faulty vehicle speed sensor.

**YES** – Replace the ECM with a new one and inspect again.

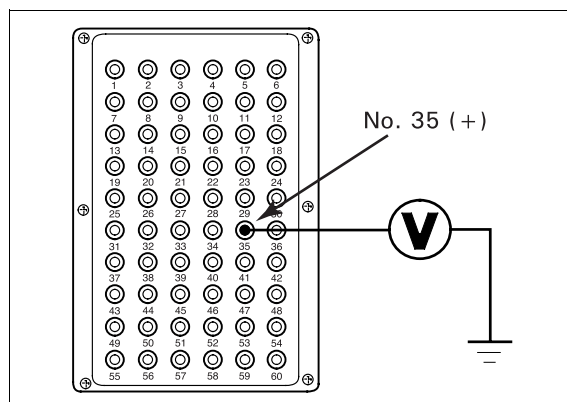

## FUEL SYSTEM (Programmed Fuel Injection)

### MIL 12 BLINKS (No. 1 INJECTOR)

#### 1. Injector Connection Inspection

Remove the right injector cover (page 5-61).  
Turn the ignition switch to "OFF."

Disconnect the No. 1 injector 2P connector.  
Check the connector for loose contacts or corroded terminals.

Connect the No. 1 injector 2P connector.  
Place the motorcycle on its side stand.  
Turn the ignition switch to "ON."  
Check that the MIL blinks.

##### *Is the MIL blinking?*

**NO** – Temporary failure; the system is normal.

**YES** – GO TO STEP 2.

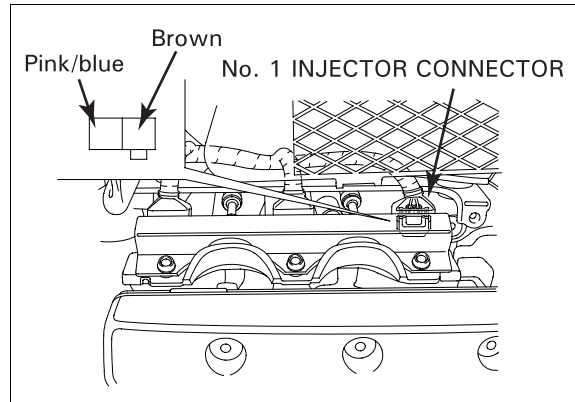

#### 2. No. 1 Injector Resistance Inspection

Turn the ignition switch to "OFF."  
Disconnect the No. 1 injector 2P connector.  
Measure the resistance between the No. 1 injector terminals.

**Standard: 11.1 – 12.3Ω (at 20° C/68° F)**

##### *Is resistance within 11.1 – 12.3Ω (at 20° C/68° F)?*

**NO** – Faulty No. 1 injector.

**YES** – GO TO STEP 3.

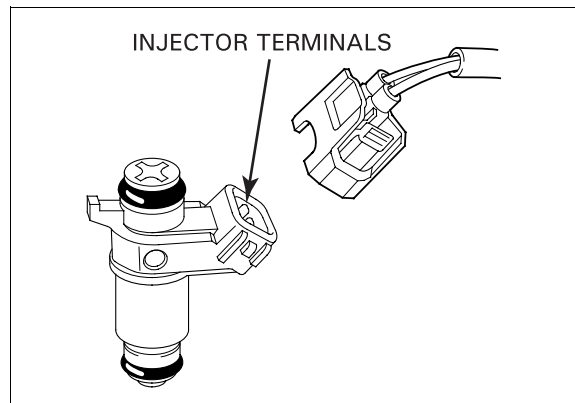

#### 3. No. 1 Injector Short Circuit Inspection

Check for continuity between the No. 1 injector terminal and ground.

##### *Is there continuity?*

**YES** – Faulty No. 1 injector.

**NO** – GO TO STEP 4.

#### 4. No. 1 Injector Power Input Line Inspection

Turn the ignition switch to "ON."  
Measure the voltage between the wire harness side connector terminal of the No. 1 injector and ground.

**Connection: Brown (+) – Ground (-)**

**Standard: Battery voltage**

##### *Does battery voltage exist?*

**NO** – Open circuit in the Brown wire.

**YES** – GO TO STEP 5.

### 5. No. 1 Injector Control Line Short Circuit Inspection

Turn the ignition switch to "OFF."  
 Disconnect the ECM 6P black connector.  
 Check for continuity between the Pink/blue wire terminal of the wire harness side 6P connector and ground.

**Is there continuity?**

- YES** – Short circuit in the Pink/blue wire.
- NO** – GO TO STEP 6.

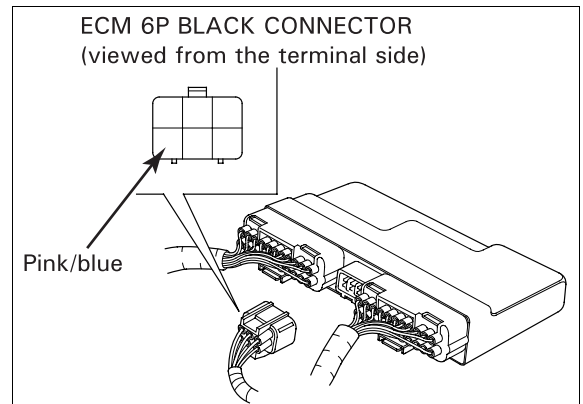

### 6. No. 1 Injector Control Line Continuity Inspection

Check for continuity between the Pink/blue wire terminals of the No. 1 injector 2P connector and ECM 6P black connector.

**Is there continuity?**

- NO** – Open circuit in the Pink/blue wire.
- YES** – Replace the ECM with a new one and inspect again.

## MIL 13 BLINKS (No. 2 INJECTOR)

### 1. Injector Connection Inspection

Remove the left injector cover (page 5-61).  
 Turn the ignition switch to "OFF."

Disconnect the No. 2 injector 2P connector.  
 Check the connector for loose contacts or corroded terminals.

Connect the No. 2 injector 2P connector.  
 Place the motorcycle on its side stand.  
 Turn the ignition switch to "ON."  
 Check that the MIL blinks.

**Is the MIL blinking?**

- NO** – Temporary failure; the system is normal.
- YES** – GO TO STEP 2.

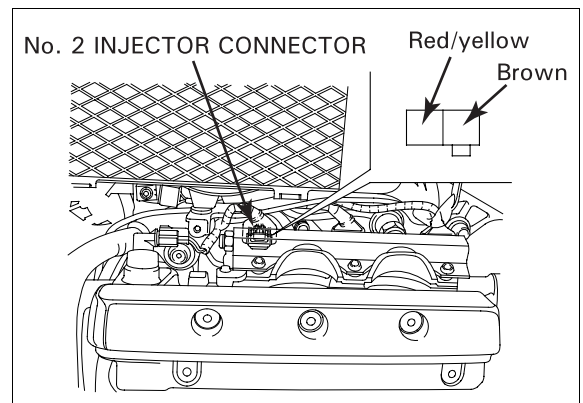

### 2. No. 2 Injector Resistance Inspection

Turn the ignition switch to "OFF."  
 Disconnect the No. 2 injector 2P connector.  
 Measure the resistance between the No. 2 injector terminals.

**Standard: 11.1 – 12.3Ω (at 20° C/68° F)**

**Is resistance within 11.1 – 12.3Ω (at 20° C/68° F)?**

- NO** – Faulty No. 2 injector.
- YES** – GO TO STEP 3.

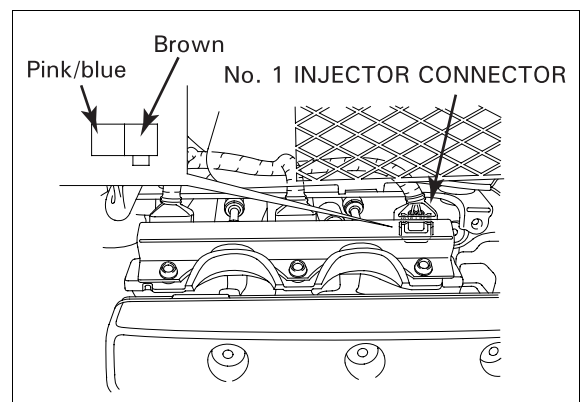

## FUEL SYSTEM (Programmed Fuel Injection)

### 3. No. 2 Injector Short Circuit Inspection

Check for continuity between the No. 2 injector terminal and ground.

**Is there continuity?**

**YES** – Faulty No. 2 injector.

**NO** – GO TO STEP 4.

### 4. No. 2 Injector Power Input Line Inspection

Turn the ignition switch to "ON."

Measure the voltage between the wire harness side connector terminal of the No. 2 injector and ground.

**Connection: Brown (+) – Ground (-)**

**Standard: Battery voltage**

**Does battery voltage exist?**

**NO** – Open circuit in the Brown wire.

**YES** – GO TO STEP 5.

### 5. No. 2 Injector Control Line Short Circuit Inspection

Turn the ignition switch to "OFF."

Disconnect the ECM 6P black connector. Check for continuity between the Red/yellow wire terminal of the wire harness side 6P connector and ground.

**Is there continuity?**

**YES** – Short circuit in the Red/yellow wire.

**NO** – GO TO STEP 6.

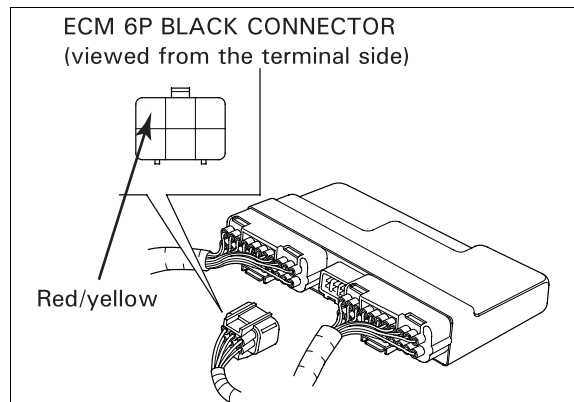

### 6. No. 2 Injector Control Line Continuity Inspection

Check for continuity between Red/yellow wire terminals of the No. 2 injector 2P connector and ECM 6P black connector.

**Is there continuity?**

**NO** – Open circuit in the Red/yellow wire.

**YES** – Replace the ECM with a new one and inspect again.

## MIL 14 BLINKS (No. 3 INJECTOR)

### 1. Injector Connection Inspection

Remove the right injector cover (page 5-61). Turn the ignition switch to "OFF."

Disconnect the No. 3 injector 2P connector. Check the connector for loose contacts or corroded terminals.

Connect the No. 3 injector 2P connector. Place the motorcycle on its side stand. Turn the ignition switch to "ON." Check that the MIL blinks.

**Is the MIL blinking?**

**NO** – Temporary failure; the system is normal.

**YES** – GO TO STEP 2.

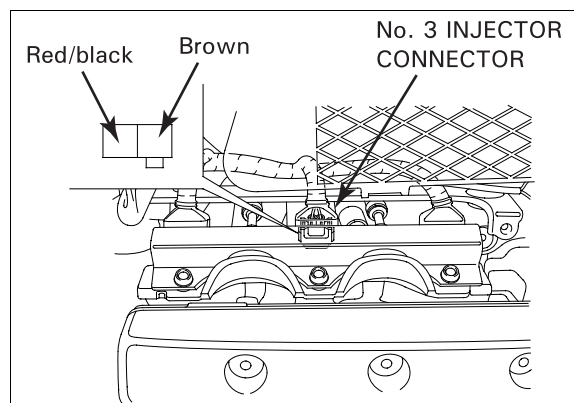

### 2. No. 3 Injector Resistance Inspection

Turn the ignition switch to "OFF."  
Disconnect the No. 3 injector 2P connector.  
Measure the resistance between the No. 3 injector terminals.

**Standard: 11.1 – 12.3Ω (at 20° C/68° F)**

***Is resistance within 11.1 – 12.3Ω (at 20° C/68° F)?***

**NO** – Faulty No. 3 injector.

**YES** – GO TO STEP 3.

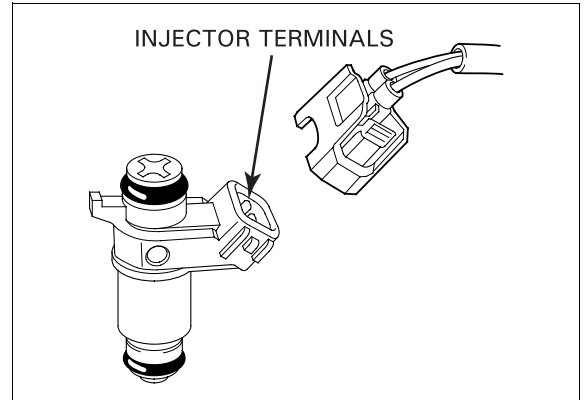

### 3. No. 3 Injector Short Circuit Inspection

Check for continuity between the No. 3 injector terminal and ground.

***Is there continuity?***

**YES** – Faulty No. 3 injector.

**NO** – GO TO STEP 4.

### 4. No. 3 Injector Power Input Line Inspection

Turn the ignition switch to "ON."  
Measure the voltage between the wire harness side connector terminal of the No. 3 injector and ground.

**Connection: Brown (+) – Ground (-)**

**Standard: Battery voltage**

***Does battery voltage exist?***

**NO** – Open circuit in the Brown wire.

**YES** – GO TO STEP 5.

### 5. No. 3 Injector Control Line Short Circuit Inspection

Turn the ignition switch to "OFF."  
Disconnect the ECM 6P black connector.  
Check for continuity between the Red/black wire terminal of the wire harness side 6P connector and ground.

***Is there continuity?***

**YES** – Short circuit in the Red/black wire.

**NO** – GO TO STEP 6.

### 6. No. 3 Injector Control Line Continuity Inspection

Check for continuity between the Red/black wire terminals of the No. 3 injector 2P connector and ECM 6P black connector.

***Is there continuity?***

**NO** – Open circuit in the Red/black wire.

**YES** – Replace the ECM with a new one and inspect again.

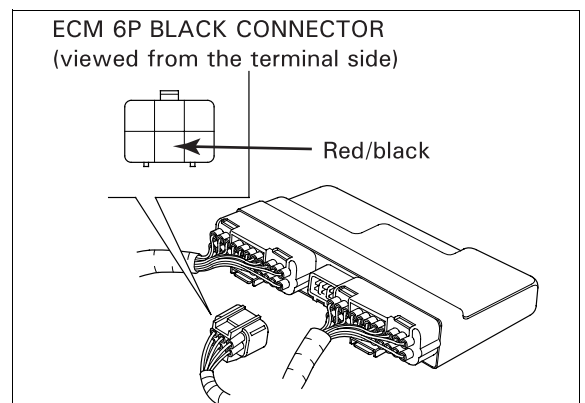

## FUEL SYSTEM (Programmed Fuel Injection)

### MIL 15 BLINKS (No. 4 INJECTOR)

#### 1. Injector Connection Inspection

Remove the left injector cover (page 5-61).  
Turn the ignition switch to "OFF."

Disconnect the No. 4 injector 2P connector.  
Check the connector for loose contacts or corroded terminals.

Connect the No. 4 injector 2P connector.  
Place the motorcycle on its side stand.  
Turn the ignition switch to "ON."  
Check that the MIL blinks.

##### ***Is the MIL blinking?***

**NO** – Temporary failure; the system is normal.

**YES** – GO TO STEP 2.

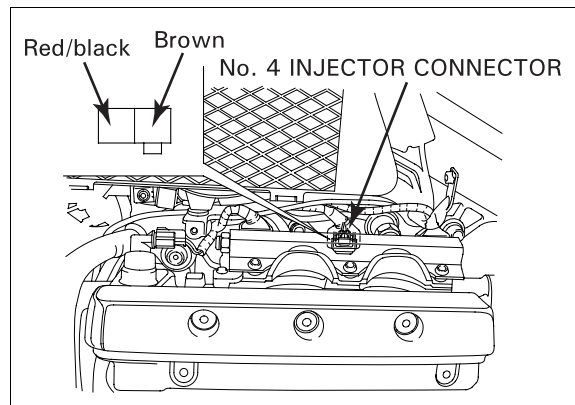

#### 2. No. 4 Injector Resistance Inspection

Turn the ignition switch to "OFF."  
Disconnect the No. 4 injector 2P connector.  
Measure the resistance between the No. 4 injector terminals.

**Standard: 11.1 – 12.3Ω (at 20° C/68° F)**

##### ***Is resistance within 11.1 – 12.3Ω (at 20° C/68° F)?***

**NO** – Faulty No. 4 injector.

**YES** – GO TO STEP 3.

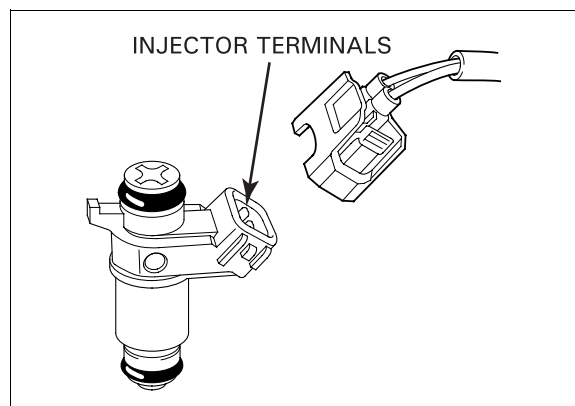

#### 3. No. 4 Injector Short Circuit Inspection

Check for continuity between the No. 4 injector terminal and ground.

##### ***Is there continuity?***

**YES** – Faulty No. 4 injector.

**NO** – GO TO STEP 4.

#### 4. No. 4 Injector Power Input Line Inspection

Turn the ignition switch to "ON."  
Measure the voltage between the wire harness side connector terminal of the No. 4 injector and ground.

**Connection: Brown (+) – Ground (-)**

**Standard: Battery voltage**

##### ***Does battery voltage exist?***

**NO** – Open circuit in the Brown wire.

**YES** – GO TO STEP 5.

## 5. No. 4 Injector Control Line Short Circuit Inspection

Turn the ignition switch to "OFF."  
 Disconnect the ECM 6P black connector.  
 Check for continuity between the Red/black wire terminal of the wire harness side 6P connector and ground.

### Is there continuity?

- YES** – Short circuit in the Red/black wire.  
**NO** – GO TO STEP 6.

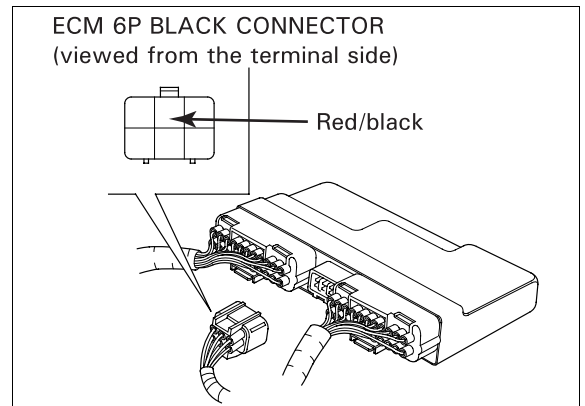

## 6. No. 4 Injector Control Line Continuity Inspection

Check for continuity between the Red/black wire terminals of the No. 4 injector 2P connector and ECM 6P black connector.

### Is there continuity?

- NO** – Open circuit in the Red/black wire.  
**YES** – Replace the ECM with a new one and inspect again.

## MIL 16 BLINKS (No. 5 INJECTOR)

### 1. Injector Connection Inspection

Remove the right injector cover (page 5-61).  
 Turn the ignition switch to "OFF."

Disconnect the No. 5 injector 2P connector.  
 Check the connector for loose contacts or corroded terminals.

Connect the No. 5 injector 2P connector.  
 Place the motorcycle on its side stand.  
 Turn the ignition switch to "ON."  
 Check that the MIL blinks.

### Is the MIL blinking?

- NO** – Temporary failure; the system is normal.  
**YES** – GO TO STEP 2.

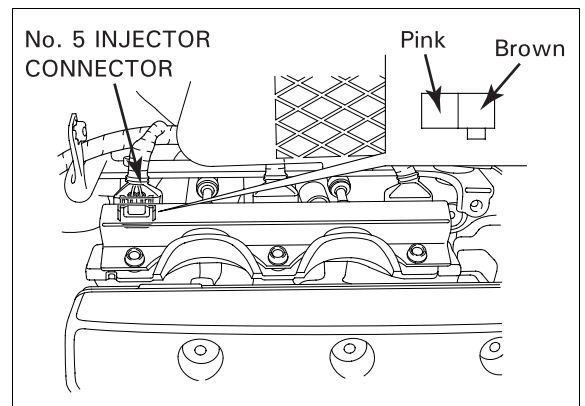

### 2. No. 5 Injector Resistance Inspection

Turn the ignition switch to "OFF."  
 Disconnect the No. 5 injector 2P connector.  
 Measure the resistance between the No. 5 injector terminals.

**Standard: 11.1 – 12.3Ω (at 20° C/68° F)**

### Is resistance within 11.1 – 12.3Ω (at 20° C/68° F)?

- NO** – Faulty No. 5 injector.  
**YES** – GO TO STEP 3.

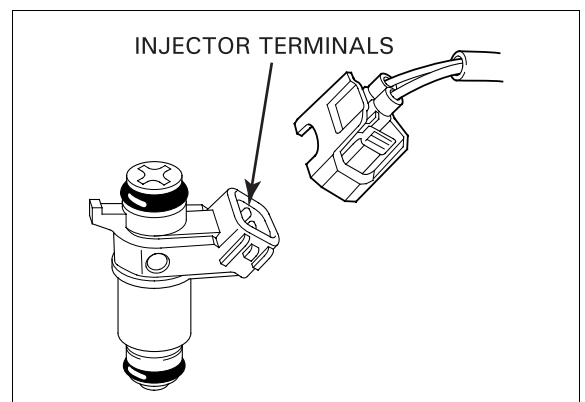



## FUEL SYSTEM (Programmed Fuel Injection)

### 3. No. 5 Injector Short Circuit Inspection

Check for continuity between the No. 5 injector terminal and ground.

**Is there continuity?**

**YES** – Faulty No. 5 injector.

**NO** – GO TO STEP 4.

### 4. No. 5 Injector Power Input Line Inspection

Turn the ignition switch to "ON."

Measure the voltage between the wire harness side connector terminal of the No. 5 injector and ground.

**Connection: Brown (+) – Ground (-)**

**Standard: Battery voltage**

**Does battery voltage exist?**

**NO** – Open circuit in the Brown wire.

**YES** – GO TO STEP 5.

### 5. No. 5 Injector Control Line Short Circuit Inspection

Turn the ignition switch to "OFF."

Disconnect the ECM 6P black connector. Check for continuity between the Pink/white wire terminal of the wire harness side 6P connector and ground.

**Is there continuity?**

**YES** – Short circuit in the Pink or Pink/white wire.

**NO** – GO TO STEP 6.

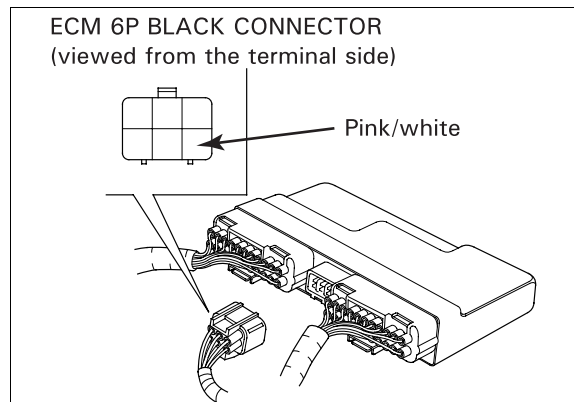

### 6. No. 5 Injector Control Line Continuity Inspection

Check for continuity between the Pink wire terminal of the No. 5 injector 2P connector and the Pink/white wire terminal of the ECM 6P black connector.

**Is there continuity?**

**NO** – Open circuit in the Pink or Pink/white wire.

**YES** – Replace the ECM with a new one and inspect again.

### MIL 17 BLINKS (No. 6 INJECTOR)

#### 1. Injector Connection Inspection

Remove the left injector cover (page 5-61).  
Turn the ignition switch to "OFF."

Disconnect the No. 6 injector 2P connector.  
Check the connector for loose contacts or corroded terminals.

Connect the No. 6 injector 2P connector.  
Place the motorcycle on its side stand.  
Turn the ignition switch to "ON."  
Check that the MIL blinks.

##### *Is the MIL blinking?*

**NO** – Temporary failure; the system is normal.

**YES** – GO TO STEP 2.

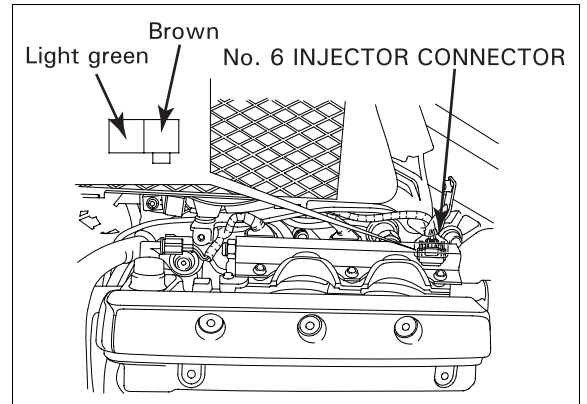

#### 2. No. 6 Injector Resistance Inspection

Turn the ignition switch to "OFF."  
Disconnect the No. 6 injector 2P connector.  
Measure the resistance between the No. 6 injector terminals.

**Standard: 11.1 – 12.3 $\Omega$  (at 20° C/68° F)**

##### *Is resistance within 11.1 – 12.3 $\Omega$ (at 20° C/68° F)?*

**NO** – Faulty No. 6 injector.

**YES** – GO TO STEP 3.

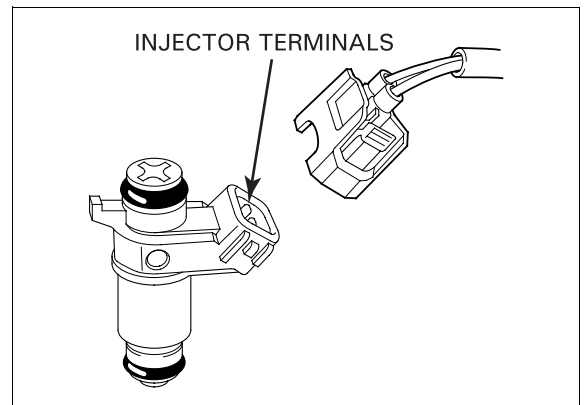

#### 3. No. 6 Injector Short Circuit Inspection

Check for continuity between the No. 6 injector terminal and ground.

##### *Is there continuity?*

**YES** – Faulty No. 6 injector.

**NO** – GO TO STEP 4.

#### 4. No. 6 Injector Power Input Line Inspection

Turn the ignition switch to "ON."  
Measure the voltage between the wire harness side connector terminal of the No. 6 injector and ground.

**Connection: Brown (+) – Ground (–)**

**Standard: Battery voltage**

##### *Does battery voltage exist?*

**NO** – Open circuit in the Brown wire.

**YES** – GO TO STEP 5.

## FUEL SYSTEM (Programmed Fuel Injection)

### 5. No. 6 Injector Control Line Short Circuit Inspection

Turn the ignition switch to "OFF."  
Disconnect the ECM 6P black connector.  
Check for continuity between the Light green wire terminal of the wire harness side 6P connector and ground.

#### *Is there continuity?*

- YES** – Short circuit in the Light green wire.  
**NO** – GO TO STEP 6.

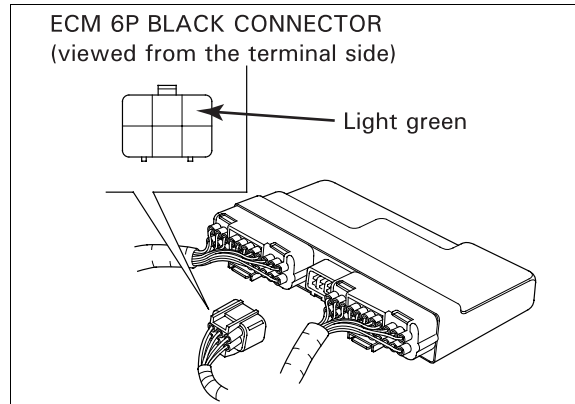

### 6. No. 6 Injector Control Line Continuity Inspection

Check for continuity between the Light green wire terminals of the No. 6 injector 2P connector and ECM 6P black connector.

#### *Is there continuity?*

- NO** – Open circuit in the Light green wire.  
**YES** – Replace the ECM with a new one and inspect again.

## MIL 18 BLINKS (CAMSHAFT POSITION SENSOR)

### 1. Camshaft Position Sensor Peak Voltage Inspection at ECM

Remove the top shelter (page 2-12).  
Turn the ignition switch to "OFF."  
Disconnect the ECM 22P gray connector.  
Check the connector for loose contacts or corroded terminals.

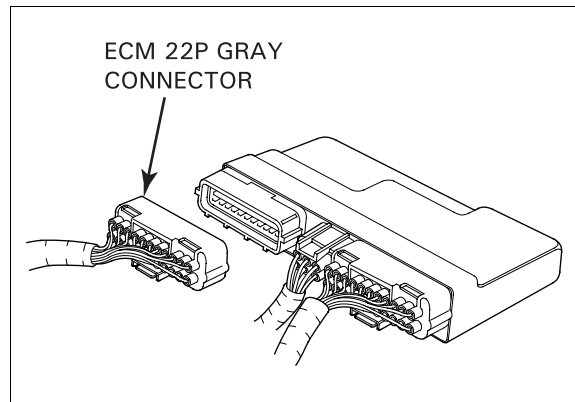

Connect the peak voltage adaptor to the digital multimeter (page 5-10).  
Connect the test harness set to the ECM connectors (page 5-11).  
Turn the ignition switch to "ON."  
Crank the engine with the starter motor and measure the camshaft position sensor peak voltage at the test pin box terminals.

**Connection: No. 52 (+) – No. 21 (-)**  
**Standard: 0.7 V minimum**

#### *Is voltage at least 0.7 V?*

- NO** – GO TO STEP 4.  
**YES** – GO TO STEP 2.

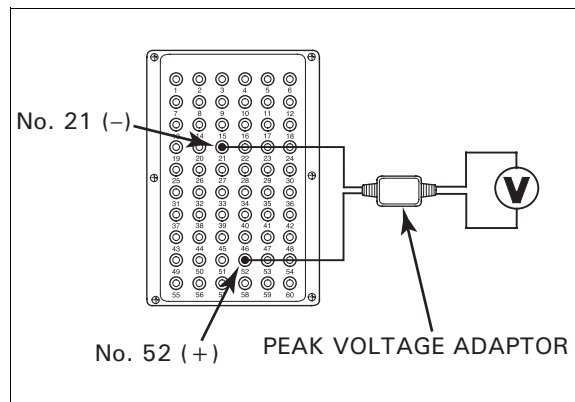

### 2. Camshaft Position Sensor Connection

#### Inspection

Turn the ignition switch to "OFF."

Remove the ECM test harness and connect the ECM connectors.

Reset the self-diagnostic memory (page 5-9).

Check that the engine can be started by cranking it with the starter motor for 10 seconds or more.

#### Does the engine start?

**YES** – Temporary failure; the system is normal.

**NO** – GO TO STEP 3.

### 3. MIL System Inspection

Turn the ignition switch to "OFF."

Short the service check connector terminals with a jumper wire (page 5-8).

Turn the ignition switch to "ON" and check that the MIL blinks.

#### Is the MIL blinking?

**NO** – GO TO STEP 4.

**YES** – Replace the ECM with a new one and inspect again.

### 4. Camshaft Position Sensor Peak Voltage

#### Inspection

Turn the ignition switch to "OFF."

Remove the left injector cover (page 5-61).

Disconnect the camshaft position sensor 2P connector.

Check the connector for loose contacts or corroded terminals.

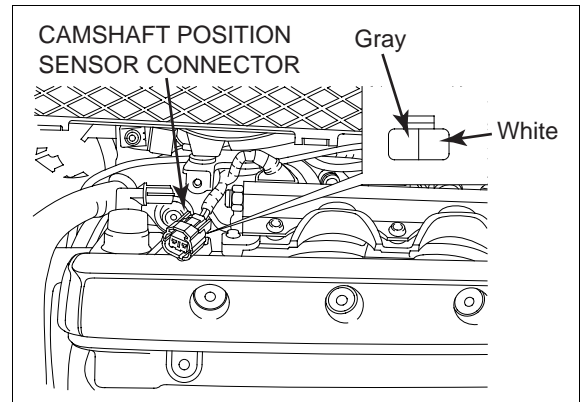

Turn the ignition switch to "ON."

Crank the engine with the starter motor, and measure the camshaft position sensor peak voltage at the camshaft position sensor connector terminals.

**Connection: Gray (+) – White (-)**

**Standard: 0.7 V minimum**

#### Is voltage at least 0.7 V?

**NO** – Faulty camshaft position sensor.

**YES** –

- Open or short circuit in the Gray wire.
- Open circuit in the White or White/yellow wire.

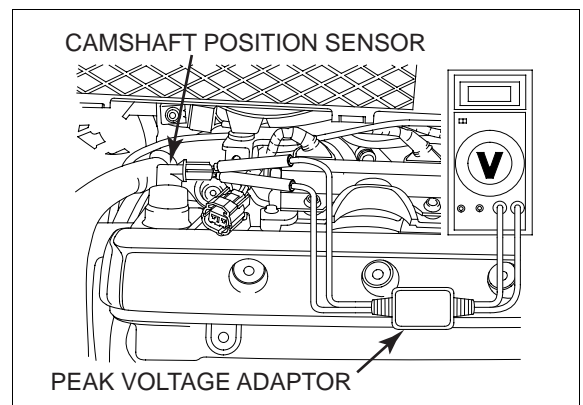

## FUEL SYSTEM (Programmed Fuel Injection)

### MIL 19 BLINKS (IGNITION PULSE GENERATOR)

#### 1. Ignition Pulse Generator Peak Voltage Inspection at ECM

Remove the top shelter (page 2-12).  
Turn the ignition switch to "OFF."

Disconnect the ECM 22P gray connector.  
Check the connector for loose contacts or corroded terminals.

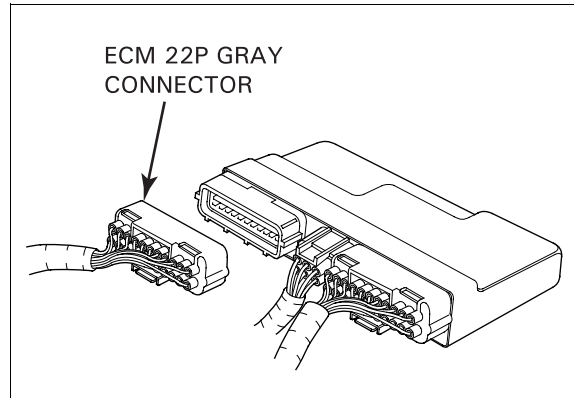

Connect the peak voltage adaptor to the digital multimeter (page 5-10).  
Connect the test harness set to the ECM connectors (page 5-11).  
Turn the ignition switch to "ON."  
Crank the engine with the starter motor and measure the ignition pulse generator peak voltage at the test pin box terminals.

**Connection: No. 41 (+) – No. 21 (-)**

**Standard: 0.7 V minimum**

**Is voltage at least 0.7 V?**

**NO** – GO TO STEP 4.

**YES** – GO TO STEP 2.

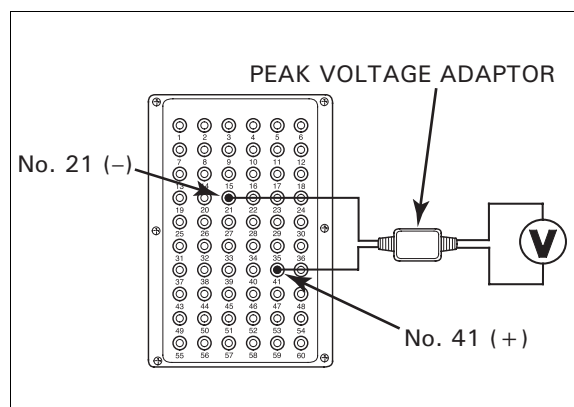

#### 2. Ignition Pulse Generator Connection Inspection

Turn the ignition switch to "OFF."  
Remove the ECM test harness and connect the ECM connectors.  
Reset the self-diagnostic memory (page 5-9).

Check that the engine can be started by cranking it with the starter motor for 10 seconds or more.

**Does the engine start?**

**YES** – Temporary failure; the system is normal.

**NO** – GO TO STEP 3.

#### 3. MIL System Inspection

Turn the ignition switch to "OFF."  
Short the service check connector terminals with a jumper wire (page 5-8).  
Turn the ignition switch to "ON" and check that the MIL blinks.

**Is the MIL blinking?**

**NO** – GO TO STEP 4.

**YES** – Replace the ECM with a new one and inspect again.

### 4. Ignition Pulse Generator Peak Voltage Inspection

Turn the ignition switch to "OFF."  
 Remove the air cleaner housing (page 5-57).  
 Disconnect the ignition pulse generator 2P connector.  
 Check the connector for loose contacts or corroded terminals.

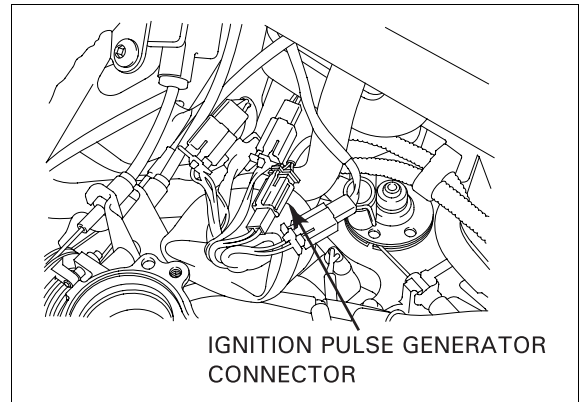

Turn the ignition switch to "ON."  
 Crank the engine with the starter motor, and measure the ignition pulse generator peak voltage at the ignition pulse generator connector terminals.

**Connection: Yellow (+) – White/yellow (-)**  
**Standard: 0.7 V minimum**

**Is voltage at least 0.7 V?**

- NO** – Faulty ignition pulse generator.
- YES** –
- Open or short circuit in the Yellow wire.
  - Open circuit in the White/yellow wire.

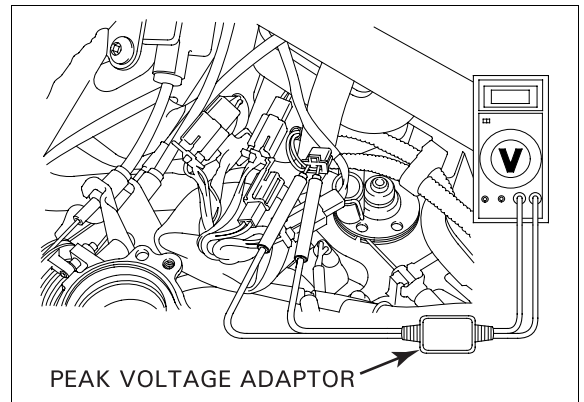

### MIL 21 BLINKS (RIGHT O<sub>2</sub> SENSOR)

#### 1. Right O<sub>2</sub> Sensor Connection Inspection

Remove the top shelter (page 2-12).  
 Turn the ignition switch to "OFF."  
 Disconnect the right O<sub>2</sub> sensor 4P connector.  
 Check the connector for loose contacts or corroded terminals.

Connect the right O<sub>2</sub> sensor 4P connector.  
 Place the motorcycle on its side stand.  
 Start the engine and warm it up until the radiator fan comes on.  
 Snap the engine from idle to 5,000 rpm, then let it idle and check that the MIL blinks.

**Is the MIL blinking?**

- NO** – Temporary failure; the system is normal.
- YES** – GO TO STEP 2.

#### 2. Right O<sub>2</sub> Sensor Signal Line Short Circuit Inspection

Turn the ignition switch to "OFF."  
 Disconnect the right O<sub>2</sub> sensor 4P connector and ECM 22P connectors.  
 Check for continuity between the Black/red wire terminal of the wire harness side 4P connector and ground.

**Is there continuity?**

- YES** – Short circuit in the Black/red wire.
- NO** – GO TO STEP 3.

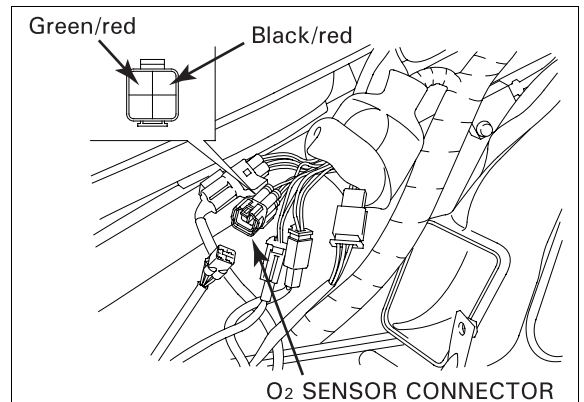

## FUEL SYSTEM (Programmed Fuel Injection)

### 3. Right O<sub>2</sub> Sensor Signal Line Continuity Inspection

Connect the test harness set to the ECM connectors (page 5-10).  
Check for continuity between the wire harness side O<sub>2</sub> sensor 4P connector and test pin box terminals.

**Connection: Black/red – No. 39**

**Is there continuity?**

**NO** – Open circuit in the Black/red wire.

**YES** – GO TO STEP 4.

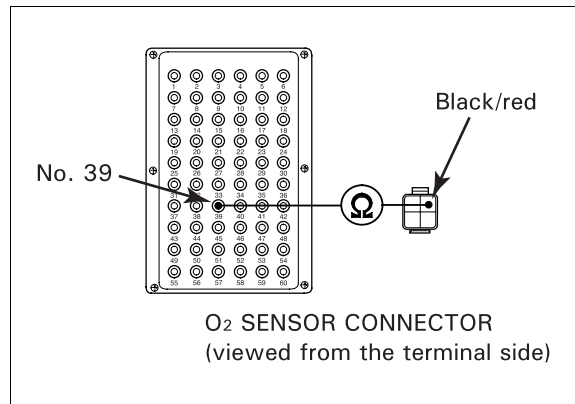

### 4. Right O<sub>2</sub> Sensor Ground Line Continuity Inspection

Check for continuity between the wire harness side O<sub>2</sub> sensor 4P connector and test pin box terminals.

**Connection: Green/red – No.8**

**Is there continuity?**

**NO** – Open circuit in the Green/red wire.

**YES** – GO TO STEP 5.

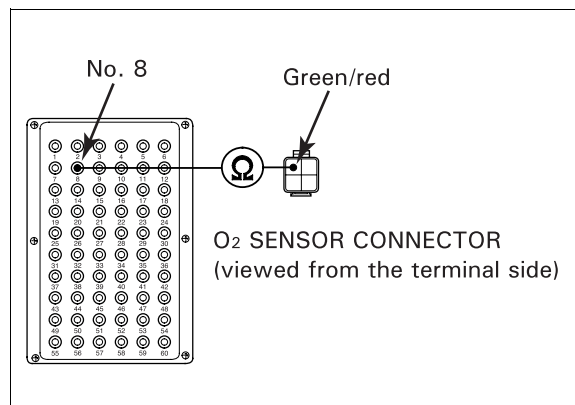

### 5. Right O<sub>2</sub> Sensor Output Voltage Inspection

Connect the right O<sub>2</sub> sensor 4P connector.  
Start the engine, snap it from idle to 5,000 rpm and measure the voltage between the test pin box terminals.

**Connection: No. 39 (+) – No. 8 (-)**

**Standard:**

**0.6 V minimum (with throttle wide open)**

**0.4 V maximum (with throttle quickly closed)**

**Is the voltage within the standard value?**

**NO** – Faulty right O<sub>2</sub> sensor

**YES** – Check the fuel supply system. If the system is normal, replace the ECM with a new one and inspect again.

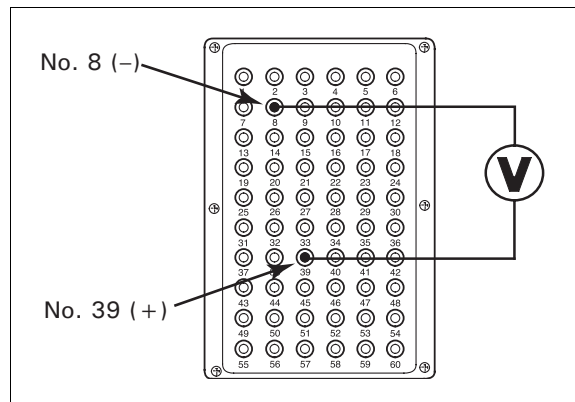

## MIL 22 BLINKS (LEFT O<sub>2</sub> SENSOR)

### 1. Left O<sub>2</sub> Sensor Connection Inspection

Remove the top shelter (page 2-12).  
Turn the ignition switch to "OFF."

Disconnect the left O<sub>2</sub> sensor 4P connector.  
Check the connector for loose contacts or corroded terminals.

Connect the left O<sub>2</sub> sensor 4P connector.  
Place the motorcycle on its side stand.  
Start the engine and warm it up until the radiator fan comes on.

Snap the engine from idle to 5,000 rpm, then let it idle and check that the MIL blinks.

#### *Is the MIL blinking?*

**NO** – Temporary failure; the system is normal.

**YES** – GO TO STEP 2.

### 2. Left O<sub>2</sub> Sensor Signal Line Short Circuit Inspection

Turn the ignition switch to "OFF."  
Disconnect the left O<sub>2</sub> sensor 4P connector and ECM 22P connectors.

Check for continuity between the Black/orange wire terminal of the wire harness side 4P connector and ground.

#### *Is there continuity?*

**YES** – Short circuit in the Black/orange wire.

**NO** – GO TO STEP 3.

### 3. Left O<sub>2</sub> Sensor Signal Line Continuity Inspection

Connect the test harness set to the ECM connectors (page 5-10).

Check for continuity between the wire harness side O<sub>2</sub> sensor 4P connector and test pin box terminals.

**Connection: Black/orange – No. 50**

#### *Is there continuity?*

**NO** – Open circuit in the Black/orange wire.

**YES** – GO TO STEP 4.

### 4. Left O<sub>2</sub> Sensor Ground Line Continuity Inspection

Check for continuity between the wire harness side O<sub>2</sub> sensor 4P connector and test pin box terminals.

**Connection: Green/red – No. 8**

#### *Is there continuity?*

**NO** – Open circuit in the Green/red wire.

**YES** – GO TO STEP 5.

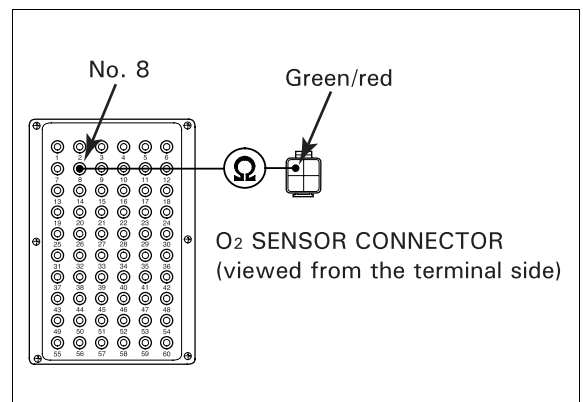
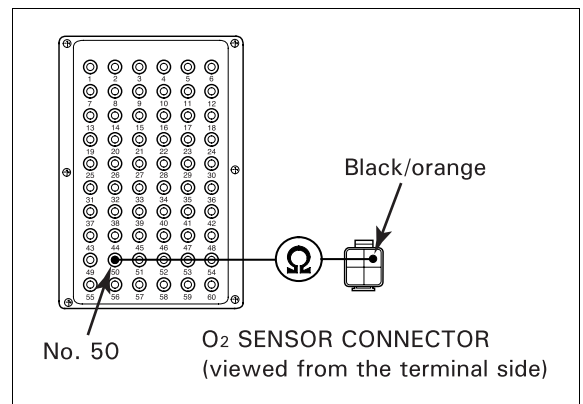
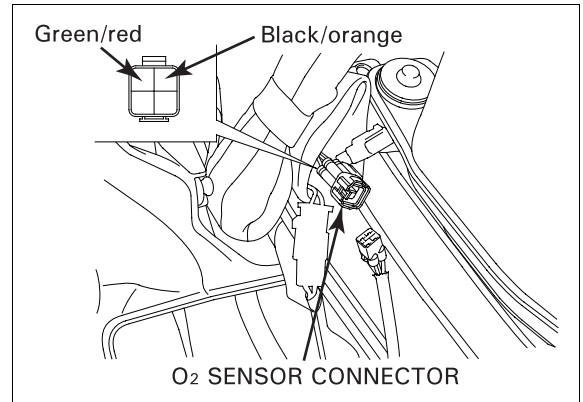



## FUEL SYSTEM (Programmed Fuel Injection)

### 5. Left O<sub>2</sub> Sensor Output Voltage Inspection

Connect the left O<sub>2</sub> sensor 4P connector.  
Start the engine, snap it from idle to 5,000 rpm and measure the voltage between the test pin box terminals.

**Connection: No.50 (+) – No. 8 (-)**

**Standard:**

**0.6 V minimum (with throttle wide open)**

**0.4 V maximum (with throttle quickly closed)**

***Is the voltage within the standard value?***

**NO** – Faulty left O<sub>2</sub> sensor.

**YES** – Check the fuel supply system. If the system is normal, replace the ECM with a new one and inspect again.

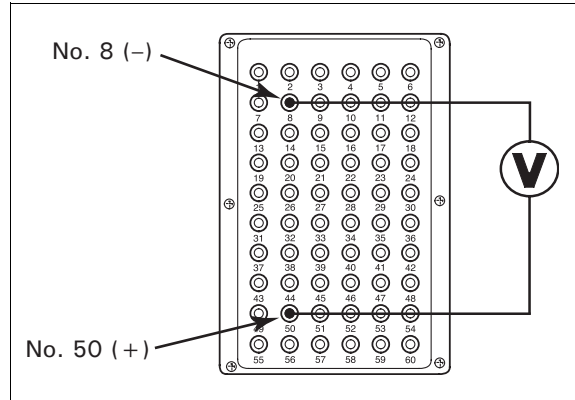

### MIL 23 BLINKS (RIGHT O<sub>2</sub> SENSOR HEATER)

#### 1. Right O<sub>2</sub> Sensor Connection Inspection

Remove the top shelter (page 2-12).  
Turn the ignition switch to "OFF."

Disconnect the right O<sub>2</sub> sensor 4P connector.  
Check the connector for loose contacts or corroded terminals.

Connect the right O<sub>2</sub> sensor 4P connector.  
Place the motorcycle on its side stand.  
Turn the ignition switch to "ON."  
Check that the MIL blinks.

***Is the MIL blinking?***

**NO** – Temporary failure; the system is normal.

**YES** – GO TO STEP 2.

#### 2. Right O<sub>2</sub> Sensor Heater Resistance Inspection

Turn the ignition switch to "OFF."  
Disconnect the right O<sub>2</sub> sensor 4P connector.  
Measure the resistance between the O<sub>2</sub> sensor side connector terminals.

**Connection: White – White**

**Standard: 10 – 40Ω**

***Is the resistance within 10 – 40Ω?***

**NO** – Faulty right O<sub>2</sub> sensor.

**YES** – GO TO STEP 3.

#### 3. Right O<sub>2</sub> Sensor Heater Short Circuit Inspection

Check for continuity between the White wire terminal of the O<sub>2</sub> sensor side connector and ground.

***Is there continuity?***

**YES** – Faulty right O<sub>2</sub> sensor.

**NO** – GO TO STEP 4.

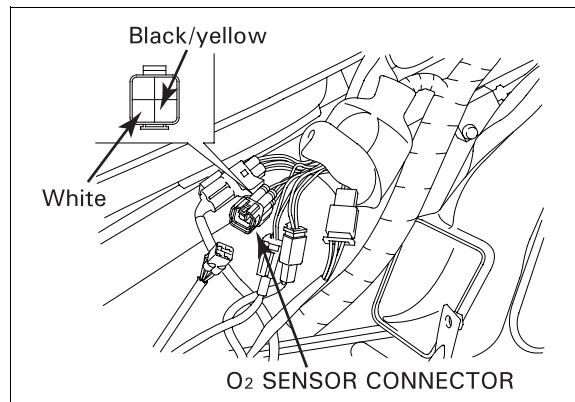

### 4. Right O<sub>2</sub> Sensor Heater Power Input Line Inspection

Turn the ignition switch to "ON."  
Measure the voltage between the wire harness side connector terminal and ground.

**Connection: Black/yellow (+) – Ground (-)**

**Standard: Battery voltage**

**Does battery voltage exist?**

**NO** – Open the circuit in the Black/yellow wire.

**YES** – GO TO STEP 5.

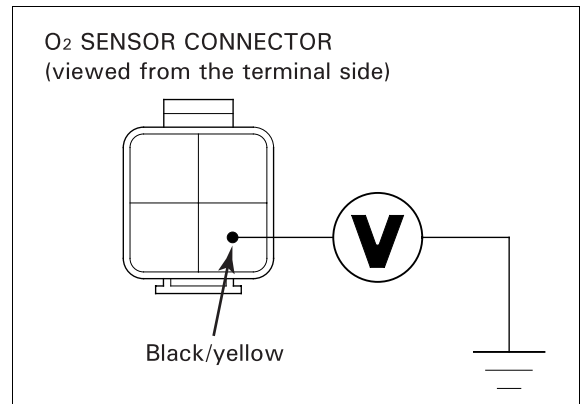

### 5. Right O<sub>2</sub> Sensor Heater Control Line Short Circuit Inspection

Turn the ignition switch to "OFF."  
Disconnect the ECM 22P black connector.  
Turn the ignition switch to "ON."  
Measure the voltage between the wire harness side O<sub>2</sub> sensor 4P connector terminals.

**Connection: Black/yellow (+) – White (-)**

**Standard: No voltage**

**Is voltage present?**

**YES** – Short circuit in the White wire

**NO** – GO TO STEP 6.

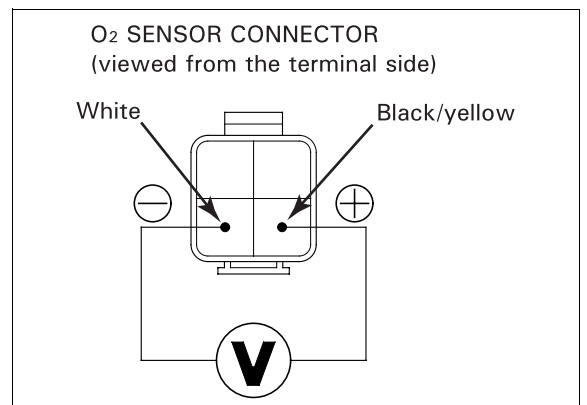

### 6. Right O<sub>2</sub> Sensor Heater Control Line Continuity Inspection

Turn the ignition switch to "OFF."  
Connect the test harness set to the ECM black connectors (page 5-10).  
Check for continuity between the wire harness side O<sub>2</sub> sensor 4P connector and test pin box terminals.

**Connection: White – No. 3**

**Is there continuity?**

**NO** – Open circuit in the White wire.

**YES** – Replace the ECM with a new one and inspect again.

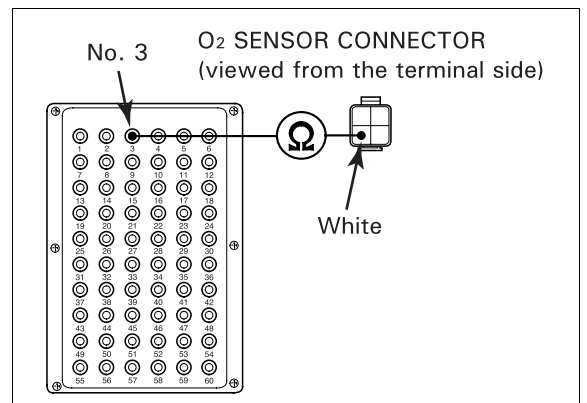

## FUEL SYSTEM (Programmed Fuel Injection)

### MIL 24 BLINKS (LEFT O<sub>2</sub> SENSOR HEATER)

#### 1. Left O<sub>2</sub> Sensor Connection Inspection

Remove the top shelter (page 2-12).  
Turn the ignition switch to "OFF."

Disconnect the left O<sub>2</sub> sensor 4P connector.  
Check the connector for loose contacts or corroded terminals.

Connect the left O<sub>2</sub> sensor 4P connector.  
Place the motorcycle on its side stand.  
Turn the ignition switch to "ON."  
Check that the MIL blinks.

##### *Is the MIL blinking?*

**NO** – Temporary failure; the system is normal.

**YES** – GO TO STEP 2.

#### 2. Left O<sub>2</sub> Sensor Heater Resistance Inspection

Turn the ignition switch to "OFF."  
Disconnect the left O<sub>2</sub> sensor 4P connector.  
Measure the resistance between the O<sub>2</sub> sensor side connector terminals.

**Connection: White – White**

**Standard: 10 – 40Ω**

##### *Is the resistance within 10 – 40Ω?*

**NO** – Faulty left O<sub>2</sub> sensor.

**YES** – GO TO STEP 3.

#### 3. Left O<sub>2</sub> Sensor Heater Short Circuit Inspection

Check for continuity between the White wire terminal of the O<sub>2</sub> sensor side connector and ground.

##### *Is there continuity?*

**YES** – Faulty left O<sub>2</sub> sensor.

**NO** – GO TO STEP 4.

#### 4. Left O<sub>2</sub> Sensor Heater Power Input Line Inspection

Turn the ignition switch to "ON."  
Measure the voltage between the wire harness side connector terminal and ground.

**Connection: Black/yellow (+) – Ground (-)**

**Standard: Battery voltage**

##### *Does battery voltage exist?*

**NO** – Open circuit in the Black/yellow wire.

**YES** – GO TO STEP 5.

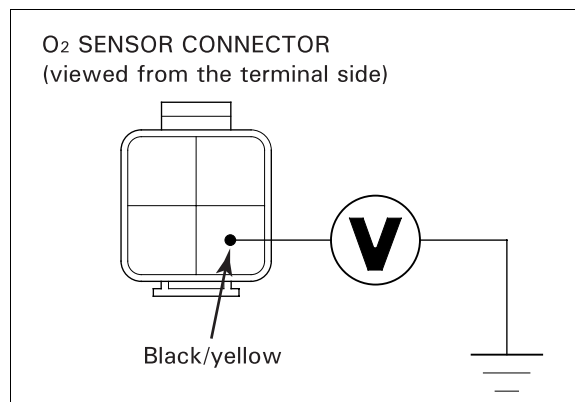
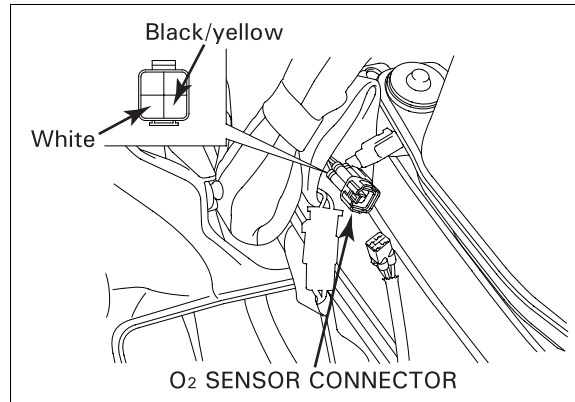

### 5. Left O<sub>2</sub> Sensor Heater Control Line Short Circuit Inspection

Turn the ignition switch to "OFF."  
 Disconnect the ECM 22P black connector.  
 Turn the ignition switch to "ON."  
 Measure the voltage between the wire harness side O<sub>2</sub> sensor 4P connector terminals.

**Connection: Black/yellow (+) – White (–)**

**Standard: No voltage**

**Is voltage present?**

**YES** – Short circuit in the White wire.

**NO** – GO TO STEP 6.

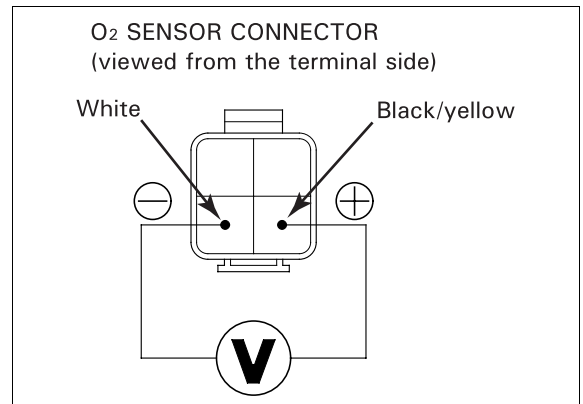

### 6. Left O<sub>2</sub> Sensor Heater Control Line Continuity Inspection

Turn the ignition switch to "OFF."  
 Connect the test harness set to the ECM black connectors (page 5-10).  
 Check for continuity between the wire harness side O<sub>2</sub> sensor 4P connector and test pin box terminals.

**Connection: White – No. 14**

**Is there continuity?**

**NO** – Open circuit in White wire.

**YES** – Replace the ECM with a new one and inspect again.

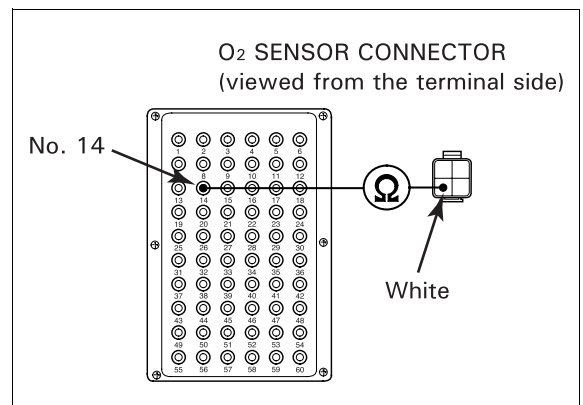

## MIL 25 BLINKS (RIGHT KNOCK SENSOR)

### 1. Right Knock Sensor Connection Inspection

Remove the right front exhaust pipe protector (page 2-18).

Turn the ignition switch to "OFF."

Disconnect the right knock sensor 1P connector.  
 Check the connector for loose contacts or corroded terminal.

Connect the right knock sensor 1P connector.  
 Place the motorcycle on its side stand.  
 Start the engine and hold the engine speed above 2,500 rpm for 10 seconds or more.  
 Check that the MIL blinks.

**Is the MIL blinking?**

**NO** – Temporary failure; the system is normal.

**YES** – GO TO STEP 2.

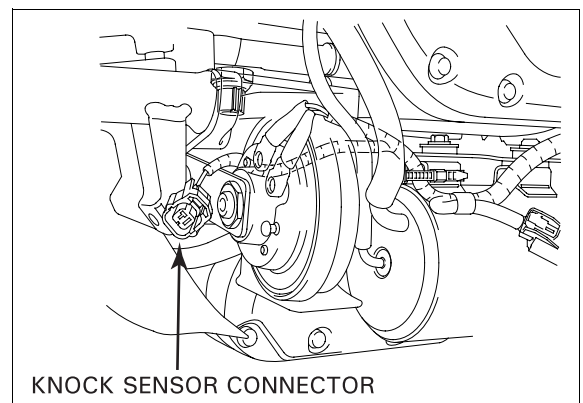

## FUEL SYSTEM (Programmed Fuel Injection)

### 2. Right Knock Sensor Line Short Circuit Inspection

Turn the ignition switch to "OFF."  
Disconnect the right knock sensor 1P connector and ECM 22P gray connector.  
Check for continuity between the wire harness side knock sensor 1P connector terminal and ground.

#### *Is there continuity?*

**YES** – Short circuit in the Red/blue wire.

**NO** – GO TO STEP 3.

### 3. Right Knock Sensor Line Continuity Inspection

Check for continuity between the Red/blue wire terminals of the wire harness side knock sensor connector and ECM 22P gray connector.

#### *Is there continuity?*

**NO** – Open circuit in Red/blue wire.

**YES** – GO TO STEP 4.

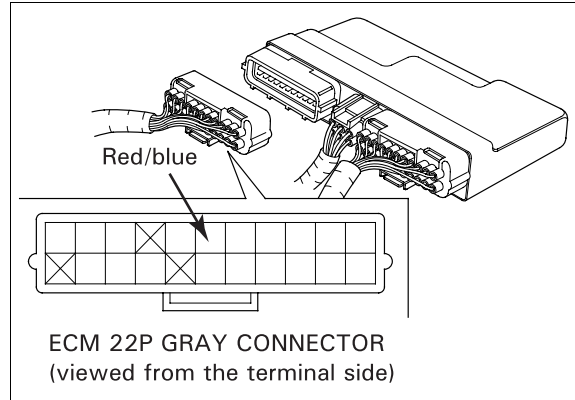

### 4. Right Knock Sensor Operation Inspection

Replace the knock sensor with a new one (page 5-69).  
Place the motorcycle on its side stand.  
Start the engine and hold the engine speed above 2,500 rpm for 10 seconds or more.  
Check that the MIL blinks.

#### *Is the MIL blinking?*

**NO** – Original knock sensor is faulty.

**YES** – Replace the ECM with a new one and inspect again.

## MIL 26 BLINKS (LEFT KNOCK SENSOR)

### 1. Left Knock Sensor Connection Inspection

Remove the left front exhaust pipe protector (page 2-18).  
Turn the ignition switch to "OFF."

Disconnect the left knock sensor 1P connector.  
Check the connector for loose contacts or corroded terminal.

Connect the left knock sensor 1P connector.  
Place the motorcycle on its side stand.  
Start the engine and hold the engine speed above 2,500 rpm for 10 seconds or more.  
Check that the MIL blinks.

#### *Is the MIL blinking?*

**NO** – Temporary failure; the system is normal.

**YES** – GO TO STEP 2.

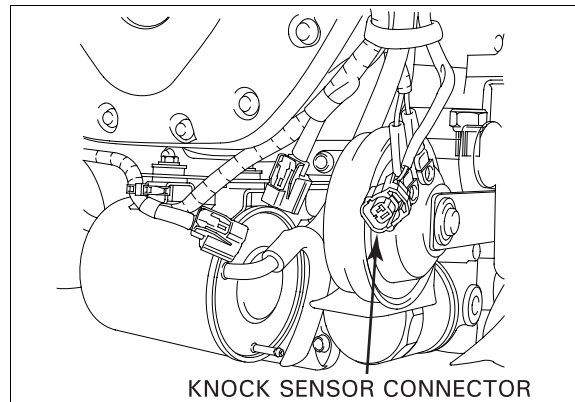

### 2. Left Knock Sensor Line Short Circuit Inspection

Turn the ignition switch to "OFF."  
 Disconnect the left knock sensor 1P connector and ECM 22P gray connector.  
 Check for continuity between the wire harness side knock sensor 1P connector terminal and ground.

**Is there continuity?**

**YES** – Short circuit in the Blue wire.

**NO** – GO TO STEP 3.

### 3. Left Knock Sensor Line Continuity Inspection

Check for continuity between the Blue wire terminals of the wire harness side knock sensor connector and ECM 22P gray connector.

**Is there continuity?**

**NO** – Open circuit in the Blue wire.

**YES** – GO TO STEP 4.

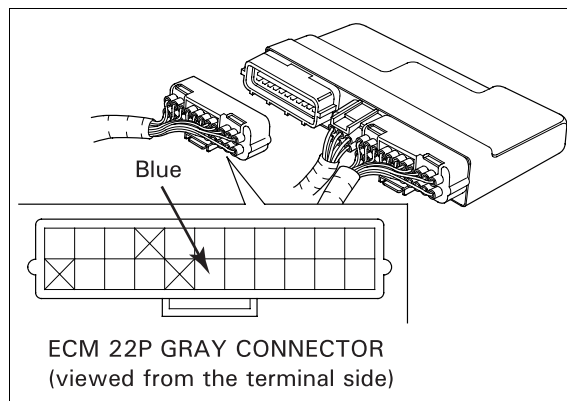

### 4. Left Knock Sensor Operation Inspection

Replace the knock sensor with a new one (page 5-69).

Place the motorcycle on its side stand.

Start the engine and hold the engine speed above 2,500 rpm for 10 seconds or more.

Check that the MIL blinks.

**Is the MIL blinking?**

**NO** – Original knock sensor is faulty.

**YES** – Replace the ECM with a new one and inspect again.

## MIL 29 BLINKS (IAC VALVE)

### 1. IAC Valve Power Input Line Voltage Inspection

Remove the top shelter (page 2-12).

Turn the ignition switch to "OFF."

Disconnect the engine sub-wire harness 8P connector.

Check the connector for loose contacts or corroded terminals.

Turn the ignition switch to "ON."

Measure the voltage between the main wire harness side 8P connector terminal and ground.

**Connection: Black/yellow (+) – Ground (-)**

**Standard: Battery voltage**

**Does battery voltage exist?**

**NO** – Open or short circuit in the Black/yellow wire of the main wire harness.

**YES** – GO TO STEP 2.

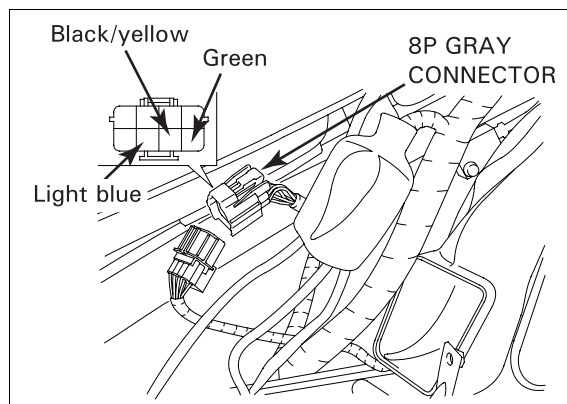

## FUEL SYSTEM (Programmed Fuel Injection)

### 2. IAC Valve Ground Line Short Circuit Inspection

Turn the ignition switch to "OFF."  
Check for continuity between the Green wire terminal of the main wire harness side 8P connector and ground.

**Is there continuity?**

**NO** – Open circuit in the Green wire of the main wire harness.

**YES** – GO TO STEP 3.

### 3. IAC Valve Signal Line Short Circuit Inspection

Disconnect the ECM 22P black connector.  
Check for continuity between the Light blue wire terminal of the main wire harness side 8P connector and ground.

**Is there continuity?**

**YES** – Short circuit in the Light blue wire of the main wire harness.

**NO** – GO TO STEP 4.

### 4. IAC Valve Signal Line Continuity Inspection

Check for continuity between the Light blue wire terminals of the main wire harness side 8P connector and ECM 22P black connector.

**Is there continuity?**

**NO** – Open circuit in the Light blue wire of the main wire harness.

**YES** – GO TO STEP 5.

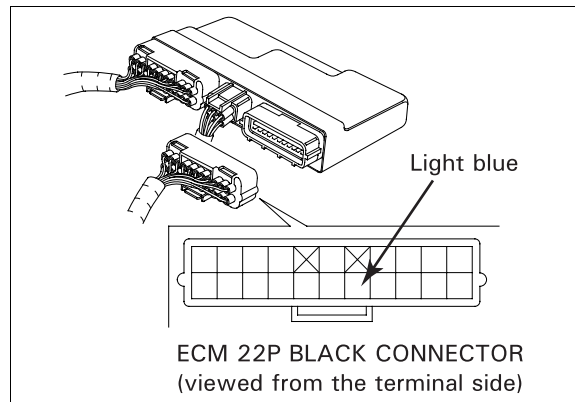

### 5. IAC Valve Harness Continuity Inspection

Remove the fuel tank (page 5-56).  
Disconnect the IAC valve 3P connector.  
Check the connector for loose contacts or corroded terminals.

Check for continuity of the following wires between the 8P connector and IAC valve connector.

- Black/yellow
- Green
- Light blue

**Is there continuity?**

**NO** – Open circuit in the following wires of the engine sub-wire harness:

- Black/yellow
- Green
- Light blue

**YES** – GO TO STEP 6.

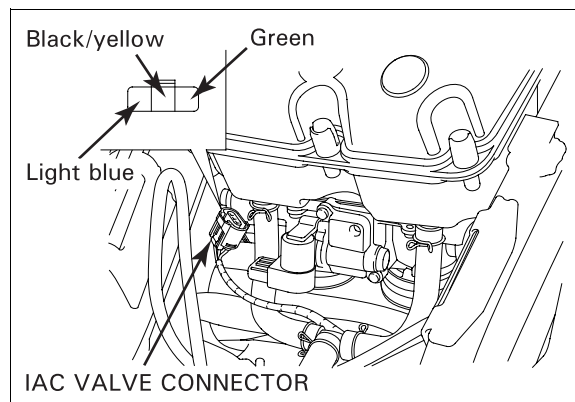

### 6. IAC Valve Harness Short Circuit Inspection

Check continuity between the following wire terminal and ground at the wire harness side IAC valve 3P connector.

- Black/yellow
- Green
- Light blue

#### *Is there continuity?*

**YES** – Short circuit in the following wires of the engine sub-wire harness:

- Black/yellow
- Green
- Light blue

**NO** – GO TO STEP 7.

### 7. IAC Valve Signal Voltage at ECM Inspection

Connect the IAC valve 3P connector and the engine sub-wire harness 8P connector.  
Install the fuel tank (page 5-56).  
Turn the ignition switch to “ON.”

Measure the voltage between the ECM 22P black connector terminal and ground.

**Connection: Light blue (+) – Ground (-)**

**Standard: Battery voltage**

#### *Does battery voltage exist?*

**NO** – Faulty IAC valve.

**YES** – GO TO STEP 8.

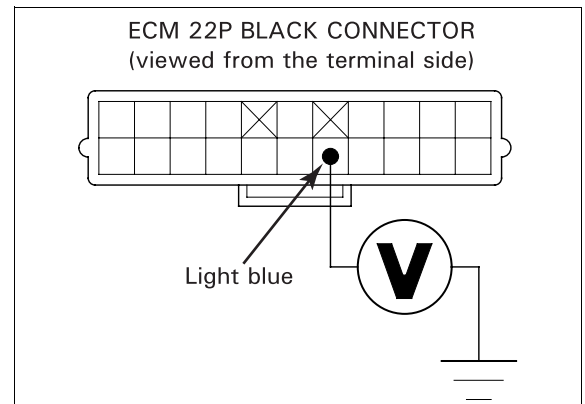

### 8. IAC Valve Connection Inspection

Turn the ignition switch to “OFF.”  
Connect the ECM 22P black connector.

Place the motorcycle on its side stand.  
Start the engine, let it idle and check that the MIL blinks.

#### *Is the MIL blinking?*

**NO** – Temporary failure; the system is normal.

**YES** – Replace the ECM with a new one and inspect again.



## FUEL SYSTEM (Programmed Fuel Injection)

### MIL 33 BLINKS (E<sup>2</sup>-PROM)

#### 1. ECM Connectors Connection Inspection

Remove the top shelter (page 2-12).  
Turn the ignition switch to "OFF."

Disconnect the ECM connectors.  
Check the connector for loose contacts or corroded terminals.

Connect the ECM connectors.  
Short the service check connector terminals with a jumper wire (page 5-8).  
Turn the ignition switch to "ON" and check that the MIL blinks.

***Is the MIL blinking 33 times?***

**YES** – GO TO STEP 2.

**NO** – GO TO STEP 3.

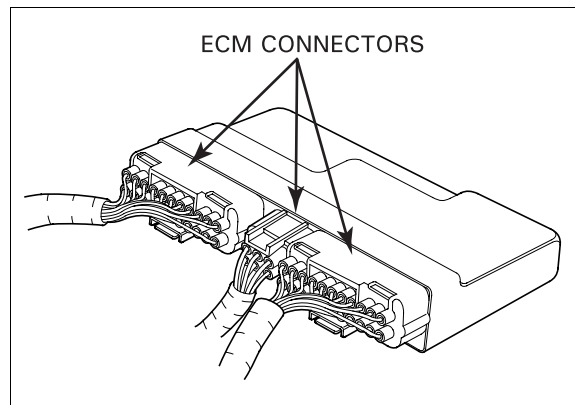

#### 2. Recheck MIL Blinks

Reset the self-diagnostic memory (page 5-9).  
Turn the ignition switch to "ON" and check that the MIL blinks.

***Is the MIL blinking 33 times?***

**YES** – Faulty ECM.

**NO** – GO TO STEP 3.

#### 3. Recheck MIL Blinks

Turn the ignition switch to "OFF."  
Remove the jumper wire from the service check connector.

Place the motorcycle on its side stand.  
Turn the ignition switch to "ON" and check that the MIL blinks.

***Is the MIL blinking?***

**NO** – No problem or check other failure.

**YES** – GO TO STEP 4.

#### 4. Recheck MIL Blinks

Turn the ignition switch to "OFF."  
Short the service check connector terminals with a jumper wire (page 5-8).  
Turn the ignition switch to "ON" and check that the MIL blinks.

***Is the MIL blinking?***

**NO** – No problem or check other failure.

**YES** – GO TO STEP 5.

#### 5. Recheck MIL Blinks

Reset the self-diagnostic memory (page 5-9).  
Turn the ignition switch to "ON" and check that the MIL blinks.

***Is the MIL blinking?***

**NO** – No problem or check other failure.

**YES** – Replace the ECM with a new one.

### MIL 41 BLINKS (GEAR POSITION SWITCH)

#### 1. Neutral and Overdrive Indicator Inspection

Check that the neutral indicator and overdrive indicator function properly.

***Are the neutral indicator and overdrive indicator functioning properly?***

**NO** – Inspect the neutral indicator system (page 20-26).

**YES** – GO TO STEP 2.

#### 2. Reverse and Cruise Control System Operation Inspection

Make sure the reverse system and cruise control system function properly.

***Is the reverse system and cruise control system functioning properly?***

**NO** – • Inspect the reverse system (section 18).  
• Inspect the cruise control system (section 20).

**YES** – GO TO STEP 3.

#### 3. Gear Position Switch – 2nd Gear Line Continuity Inspection

Place the motorcycle on its center stand.

Remove the top shelter (page 2-12).

Turn the ignition switch to “OFF.”

Disconnect the ECM 22P gray connector.

Shift the transmission into 2nd gear.

Check for continuity between the Black/yellow wire terminal of the wire harness side connector and ground.

***Is there continuity?***

**NO** – • Faulty gear position switch.  
• Open circuit in the Black/yellow wire of the main wire harness.

**YES** – GO TO STEP 4.

#### 4. Gear Position Switch – 3rd Gear Line Short Circuit Inspection

Check for continuity between the White/red wire terminal of the wire harness side connector and ground.

***Is there continuity?***

**YES** – • Faulty gear position switch.  
• Short circuit in the White/red wire of the main wire harness.

**NO** – GO TO STEP 5.

## FUEL SYSTEM (Programmed Fuel Injection)

---

### 5. Gear Position Switch – 3rd Gear Line Continuity Inspection

Shift the transmission into 3rd gear.  
Check for continuity between the White/red wire terminal of the wire harness side connector and ground.

#### *Is there continuity?*

**NO** – • Faulty gear position switch.  
• Open circuit in the White/red wire of the main wire harness.

**YES** – GO TO STEP 6.

### 6. Gear Position Switch – 2nd Gear Line Short Circuit Inspection

Check for continuity between the Black/yellow wire terminal of the wire harness side connector and ground.

#### *Is there continuity?*

**YES** – • Faulty gear position switch.  
• Short circuit in the Black/yellow wire of the main wire harness.

**NO** – GO TO STEP 7.

### 7. 1st Gear Selected, Clutch Engaged, Side Stand Retracted Line Continuity Inspection

Shift the transmission into 1st gear and retract the side stand.

Check for continuity between the Blue/red wire terminal (-) of the wire harness side connector and ground (+) with the clutch lever squeezed.

#### NOTE:

- When there is continuity, a small resistance value will register.
- If there is no continuity, recheck with reverse connections.

#### *Is there continuity?*

**NO** – • Open circuit in the Blue/red wire of the main wire harness between the ECM and reverse regulator assembly.  
• Faulty diode in the reverse regulator assembly.  
• Open circuit in the Green/red wire of the main wire harness between the reverse regulator assembly and side stand switch.  
• Faulty clutch switch.  
• Faulty side stand switch.

**YES** – GO TO STEP 8.

### 8. 1st Gear Selected, Side Stand Retracted Line Short Circuit Inspection

Check for continuity between the Blue/red wire terminal (-) of the wire harness side connector and ground (+) with the clutch lever released. Recheck with reverse connections.

#### *Is there continuity?*

- YES** - • Short circuit in the Blue/red wire of the main wire harness between the ECM and reverse regulator assembly.  
• Short circuit in the Green/red wire of the main wire harness between the reverse regulator assembly and clutch switch.  
• Faulty clutch switch.

**NO** - GO TO STEP 9.

### 9. Side Stand Switch Line Short Circuit Inspection

Extend the side stand. Check for continuity between the Blue/red wire terminal (-) of the wire harness side connector and ground (+) with the clutch lever squeezed. Recheck with reverse connections.

#### *Is there continuity?*

- YES** - • Short circuit in the Green/red wire of the main wire harness between the clutch switch and side stand switch.  
• Faulty side stand switch.

**NO** - Replace the ECM with a new one and inspect again.

## FUEL SYSTEM (Programmed Fuel Injection)

### FUEL LINE INSPECTION

#### FUEL PRESSURE INSPECTION

Remove the front fairing (page 2-10).

Remove the two bolts and left injector cover.

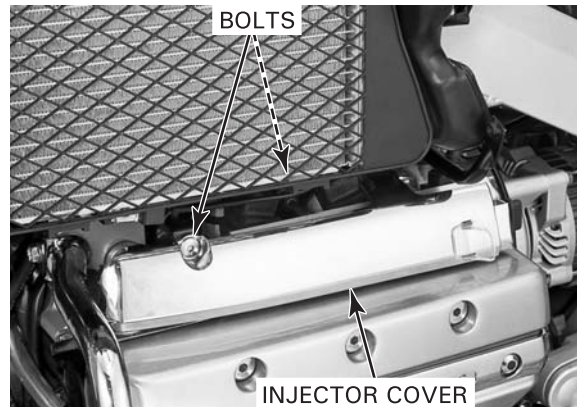

Pinch the pressure regulator vacuum hose using a hose clamp.

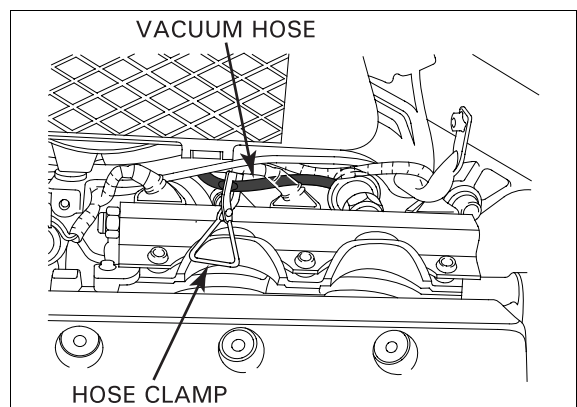

Cover the sealing bolt with a rag or shop towel.

*Do not loosen or remove the banjo bolt. If it is loosened or removed, replace the sealing washer with a new one and tighten it to the specified torque.*

Remove the sealing bolt and sealing washer.

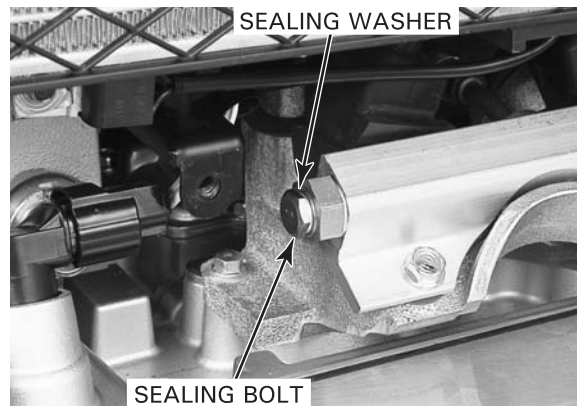

Connect the fuel pressure gauge to the banjo bolt.

#### TOOL:

**Fuel pressure gauge**

**07406-0040002 or  
07406-004000B or  
07406-004000A  
(U.S.A. only)**

Start the engine, let it idle and read the fuel pressure.

**FUEL PRESSURE: 343 kPa (3.5 kgf/cm<sup>2</sup>, 50 psi)**

If the pressure is higher than the specified pressure, inspect the following:

- clogged fuel return hose
- pressure regulator
- fuel pump (page 5-54)



## FUEL SYSTEM (Programmed Fuel Injection)

If the pressure is lower than specified pressure, inspect the following:

- clogged fuel filter
- pressure regulator
- fuel pump (page 5-54)

After inspection, remove the fuel pressure gauge.

Install the sealing bolt with a new sealing washer and tighten it.

**TORQUE: 12 N-m (1.2 kgf-m, 9 lbf-ft)**

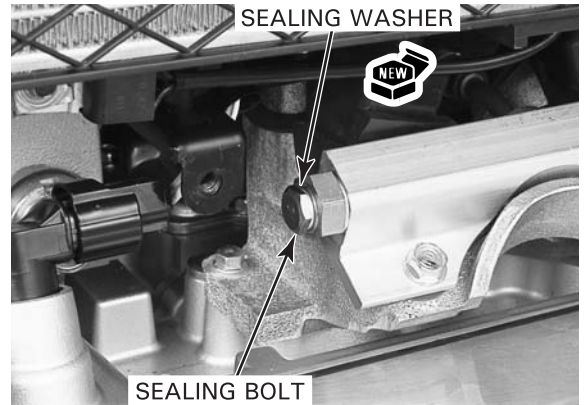

Turn the ignition switch to "ON" and check that there is no fuel leakage.

Remove the hose clamp from the pressure regulator vacuum hose.

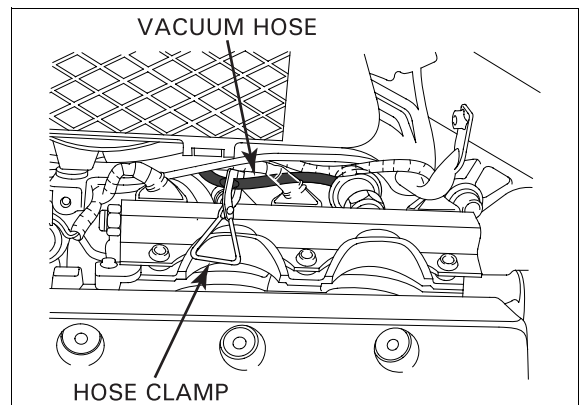

Install the left injector cover and tighten the two bolts securely.

Install the front fairing (page 2-10).



## FUEL SYSTEM (Programmed Fuel Injection)

### FUEL FLOW INSPECTION

Remove the seat (page 2-5).

*When the fuel return hose is disconnected, gasoline may spill out of the hose. Place an approved gasoline container under the hose and drain the gasoline. Wipe off any spilled gasoline.*

Disconnect the fuel return hose from the fuel tank and plug the joint pipe of the fuel tank immediately.

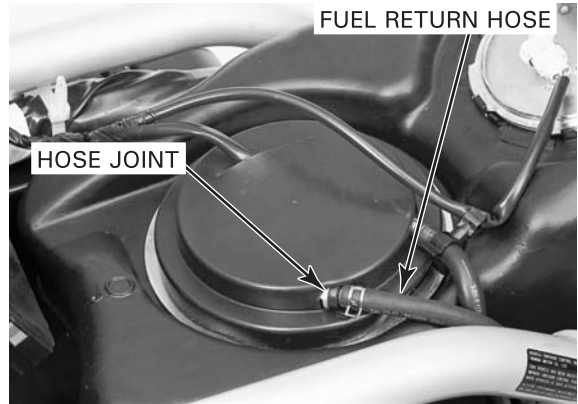

Place the end of the fuel return hose into an approved gasoline container.

Turn the ignition switch to "ON."

Turn the engine stop switch to "Q."

Wait until the fuel pump stops operating (listen for the sound of the pump to stop) (approximately 2 seconds).

Cycle the engine stop switch to "X" and then back to "Q."

Repeat this three more times (for a total of five times = 10 seconds).

Measure the amount of fuel volume pumped.

#### AMOUNT OF FUEL FLOW:

**Minimum 133 cm<sup>3</sup> (4.5 US oz, 4.7 Imp oz)/  
10 seconds**

If the fuel flow is less than the specified amount, inspect the following:

- clogged fuel feed hose and/or fuel return hose
- clogged fuel filter
- pressure regulator
- fuel pump

After inspection, connect the fuel return hose to the hose joint.

Turn the ignition switch to "ON" and check that there is no fuel leakage.

Install the seat (page 2-5).

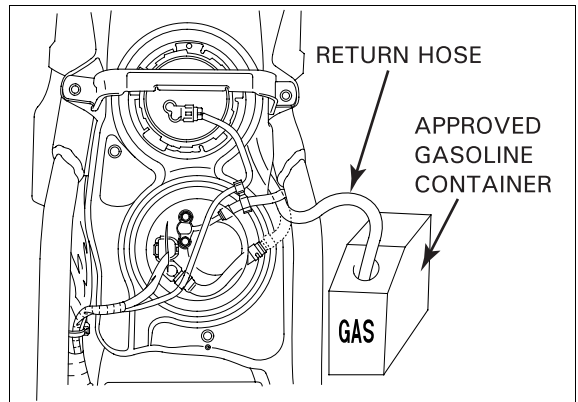

## FUEL PUMP

### INSPECTION

Remove the seat (page 2-5).

*Make sure the engine stop switch is turned to "Q."*

1. Turn the ignition switch to "ON" and check that the fuel pump operates for a few seconds.

- If the fuel pump operates, the system is OK.
- If the fuel pump does not operate, GO TO STEP 2.

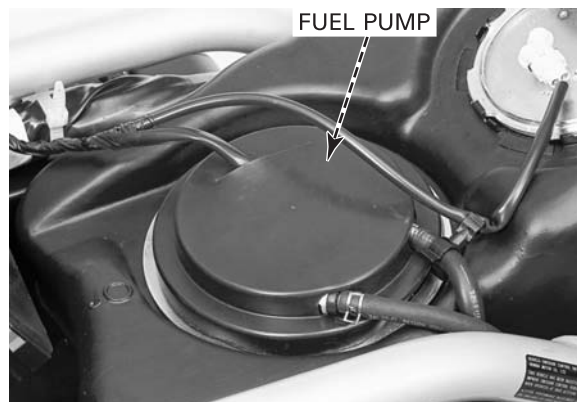



## FUEL SYSTEM (Programmed Fuel Injection)

2. Turn the ignition switch to "OFF" and disconnect the fuel pump 5P connector.  
Turn the ignition switch to "ON."  
Measure the voltage between the brown (+) and green (-) wire terminals of the wire harness side connector.  
There should be battery voltage for a few seconds.
  - If there is battery voltage, replace the fuel pump.
  - If there is no voltage, GO TO STEP 3.
3. Turn the ignition switch to "OFF."  
Check for an open circuit in the green wire between the fuel pump connector and ground terminal.  
Check for an open circuit in the brown wire between the fuel pump connector and fuel pump relay.
  - If the wires are OK, check the fuel pump relay circuit (page 5-66).

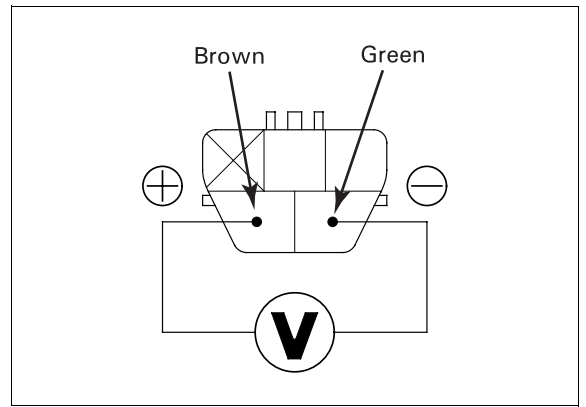

### REPLACEMENT

Be sure to wear safety glasses while performing this procedure.

Pull off the rubber cap.

Disconnect the 5P connector and fuel return hose from the fuel pump.

Remove the two fuel feed hose joint bolts.

Cover the fuel feed hose joint with a rag or shop towel.

Hold the flats of the hose joint and pull it up straight, being careful not to damage the fuel pump joint.

Catch the fuel using an approved gasoline container.

Remove the rubber cap.

Remove the fuel pump retainer ring by turning it counterclockwise with the special tool.

#### TOOL:

**Fuel sender/pump wrench**    **07ZMA-MCAA201 or 07ZMA-MCAA200**

Remove the retainer plate and fuel pump assembly from the fuel tank.

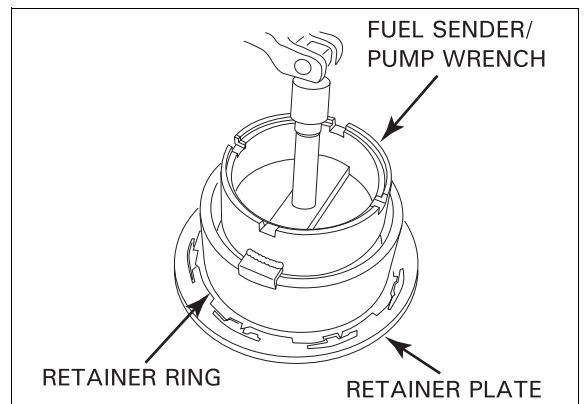
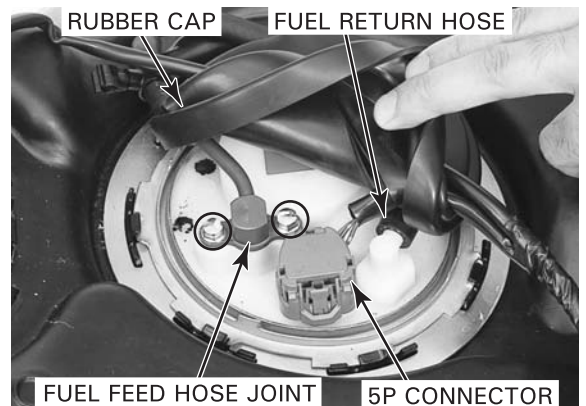



## FUEL SYSTEM (Programmed Fuel Injection)

Remove the base gasket.

Install a new base gasket.

Install the fuel pump assembly into the fuel tank and align the lugs on the pump base with the grooves in the fuel tank.

Install the retainer plate and a new retainer ring.

Turn the retainer ring clockwise with the special tool until it stops.

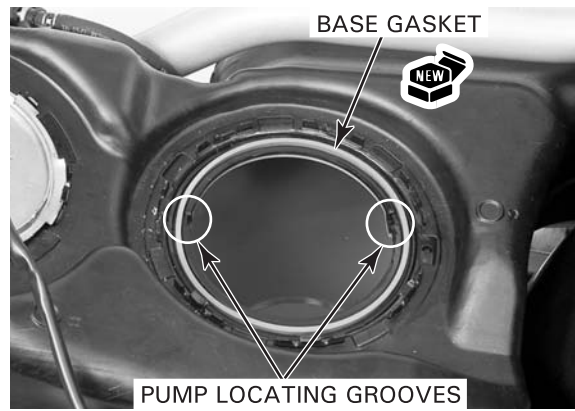

Coat a new O-ring with engine oil and install it into the fuel feed hose joint groove properly.

Install the hose joint into the fuel pump by pushing it straight, being careful not to damage the fuel pump joint.

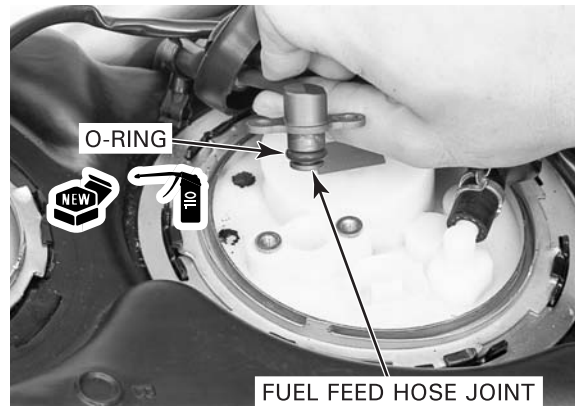

*Do not over-tighten the joint bolts.*

Install and tighten the hose joint bolts.

**TORQUE: 10 N·m (1.0 kgf·m, 7 lbf·ft)**

Connect the fuel return hose and 5P connector to the fuel pump.

Turn the ignition switch to "ON" and check that there is no fuel leakage.

Install the rubber cap over the fuel pump properly.

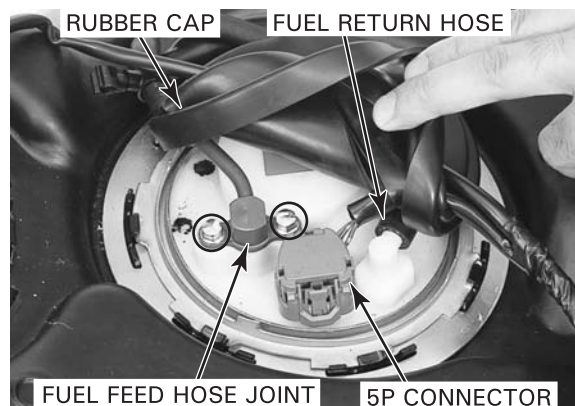

## FUEL TANK

### REMOVAL/INSTALLATION

Remove the following:

- top shelter (page 2-11)
- battery (page 17-6)
- screw and fuse box
- connector holder
- bolt and battery case

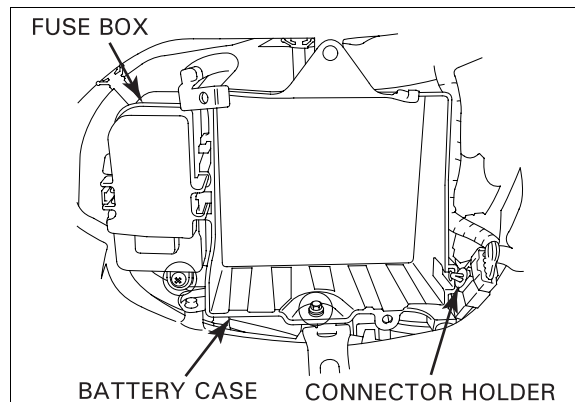

Tilt the fuel tank to the right and remove it from the left side of the motorcycle.

- Disconnect the following:
- fuel pump 5P connector (page 5-54)
  - fuel return hose (page 5-54)
  - fuel feed hose (page 5-54)
  - fuel level sensor 2P connector
  - fuel tank tray drain hose
  - fuel tank breather hose

Remove the four bolts, two washers, seat hook and fuel tank.

Route the hoses and wires properly (page 1-23).

Install the fuel tank in the reverse order of removal.

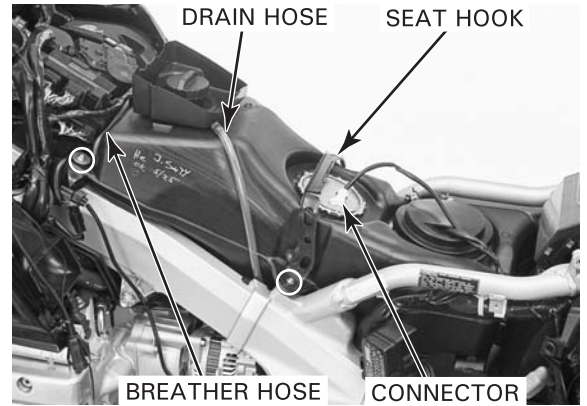

## AIR CLEANER HOUSING

### REMOVAL/INSTALLATION

Remove the following:

- air cleaner element (page 3-6)
- fuel tank (page 5-56)

Disconnect the crankcase breather hoses from the air cleaner housing.

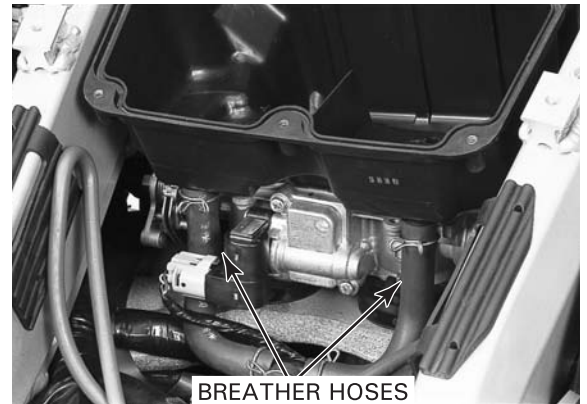

Remove the four screws attaching the air funnels and air cleaner housing from the throttle body.

NOTE:

- The screws cannot be removed from the air funnels at this time.

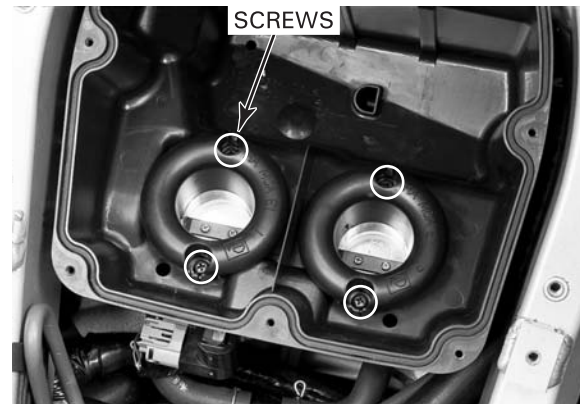

Disconnect the air cleaner housing drain hose and pulse secondary air supply hose and remove the air cleaner housing.

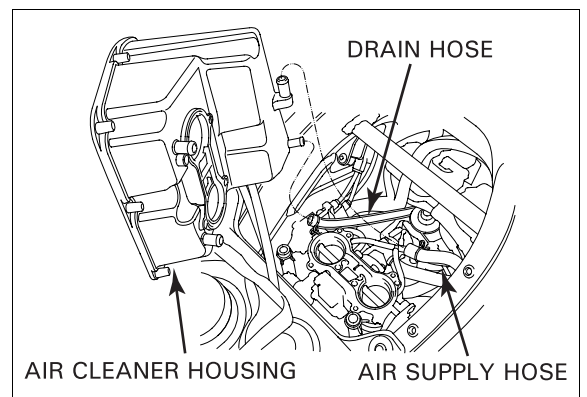

## FUEL SYSTEM (Programmed Fuel Injection)

To remove the air funnels, remove the screws from the air funnels and turn the air funnels as shown and remove them.

**NOTE:**

- The left air funnel has an "L" mark and the right air funnel has an "R" mark. Do not interchange them.

Install the air cleaner housing in the reverse order of removal.

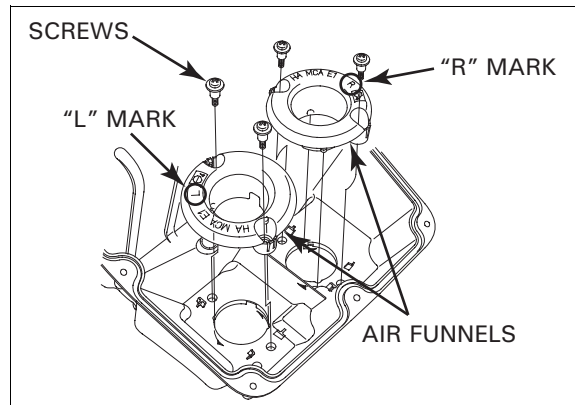

## THROTTLE BODY

### REMOVAL

Remove the following:

- air cleaner housing (page 5-57)
- both radiators (page 6-8)

Loosen the insulator band screws and remove the throttle body from the insulators.

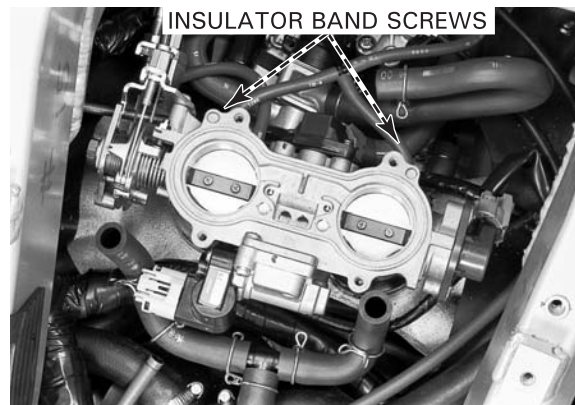

Disconnect the following:

- Evaporative emission (EVAP) No. 5 hoses
- pressure regulator vacuum hose
- MAP sensor connector
- TP sensor connector
- IAC valve connector

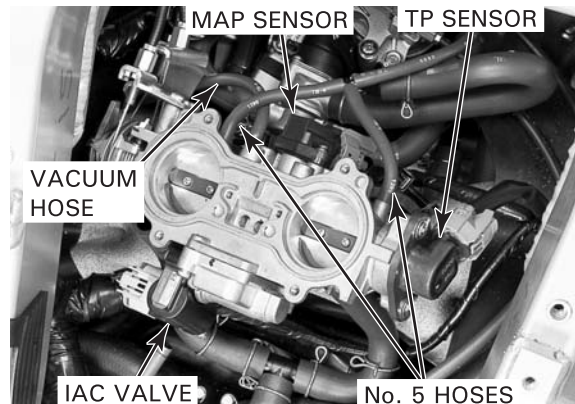

Remove the cruise actuator cable from the cable stay, and disconnect it from the actuator drum.

Remove the throttle cables from the cable stay and disconnect them from the throttle drum.

Remove the throttle body.

Seal the intake manifold ports with tape or a clean cloth to keep dirt and debris from entering the engine.

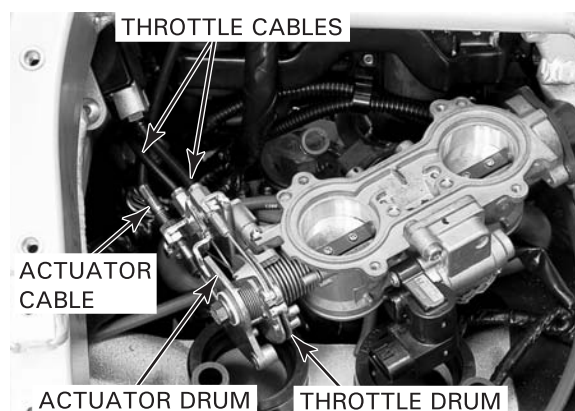

### DISASSEMBLY/ASSEMBLY

- Do not loosen or tighten the white painted bolts, nuts and screws of the throttle body. Loosening or tightening them can cause throttle and idle valve synchronization failure.
- The parts of the throttle body not shown in this manual should not be disassembled.

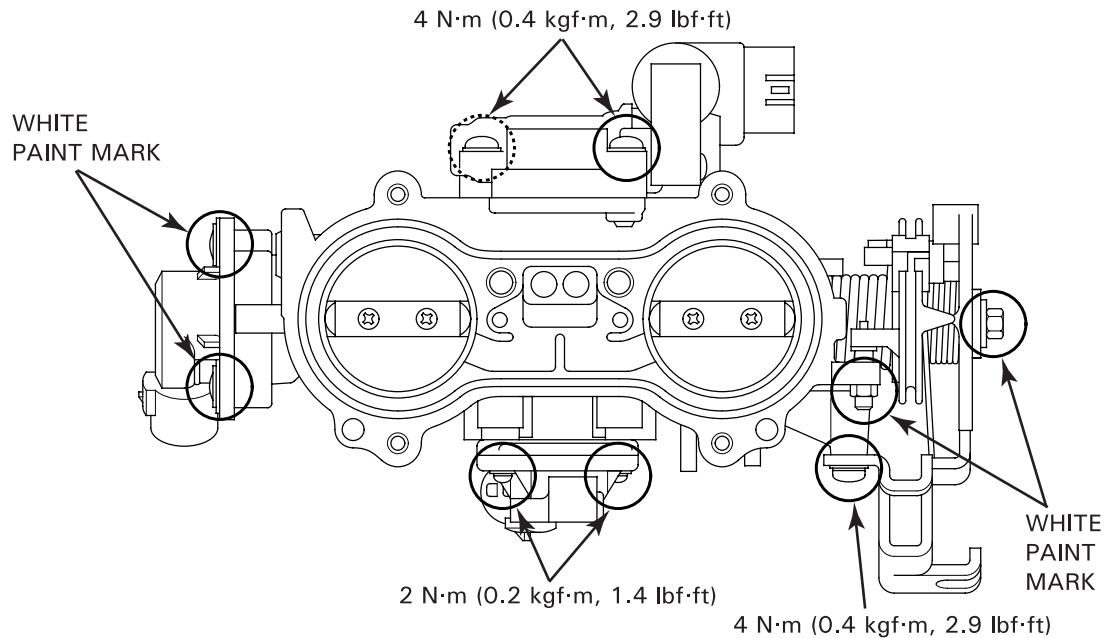

### IAC VALVE

Remove the two screws, IAC valve and seal rubber.

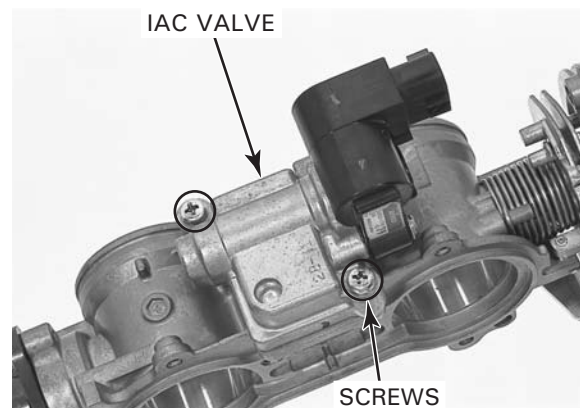

Install a new seal rubber into the throttle body groove.

Install the IAC valve and tighten the screws.

**TORQUE: 4 N·m (0.4 kgf·m, 2.9 lbf·ft)**





## FUEL SYSTEM (Programmed Fuel Injection)

### CABLE STAY/MAP SENSOR

Remove the two screws and cable stay.

Remove the two screws, MAP sensor and O-ring.

Install the cable stay and tighten the screws.

**TORQUE: 4 N·m (0.4 kgf·m, 2.9 lbf·ft)**

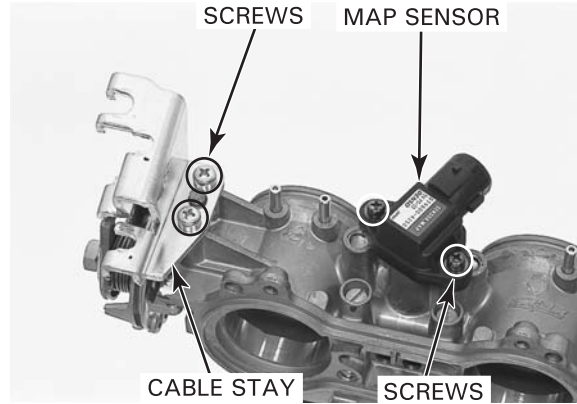

Install a new O-ring into the throttle body groove.

Install the MAP sensor and tighten the screws.

**TORQUE: 2 N·m (0.2 kgf·m, 1.4 lbf·ft)**

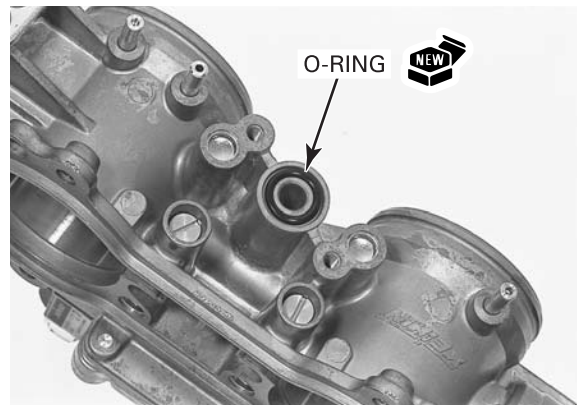

### INSTALLATION

Make sure the insulators and bands are installed properly as shown.

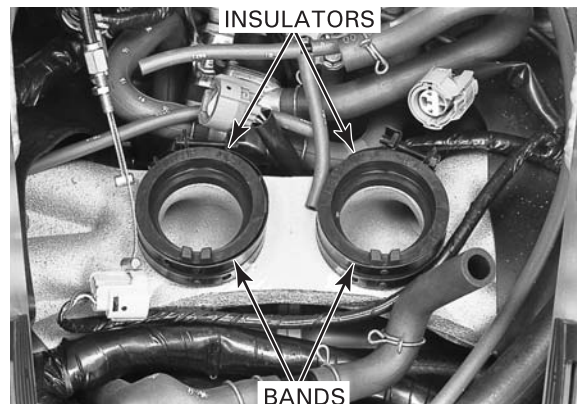

Connect the throttle cables to the throttle drum and install them onto the cable stay.

Screw in the throttle cable end bolts fully and tighten them.

Connect the cruise actuator cable to the actuator drum and install it onto the cable stay.

Adjust the cable position with the nuts so that the distance between the cable cap screw end and stay is 34 mm (1.34 in) as shown.

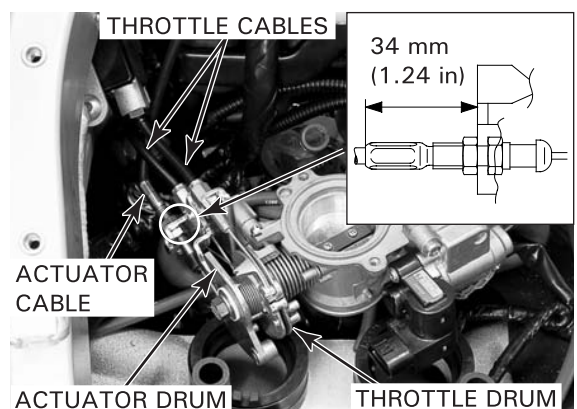

## FUEL SYSTEM (Programmed Fuel Injection)

Connect the hoses to their correct joint pipes.

Connect the following:

- Evaporative emission (EVAP) No. 5 hoses
- pressure regulator vacuum hose
- MAP sensor connector
- TP sensor connector
- IAC valve connector

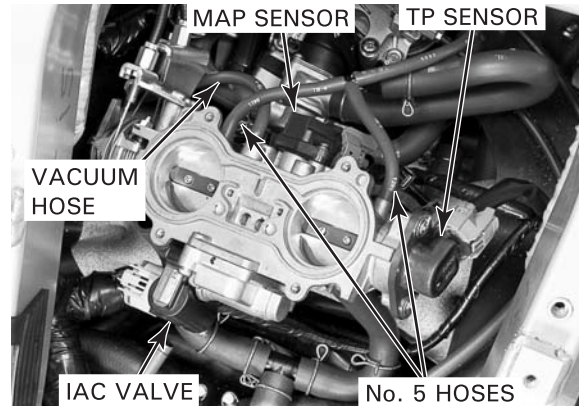

Install the throttle body into the insulator while aligning the lugs with the groove of the insulators.

Tighten the insulator band screws so that the distance between the band tabs is  $12 \pm 1$  mm ( $0.47 \pm 0.04$  in).

Check the following and adjust if necessary:

- throttle cable (page 3-5)
- cruise actuator cable (page 21-16)

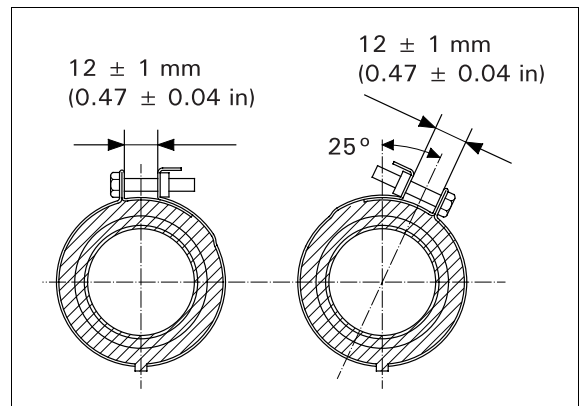

## FUEL INJECTORS

### INSPECTION

Remove the injector covers (page 5-61).

Start the engine and let it idle.

Confirm proper injector operation with a sounding rod or stethoscope.

If any injector does not operate, replace it.

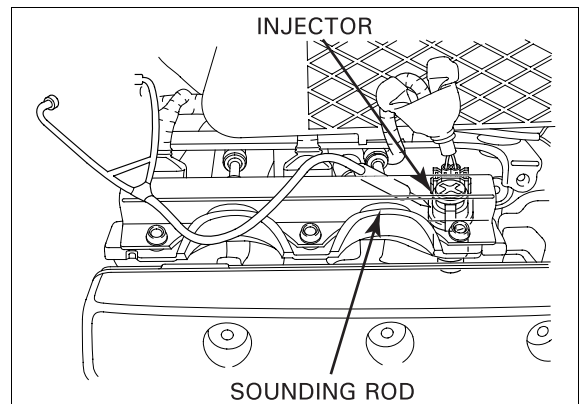

### REMOVAL

Remove the radiator (page 6-8).

Remove the two bolts and injector cover.

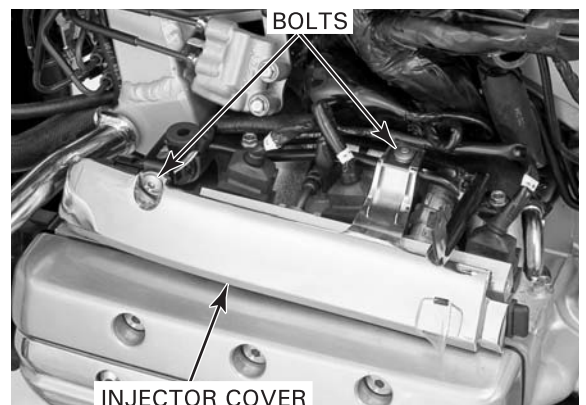

## FUEL SYSTEM (Programmed Fuel Injection)

Cover the sealing bolt with a rag or shop towel.  
Remove the sealing bolt to relieve the fuel pressure.  
Remove the two bolts and radiator stay.

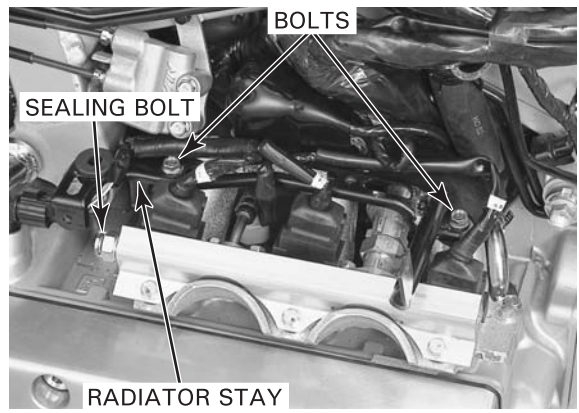

Disconnect the injector connectors.

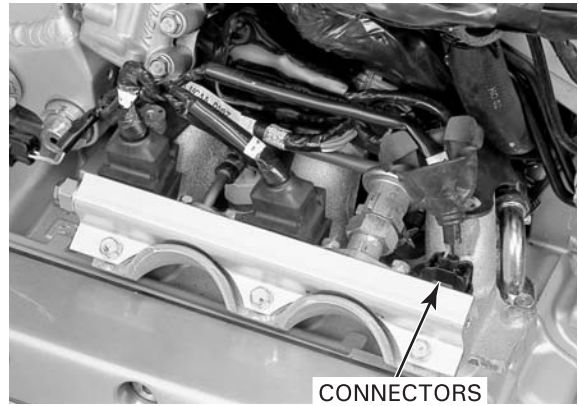

Left side: Remove the four bolts, fuel feed hose joint and pressure regulator stay from the fuel rail.

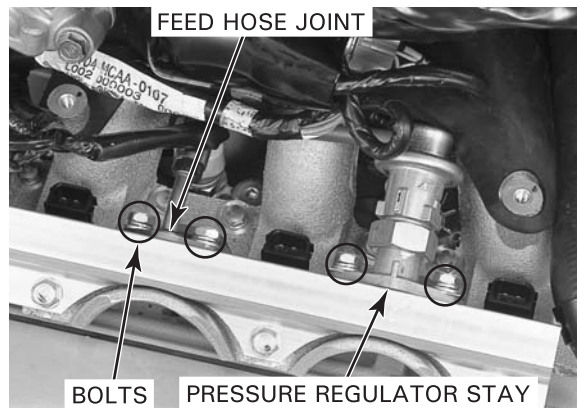

Right side: Remove the four bolts and fuel feed hose joints.

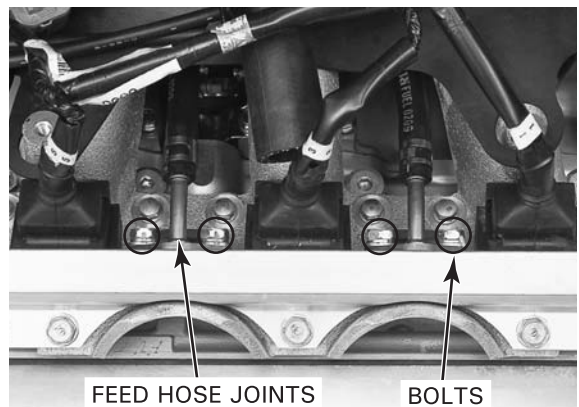

## FUEL SYSTEM (Programmed Fuel Injection)

Clean around the injectors with compressed air before removing the fuel rail assembly.

Remove the three bolts and fuel rail assembly from the intake manifold.

Seal the injector ports in the intake manifold with tape or clean cloth to keep dirt and debris from entering the engine.

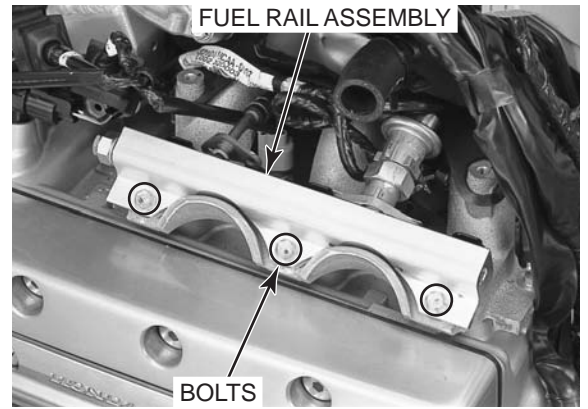

Remove the injector clips and injectors from the fuel rail.

Remove the O-rings from the injectors.

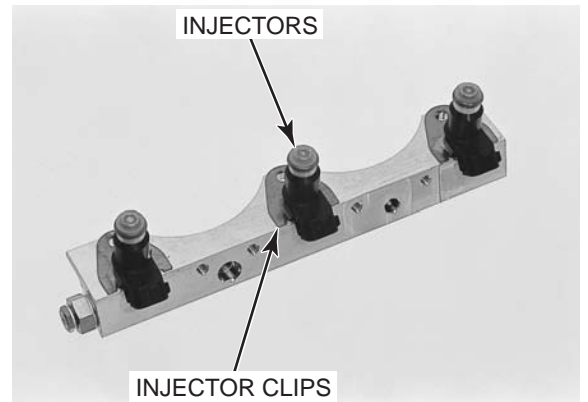

### INSTALLATION

Coat new O-rings with oil and install them into the injector grooves.

Install the injectors into the fuel rail.

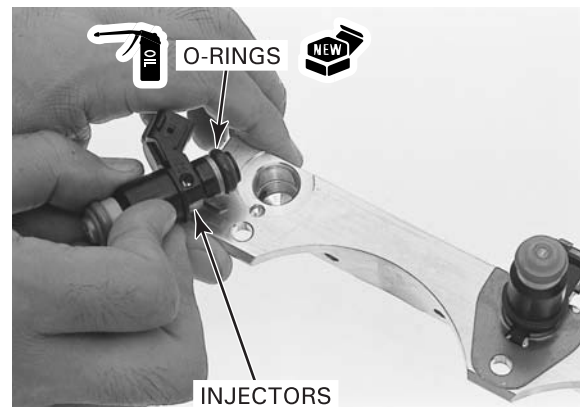

Install the injector clips.

Coat new O-rings with oil and install them into the injector grooves.

Install the fuel rail assembly onto the intake manifold while inserting the injectors into the intake manifold.

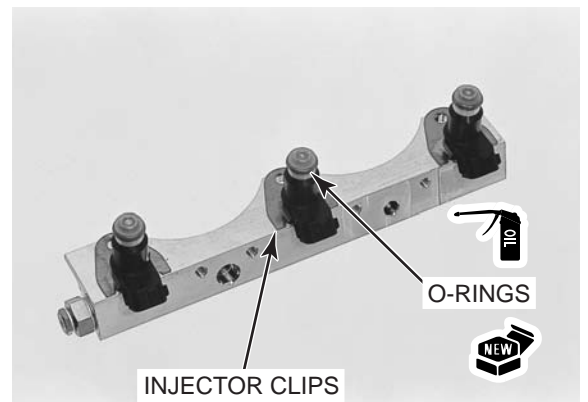



## FUEL SYSTEM (Programmed Fuel Injection)

Install the fuel rail mounting bolts and tighten them.

**TORQUE: 10 N·m (1.0 kgf·m, 7 lbf·ft)**

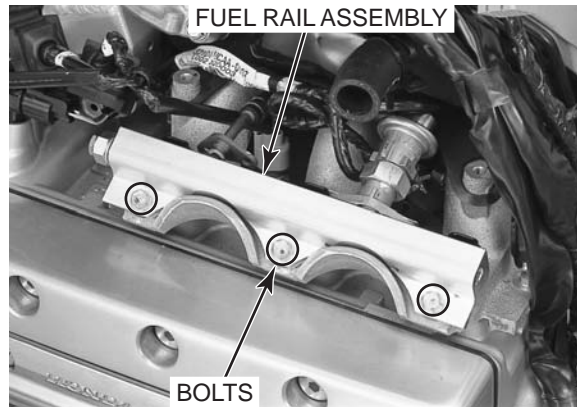

Left side:

Coat new O-rings with oil and install them into the fuel feed hose joint and pressure regulator stay.

Right side:

Right side: Coat new O-rings with oil and install them into the fuel feed hose joints.



Left side:

Install the fuel feed hose joint and pressure regulator stay onto the fuel rail.

Install and tighten the joint bolts.

**TORQUE: 10 N·m (1.0 kgf·m, 7 lbf·ft)**

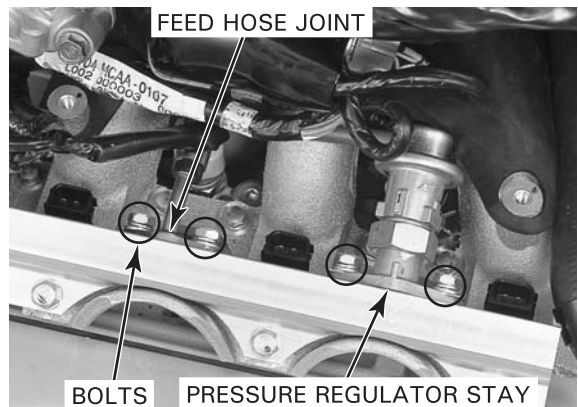

Right side:

Install the fuel feed hose joints onto the fuel rail.

Install and tighten the joint bolts.

**TORQUE: 10 N·m (1.0 kgf·m, 7 lbf·ft)**

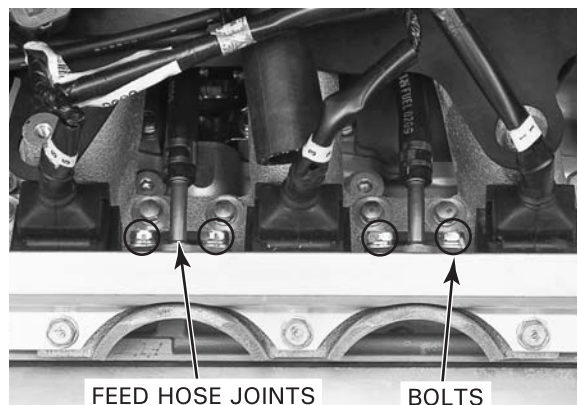

### PRESSURE REGULATOR REPLACEMENT

Remove the radiator stay (page 5-61).

Hold the pressure regulator and loosen the nut.

Remove the pressure regulator and joint pipe from the pressure regulator stay.

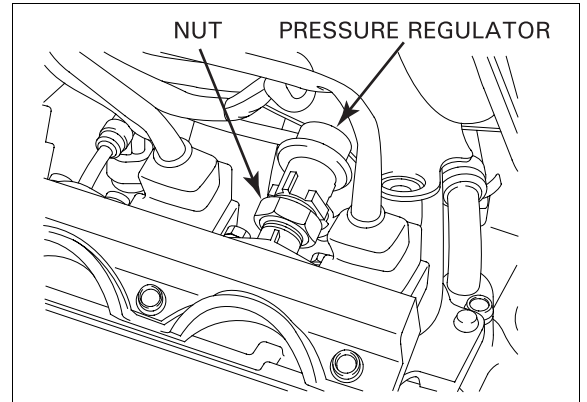

Disconnect the vacuum hose and fuel return hose from the pressure regulator.

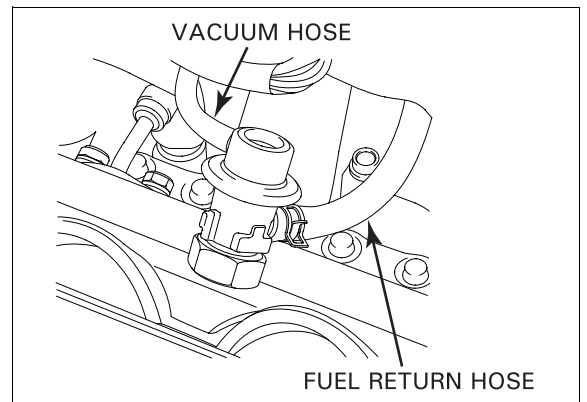

Remove the O-rings from the joint pipe.

Coat the new O-rings with oil and install them onto the joint pipe.

Install the joint pipe into the pressure regulator stay.

Connect the fuel return hose and vacuum hose onto the pressure regulator.

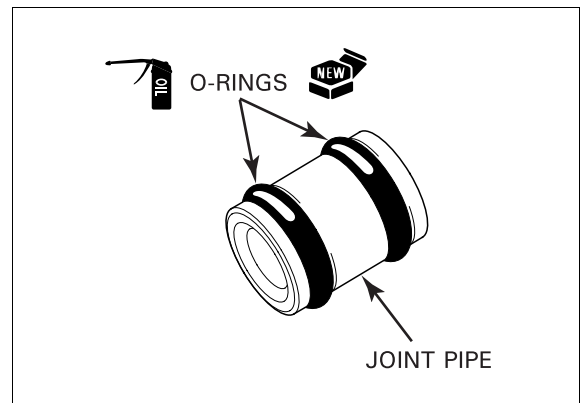

Install the pressure regulator onto the stay and tighten the nut by hand.

Align the index lugs on the pressure regulator and stay, and tighten the nut while holding the regulator.

**TORQUE: 27 N·m (2.8 kgf·m, 20 lbf·ft)**

Install the removed parts in the reverse order of removal.

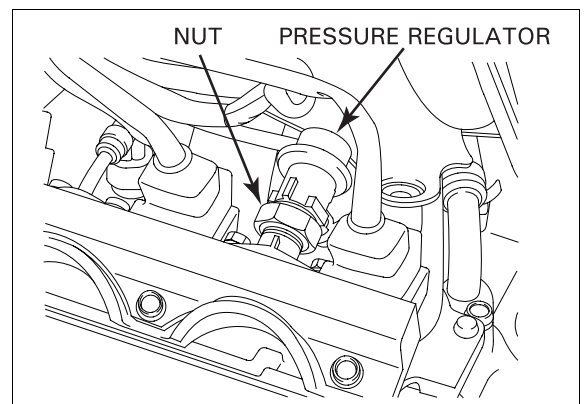

## FUEL SYSTEM (Programmed Fuel Injection)

# FUEL PUMP RELAY

### SYSTEM INSPECTION

#### NOTE:

- Perform the fuel pump inspection (page 5-54) before this inspection.

Remove the seat (page 2-5).

Remove the two screws and remove the relay box.  
Remove the relay blocks from the relay box.

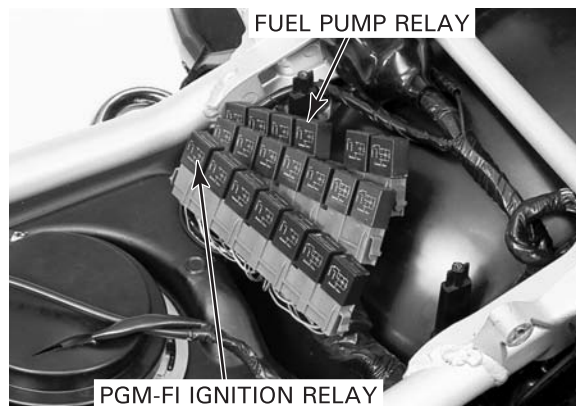

*Make sure the engine stop switch is turned to "O."*

1. Turn the ignition switch to "OFF" and exchange the fuel pump relay with a known-good one. Turn the ignition switch to "ON" and check that the fuel pump operates for a few seconds.
  - If the fuel pump operates, replace the fuel pump relay with a new one.
  - If the pump does not operate, GO TO STEP 2.

2. Turn the ignition switch to "OFF" and remove the fuel pump relay. Turn the ignition switch to "ON." Measure the voltage between the Black/yellow wire terminal (+) of the relay connector and ground (-). There should be battery voltage.

- If there is no voltage, GO TO STEP 3.
- If there is battery voltage, GO TO STEP 4.

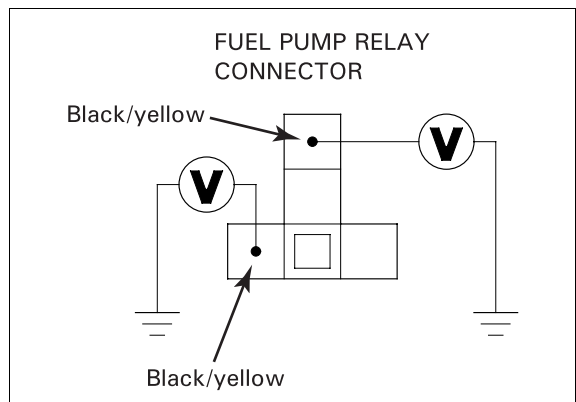

3. Turn the ignition switch to "OFF" and remove the PGM-FI ignition relay. Check for continuity between the Black/yellow wire terminals of the fuel pump relay and PGM-FI ignition relay connectors. There should be continuity.

- If there is no continuity, repair the open circuit in the Black/yellow wire.
- If there is continuity, check the PGM-FI ignition relay circuits (page 18-11).

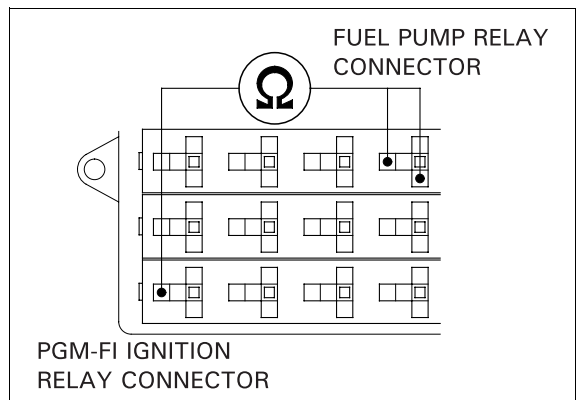

4. Turn the ignition switch to "OFF."  
Measure the voltage between the Black/yellow wire terminal (+) and Brown/black wire terminal of the fuel pump relay connector.  
Turn the ignition switch to "ON."  
There should be battery voltage for a few seconds.
  - If there is battery voltage for a few seconds, the system is OK; check for loose contacts or corroded terminals.
  - If there is no voltage, GO TO STEP 5.

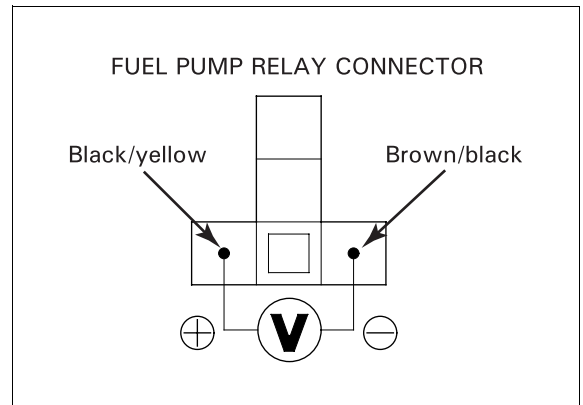

5. Turn the ignition switch to "OFF."  
Remove the top shelter (page 2-11).  
Disconnect the ECM 22P black connector.  
Check the connector for loose contacts or corroded terminals.  
Check for continuity between the Brown/black wire terminals of the fuel pump relay and ECM 22P black connectors.  
There should be continuity.
  - If there is no continuity, repair the open circuit in the Brown/black wire.
  - If there is continuity, replace the ECM with a new one and inspect again.

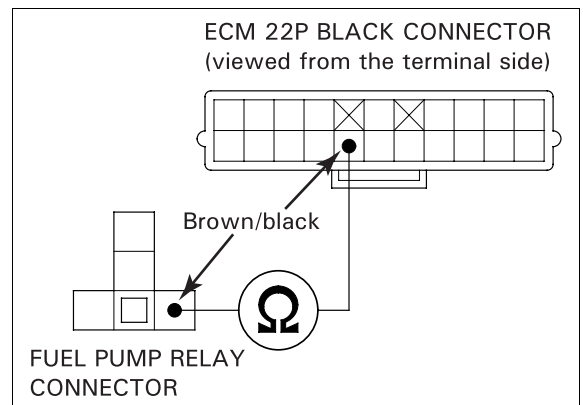

## BARO/MAP SENSORS

### OUTPUT VOLTAGE INSPECTION

Connect the ECM test harness to the ECM connectors (page 5-11).

Turn the ignition switch to "ON" and engine stop switch to "C."

Measure the voltage at the ECM test harness connector terminals (page 5-11).

#### CONNECTION:

**BARO sensor: B15 (+) – C4 (-)**

**MAP sensor: B4 (+) – C4 (-)**

#### STANDARD: 2.7 – 3.1 V

The output voltage (above) is measured under the standard atmosphere (1 atm = 1,030 hPa).

The output voltage is changed by altitude as shown in the chart, because it varies in accordance with the atmospheric pressure.

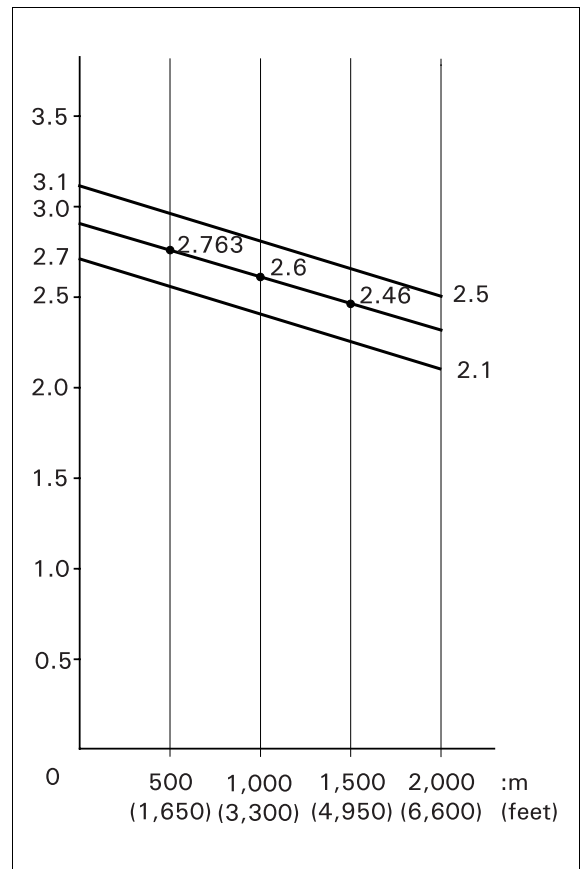

## FUEL SYSTEM (Programmed Fuel Injection)

### BARO SENSOR REPLACEMENT

Remove the top shelter (page 2-11).

Disconnect the BARO sensor 3P connector.

Remove the screw and BARO sensor.

Installation is in the reverse order of removal.

#### NOTE:

- For the MAP sensor, remove the throttle body (page 5-58) and replace the sensor (page 5-68).



## IAT SENSOR

### REPLACEMENT

Remove the control unit holder (page 3-6).

Disconnect the IAT sensor 2P connector.

Remove the IAT sensor from the grommet.

Installation is in the reverse order of removal.

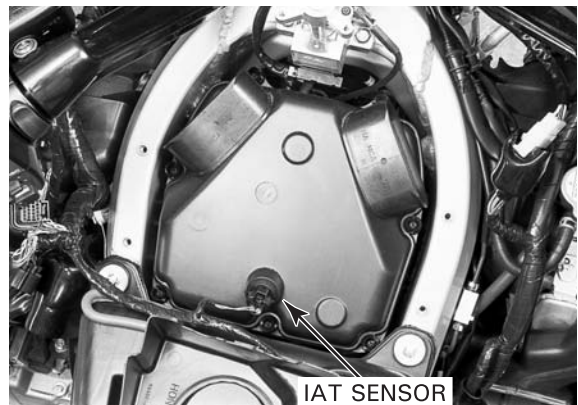

## CAMSHAFT POSITION SENSOR

### REPLACEMENT

Remove the injector cover (page 5-61).

Disconnect the camshaft position sensor 2P connector.

Remove the bolt and camshaft position sensor.

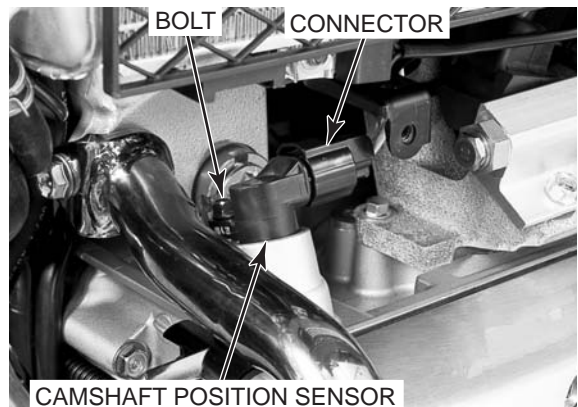



Coat a new O-ring with engine oil and install it onto a new camshaft position sensor.

Install the camshaft position sensor into the left cylinder head and tighten the bolt securely.

Install the injector cover (page 5-61).

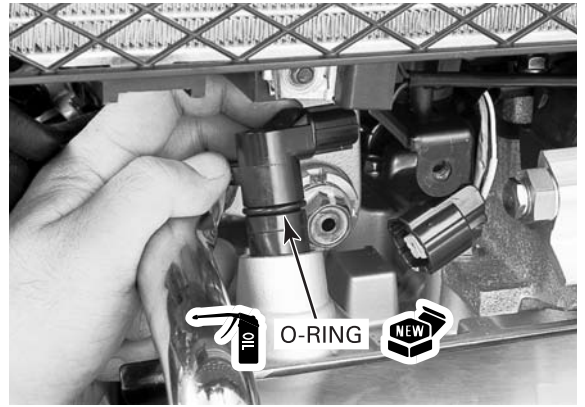

## O<sub>2</sub> SENSOR

### REPLACEMENT

Remove the top shelter (page 2-11).

Disconnect the O<sub>2</sub> sensor connector (page 2-18).

Remove the O<sub>2</sub> sensor from the exhaust pipe.

Install an new O<sub>2</sub> sensor and tighten it.

**TORQUE: 25 N·m (2.5 kgf·m, 18 lbf·ft)**

Connect the O<sub>2</sub> sensor connector (page 2-20).

Install the top shelter (page 2-12).

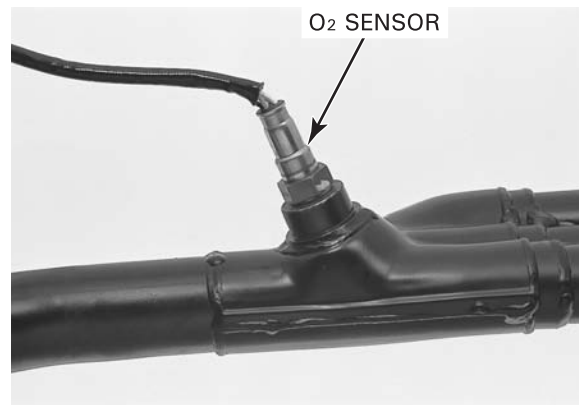

## KNOCK SENSOR

### REPLACEMENT

Remove the front exhaust pipe protector (page 2-18).

Remove the front lower fairing (page 2-6).

Disconnect the knock sensor 1P connector.

Remove the knock sensor from the cylinder.

Install a new knock sensor and tighten it.

**TORQUE: 31 N·m (3.2 kgf·m, 23 lbf·ft)**

Install the removed parts in the reverse order of removal.

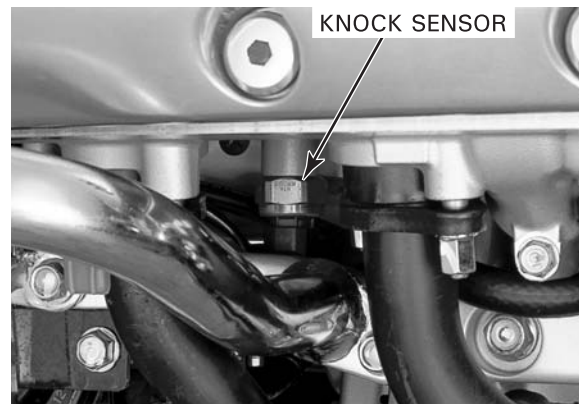

## **VEHICLE SPEED SENSOR**

### **REPLACEMENT**

Remove the following:

- top shelter (page 2-12)
- right front exhaust pipe protector (page 2-18)

Disconnect the vehicle speed sensor 3P connector.

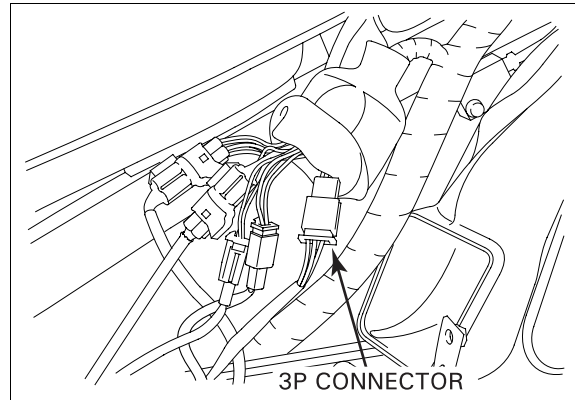

Remove the two bolts and the vehicle speed sensor from the crankcase.

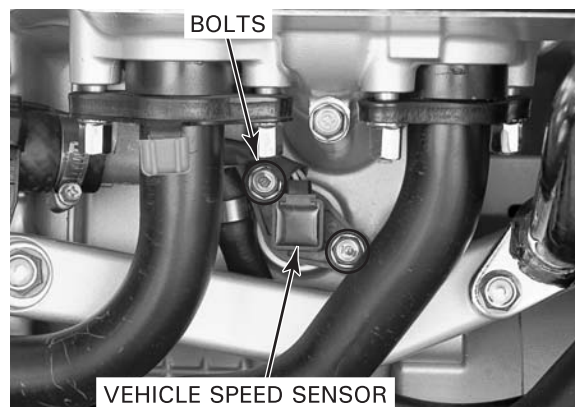

Coat a new O-ring with engine oil and install it onto a new vehicle speed sensor.

Install vehicle the speed sensor and tighten the bolts securely.

Route the vehicle speed sensor wire properly (page 1-23) and connect the connector.

Install the following:

- right front exhaust pipe protector (page 2-18)
- top shelter (page 2-12)

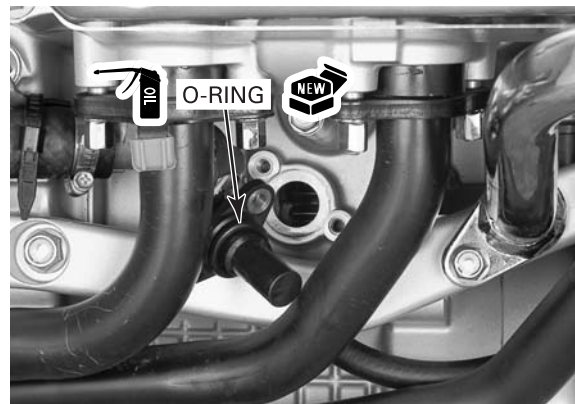

## ECM (ENGINE CONTROL MODULE)

### POWER/GROUND LINE INSPECTION

Connect the test harness set to the ECM connectors (page 5-11).

#### GROUND LINE

Check for continuity between the test pin box No. 9 terminal and ground, between the No. 19 terminal and ground, and between the No. 20 terminal and ground.

There should be continuity at all times.

If there is no continuity, check for an open circuit in the green wires.

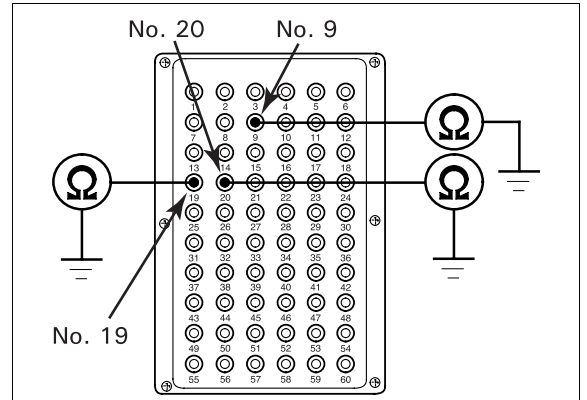

#### POWER INPUT LINE

Turn the ignition switch to "ON" with the engine stop switch turned to "O."

Measure the voltage between the test pin box No. 1 terminal and ground.

There should be battery voltage.

If there is no voltage, check for an open circuit in Black/yellow wire between the ECM and PGM-FI ignition relay.

If the wire is OK, check the PGM-FI ignition relay circuits (page 18-11).

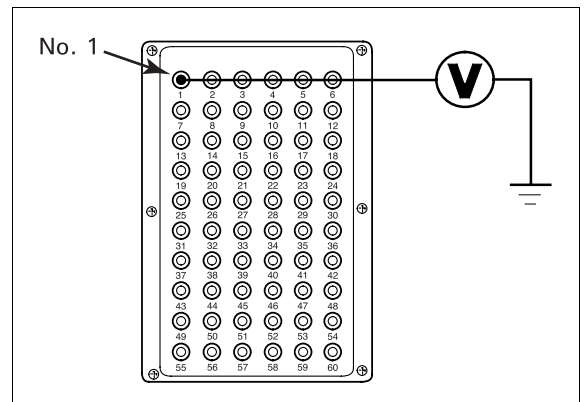

## SECONDARY AIR SUPPLY SYSTEM

### SYSTEM INSPECTION

Start the engine and warm it up to normal operating temperature.

Remove the air cleaner element (page 3-6).

Check that the secondary air intake port is clean and free of carbon deposits.

If there is carbon in the air intake port, check the pulse secondary air injection (PAIR) check valves.





## FUEL SYSTEM (Programmed Fuel Injection)

Remove the air cleaner housing (page 5-57).

Temporarily install the fuel tank.

Connect the ECM, IAT sensor and BARO sensor connectors.

Start the engine and open the throttle slightly to be certain that air is sucked in through the No. 15 air supply hose.

If air is not drawn in, check the air supply hoses for clogs and the PAIR control solenoid valve.

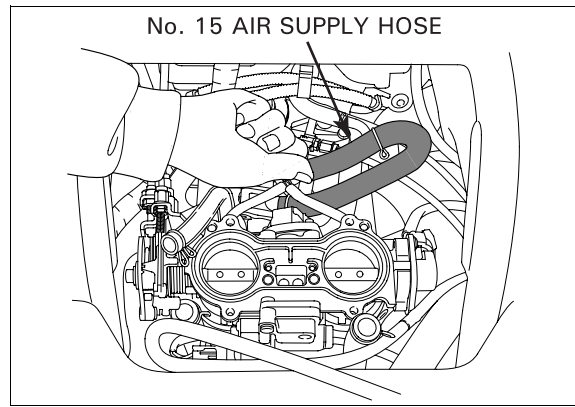

### PAIR CONTROL SOLENOID VALVE INSPECTION

Remove the air cleaner housing (page 5-57).

Disconnect the 2P connector and air supply hoses from the PAIR control solenoid valve and remove the solenoid valve.

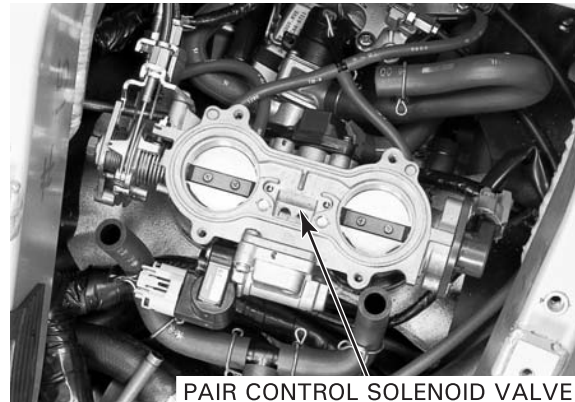

Check air flow from hose fitting (A) (input port) to hose fitting (B) (output port). Air should flow out.

Connect a 12-V battery to the solenoid valve connector.

#### CONNECTION:

**Battery (+) – Black/yellow wire terminal**

**Battery (–) – Orange/green wire terminal**

Air should not flow when the battery is connected.

Install the PAIR control solenoid valve in the reverse order of removal.

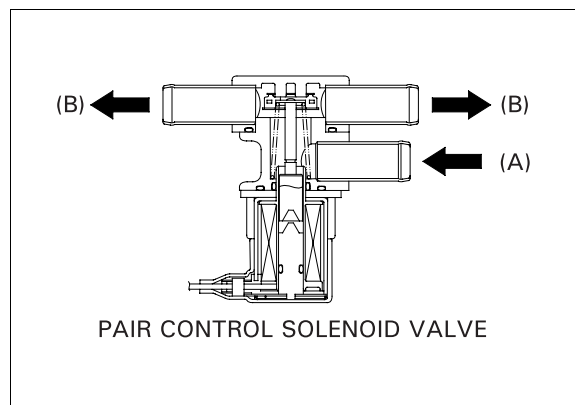

### PAIR CHECK VALVE REPLACEMENT

Remove the engine from the frame (section 7).

Remove the 12 bolts, intake manifold from the cylinder heads and gaskets.

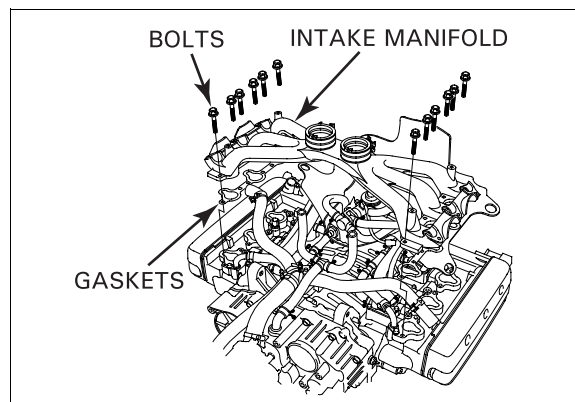

## FUEL SYSTEM (Programmed Fuel Injection)

Remove the six bolts and check valve covers/hoses from the cylinder.

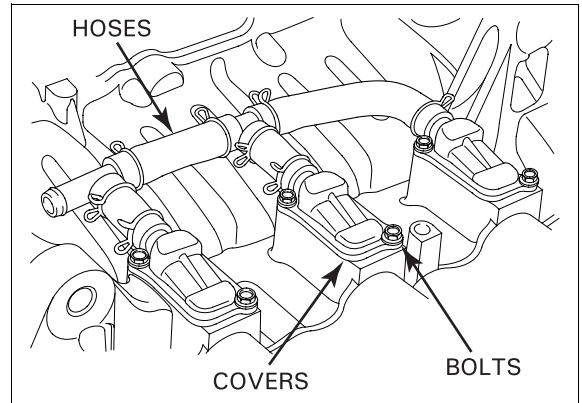

Remove the PAIR check valves from the cylinder.

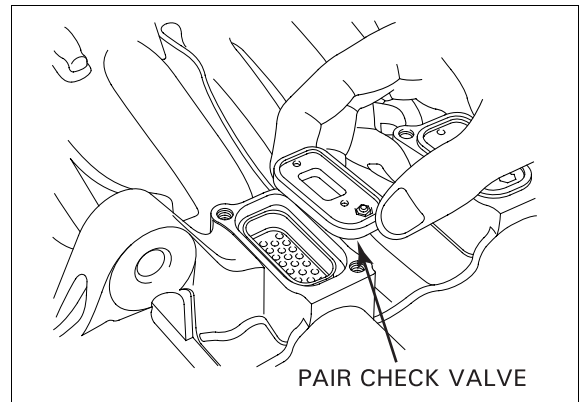

Check the reed for damage or fatigue. Replace if necessary.

Replace the PAIR check valve if the seat rubber is cracked, deteriorated or damaged, or if there is clearance between the reed and seat.

Install the PAIR check valve and cover onto the cylinder.

Install and tighten the bolts.

**TORQUE: 5 N·m (0.5 kgf·m, 3.6 lbf·ft)**

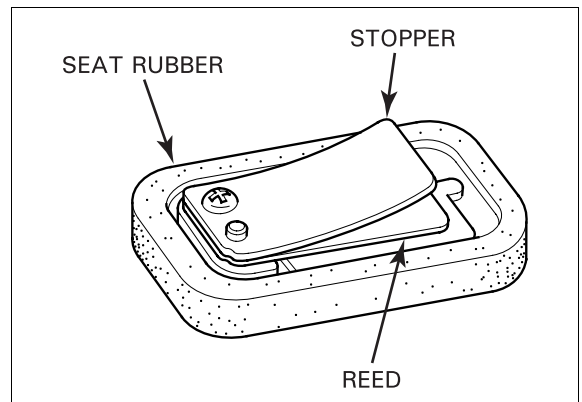

Install the intake manifold with new gaskets and tighten the bolts securely.

Install the engine (section 7).

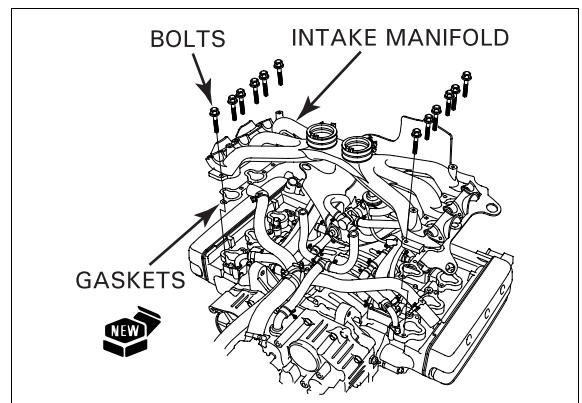

## FUEL SYSTEM (Programmed Fuel Injection)

# EVAPORATIVE EMISSION (EVAP) CONTROL SYSTEM

### NOTE:

- Refer to the Vacuum Hose Routing Diagram and Cable & Harness Routing (page 1-23) for hose connections and routing.

## EVAP CANISTER REMOVAL/INSTALLATION

Remove the front lower fairing (page 2-6).

Disconnect the No. 1 and No. 4 hoses from the EVAP canister.

Remove the two bolts and the EVAP canister bracket from the engine.

Remove the two bolts and the EVAP canister from the bracket.

Install the EVAP canister in the reverse order of removal.

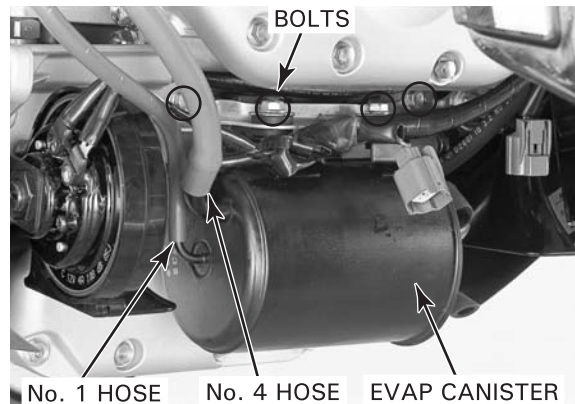

## EVAP PURGE CONTROL SOLENOID VALVE INSPECTION

Remove the center inner fairing (page 2-10).

Disconnect the 2P connector, No. 4 and No. 5 hoses from the EVAP purge control solenoid valve.

Remove the EVAP purge control solenoid valve from the stay.

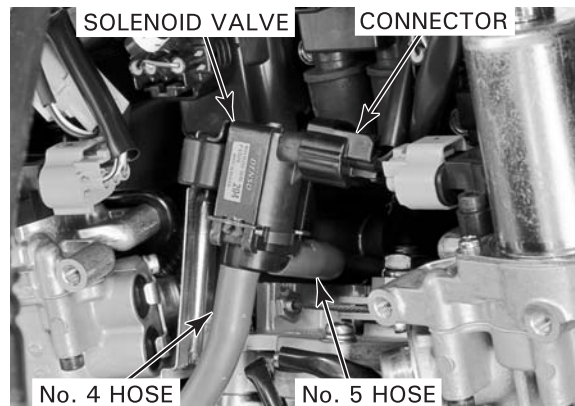

Check the air flow from hose fitting A (input port) to hose fitting B (output port).

Air should not flow.

Connect a 12-V battery to the solenoid valve connector.

### CONNECTION:

**Battery (+) – Black/yellow terminal**

**Battery (–) – Yellow/black terminal**

Air should flow out when the battery is connected.

Install the EVAP purge control solenoid valve in the reverse order of removal.

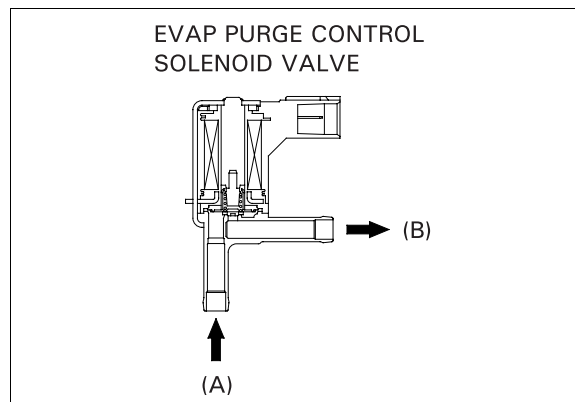

## ENGINE IDLE SPEED

**NOTE:**

- Make sure the malfunction indicator (MIL) does not indicate any failure codes before inspecting the engine idle speed.

Shift the transmission into neutral and place the motorcycle on its center stand on a level surface. Start the engine, warm it up to the normal operating temperature and let it idle.

**ENGINE IDLE SPEED: 700 ± 70 rpm**

- If the idle speed is lower than 630 rpm, see page 5-75.
- If the idle speed is higher than 770 rpm, see page 5-75.

### LOW ENGINE IDLE SPEED

**NOTE:**

- Make sure the charging system is in good condition before proceeding.

1. Turn the ignition switch to "OFF" and disconnect the ECM 22P black connector and alternator 4P connector. Check for continuity between the Black wire terminals of the ECM and alternator connectors.
  - If there is continuity, GO TO STEP 2.
  - If there is no continuity, repair the black wire.
2. Remove the air cleaner housing (page 5-57). Temporarily install the fuel tank. Connect the ECM, IAT sensor and BARO sensor connectors.

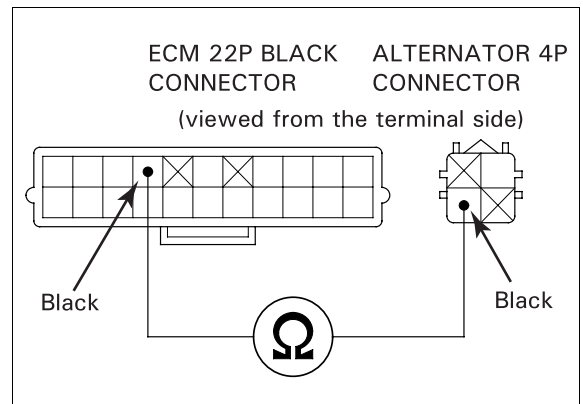

3. Start the engine, warm it up to normal operating temperature and let it idle. Disconnect the idle air control (IAC) valve 3P connector. Block the air passages in the throttle body with tape and check that the idle speed decreases.

- If the idle speed does not decrease, replace the IAC valve.
- If the idle speed decreases, turn out both air screws an equal number of turns to raise the idle speed to the specification.

**IDLE SPEED: 500 – 600 rpm**

If the idle speed does not fall within the specification, remove the throttle body (page 5-58), remove the air screws and clean the air screw passages.

*Do not turn the air screws out more than 3-1/2 turns from the fully closed position.*

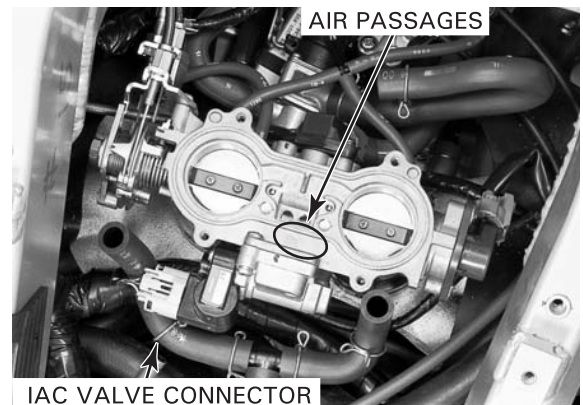

## FUEL SYSTEM (Programmed Fuel Injection)

### HIGH ENGINE IDLE SPEED

#### NOTE:

- Make sure that the charging system is in good condition before proceeding.
1. Stop the engine and allow it to cool until the coolant temperature gauge needle moves below the "C" line.
  2. Start the engine and let it idle.  
When the radiator cooling fan comes on, stop the engine and restart it.  
After 10 – 20 seconds, check the idle speed.

#### IDLE SPEED: 700 ± 70 rpm

- If the idle speed is within the specification, the system is OK.
- If the idle speed is higher than the specification, GO TO STEP 3.

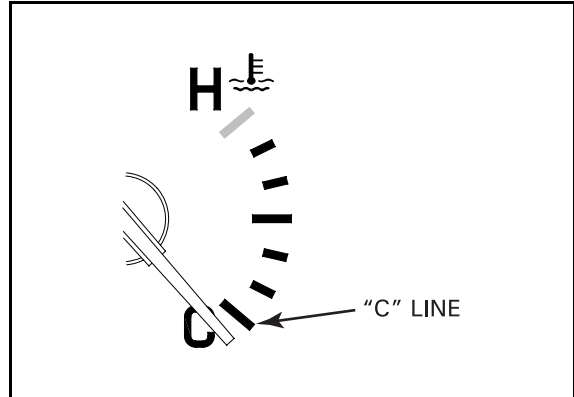

3. Stop the engine and remove the air cleaner housing (page 5-57).  
Check that the No. 5 hoses are connected to the throttle body and purge control solenoid valve, and the vacuum hose is connected to the throttle body and pressure regulator securely.  
Connect the loose hose securely or replace the damaged hose with a new one as necessary.  
Connect the loose hose securely or replace the damaged hose with a new one as necessary.

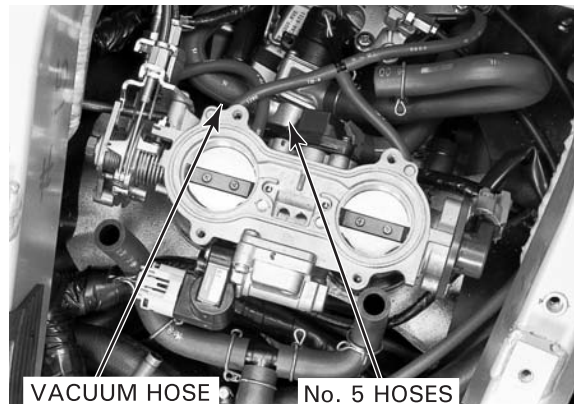

4. Disconnect the IAC valve 3P connector.  
Temporarily install the fuel tank.  
Connect the ECM, IAT sensor and BARO sensor connectors.  
Start the engine, warm it up to normal operating temperature and let it idle.  
Block the air passages in the throttle body with tape and check the idle speed.

#### IDLE SPEED: 500 – 600 rpm

- If the idle speed is within the specification, GO TO STEP 6.
- If the idle speed is higher than the specification, GO TO STEP 5.

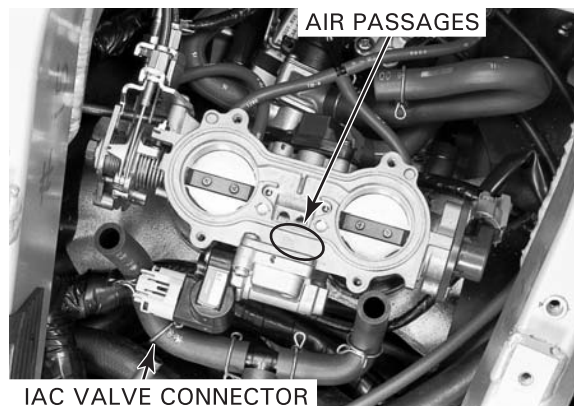

5. Turn both air screws in an equal number of turns to correct the idle speed.
  - If the air screws are fully closed but the idle speed does not fall within the specification, replace the throttle body with a new one (page 5-58).
  - If the idle speed falls within the specification, GO TO STEP 6.

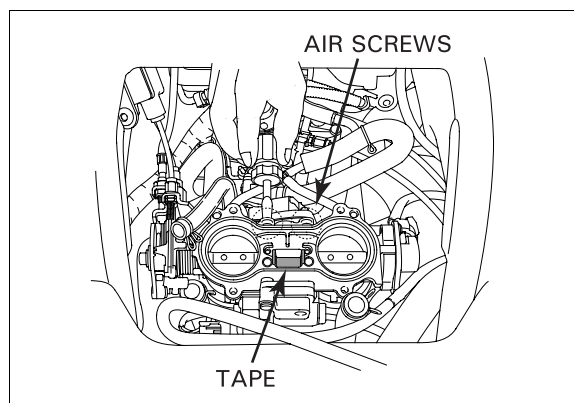

6. Stop the engine, and remove the tape from the throttle body.  
Start the engine and check the idle speed.

**IDLE SPEED: 1,500 – 1,600 rpm**

- If the idle speed is out of specification, replace the IAC valve.
- If the idle speed is within the specification, GO TO STEP 7.

7. Stop the engine and connect the IAC valve 3P connector.  
Start the engine and check the idle speed.

**IDLE SPEED: 700 ±70 rpm**

- If the idle speed is higher than specification, replace the IAC valve.
- If the idle speed is within specification, the system is OK.

---

**MEMO**

---

# 6. COOLING SYSTEM

---

**COMPONENT LOCATION** ..... 6-2

**SERVICE INFORMATION** ..... 6-3

**TROUBLESHOOTING** ..... 6-4

**SYSTEM TESTING**..... 6-5

**COOLANT REPLACEMENT**.....6-6

**RADIATOR/COOLING FAN**.....6-8

**WATER PUMP/THERMOSTAT**.....6-17



# COOLING SYSTEM

## COMPONENT LOCATION

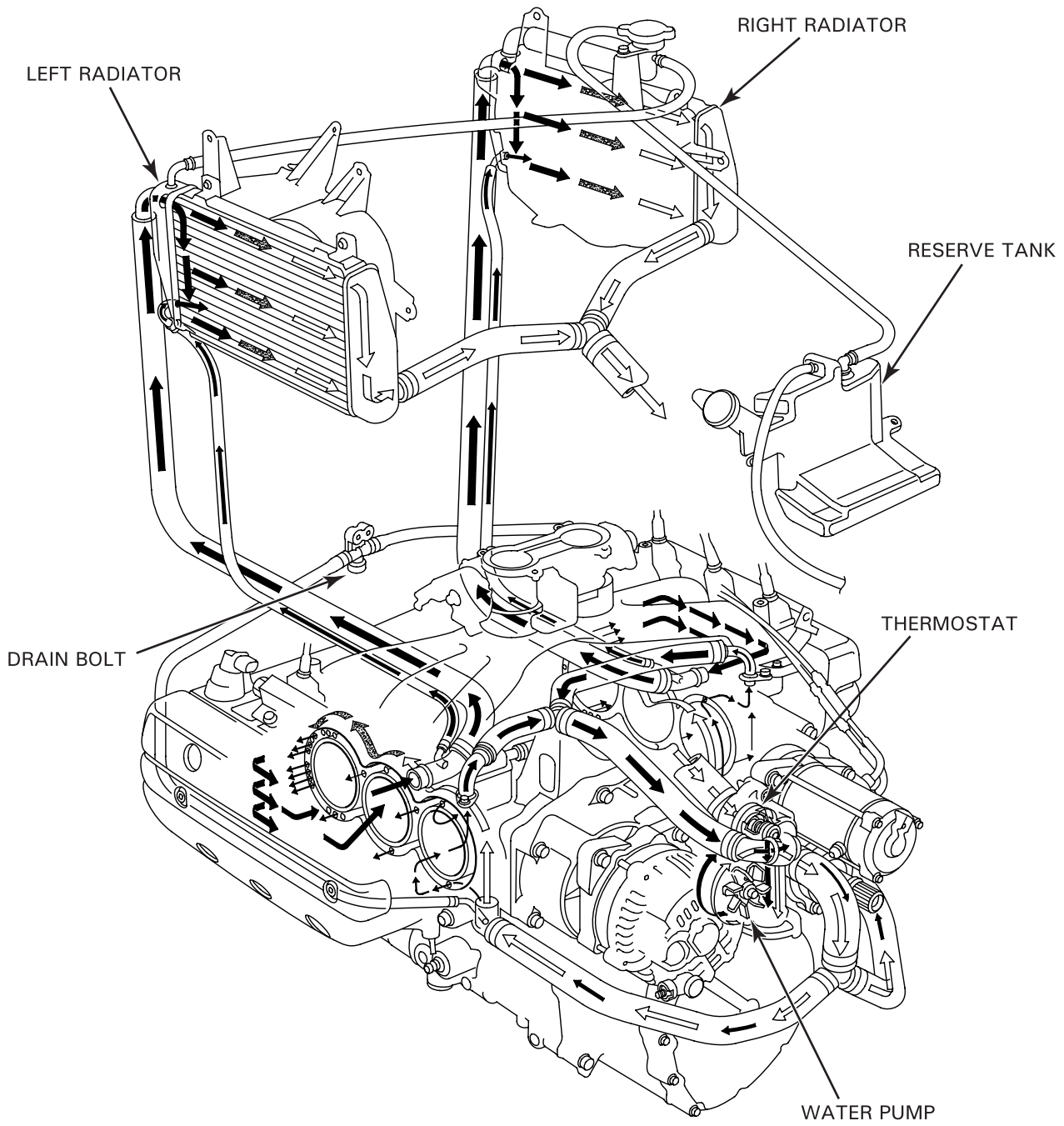

## SERVICE INFORMATION

### GENERAL

#### ⚠ WARNING

Removing the radiator cap while the engine is hot can allow the coolant to spray out, seriously scalding you. Always let the engine and radiator cool down before removing the radiator cap.

- If any coolant gets in your eyes, rinse them with water and consult a doctor immediately.
- If any coolant is swallowed, induce vomiting, gargle and consult a physician immediately.
- If any coolant gets on your skin or clothes, rinse thoroughly with plenty of water.

#### NOTICE

Using coolant with silicate corrosion inhibitors may cause premature wear of water pump seals or blockage of radiator passages. Using tap water may cause engine damage.

- Add coolant at the reserve tank. Do not remove the radiator cap except to refill or drain the system.
- All cooling system service can be done with the engine in the frame.
- Avoid spilling coolant on painted surfaces.
- After servicing the system, check for leaks with a cooling system tester.
- If any coolant gets in your eyes, rinse them with water and consult a doctor immediately.
- If any coolant is swallowed, induce vomiting, gargle and consult a doctor immediately.
- If any coolant get on your skin or clothes, rinse thoroughly with plenty of water.
- Refer to section 19 for coolant temperature indicator.

### SPECIFICATIONS

ITEM		SPECIFICATIONS
Coolant capacity	Radiator and engine	3.53 liters (3.73 US qt, 3.11 Imp qt)
	Reserve tank	0.65 liter (0.69 US qt, 0.57 Imp qt)
Radiator cap relief pressure		108 – 137 kPa (1.1 – 1.4 kgf/cm <sup>2</sup> , 16 – 20 psi)
Thermostat	Begin to open	76 – 80°C (169 – 176°F)
	Fully open	90°C (194°F)
	Valve lift	8 mm (0.3 in) minimum
Recommended antifreeze		Pro Honda HP Coolant or an equivalent high quality ethylene glycol antifreeze containing silicate-free corrosion inhibitors
Standard coolant concentration		1:1 mixture with distilled water

### TORQUE VALUES

Water pump cover sealing plate bolt	13 N·m (1.3 kgf·m, 9 lbf·ft)
Water pump cover bolt	13 N·m (1.3 kgf·m, 9 lbf·ft)
Radiator assembly mounting bolt	14 N·m (1.4 kgf·m, 10 lbf·ft)

## COOLING SYSTEM

---

### TROUBLESHOOTING

#### Engine temperature too high

- Faulty temperature gauge or ECT sensor
- Thermostat stuck closed
- Faulty radiator cap
- Insufficient coolant
- Passages blocked in radiator, hoses or water jacket
- Air in system
- Faulty cooling fan motor
- Faulty water pump

#### Engine temperature too low

- Faulty temperature gauge or ECT sensor
- Thermostat stuck open

#### Coolant leaks

- Faulty water pump mechanical seal
- Deteriorated O-rings
- Faulty radiator cap
- Damaged or deteriorated cylinder head gasket
- Loose hose connection or clamp
- Damaged or deteriorated hoses

# SYSTEM TESTING

## COOLANT (HYDROMETER TEST)

Remove the right fairing pocket (page 2-12).

Remove the radiator cap.



Test the coolant specific gravity using a hydrometer.

### STANDARD COOLANT CONCENTRATION: 50%

Look for contamination and replace the coolant if necessary.



### COOLANT GRAVITY CHART

		Coolant temperature °C (°F)										
		0 (32)	5 (41)	10 (50)	15 (59)	20 (68)	25 (77)	30 (86)	35 (95)	40 (104)	45 (113)	50 (122)
Coolant ratio %	5	1.009	1.009	1.008	1.008	1.007	1.006	1.005	1.003	1.001	0.999	0.997
	10	1.018	1.017	1.017	1.016	1.015	1.014	1.013	1.011	1.009	1.007	1.005
	15	1.028	1.027	1.026	1.025	1.024	1.022	1.020	1.018	1.016	1.014	1.012
	20	1.036	1.035	1.034	1.033	1.031	1.029	1.027	1.025	1.023	1.021	1.019
	25	1.045	1.044	1.043	1.042	1.040	1.038	1.036	1.034	1.031	1.028	1.025
	30	1.053	1.052	1.051	1.047	1.046	1.045	1.043	1.041	1.038	1.035	1.032
	35	1.063	1.062	1.060	1.058	1.056	1.054	1.052	1.049	1.046	1.043	1.040
	40	1.072	1.070	1.068	1.066	1.064	1.062	1.059	1.056	1.053	1.050	1.047
	45	1.080	1.078	1.076	1.074	1.072	1.069	1.066	1.063	1.060	1.057	1.054
	50	1.086	1.084	1.082	1.080	1.077	1.074	1.071	1.068	1.065	1.062	1.059
	55	1.095	1.093	1.091	1.088	1.085	1.082	1.079	1.076	1.073	1.070	1.067
	60	1.100	1.098	1.095	1.092	1.089	1.086	1.083	1.080	1.077	1.074	1.071

## COOLING SYSTEM

### RADIATOR CAP/SYSTEM PRESSURE INSPECTION

Remove the radiator cap.  
Wet the sealing surfaces of the cap, then install the cap onto tester.

Pressurize the radiator cap using the tester. Replace the radiator cap if it does not hold pressure, or if relief pressure is too high or too low. It must hold the specified pressure for at least 6 seconds.

**RADIATOR CAP RELIEF PRESSURE:**  
108 – 137 kPa (1.1 – 1.4 kgf/cm<sup>2</sup>, 16 – 20 psi)

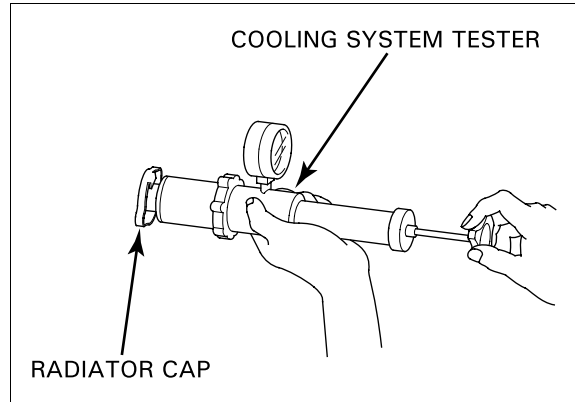

*Excessive pressure can damage the cooling system components. Do not exceed 137 kPa (1.4 kgf/cm<sup>2</sup>, 20 psi).*

Pressurize the radiator, engine and hoses using the tester, and check for leaks.

Repair or replace components if the system will not hold the specified pressure for at least 6 seconds.

Remove the tester and install the radiator cap.  
Install the right fairing pocket (page 2-12).



## COOLANT REPLACEMENT

### PREPARATION

#### NOTICE

*Using coolant with silicate corrosion inhibitors may cause premature wear of water pump seals or blockage of radiator passages. Using tap water may cause engine damage.*

#### NOTE:

- The effectiveness of coolant decreases with the accumulation of rust or if there is a change in the mixing proportion during usage. Therefore, for best performance change the coolant regularly as specified in the maintenance schedule.

Mix only distilled, low mineral water with the recommended antifreeze.

#### RECOMMENDED ANTIFREEZE:

**Pro Honda HP Coolant or an equivalent high quality ethylene glycol antifreeze containing silicate-free corrosion inhibitors**

#### RECOMMENDED MIXTURE:

**1:1 (distilled water and recommended antifreeze)**

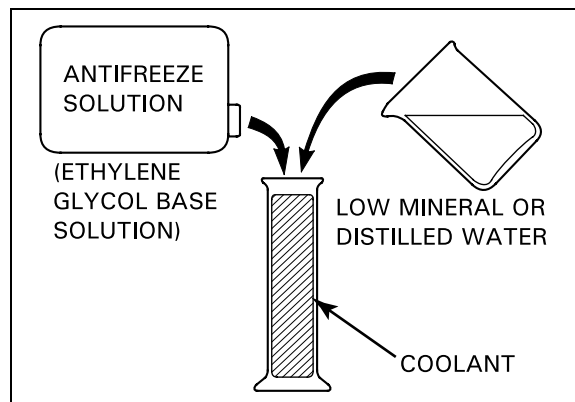

**REPLACEMENT/AIR BLEEDING**

**NOTE:**

- When filling the system or reserve tank with coolant, or checking the coolant level, place the motorcycle on its center stand on a flat, level surface.

Remove the following:

- left engine side cover (page 2-5)
- front lower fairing (page 2-6)
- radiator cap (page 6-6)



Drain the coolant from the system by removing the drain bolt and sealing washer.

Reinstall the drain bolt with a new sealing washer.



Remove the reserve tank mounting bolt and collar. Remove the reserve tank from the frame.

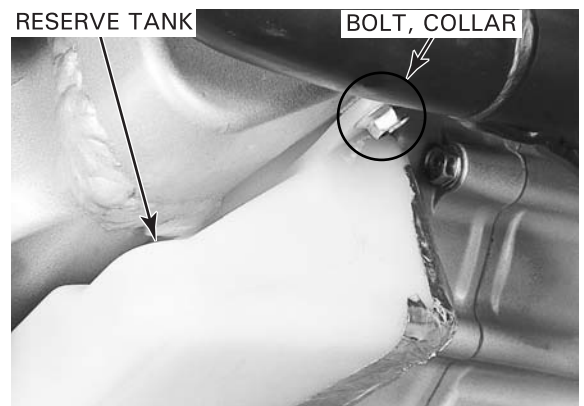

Disconnect the siphon hose and overflow hose from the reserve tank.

Empty the coolant and rinse the inside of the reserve tank with water.

Connect the siphon hose and overflow hose. Install the reserve tank by hooking the groove to the frame properly. Install the collar and mounting bolt.

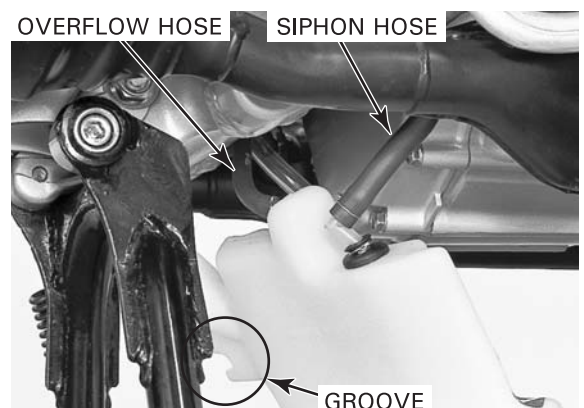

## COOLING SYSTEM

Fill the system with the recommended coolant through the filler opening up to the filler neck.

Install the radiator cap.

Bleed air from the system as follows:

1. Shift the transmission into neutral.  
Start the engine and let it idle for 2 – 3 minutes.
2. Snap the throttle three to four times to bleed air from the system.
3. Stop the engine and add coolant up to the filler neck.
4. Install the radiator cap.



Remove the reserve tank cap/dipstick.

Fill the reserve tank to the upper level hole of the dipstick with the motorcycle on its center stand on a flat, level surface.

Install the following:

- left engine side cover (page 2-5)
- front lower fairing (page 2-6)
- right fairing pocket (page 2-12)

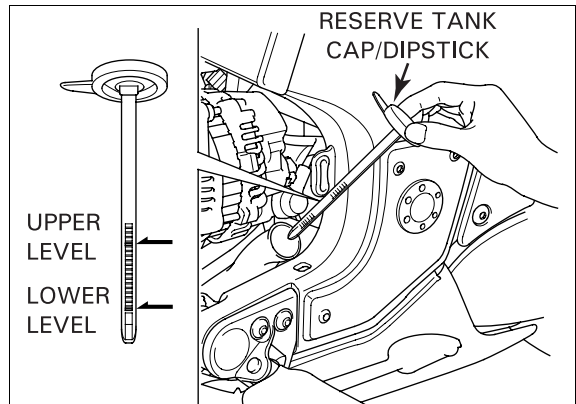

## RADIATOR/COOLING FAN

### REMOVAL

Drain the coolant from the system (page 6-6).

Remove the front fairing (page 2-10).

Remove the top shelter (page 2-11).

### RIGHT RADIATOR

*Be careful not to damage the radiator fins while servicing the radiator.*

Disconnect the right radiator fan motor 2P (white) connector.

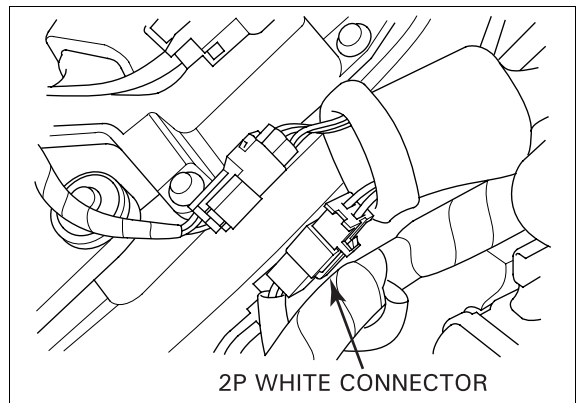



Remove the two screws attaching the connector holder to the air duct.

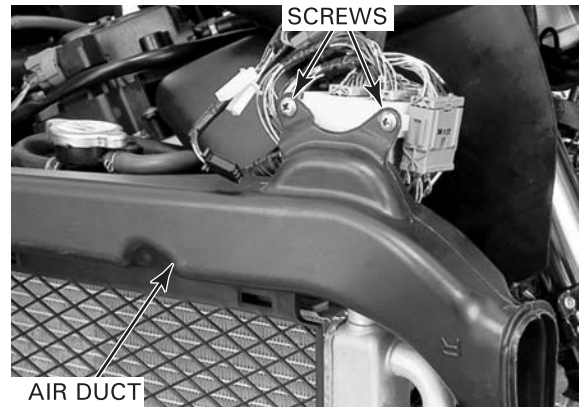

Remove the three trim clips and air duct.

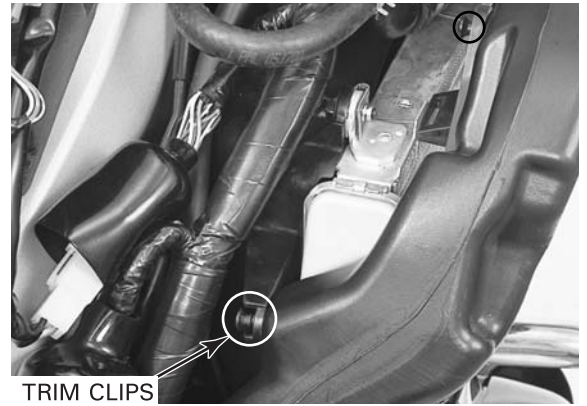

Remove the radiator grille from the radiator by releasing the four hooks from the tabs.



Disconnect the siphon hose.  
Loosen the band screws and disconnect the radiator hose and bleed hose.  
Loosen the bolt and remove the filler neck from the radiator shroud.

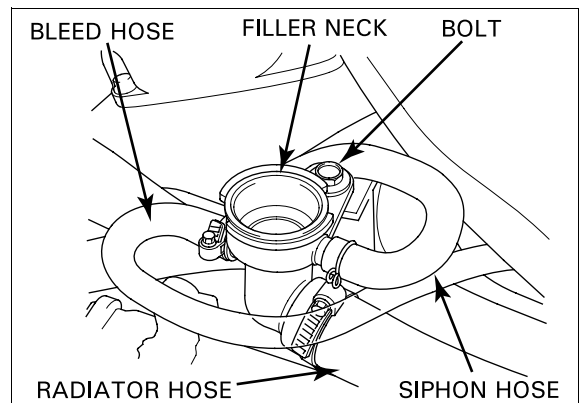



## COOLING SYSTEM

Loosen the band screws and disconnect the drain hose, upper and lower radiator hoses.

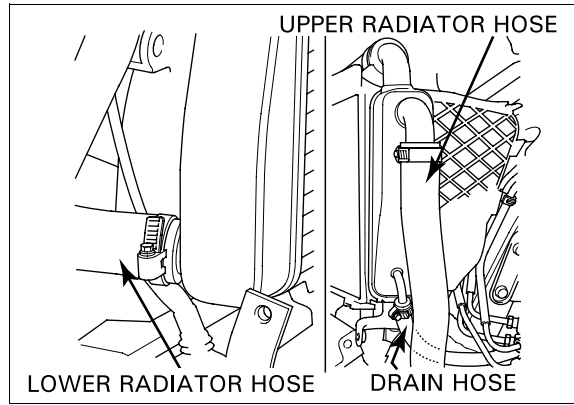

Remove the two mounting bolts and the right radiator assembly.

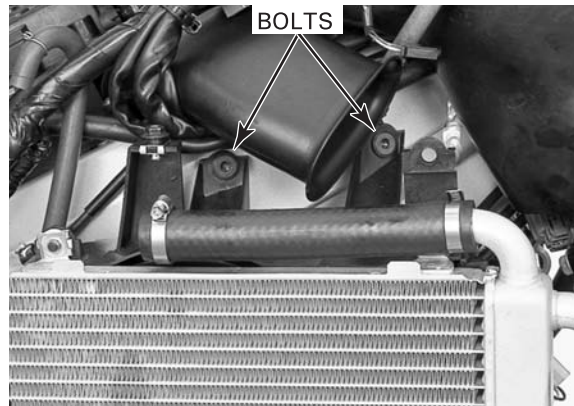

### LEFT RADIATOR

*Be careful not to damage the radiator fins while servicing the radiator.*

Disconnect the left radiator fan motor 2P black connector.



Remove the two screws attaching the connector holder to the air duct.

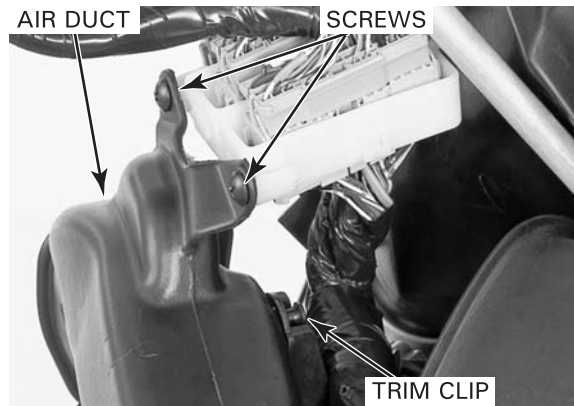

Remove the three trim clips and air duct.

Remove the radiator grille from the radiator by releasing the four hooks from the tabs.

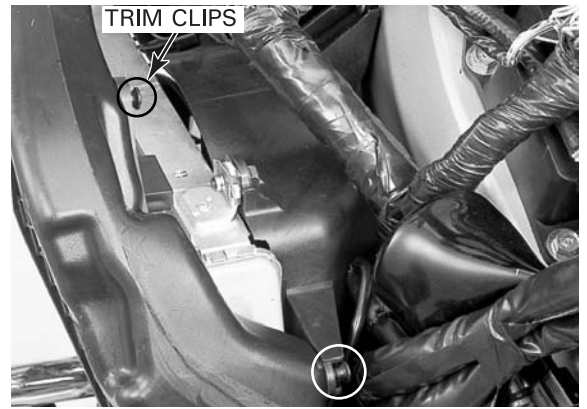

Loosen the band screws and disconnect the bleed hose, drain hose, upper and lower radiator hoses.

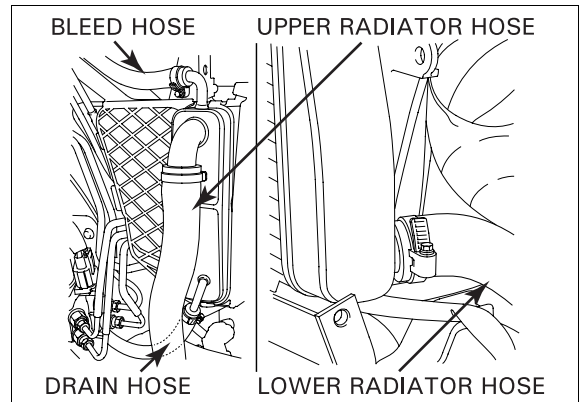

Remove the two mounting bolts and the left radiator assembly.

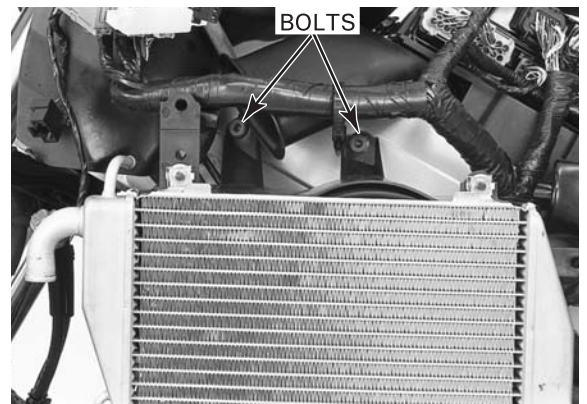

### DISASSEMBLY

Remove the three bolts, condenser and the fan shroud/motor assembly from the radiator.

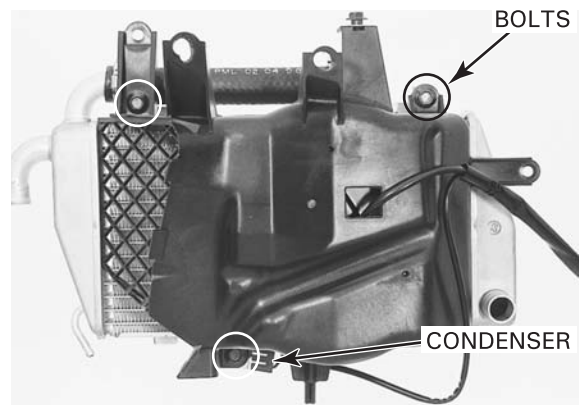

## COOLING SYSTEM

Remove the nut and cooling fan from the fan motor.

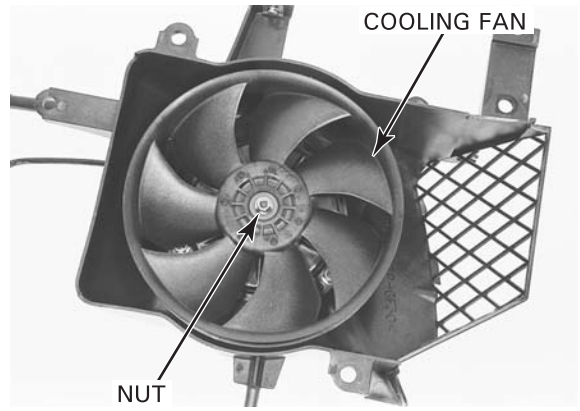

Remove the three bolts and fan motor from the shroud.

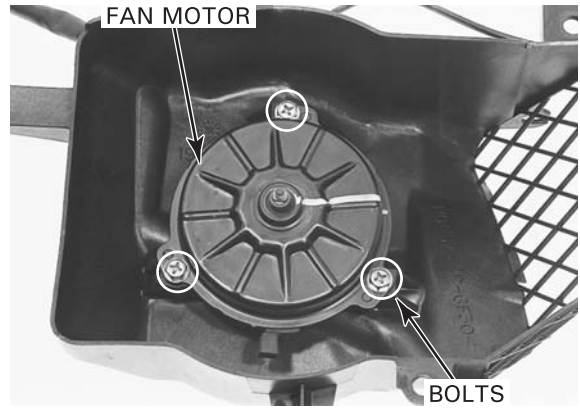

## ASSEMBLY

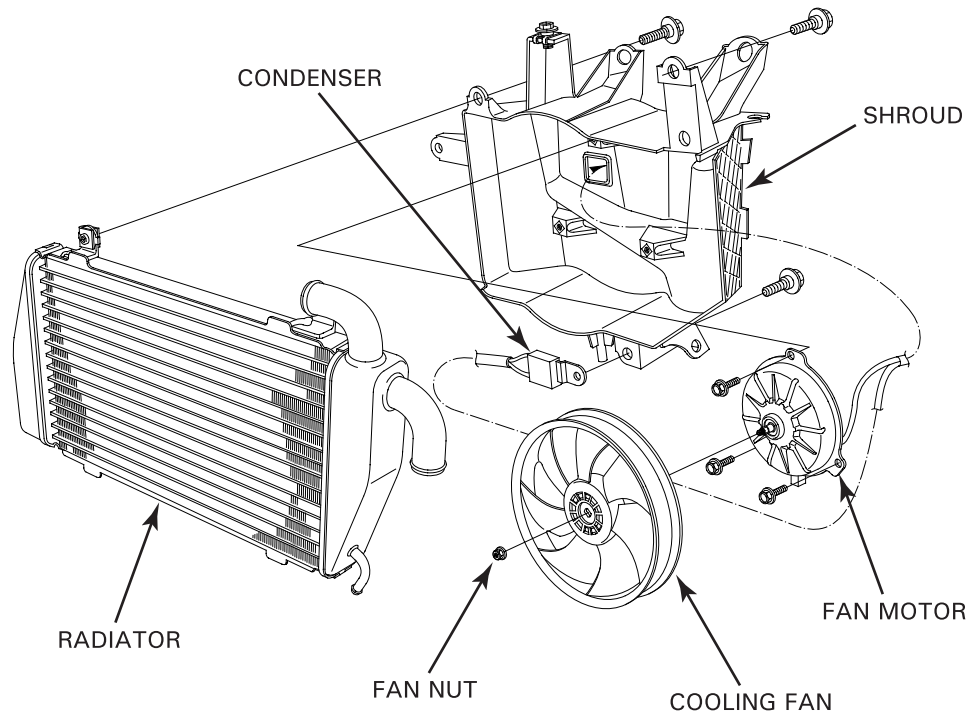

Route the fan motor wire and condenser wire through the shroud. Install the fan motor onto the shroud with the drain hose facing down as shown, then install the three bolts and tighten them securely.

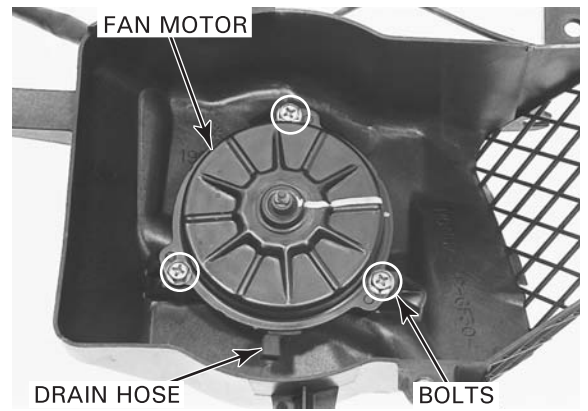

Install the cooling fan onto the motor shaft, aligning the flat surfaces. Apply locking agent to the fan nut threads. Install the nut and tighten it securely.

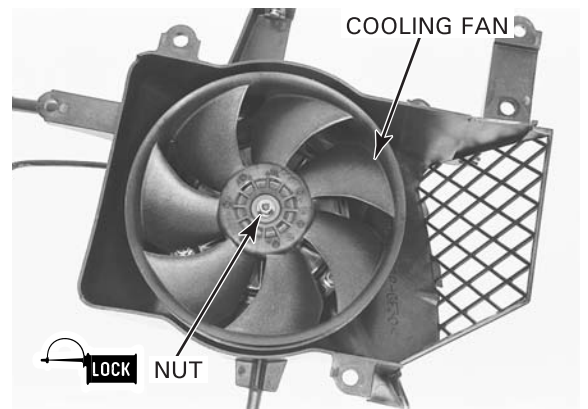

Install the fan shroud/motor assembly and condenser, and tighten the three bolts securely.

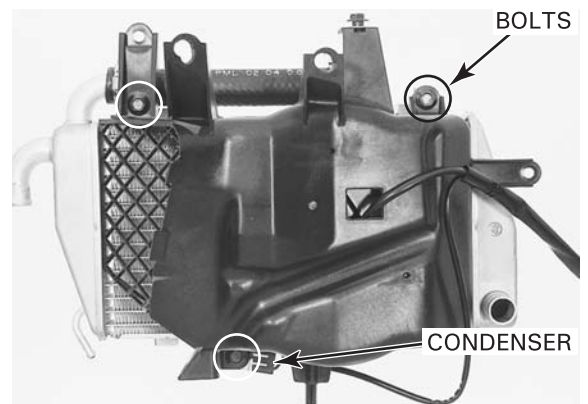

## **INSTALLATION**

### **RIGHT RADIATOR**

Install the right radiator by inserting the boss into the grommet in the stay.

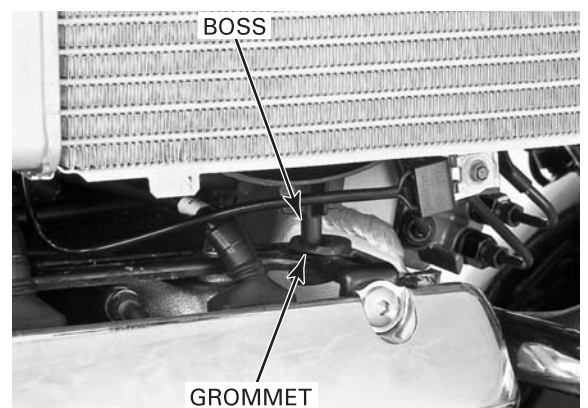



## COOLING SYSTEM

Install the two mounting bolts and tighten them.

**TORQUE: 14 N·m (1.4 kgf·m, 10 lbf·ft)**

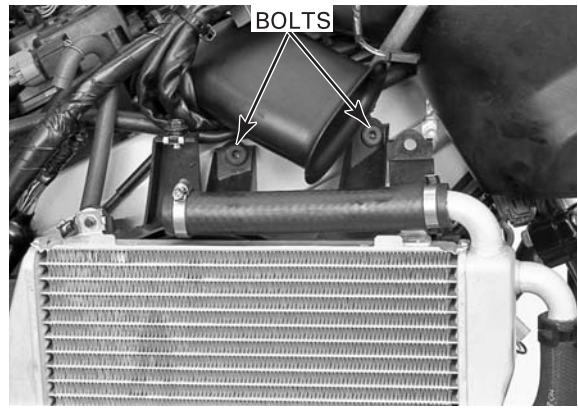

Connect the drain hose, upper and lower radiator hoses and tighten the band screws securely.

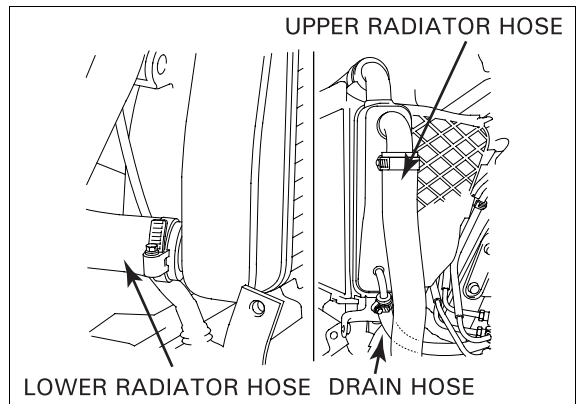

Install the filler neck onto the shroud and tighten the bolt securely.

Connect the radiator hose and bleed hose and tighten the band screws securely.  
Connect the siphon hose and secure it with the clip.

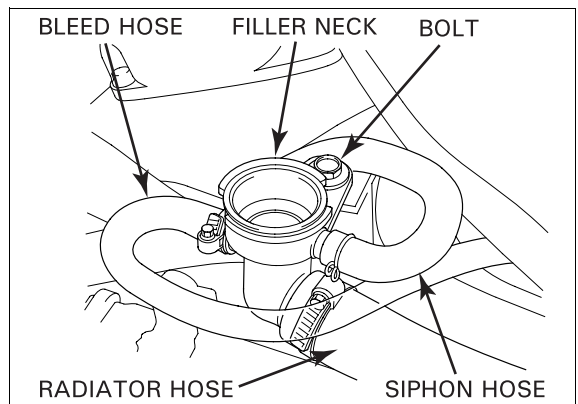

Install the right radiator grille onto the radiator.

**NOTE:**

- The right radiator grille has an "R" mark.



Install the right air duct and secure it with the three trim clips.

**NOTE:**

- The right air duct has an "R" mark.

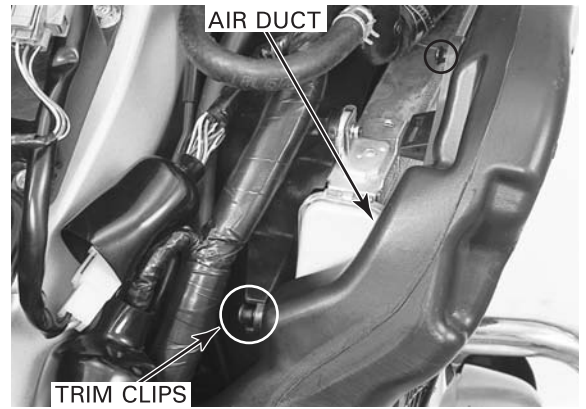

Install the connector holder onto the air duct and tighten the screws securely.



Connect the right fan motor 2P white connector.

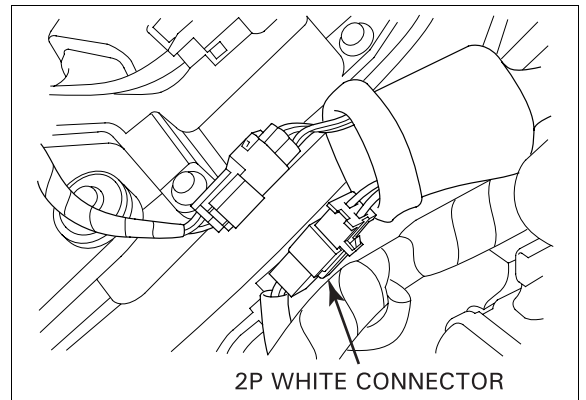

### LEFT RADIATOR

Install the left radiator by inserting the boss into the grommet in the stay.

Install the two mounting bolts and tighten them.

**TORQUE: 14 N-m (1.4 kgf-m, 10 lbf-ft)**

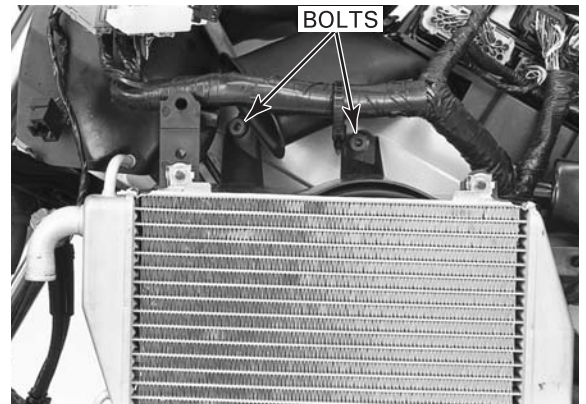

## COOLING SYSTEM

Connect the bleed hose, drain hose, upper and lower radiator hoses, and tighten the band screws securely.

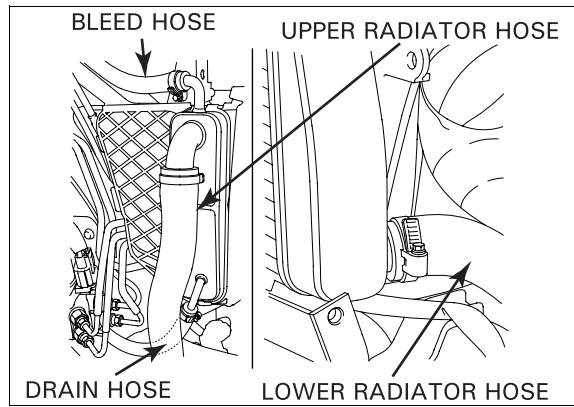

Install the left radiator grille onto the radiator.

NOTE:

- The left radiator grille has an "L" mark.

Install the left air duct and secure it with the three trim clips.

NOTE:

- The left air duct has an "L" mark.

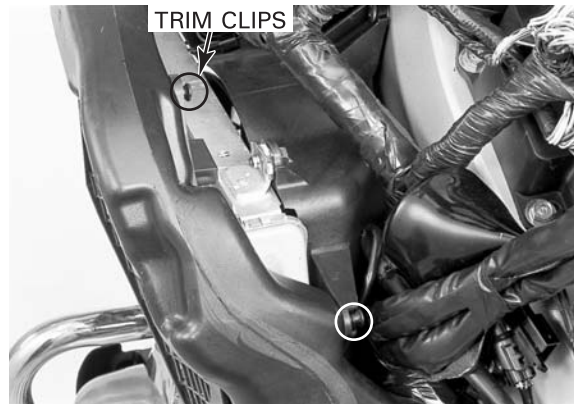

Install the connector holder onto the air duct and tighten the screws securely.

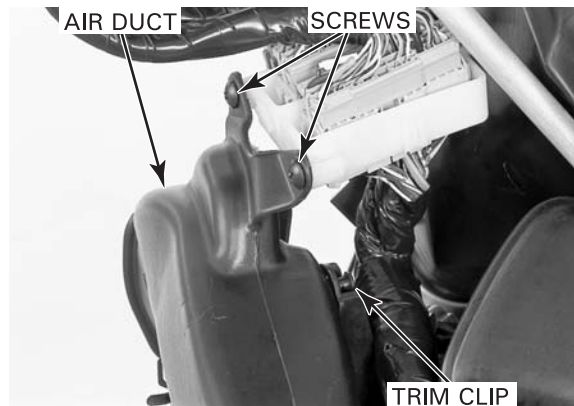

Connect the left fan motor 2P black connector.

Install the top shelter (page 2-11).

Install the front fairing (page 2-10).

Fill and bleed the cooling system (page 6-6).



## WATER PUMP/THERMOSTAT

### MECHANICAL SEAL INSPECTION

Remove the radiator reserve tank (page 6-8).

Check for signs of coolant leakage from the inspection hole in the water pump by looking the clutch cover.

If there is leakage, the water pump mechanical seal is defective and the water pump should be replaced.

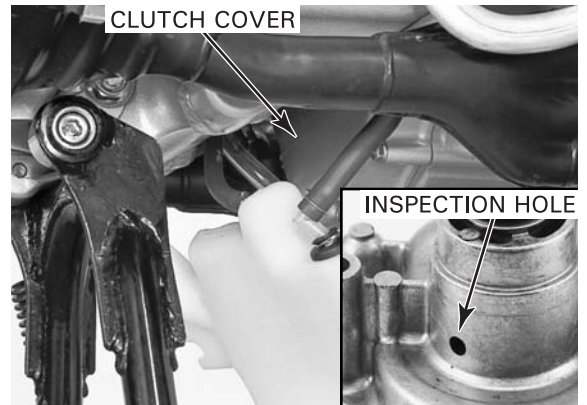

### REMOVAL

*The water pump and thermostat can be removed with the engine in the frame.*

Drain the coolant from the system (page 6-7).  
Remove the starter/reverse motor (page 19-17).  
Remove the alternator (page 17-10).

Loosen the hose band screws and disconnect the three water hoses from the water pump.

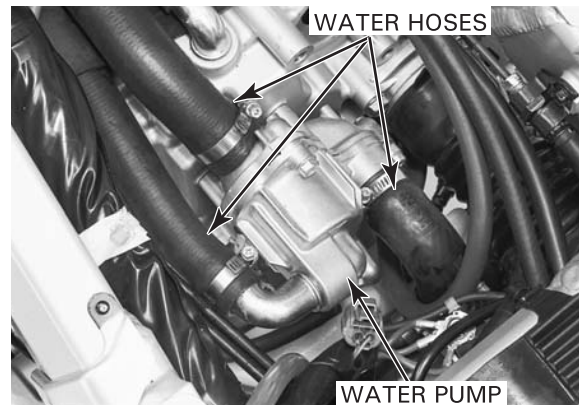

Remove the three pump cover bolts and three water pump mounting bolts.

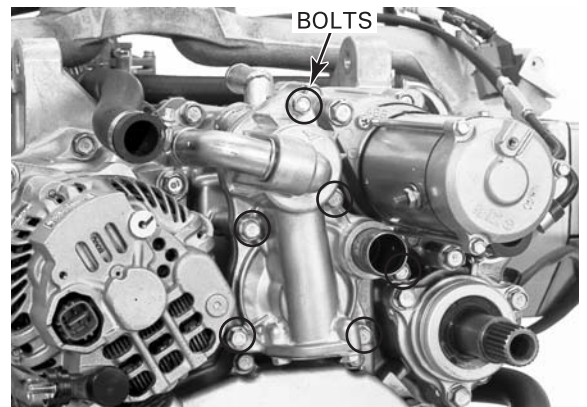

Remove the water pump cover.  
Remove the thermostat from the pump cover.  
Remove the rubber seal from the thermostat.  
Remove the O-ring from the water pump.

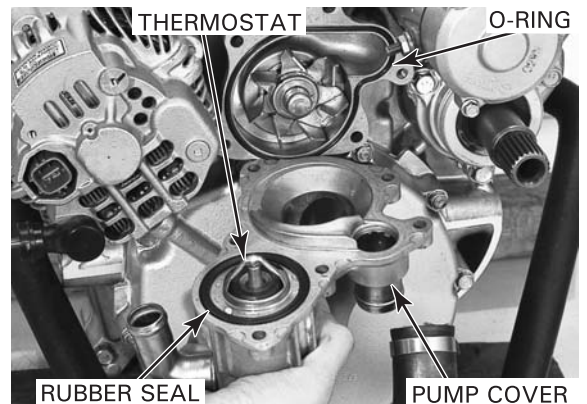



## COOLING SYSTEM

Remove the water pump from the rear crankcase cover.  
Remove the O-ring from the water pump.

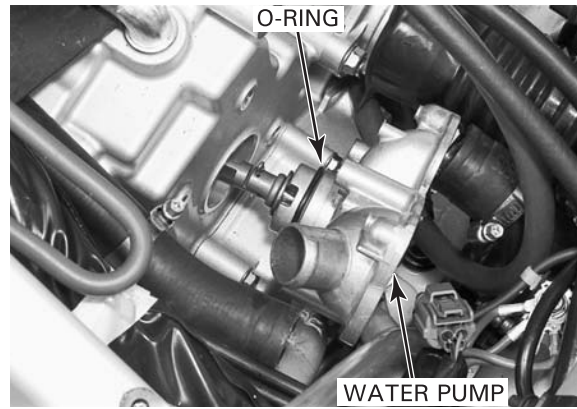

Remove the lock pin and water pump shaft joint from the pump shaft if necessary.

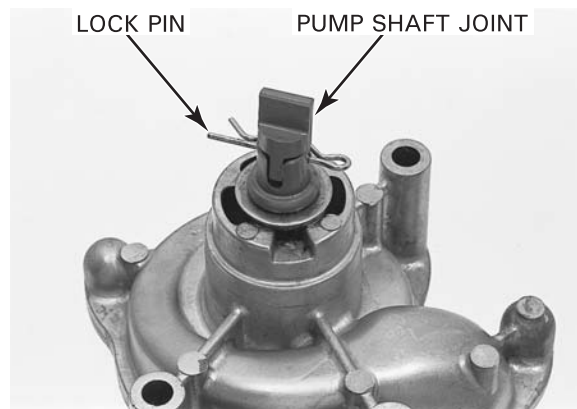

### THERMOSTAT INSPECTION

Visually inspect the thermostat for damage.  
Replace the thermostat if the valve stays open at room temperature.

*Wear insulated gloves and adequate eye protection. Keep flammable materials away from the electric heating element. Do not let the thermostat or thermometer touch the pan, or you will get false readings.*

Heat a container of water with an electric heating element for 5 minutes.  
Suspend the thermostat in the heated water to check its operation.

**THERMOSTAT BEGINS TO OPEN:**  
**76 – 80° C (169 – 176° F)**

**VALVE LIFT:**  
**8 mm (0.3 in) minimum at 90° C (194° F)**

Replace the thermostat if the valve opens at a temperature other than those specified.

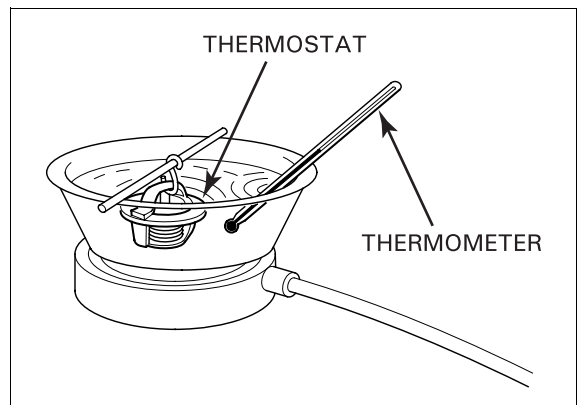

### INSTALLATION

Install the pump shaft joint and secure it with a new lock pin.

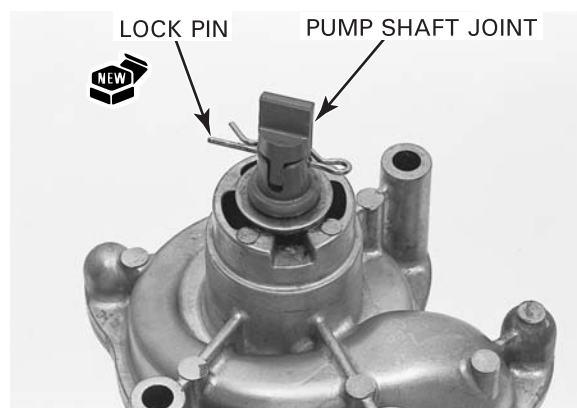

Coat a new O-ring with engine oil and install it into the groove in the water pump. Install the water pump into the rear crankcase cover while aligning the flat end of the pump shaft joint with the slot in the starter clutch bolt.



Install a new O-ring onto the water pump groove.

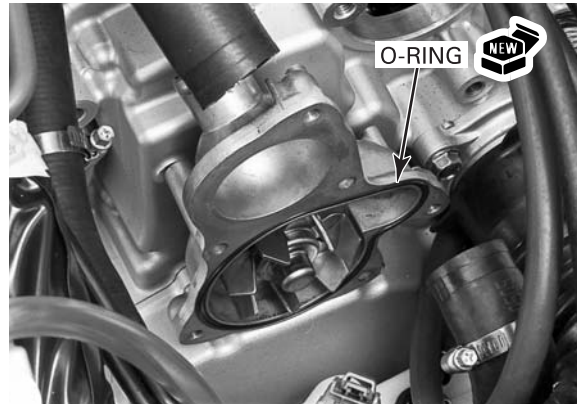

Install a new rubber seal onto the thermostat flange. Install the thermostat into the water pump cover with the hole facing upward while aligning the lug with the cover groove as shown.

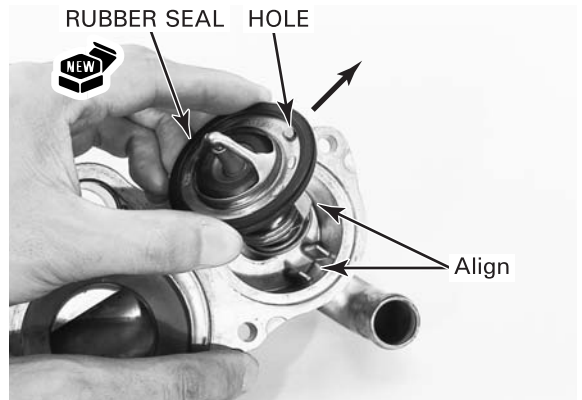

Install the water pump cover onto the pump. Install the three cover bolts and three mounting bolts, and tighten them.

**TORQUE: Cover bolt: 13 N·m (1.3 kgf·m, 9 lbf·ft)**

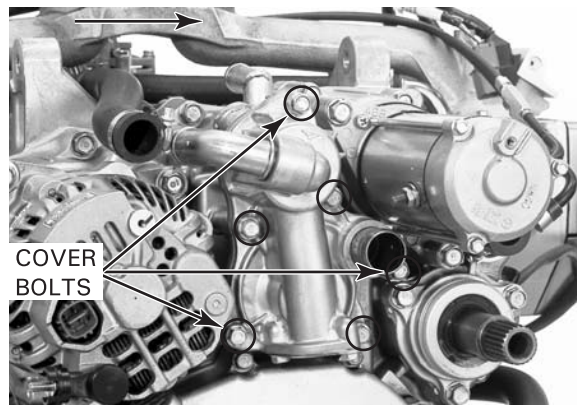

## COOLING SYSTEM

---

Connect the water hoses to the water pump and tighten the hose band screws securely.

Install the alternator (page 17-18).

Install the starter/reverse motor (page 19-23).

Fill and bleed the cooling system (page 6-6).

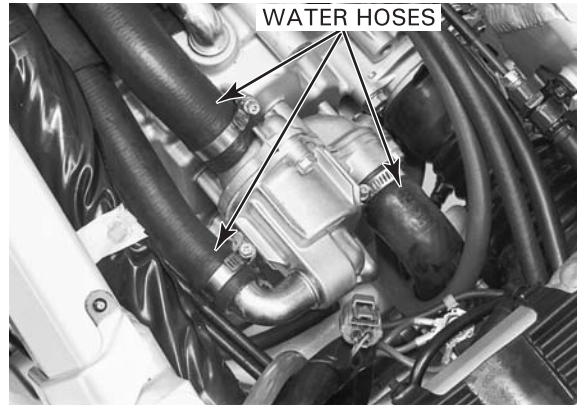

# 7. ENGINE REMOVAL/INSTALLATION

---

COMPONENT LOCATION .....	7-2	ENGINE REMOVAL .....	7-5
SERVICE INFORMATION .....	7-3	ENGINE INSTALLATION .....	7-11

# ENGINE REMOVAL/INSTALLATION

## COMPONENT LOCATION

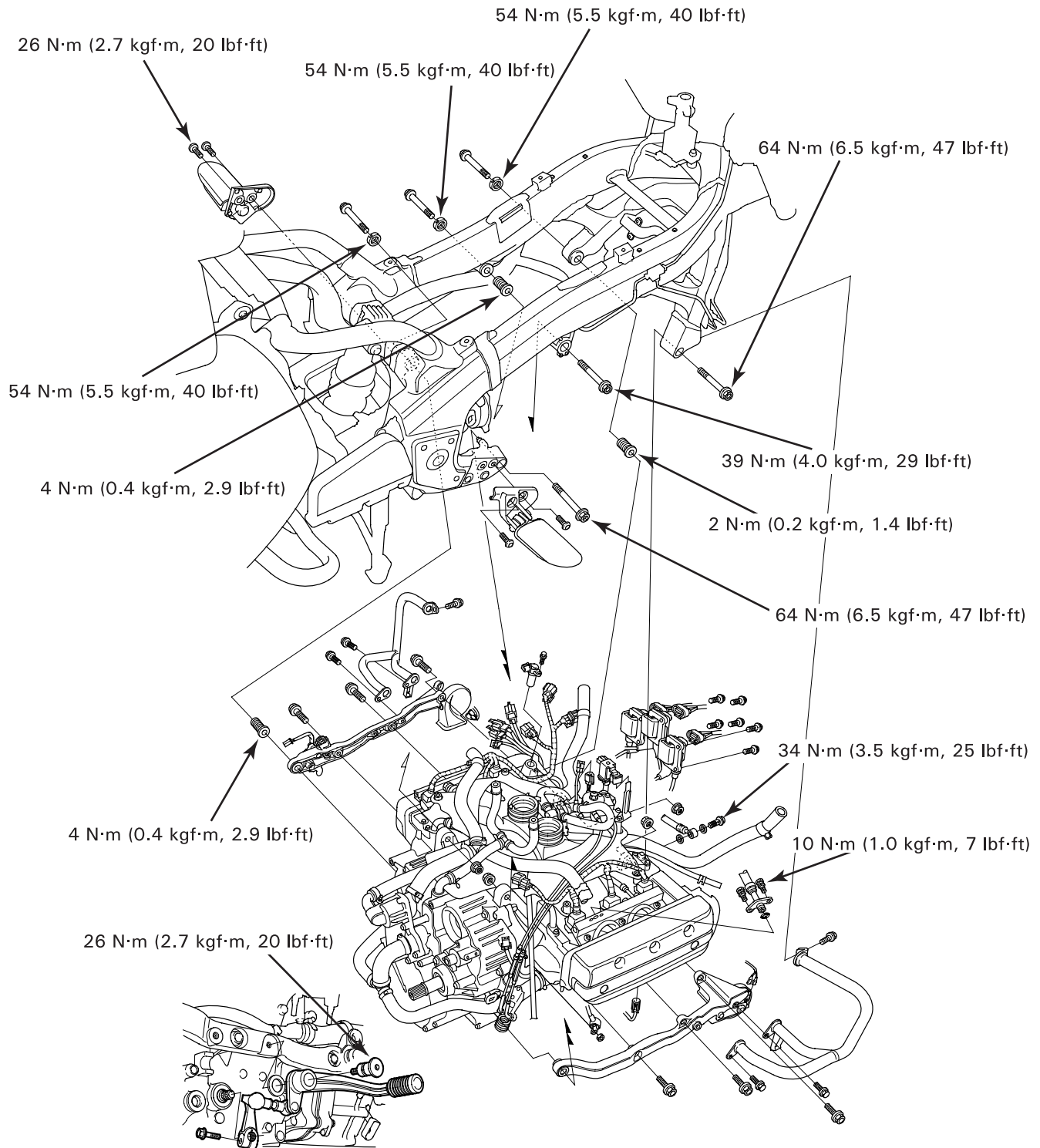

**SERVICE INFORMATION**

**GENERAL**

- A floor jack or other adjustable support is required to support and maneuver the engine.
- A hoist or equivalent is required to support the motorcycle when removing and installing the engine.

**NOTICE**

*Supporting the engine using the engine oil filter will damage the engine.*

- When removing/installing the engine, tape the frame around the engine beforehand for frame protection.
- The following components require engine removal for servicing.
  - oil pump (section 4)
  - intake manifold (section 5)
  - primary gears/output shaft (section 10)
  - piston/connecting rod (section 11)
  - crankcase, crankshaft (section 11)
  - transmission (including gearshift spindle: section 11)
  - reverse shifter/shift drum lock arm (section 18)
- The following components can be serviced with the engine in the frame.
  - throttle body, injector (section 5)
  - water pump/thermostat (section 6)
  - cylinder head/valves (section 8)
  - clutch (section 9)
  - gearshift linkage (exception of the gearshift spindle: section 10)
  - alternator (section 16)
  - ignition pulse generator (section 17)
  - starter/reverse motor (section 18)
- When using the lock nut wrench, use a deflecting beam type torque wrench 20-inches long. The lock nut wrench increases the torque wrench’s leverage, so the torque wrench reading will be less than the torque actually applied to the lock nut. The specification given on the next page is the actual torque applied to the lock nut, not the reading on the torque wrench when used with the lock nut wrench. The procedure later in the text gives both actual and indicated torque readings.

**SPECIFICATIONS**

ITEM	SPECIFICATIONS
Engine dry weight	118.3 kg (260.8 lbs)
Engine oil capacity at disassembly	4.6 liters (4.9 US qt, 4.0 Imp qt)
Coolant capacity (radiator and engine)	3.53 liters (3.73 US qt, 3.11 Imp qt)

**TORQUE VALUES**

Engine hanger bolt	(front/rear)	64 N·m (6.5 kgf·m, 47 lbf·ft)
	(center)	39 N·m (4.0 kgf·m, 29 lbf·ft)
Left engine hanger adjusting bolt	(front)	2 N·m (0.2 kgf·m, 1.4 lbf·ft)
	(center)	4 N·m (0.4 kgf·m, 2.9 lbf·ft)
	(rear)	4 N·m (0.4 kgf·m, 2.9 lbf·ft)
Left engine hanger adjusting bolt lock nut	(front/rear)	54 N·m (5.5 kgf·m, 40 lbf·ft)
	(center)	54 N·m (5.5 kgf·m, 40 lbf·ft)
Driver footpeg mounting bolt		26 N·m (2.7 kgf·m, 20 lbf·ft)
Gearshift pedal pivot bolt		26 N·m (2.7 kgf·m, 20 lbf·ft)
Fuel feed hose joint bolt		10 N·m (1.0 kgf·m, 7 lbf·ft)
Clutch hose oil bolt		34 N·m (3.5 kgf·m, 25 lbf·ft)
Engine oil drain bolt		34 N·m (3.5 kgf·m, 25 lbf·ft)

## ENGINE REMOVAL/INSTALLATION

---

### TOOLS

Lock nut wrench  
07908-ME90000

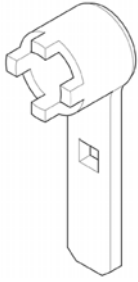

or 07GMA-KT7A200 (U.S.A. only)

Lock nut wrench, 20 mm  
07VMA-MBB0101

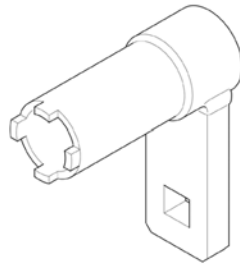



## ENGINE REMOVAL

Support the motorcycle securely on its center stand.

Drain the engine oil before removing the engine if the clutch cover gearshift linkage cover and engine rear cover are to be removed (page 3-12).

Remove the following:

- front fender B (page 13-24)
- both side covers (page 2-5)
- both engine side covers (page 2-5)
- center inner fairing (page 2-10)
- muffler system (page 2-18)
- radiator reserve tank (page 6-8)
- throttle body (page 5-58)
- both injector covers and radiator stay (page 5-61)

### NOTE:

- Wrap the intake ports with a shop towel or cover them with a piece of tape to prevent any foreign material from dropping into the engine.

Disconnect the ignition pulse generator 2P red connector.

Disconnect the reverse shift actuator 3P red and 2P white connectors.

Disconnect the gear position switch 6P black connector.



Disconnect the left engine sub-wire harness 4P gray and 6P gray connectors.

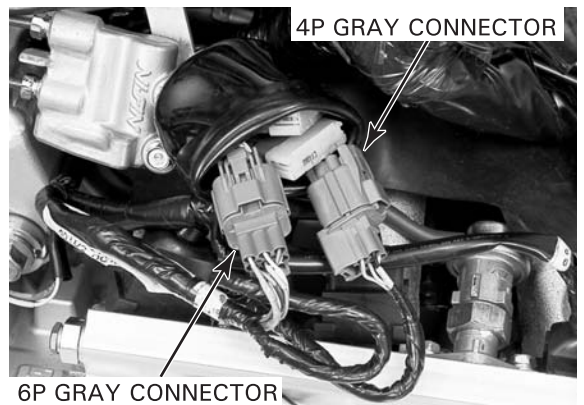

Disconnect the right engine sub-wire harness 8P gray, 4P gray and speed sensor 3P white connectors.

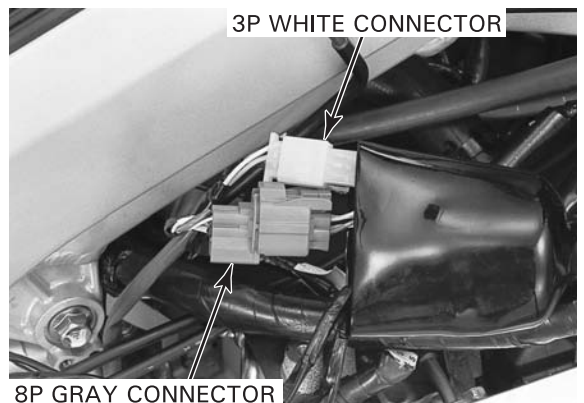

## ENGINE REMOVAL/INSTALLATION

Remove the bolt and rear brake reservoir stay.

Slide the rubber cap off the reverse switch terminal, and remove the nut and reverse switch wire.

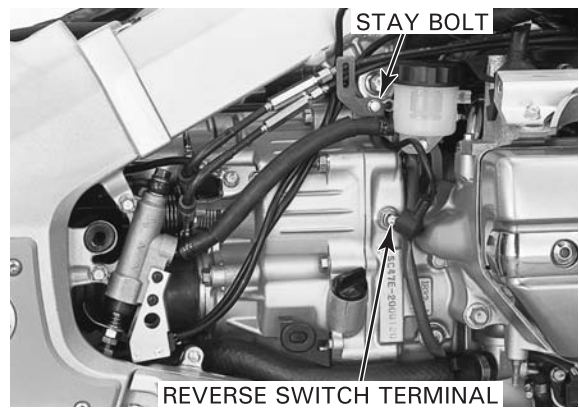

Slide the rubber cap off the starter motor terminal, and remove the terminal nut and starter/reverse motor cable.

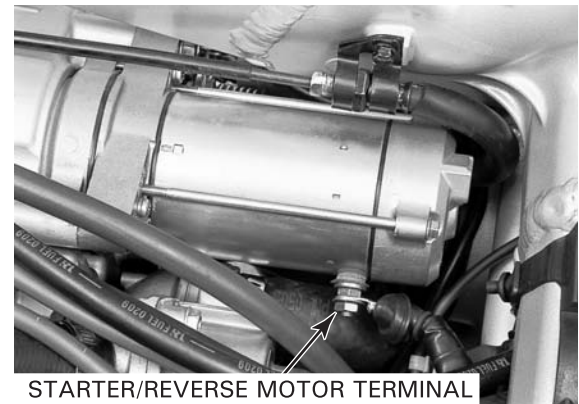

Disconnect the side stand switch 3P green connector and remove the wire band.

Slide the rubber cap off the alternator terminal, and remove the terminal nut and alternator cable. Disconnect the alternator 4P connector.

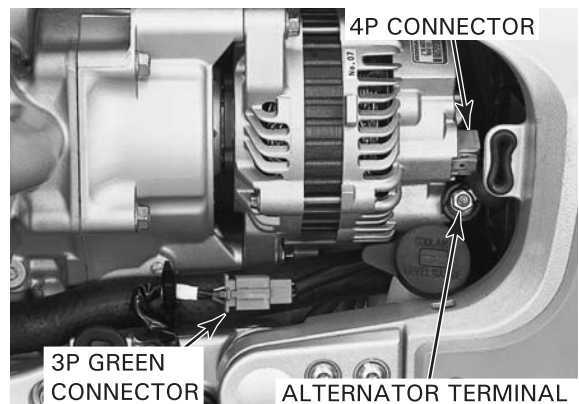

Disconnect the evaporative emission (EVAP) purge control solenoid valve connector.

Remove the EVAP purge control solenoid valve from the stay.

Remove the spark plug wires from the ignition coils. Remove the wire clamp from the stay and remove it from the No. 2 and No. 5 spark plug wires.

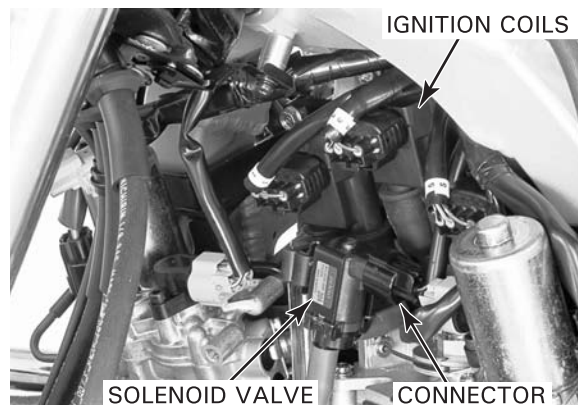

## ENGINE REMOVAL/INSTALLATION

Disconnect the connectors from both knock sensors.  
Disconnect connectors from both horns.

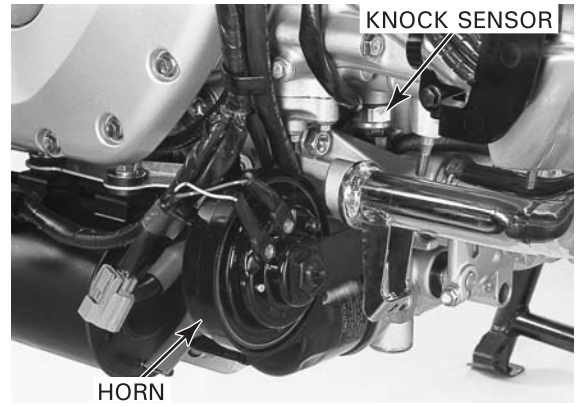

Disconnect the No. 1 and No. 4 hoses from the EVAP canister.  
Remove the wire band.  
Remove the two bolts, EVAP canister bracket and coolant drain joint from the engine.

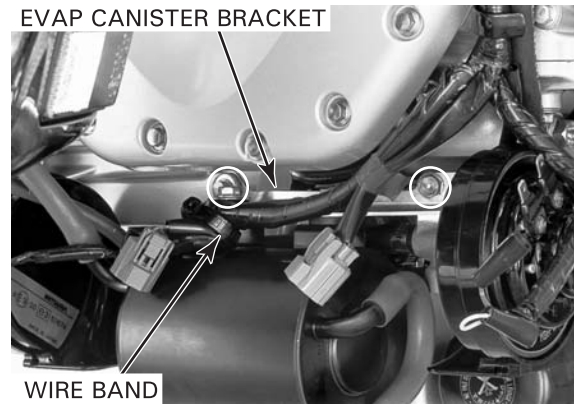

Drain the clutch fluid from the hydraulic system (page 9-7).

Remove the clutch slave cylinder oil bolt and sealing washers.

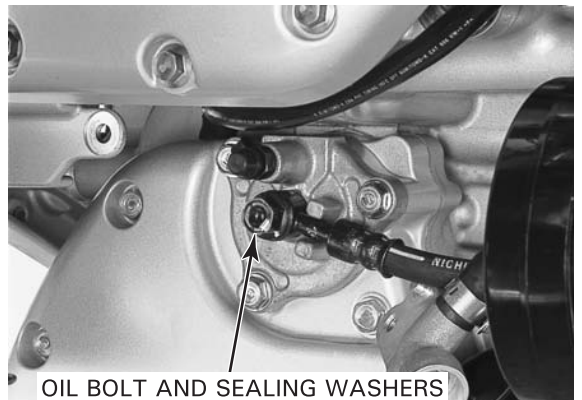

Remove the gearshift pedal pivot bolt and washer.  
Remove the pinch bolt and gearshift pedal/arm from the gearshift spindle.

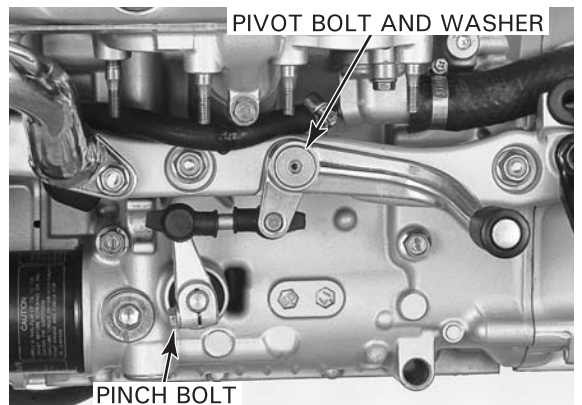



## ENGINE REMOVAL/INSTALLATION

Remove the mounting bolts and both engine guards.

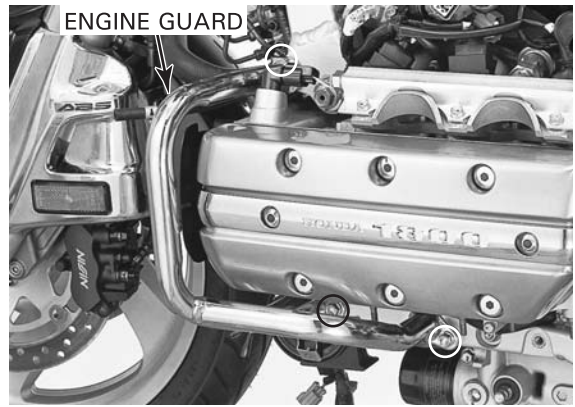

Remove the mounting bolts and both driver footpegs.

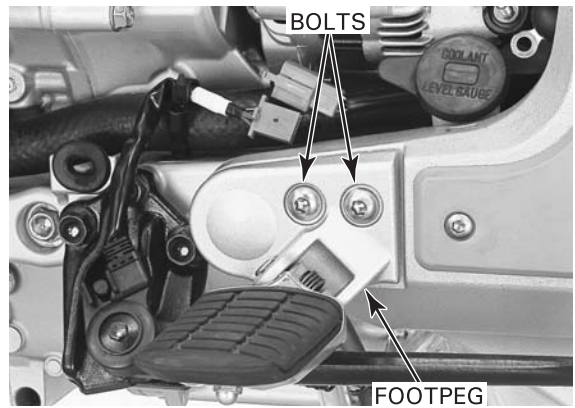

Remove the two bolts and fuel feed hose joint from the right fuel rail.

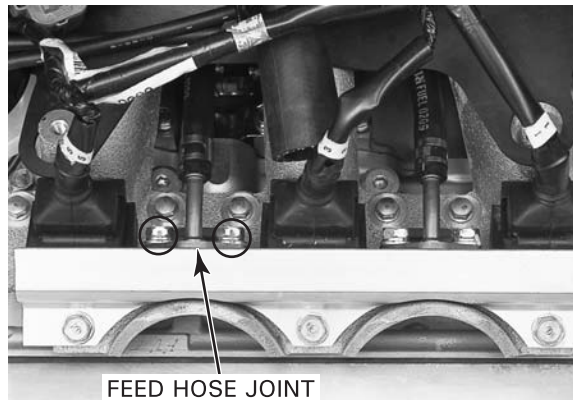

Place a floor jack or other adjustable support under the engine.

**NOTE:**

- The jack height must be continually adjusted to relieve stress for ease of bolt removal.

Loosen the three left sub-frame mounting bolts.

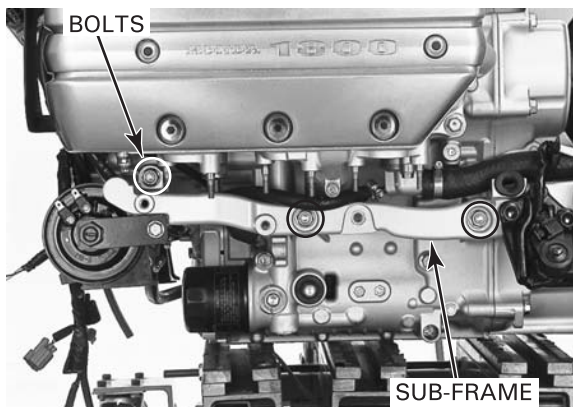

## ENGINE REMOVAL/INSTALLATION

Loosen the three right sub-frame mounting bolts.

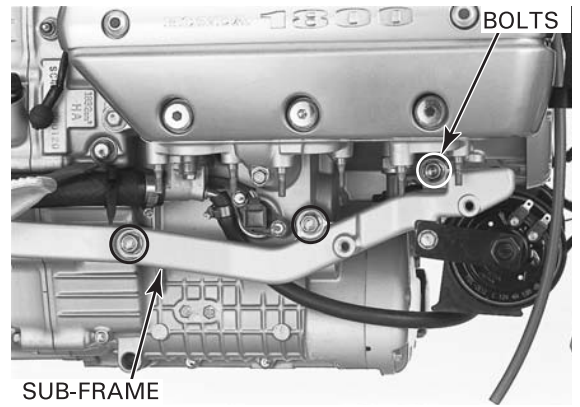

Remove the left center engine hanger bolt and nut.  
Remove the left front engine hanger bolt and nut.

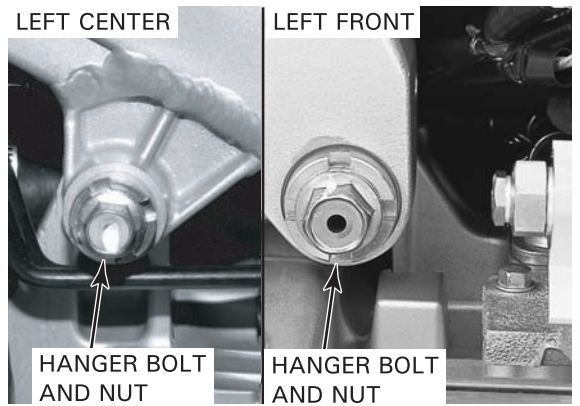

Remove the left rear engine hanger bolt.

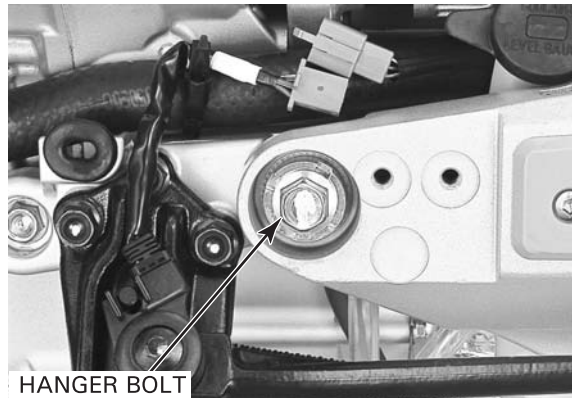

Loosen the left center engine hanger adjusting bolt lock nut using the special tool.

**TOOL:**  
**Lock nut wrench, 20 mm**      **07VMA-MBB0101**

Remove the lock nut.  
Loosen the left center engine hanger adjusting bolt.

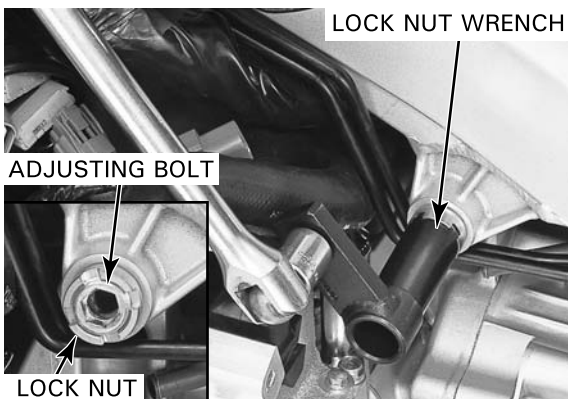

## ENGINE REMOVAL/INSTALLATION

Loosen the left front engine hanger adjusting bolt lock nut using the special tool.

**TOOL:**

**Lock nut wrench**                      **07908-ME90000 or  
07GMA-KT7A200  
(U.S.A. only)**

Remove the lock nut.  
Loosen the left front engine hanger adjusting bolt.

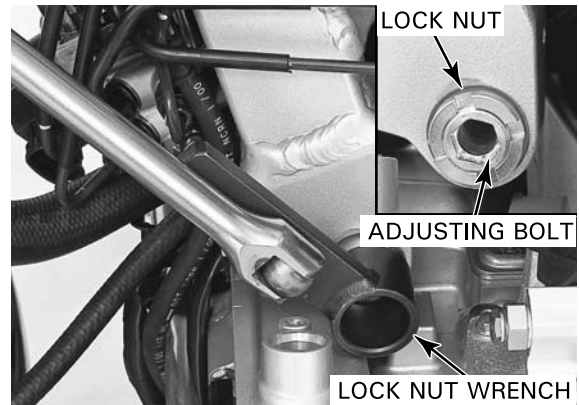

Loosen the left rear engine hanger adjusting bolt lock nut using the special tool.

**TOOL:**

**Lock nut wrench**                      **07908-ME90000 or  
07GMA-KT7A200  
(U.S.A. only)**

Remove the lock nut.  
Loosen the left rear engine hanger adjusting bolt.  
Remove the three bolts and left sub-frame.

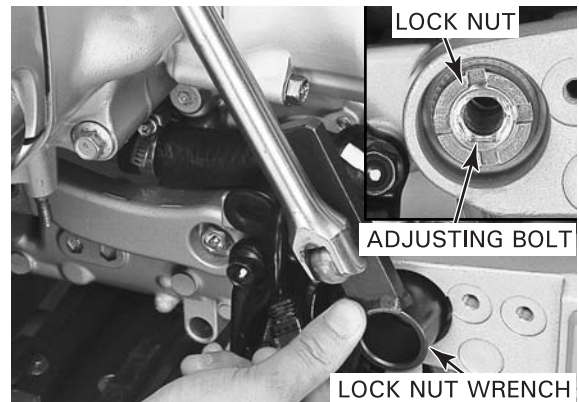

Remove the right center engine hanger bolt and nut.

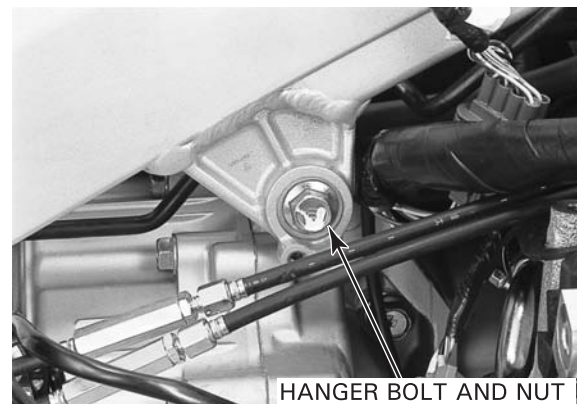

Remove the right front engine hanger bolt and nut.

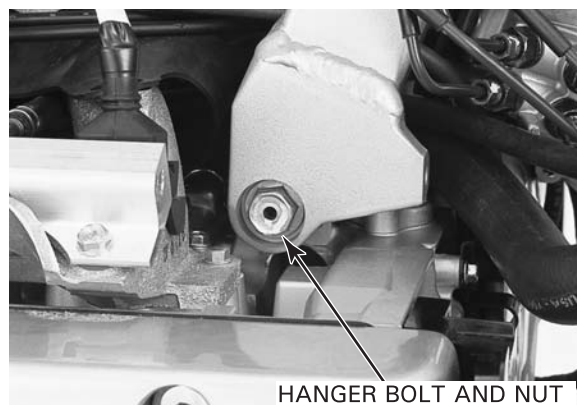

Remove the right rear engine hanger bolt.  
Remove the three bolts and right sub-frame.

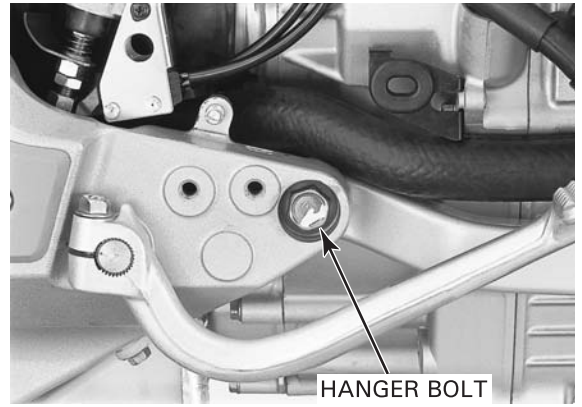

**NOTE:**

- A hoist or equivalent is required to support the motorcycle when removing the engine.
- Remove the joint boot from the engine side.  
Move the engine forward slightly and remove the output shaft from the universal joint.  
Lower the engine and move it out of the frame.

*Be careful not to damage the wire harnesses, hoses, and cables during engine removal.*

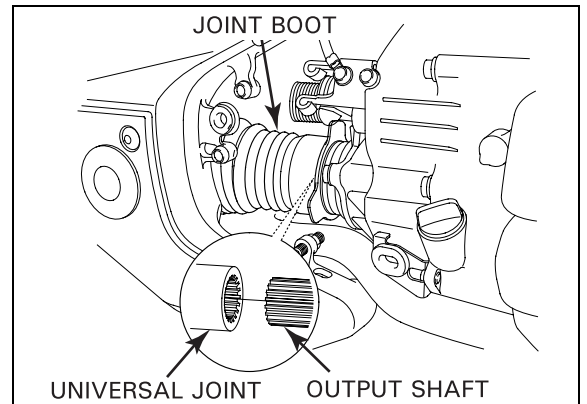

## ENGINE INSTALLATION

**NOTE:**

- Before installing the engine, route the wires, hoses, and cables properly (page 1-23).
- When tightening the lock nut with the lock nut wrench, refer to torque wrench reading information on page 7-3 "SERVICE INFORMATION."
- A hoist or equivalent is required to support the motorcycle when installing the engine.
- Be sure to use the engine hanger adjusting bolts, adjusting bolt lock nuts, hanger bolts and hanger nuts in their correct positions.

Install the engine hanger adjusting bolts into the left side mounting points from the inside, and screw them in fully.

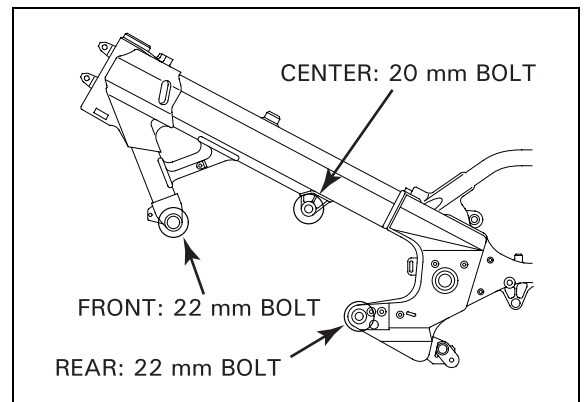



## ENGINE REMOVAL/INSTALLATION

Use a floor jack or other adjustable support to carefully maneuver the engine into place.

Apply 1 g (0.04 oz) of molybdenum disulfide grease to the output shaft splines.

*Be careful not to damage the wire harnesses, hoses, and cables during engine installation.*

Install the engine in the frame while engaging the universal joint splines with the output shaft splines. Install the joint boot over the output gear case securely.

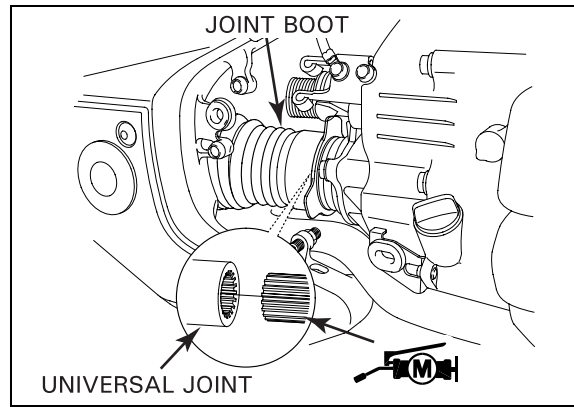

Temporarily install the sub-frames, front and rear engine hanger bolts and nuts, then tighten the engine mounting fasteners to the specified torque in the correct sequence.

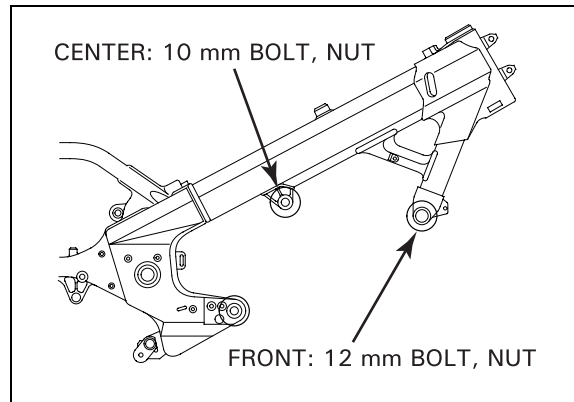

1. Tighten the right sub-frame mounting bolts.

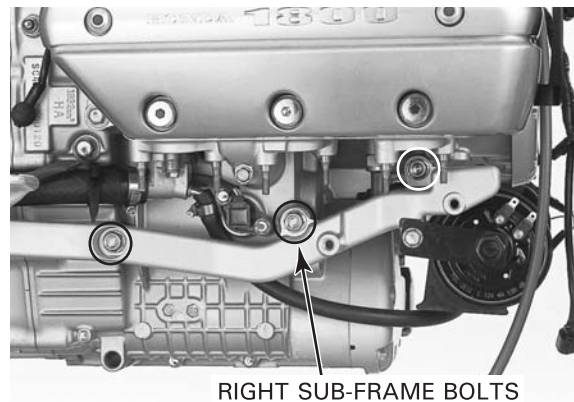

2. Install and tighten the right rear engine hanger bolt.

**TORQUE: 64 N·m (6.5 kgf·m, 47 lbf·ft)**

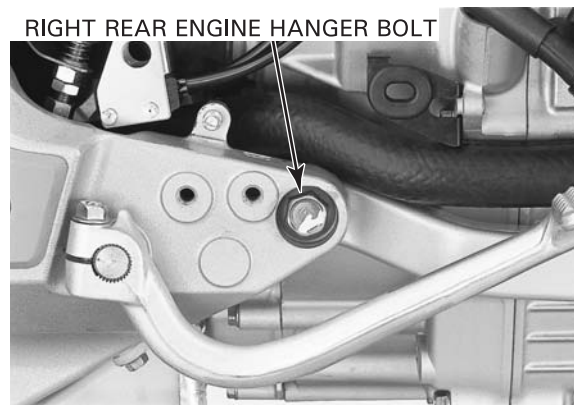

## ENGINE REMOVAL/INSTALLATION

3. Tighten the right front engine hanger bolt.

**TORQUE: 64 N·m (6.5 kgf·m, 47 lbf·ft)**

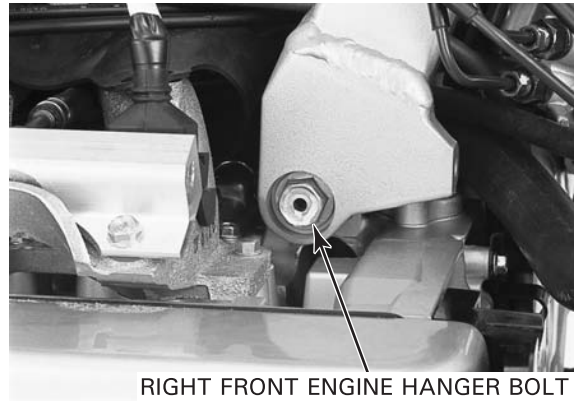

RIGHT FRONT ENGINE HANGER BOLT

4. Tighten the right center engine hanger bolt.

**TORQUE: 39 N·m (4.0 kgf·m, 29 lbf·ft)**

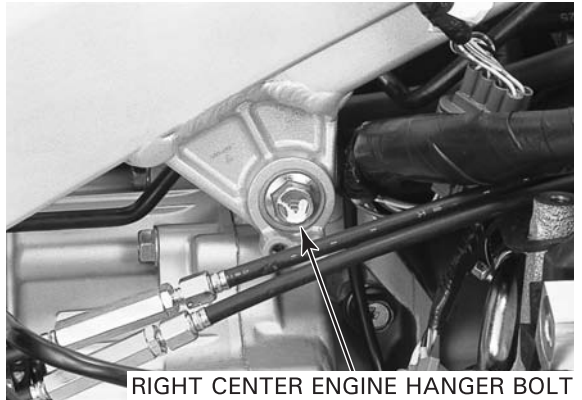

RIGHT CENTER ENGINE HANGER BOLT

5. Tighten the left sub-frame mounting bolts.

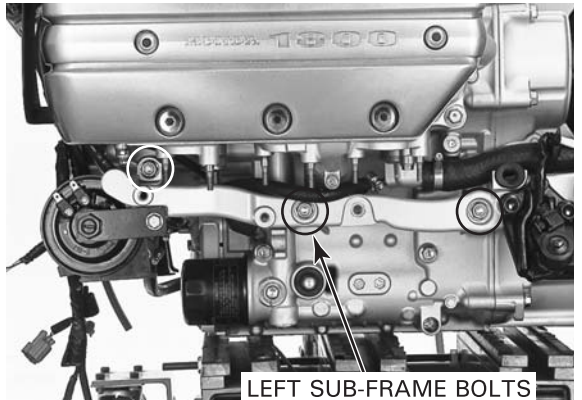

LEFT SUB-FRAME BOLTS

6. Tighten the left rear engine hanger adjusting bolt until it contacts the engine.

**TORQUE: 4 N·m (0.4 kgf·m, 2.9 lbf·ft)**



LEFT REAR ADJUSTING BOLT

## ENGINE REMOVAL/INSTALLATION

7. Install the lock nut onto the left rear engine hanger adjusting bolt. Hold the adjusting bolt and tighten the lock nut using the special tool.

**TOOL:**

**Lock nut wrench**                      **07908-ME90000 or  
07GMA-KT7A200  
(U.S.A. only)**

**TORQUE: 54 N·m (5.5 kgf·m, 40 lbf·ft)**

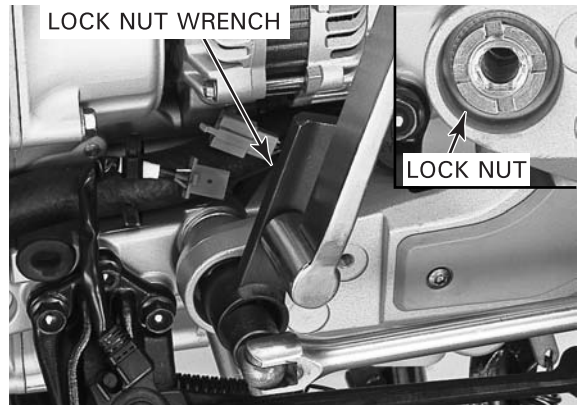

8. Remove the left center engine hanger bolt. Tighten the left center engine hanger adjusting bolt until it contacts the engine.

**TORQUE: 4 N·m (0.4 kgf·m, 2.9 lbf·ft)**

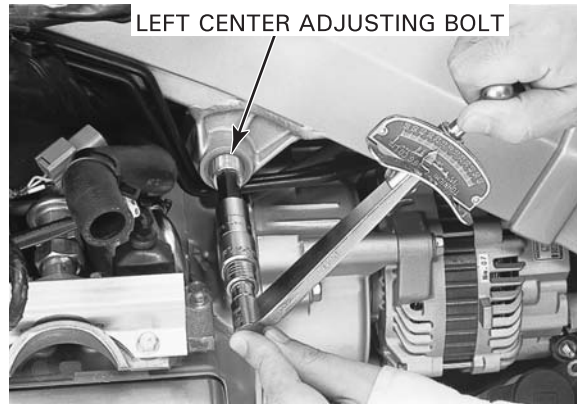

9. Install the lock nut onto the left center engine hanger adjusting bolt. Hold the adjusting bolt and tighten the lock nut using the special tool.

**TOOL:**

**Lock nut wrench**                      **07VMA-MBB0101**

**TORQUE: 54 N·m (5.5 kgf·m, 40 lbf·ft)**

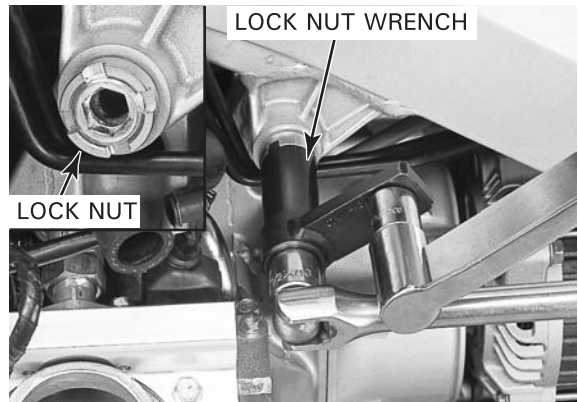

10. Remove the left front engine hanger bolt. Tighten the left front engine hanger adjusting bolt until it contacts the engine.

**TORQUE: 2 N·m (0.2 kgf·m, 1.4 lbf·ft)**

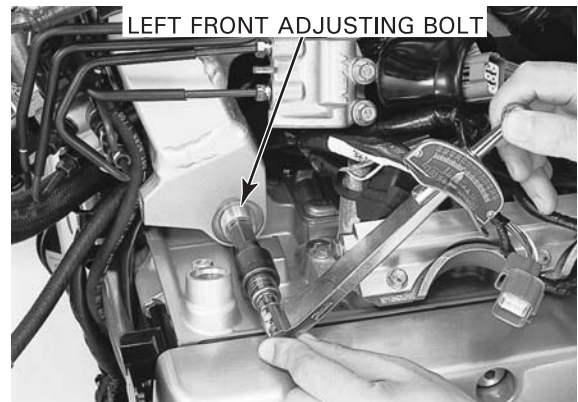

## ENGINE REMOVAL/INSTALLATION

11. Install the lock nut onto the left front engine hanger adjusting bolt. Hold the adjusting bolt and tighten the lock nut using the special tool.

**TOOL:**

**Lock nut wrench**

**07908-ME90000 or  
07GMA-KT7A200  
(U.S.A. only)**

**TORQUE: 54 N·m (5.5 kgf·m, 40 lbf·ft)**

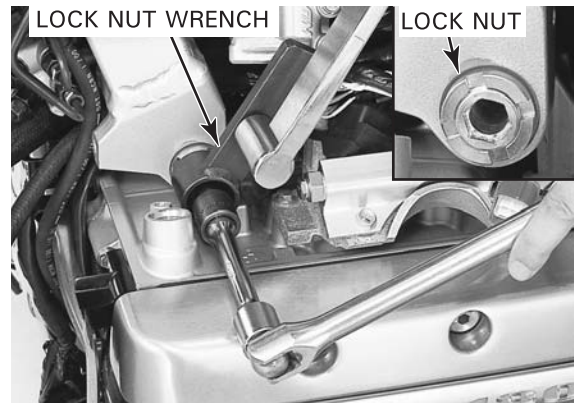

12. Install and tighten the left rear engine hanger bolt.

**TORQUE: 64 N·m (6.5 kgf·m, 47 lbf·ft)**

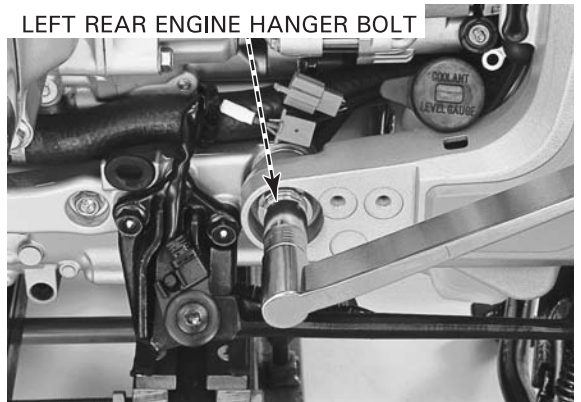

13. Install and tighten the left front engine hanger bolt.

**TORQUE: 64 N·m (6.5 kgf·m, 47 lbf·ft)**

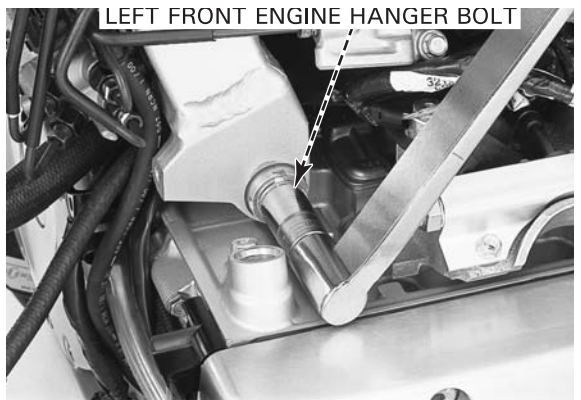

14. Install and tighten the left center engine hanger bolt.

**TORQUE: 39 N·m (4.0 kgf·m, 29 lbf·ft)**

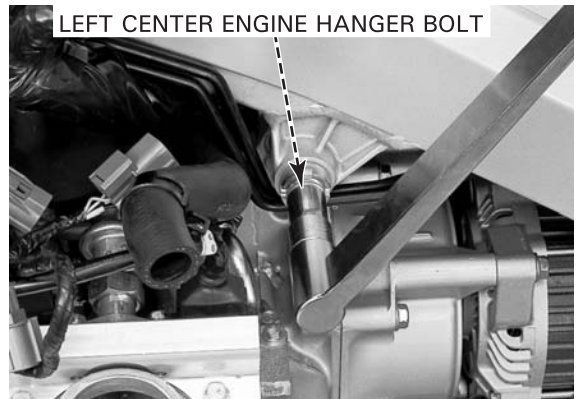



## ENGINE REMOVAL/INSTALLATION

Route the fuel feed hose properly page 1-23.

Coat a new O-ring with oil and install it into the fuel feed hose joint groove.

Install the fuel feed hose joints onto the fuel rail and tighten the joint bolts.

**TORQUE: 10 N-m (1.0 kgf-m, 7 lbf-ft)**

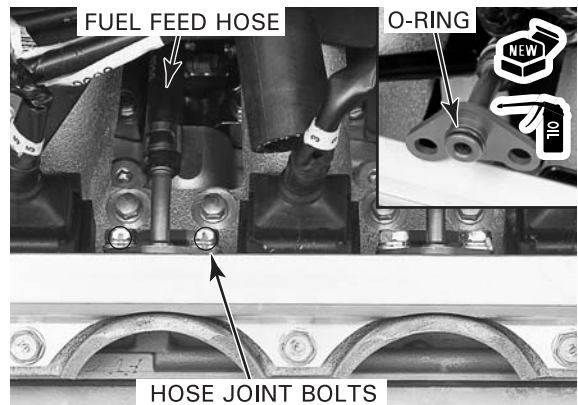

Apply grease to the rider footpeg sliding areas. Install both rider footpegs onto the frame and tighten the mounting bolts.

**TORQUE: 26 N-m (2.7 kgf-m, 20 lbf-ft)**

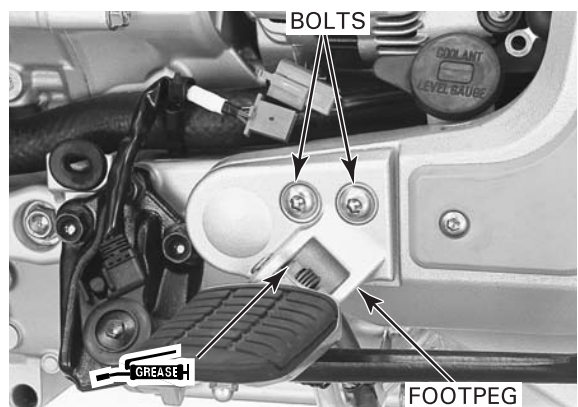

Install both engine guards onto the frame and tighten the mounting bolts securely.



Apply grease to the gearshift pedal link tie-rod ball joints and gearshift pedal pivot. Install the gearshift arm onto the gearshift spindle by aligning the slit of the arm with the punch mark on the spindle. Install the pinch bolt and tighten it securely.

Install the washer and gearshift pedal onto the sub-frame and tighten the pivot bolt.

**TORQUE: 26 N-m (2.7 kgf-m, 20 lbf-ft)**

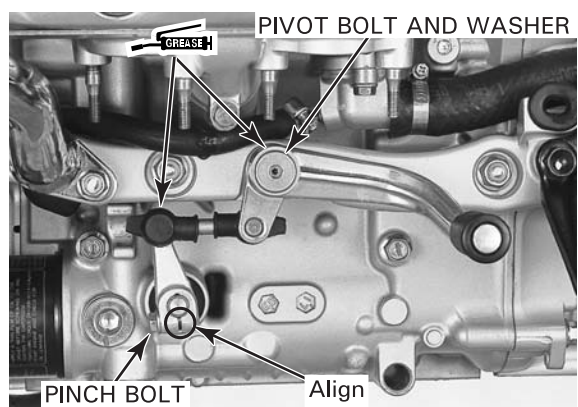

## ENGINE REMOVAL/INSTALLATION

Connect the clutch hose to the clutch slave cylinder with the oil bolt and new sealing washers, and tighten the oil bolt.

**TORQUE: 34 N·m (3.5 kgf·m, 25 lbf·ft)**

Fill and bleed the clutch hydraulic system (page 9-7).

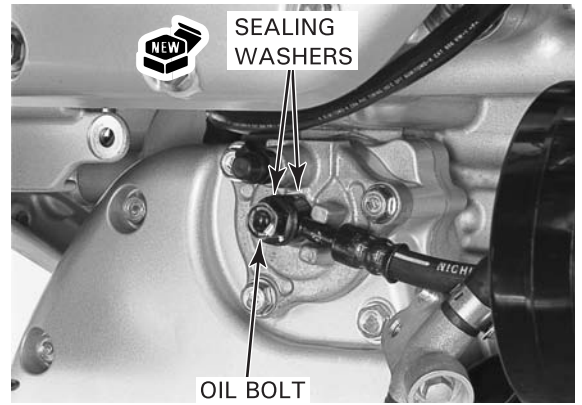

*Route the canister hoses properly (page 1-23).*

Install the coolant drain joint and EVAP canister bracket onto the engine with the two mounting bolts.

Connect the No. 4 and No. 1 hoses to the EVAP canister.

Install the wire band.

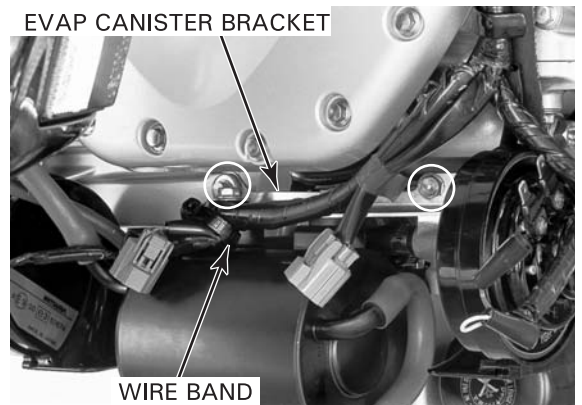

Connect the connectors to both horns.

Connect both knock sensor connectors.

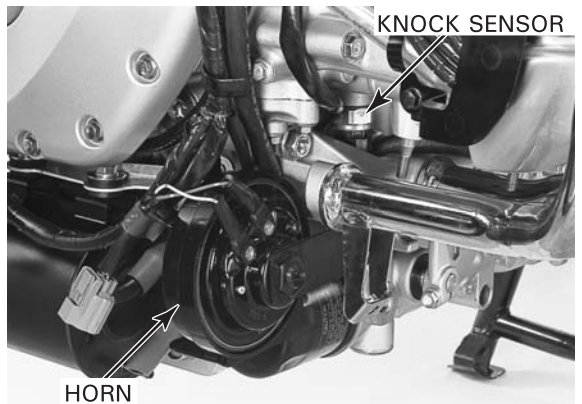

Install the wire clamp onto the No. 2 and No. 5 spark plug wires and install it onto the stay.

Connect the spark plug wires to the ignition coils.

Install the EVAP purge control solenoid valve onto the stay and connect the solenoid valve connector.

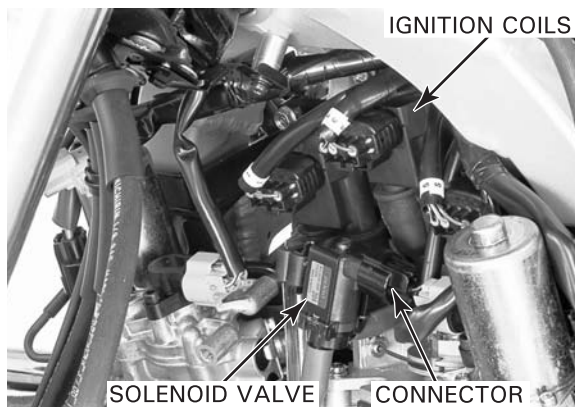

## ENGINE REMOVAL/INSTALLATION

Connect the alternator 4P connector.  
Install the alternator cable and nut onto the alternator terminal and tighten the nut securely.  
Install the rubber cap onto the alternator terminal.  
Connect the side stand switch 3P green connector and install the wire band.

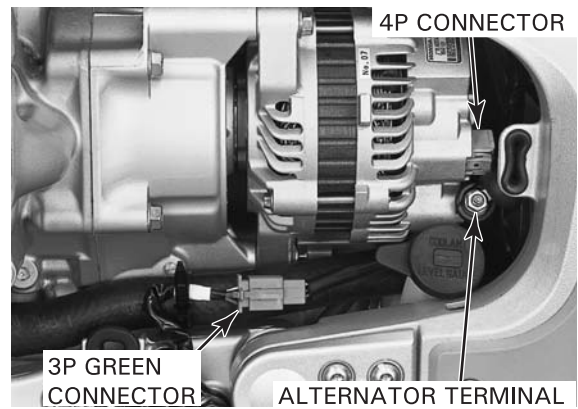

Install the starter/reverse motor cable and nut onto the motor terminal and tighten the nut securely.  
Install the rubber cap onto the starter/reverse motor terminal.

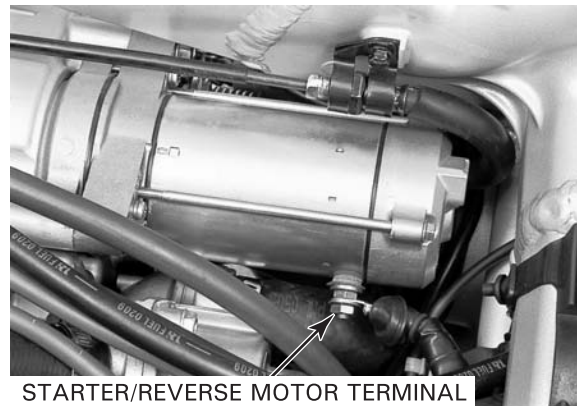

*Do not over-tighten the terminal nut.*

Install the reverse switch wire and nut onto the reverse switch terminal and tighten the nut.

**TORQUE: 2 N-m (0.2 kgf-m, 1.4 lbf-ft)**

Install the rear brake master cylinder reservoir/stay by aligning the stay tab with the hole in the crankcase.

Install the stay bolt and tighten it securely.

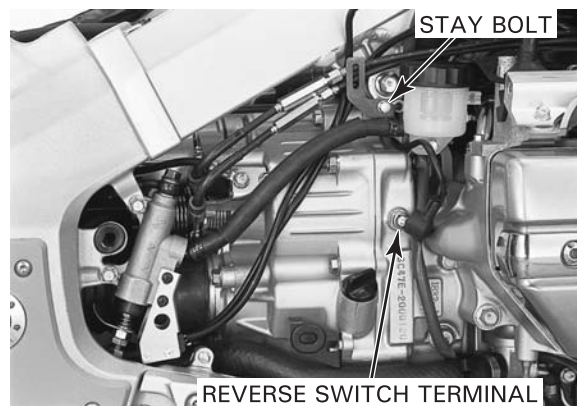

Connect the right engine sub-wire harness 8P gray and speed sensor 3P white connectors.

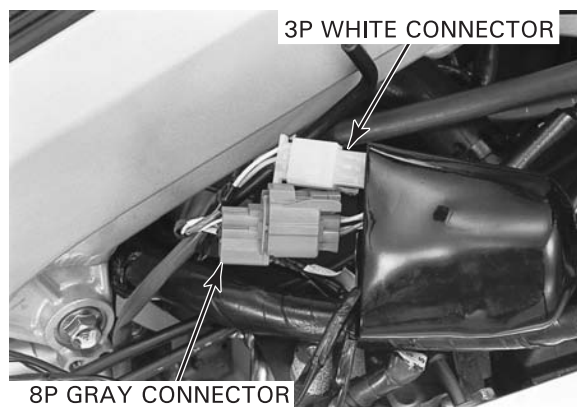



## ENGINE REMOVAL/INSTALLATION

Connect the left engine sub-wire harness 4P gray and 6P gray connectors.

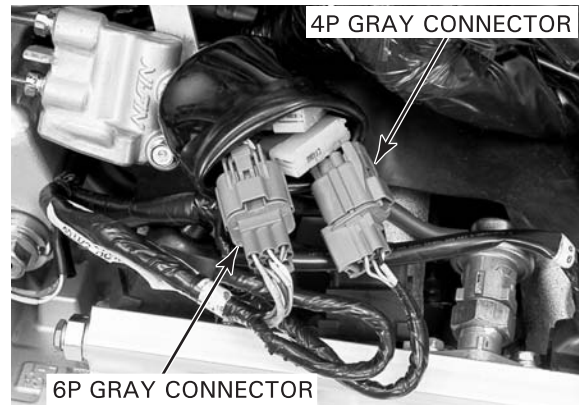

Connect the ignition pulse generator 2P red connector.  
Connect the reverse shift actuator 3P red and 2P white connectors.  
Connect the gear position switch 6P black connector.

Install the following:

- radiator stay and both injector covers
- throttle body (page 5-60)
- radiator reserve tank (page 6-7)
- exhaust system (page 2-20)
- center inner fairing (page 2-6)
- both engine side covers (page 2-5)
- both side covers (page 2-5)

Fill the crankcase with the recommended engine oil if drained (page 3-11).



---

**MEMO**

---

# 8. CYLINDER HEAD/VALVE

---

COMPONENT LOCATION .....	8-2	CYLINDER HEAD DISASSEMBLY .....	8-16
SERVICE INFORMATION .....	8-3	VALVE GUIDE REPLACEMENT .....	8-19
TROUBLESHOOTING .....	8-5	VALVE SEAT INSPECTION/REFACING .....	8-19
CYLINDER COMPRESSION .....	8-6	CYLINDER HEAD ASSEMBLY .....	8-22
CYLINDER HEAD COVER REMOVAL .....	8-6	CYLINDER HEAD INSTALLATION .....	8-24
CAMSHAFT REMOVAL .....	8-7	CAM CHAIN INSTALLATION .....	8-26
CAM CHAIN REMOVAL .....	8-12	CAMSHAFT INSTALLATION .....	8-28
CYLINDER HEAD REMOVAL .....	8-14	CYLINDER HEAD COVER INSTALLATION .....	8-32

# CYLINDER HEAD/VALVE COMPONENT LOCATION

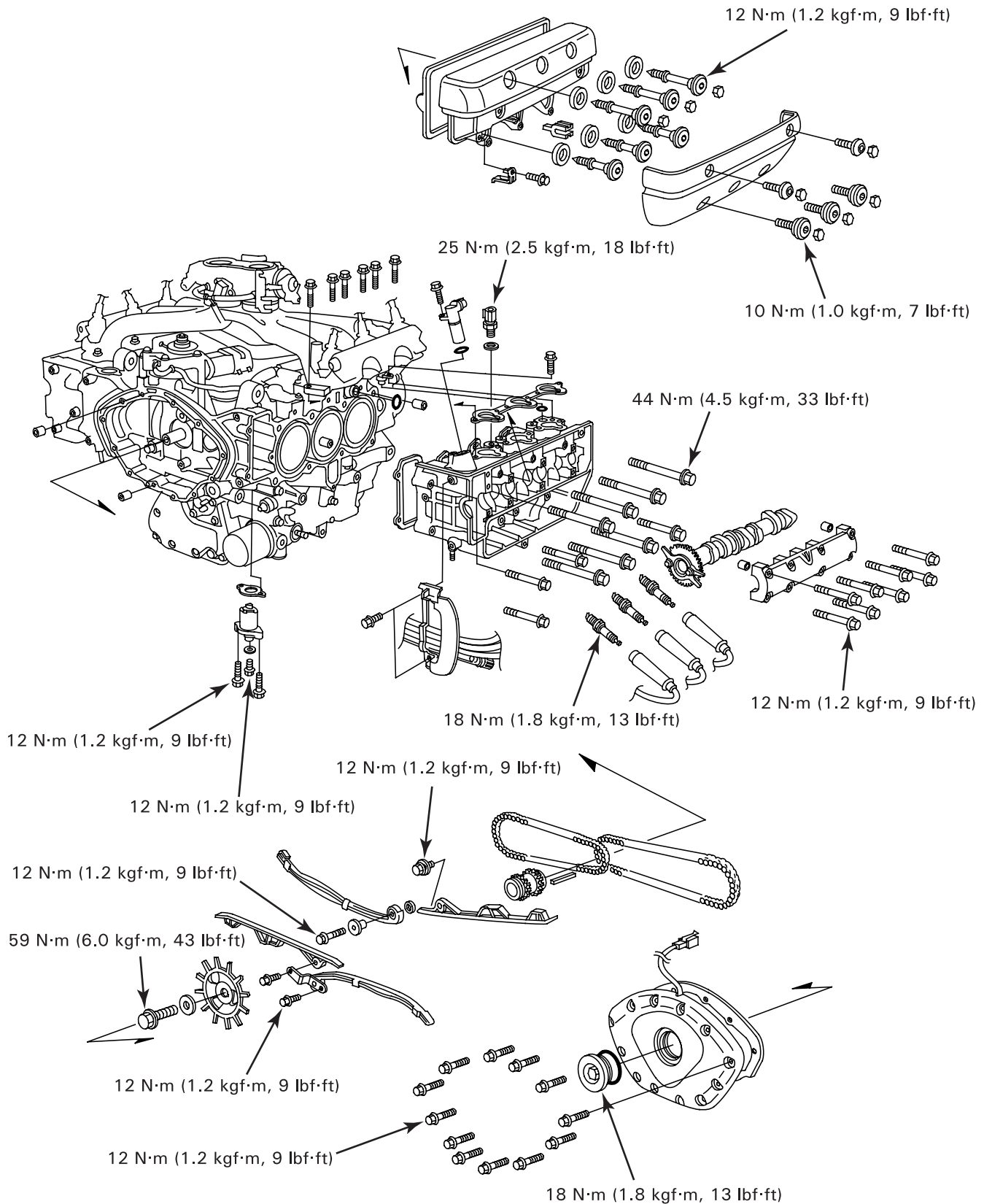

# SERVICE INFORMATION

## GENERAL

- This section covers service of the camshaft, cylinder head and valves.
- The camshaft, cylinder head and valves can be serviced with the engine installed in the frame.
- When disassembling, mark and store the disassembled parts to ensure that they are reinstalled in their original locations.
- Clean all disassembled parts with cleaning solvent and dry them by blowing them off with compressed air before inspection.
- Camshaft lubricating oil is fed through oil passages in the cylinder head. Clean the oil passages before assembling the cylinder head.
- Be careful not to damage the mating surfaces when removing the cylinder head cover and cylinder head.

## SPECIFICATIONS

Unit: mm (in)







ITEM		STANDARD	SERVICE LIMIT
Cylinder compression at 300 rpm		1,383 kPa (14.1 kgf/cm <sup>2</sup> , 201 psi)	-
Valve clearance		IN	0.15 (0.006)
		EX	0.22 (0.009)
Camshaft	Cam lobe height	IN	41.610 – 41.690 (1.6382 – 1.6413)
		EX	41.680 – 41.760 (1.6409 – 1.6441)
	Runout	—	0.03 (0.001)
	Journal O.D.	27.959 – 27.980 (1.1007 – 1.1016)	27.96 (1.101)
	Journal I.D.	28.000 – 28.021 (1.1024 – 1.1032)	28.05 (1.104)
	Oil clearance	0.020 – 0.062 (0.0008 – 0.0024)	0.10 (0.004)
Valve lifter	Valve lifter O.D.	IN/EX	28.978 – 28.993 (1.1409 – 1.1415)
	Valve lifter bore I.D.	IN/EX	29.010 – 29.026 (1.1421 – 1.1428)
Valve, valve guide	Valve stem O.D.	IN	4.970 – 4.995 (0.1957 – 0.1967)
		EX	4.955 – 4.980 (0.1951 – 0.1961)
	Valve guide I.D.	IN/EX	5.000 – 5.012 (0.1969 – 0.1973)
	Stem-to-guide clearance	IN	0.005 – 0.042 (0.0002 – 0.0017)
		EX	0.020 – 0.057 (0.0008 – 0.0022)
	Valve guide projection above cylinder head	IN/EX	11.8 – 12.0 (0.46 – 0.47)
Valve seat width	IN/EX	0.9 – 1.1 (0.035 – 0.043)	
Valve spring	Free length	IN/EX	38.20 (1.504)
Cylinder head warpage		-	0.10 (0.004)

## TORQUE VALUES

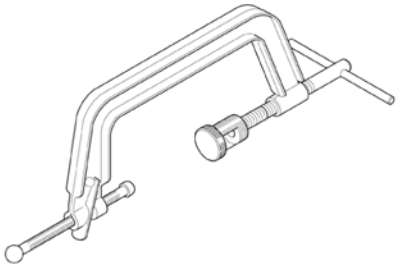
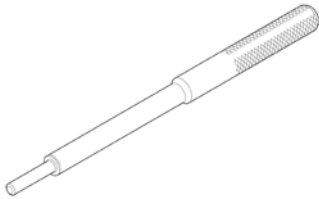
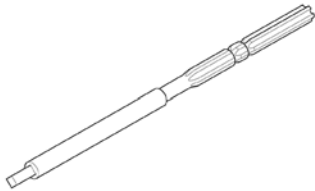
Spark plug	18 N·m (1.8 kgf·m, 13 lbf·ft)	Apply grease to the threads. Apply engine oil to the threads and seating surface.
Timing hole cap	18 N·m (1.8 kgf·m, 13 lbf·ft)	
Cylinder head 9 mm bolt	44 N·m (4.5 kgf·m, 33 lbf·ft)	
Engine coolant temperature sensor	25 N·m (2.5 kgf·m, 18 lbf·ft)	Apply engine oil to the threads and seating surface. Apply locking agent to the threads.
Left cam chain guide washer bolt	12 N·m (1.2 kgf·m, 9 lbf·ft)	
Cam chain tensioner pivot bolt	12 N·m (1.2 kgf·m, 9 lbf·ft)	
Ignition pulse generator rotor bolt	59 N·m (6.0 kgf·m, 43 lbf·ft)	
Ignition pulse generator bolt	12 N·m (1.2 kgf·m, 9 lbf·ft)	
Front crankcase cover bolt	12 N·m (1.2 kgf·m, 9 lbf·ft)	
Cam sprocket bolt	25 N·m (2.6 kgf·m, 19 lbf·ft)	Apply engine oil to the threads and seating surface.
Camshaft holder bolt	12 N·m (1.2 kgf·m, 9 lbf·ft)	
Cam chain tensioner lifter mounting bolt	12 N·m (1.2 kgf·m, 9 lbf·ft)	
Cam chain tensioner lifter sealing bolt	12 N·m (1.2 kgf·m, 9 lbf·ft)	
Cylinder head cover bolt	12 N·m (1.2 kgf·m, 9 lbf·ft)	
Cylinder head side cover bolt	10 N·m (1.0 kgf·m, 7 lbf·ft)	

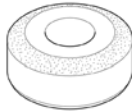
# CYLINDER HEAD/VALVE

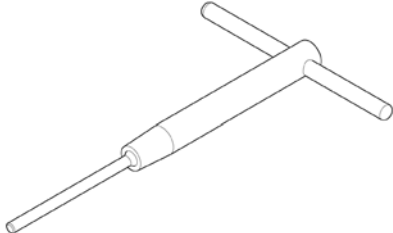
## TOOLS

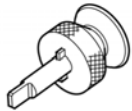
<p>Valve spring compressor 07757-0010000</p> 	<p>Valve guide driver, 5.0 mm 07942-MA60000</p>  <p>or 07942-8920000</p>	<p>Valve guide reamer, 5.0 mm 07984-MA60001</p>  <p>or 07984-MA6000D</p>
<p>Valve seat cutter, 33 mm (45° IN) 07780-0010800</p>  <p>or equivalent commercially available in U.S.A.</p>	<p>Valve seat cutter, 29 mm (45° EX) 07780-0010300</p>  <p>or equivalent commercially available in U.S.A.</p>	<p>Flat cutter, 35 mm (32° IN) 07780-0012300</p>  <p>or equivalent commercially available in U.S.A.</p>
<p>Flat cutter, 33 mm (32° EX) 07780-0012900</p>  <p>or equivalent commercially available in U.S.A.</p>	<p>Interior cutter, 30 mm (60° IN/EX) 07780-0014000</p>  <p>or equivalent commercially available in U.S.A.</p>	<p>Cutter holder, 6.6 mm 07781-0010400</p>  <p>or equivalent commercially available in U.S.A.</p>
<p>Tensioner holder A 07ZMG-MCAA300</p> 	<p>Tensioner holder B 07ZMG-MCAA400</p>  <p>without rod and cord</p>	

## **TROUBLESHOOTING**

Engine top-end problems usually affect engine performance. These can be diagnosed by a compression test, or by tracing top-end noise with a sounding rod or stethoscope.

### **Compression too low, hard starting or poor performance at low speed**

- Valves
  - Incorrect valve adjustment
  - Burned or bent valves
  - Incorrect valve timing
  - Broken valve spring
  - Uneven valve seating
- Cylinder head
  - Leaking or damaged cylinder head gasket
  - Warped or cracked cylinder head
  - Loose spark plug
- Cylinder/piston problem (section 11)

### **Compression too high**

- Excessive carbon build-up on piston head or combustion chamber

### **Excessive smoke**

- Worn valve stem or valve guide
- Damaged stem seal
- Cylinder/piston problem (section 11)

### **Excessive noise**

- Incorrect valve clearance
- Sticking valve or broken valve spring
- Worn or damaged camshaft
- Worn or damaged valve lifter
- Worn cam chain
- Worn cam sprocket teeth
- Worn or damaged cam chain tensioner
- Cylinder/piston problem (section 11)

### **Rough idle**

- Low cylinder compression



## CYLINDER HEAD/VALVE

### CYLINDER COMPRESSION

Warm up the engine to normal operating temperature. Stop the engine.

Remove the seat (page 2-5) and disconnect the 5P gray connector from the fuel pump.  
Remove the spark plug caps and spark plugs (page 3-8).

Install the compression gauge into the spark plug hole.  
Shift the transmission into neutral.

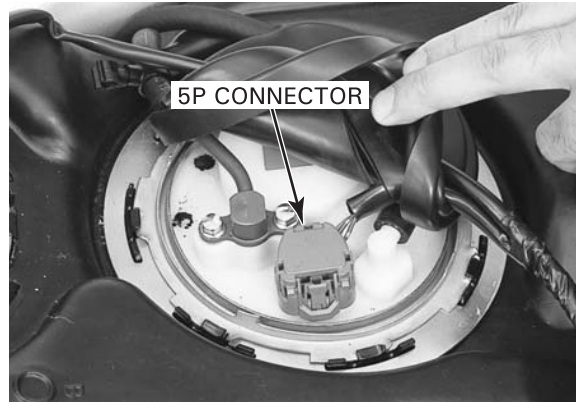

Open the throttle all the way and crank the engine with the starter motor until the gauge reading stops rising. The maximum reading is usually reached within 4-7 seconds.

#### COMPRESSION PRESSURE:

**1,383 kPa (14.1 kgf/cm<sup>2</sup>, 201 psi) at 300 rpm**

Low compression can be caused by:

- blown cylinder head gasket
- improper valve adjustment
- valve leakage
- worn piston ring or cylinder

High compression can be caused by:

- carbon deposits in combustion chamber or on piston head

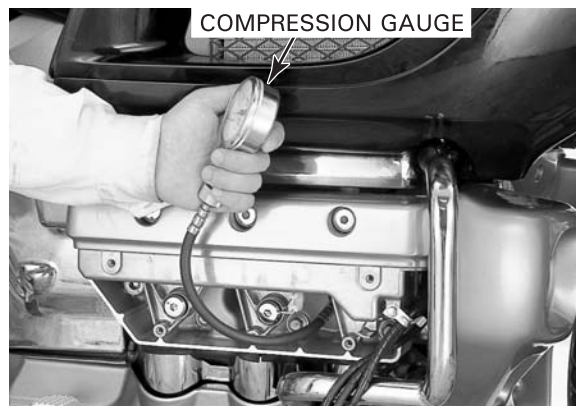

### CYLINDER HEAD COVER REMOVAL

Remove the following:

- five rubber plugs
- five socket bolts
- cylinder head side cover

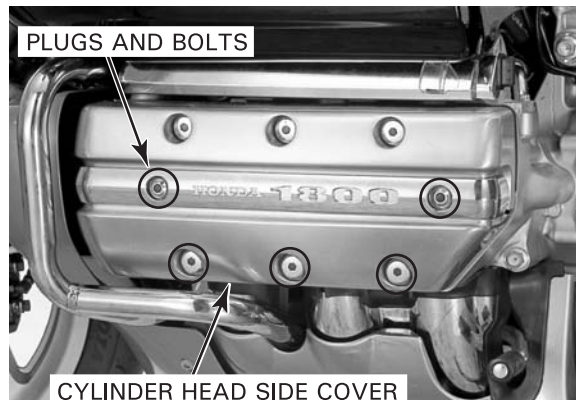

- bolt and wire clamp
- spark plug wires from clip
- three rubber plugs
- six socket bolts (left cylinder head cover)
- five socket bolts (right cylinder head cover)
- cylinder head cover

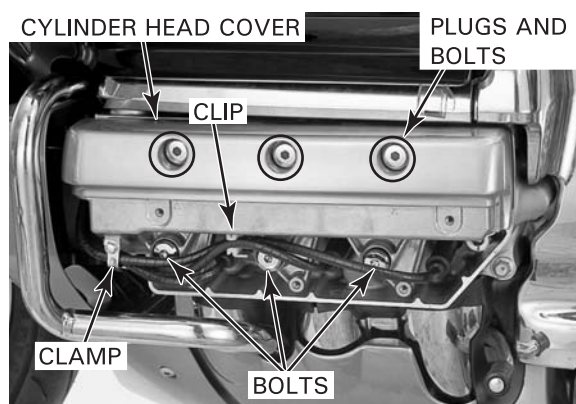

## CAMSHAFT REMOVAL

- Right camshaft:* Remove the following:
- right inner fairing (page 2-6)
  - cylinder head cover (page 8-6)

Remove the cam chain tensioner lifter bolt and sealing washer.



Wind the string clockwise around the tool. Insert the rod through the ring and screw the rod into the tool.

**TOOL:**  
**Tensioner holder A**                      **07ZMG-MCAA300**

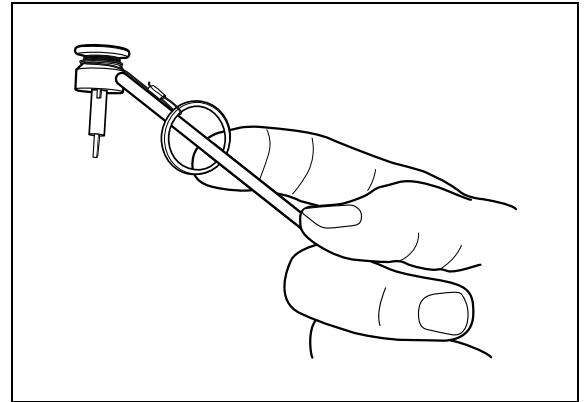

Pull both coolant hoses out of the way and insert the special tool into the tensioner body. Push the special tool into the tensioner so the blade of the tool is in the tensioner and the tabs are just above the slots in the tensioner. (There should be space between the bottom of the tool and the tensioner body; do not engage the teeth on the special tool with the slots in the tensioner body.)

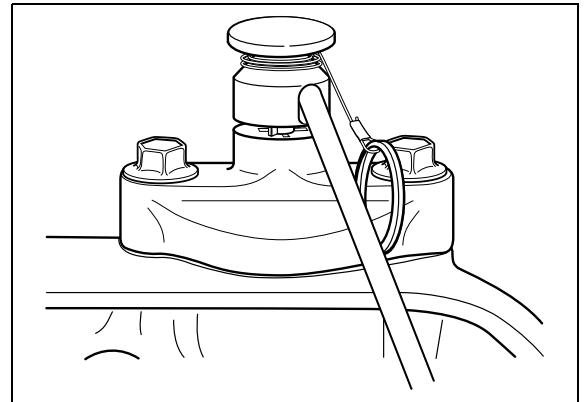

Unscrew the rod from the tool and pull the ring until the tool stops turning (the tensioner lifter shaft is fully secured with the special tool). Make sure the teeth are fully engaged into the tensioner before pulling the string.

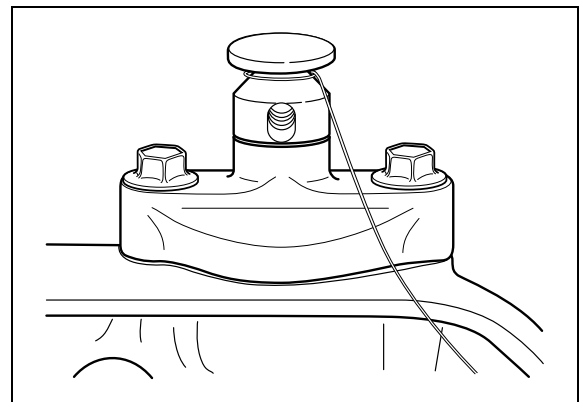

## CYLINDER HEAD/VALVE

- Left camshaft:* Remove the following:
- front lower fairing (page 2-6)
  - left horn connectors
  - bolt and left horn
  - cylinder head cover (page 8-6)

*Keep some rags handy because oil will drip out of the left cam chain tensioner.* Remove the cam chain tensioner lifter bolt and sealing washer.

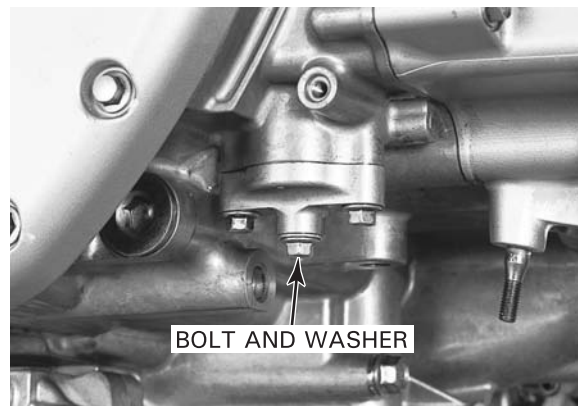
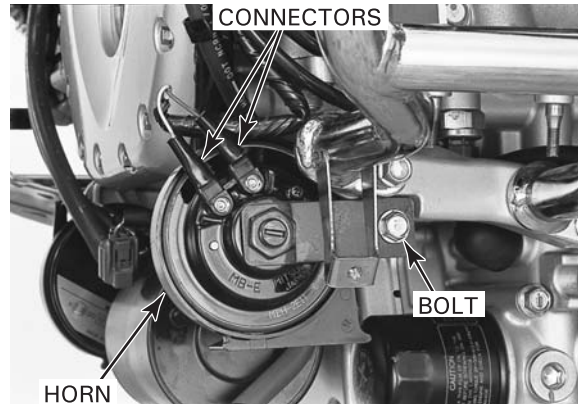

Install the special tool into the tensioner body so the blade of the tool is in the tensioner and the tabs are just above the slots in the tensioner. (There should be space between the bottom of the tool and the tensioner body; do not engage the teeth on the special tool with the slots in the tensioner body.)

Turn the tool clockwise until it stops turning (the tensioner lifter shaft is fully secured with the special tool).

**TOOL:**  
**Tensioner holder B**  
 (without rod and cord)      **07ZMG-MCAA400**

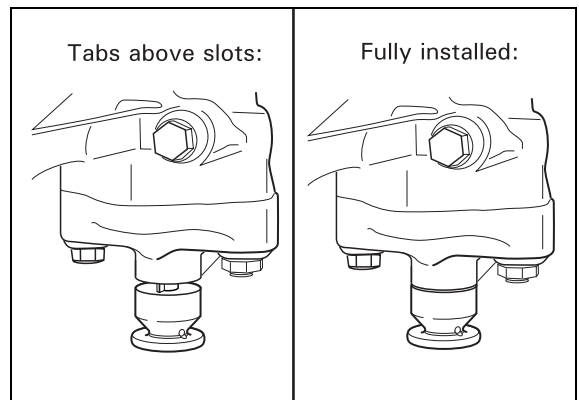

Remove the timing hole cap.

Rotate the crankshaft counterclockwise and align the 1.2 TF mark on the ignition pulse generator rotor with the index mark in the front crankcase cover.

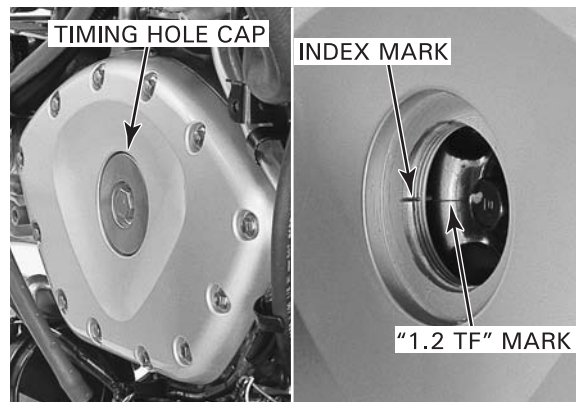

The timing marks on the cam sprocket must be flush with the cylinder head surface and make sure the rear end cam lobe is facing outward (TDC on exhaust stroke).  
 If the rear end cam lobe is facing inward (TDC on compression stroke), rotate the crankshaft counterclockwise 360° (one full turn) so the rear end cam lobe faces out.

*Do not forcibly remove the dowel pins from the camshaft holder.*

Loosen the camshaft holder bolts in a crisscross pattern in several steps from the outside to inside to prevent damaging the camshaft holder and camshaft.

Remove the camshaft holder.

Remove the cam chain off the cam sprocket, being careful not to damage the cylinder head and camshaft and then remove the camshaft.

*Be careful not to jam the removed cam chain into the timing sprocket of the crankshaft when rotating the crankshaft.*

Rotate the crankshaft counterclockwise 360° (one full turn) and align the 1.2TF mark on the ignition pulse generator rotor with the index mark in the front crankcase cover.

Be sure that the timing marks on the cam sprocket are flush with the cylinder head surface and that the rear end cam lobe is facing outward (TDC on exhaust stroke).

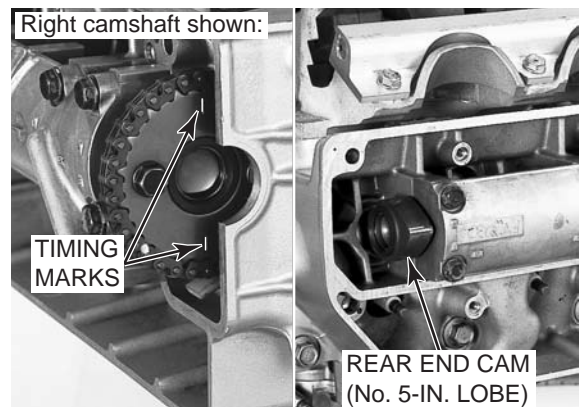
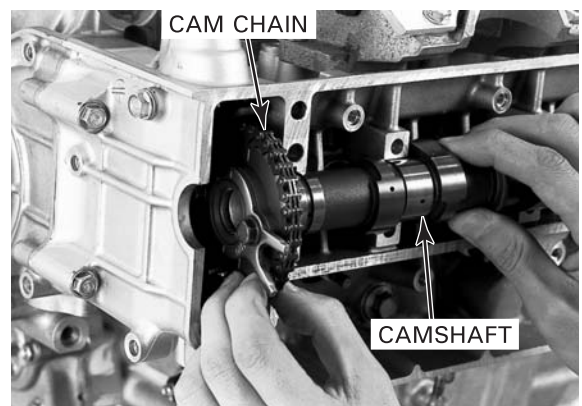
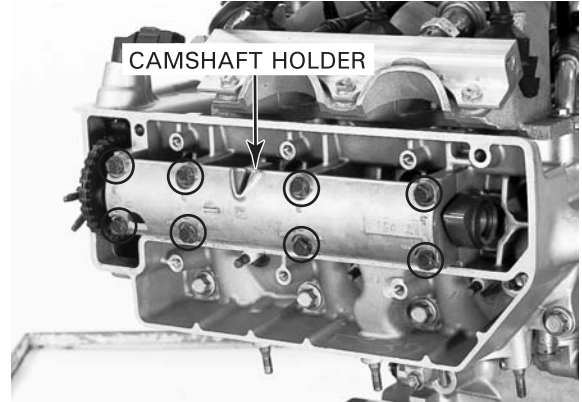
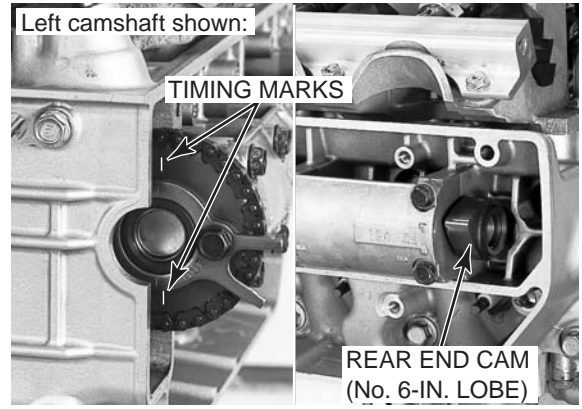



## CYLINDER HEAD/VALVE

Loosen the camshaft holder bolts in a crisscross pattern in several steps from the outside to inside to prevent damaging the camshaft holder and camshaft.

Remove the camshaft holder.

Remove the cam chain off the cam sprocket, being careful not to damage the cylinder head and camshaft and then remove the camshaft.

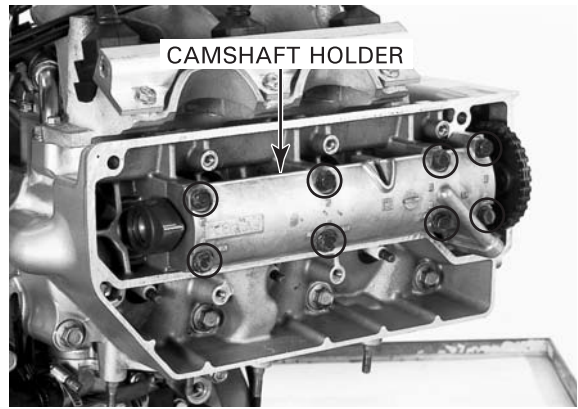

Remove the valve lifters and shims.

### NOTE:

- Be careful not to damage the valve lifter bores.
- The shims may stick to the inside of the valve lifters. Do not allow the shims to fall into the cylinder head.
- Mark all valve lifters and shims to ensure correct reassembly in their original locations.
- The valve lifters can be easily removed with a valve lapping tool or magnet.
- The shims can be easily removed with tweezers or a magnet.

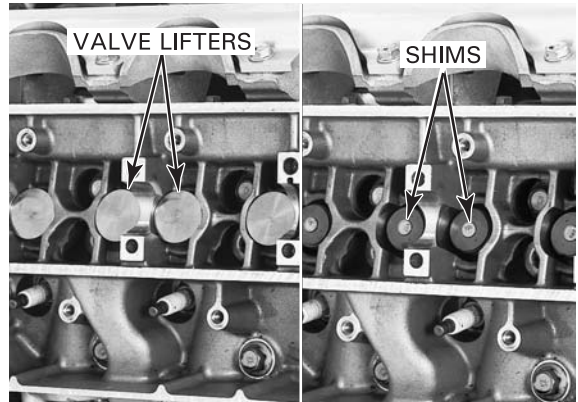

## INSPECTION

### CAMSHAFT

Check the cam sprocket for wear or damage.

Check the cam and journal surfaces of the camshaft for scoring, scratches or evidence of insufficient lubrication.

Check the oil holes in the camshaft for debris.

Measure the camshaft runout using a dial indicator.

**SERVICE LIMIT: 0.03 mm (0.001 in)**

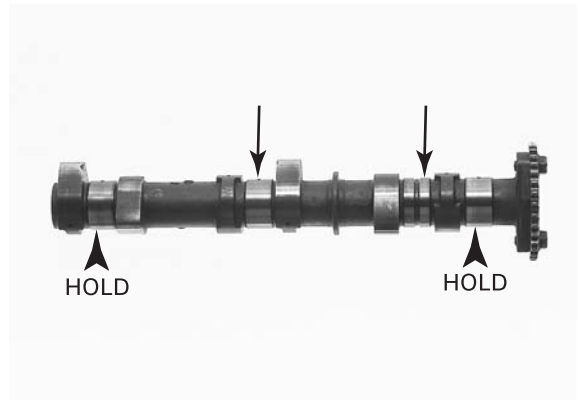

Measure each cam lobe height using a micrometer.

**SERVICE LIMITS: IN: 41.58 mm (1.637 in)**

**EX: 41.65 mm (1.640 in)**

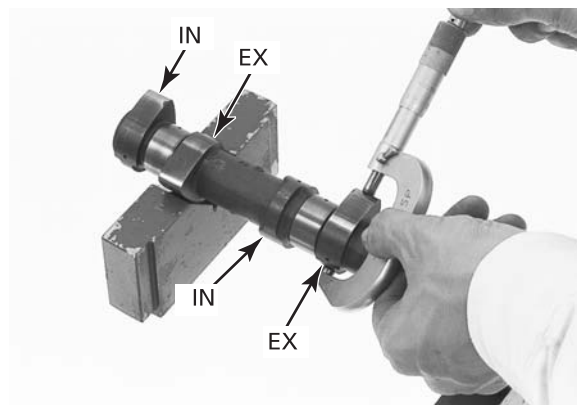

**CAMSHAFT JOURNAL**

Check the camshaft journal surfaces of the camshaft holder and cylinder head for scoring, scratches or evidence of insufficient lubrication.



**CAMSHAFT OIL CLEARANCE**

*Do not rotate the camshaft during inspection.*

Wipe any oil from the journals of the cylinder head, camshaft and camshaft holder. Install the cam chain onto the camshaft sprocket and install the camshaft into the cylinder head (page 8-22). Lay a strip of plastigauge lengthwise on each camshaft journal and be sure to avoid the oil passages.

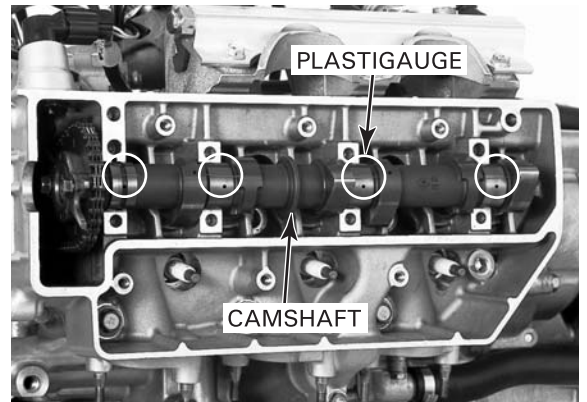

Install the dowel pins and camshaft holder onto the cylinder head, being careful not to drop the plastigauge. Apply oil to the threads and seating surfaces of the camshaft holder bolts and install them.

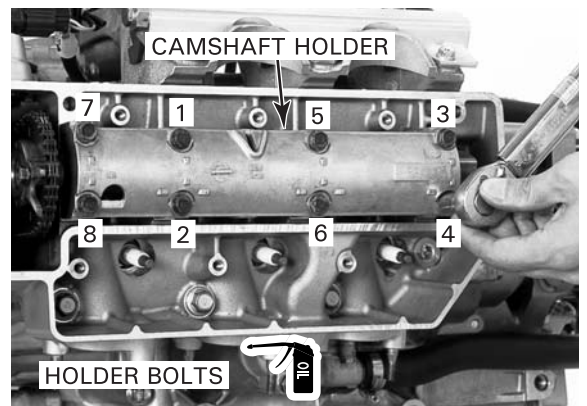

Tighten the holder bolts in several steps according to the numerical order cast on the camshaft holder (1 thru 8).

**TORQUE: 12 N·m (1.2 kgf·m, 9 lbf·ft)**

Remove the camshaft holder and measure the compressed plastigauge at its widest point on the camshaft to determine the oil clearance.

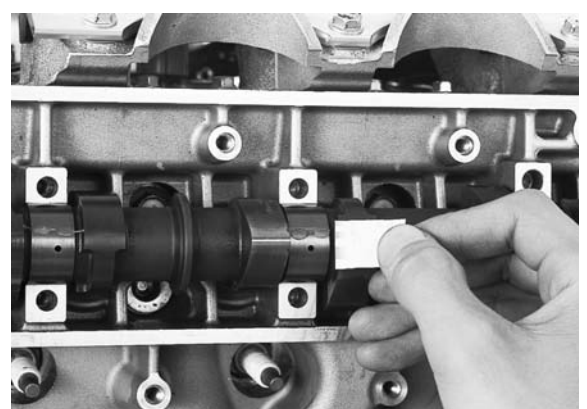

**SERVICE LIMIT: 0.10 mm (0.004 in)**

If the oil clearance exceeds the service limit, replace the camshaft and recheck the oil clearance. Replace the cylinder head and camshaft holder as a set if the oil clearance still exceeds the service limit.

## CYLINDER HEAD/VALVE

### CAM SPROCKET REPLACEMENT

Remove the following:

- cam sprocket bolts
- cam pulse rotor and spacer (left camshaft only)
- cam sprocket

The camshafts have the following identification marks:

L: left cylinder camshaft

R: right cylinder camshaft

Install the cam sprocket with the timing marks facing out and align the bolt holes.

Install the spacer and cam pulse rotor onto the left camshaft with the "OUT" mark on the rotor facing out.

Apply locking agent to the threads of the sprocket bolts. Install the bolts and tighten them.

**TORQUE: 25 N·m (2.6 kgf·m, 19 lbf·ft)**

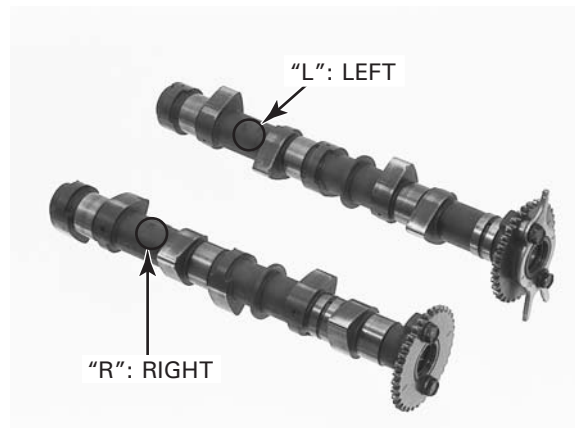
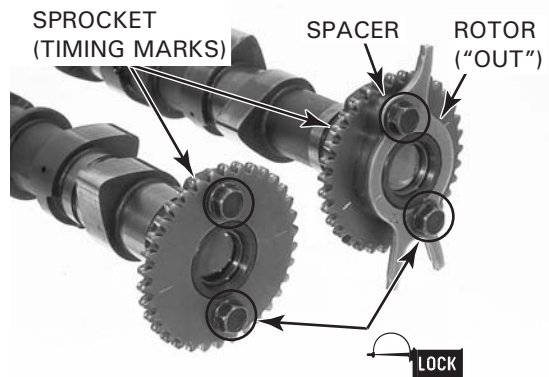

### CAM CHAIN REMOVAL

Remove the camshaft (page 8-7).

*Support the front crankcase cover so that it does not hang from the pulse generator wire.*

Remove the following:

- twelve crankcase cover bolts
- front crankcase cover
- two dowel pins
- two bolts and wire retainer
- ignition pulse generator (grommet)
- gasket

- pulse generator bolt and washer
- ignition pulse generator rotor

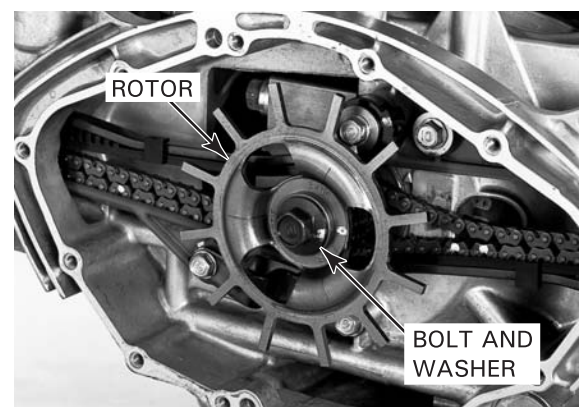
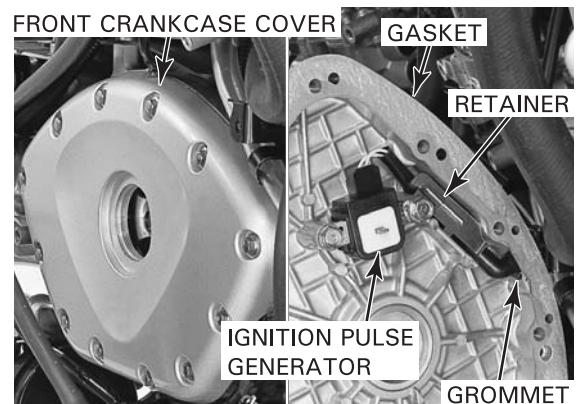



- tensioner pivot bolt and collar
- right cam chain tensioner and washer
- tensioner arm bolts
- left cam chain tensioner

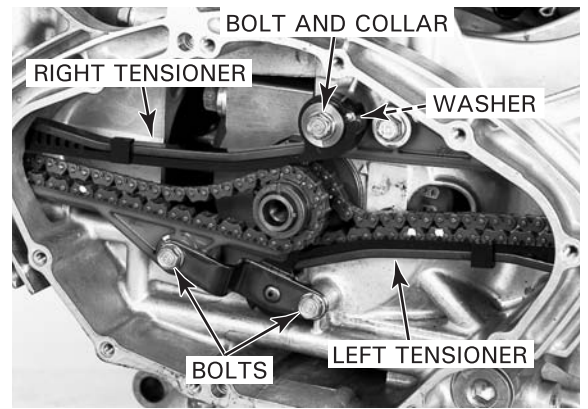

- right cam chain guide
- washer bolt and left cam chain guide
- right and left cam chains

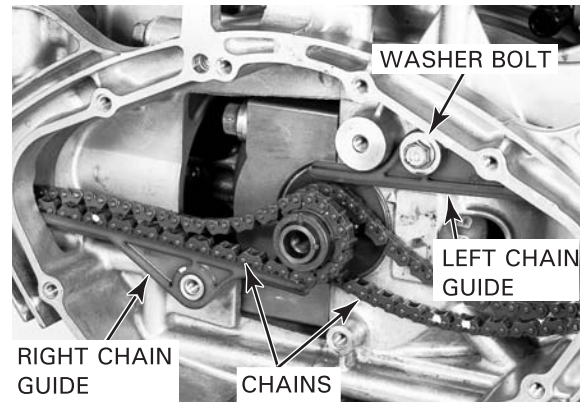

- timing sprocket
- key

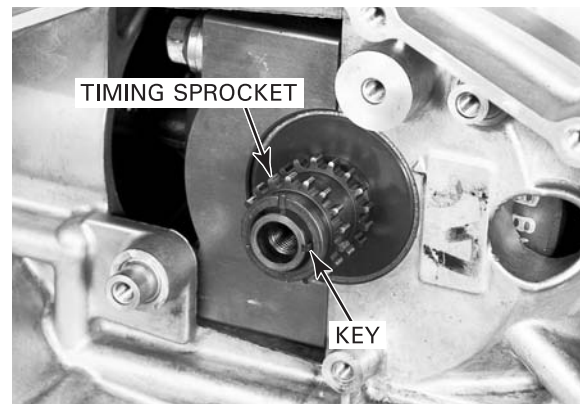

### INSPECTION

#### TIMING SPROCKET/CAM CHAIN

Check the sprocket teeth and chain for wear or damage.

#### CAM CHAIN TENSIONER/GUIDE

Check the tensioner and guide for excessive wear or damage.



## CYLINDER HEAD/VALVE

### CYLINDER HEAD REMOVAL

Remove the following:

- engine side covers (page 2-5)
- left and right radiators (page 6-8)
- air cleaner housing (page 5-57)
- exhaust pipe (page 2-18)
- camshafts (page 8-7)

Remove the socket bolts and the left and right fuel rail covers.

Remove the flange bolts and the left and right radiator stays.

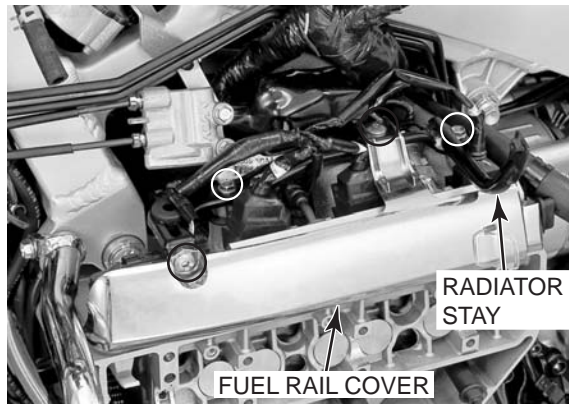

Remove the following from the cylinder head:

- two bolts and guide plate
- spark plug caps
- spark plugs (when the cylinder head is to be disassembled)



- Left cylinder head only:*
- camshaft position sensor 2P black connector
  - bolt and camshaft position sensor
  - O-ring
  - engine coolant temperature (ECT) sensor 3P gray connector

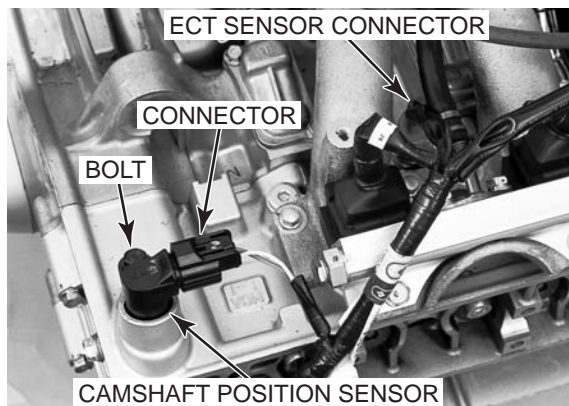

- bolt and water hose joint pipe
- O-ring

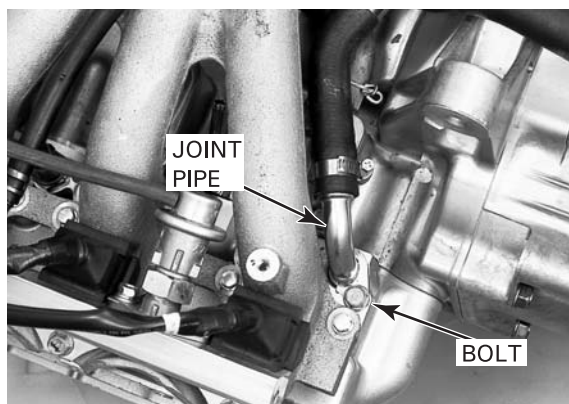

- twelve intake manifold bolts (from the left and right cylinder head)

Raise the intake manifold assembly and set suitable wooden blocks between the crankcase and manifold to support it.

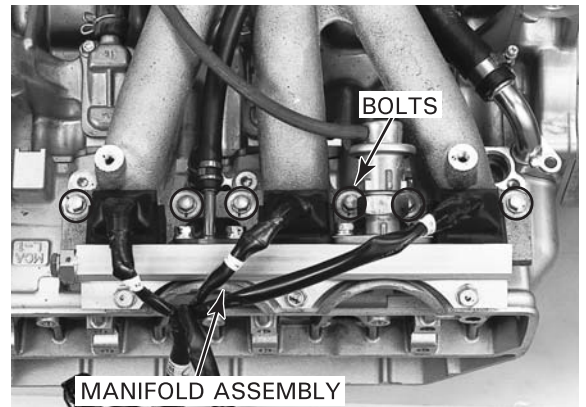

Remove the following from the cylinder head:

- manifold gasket



*Left cylinder head only:*

- ECT sensor and sealing washer

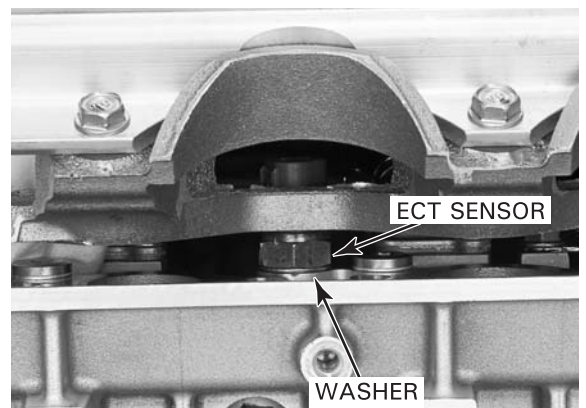

- cylinder head bolts (three 6-mm bolts and eight 9-mm bolts)

Remove the cylinder head while disconnecting the water hose joint pipe, being careful not to damage the mating surface of the manifold and cylinder head.

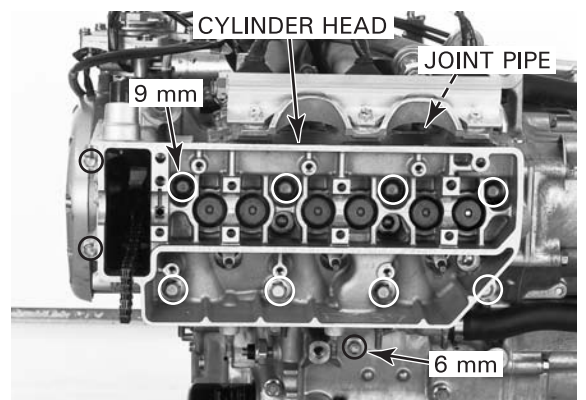



## CYLINDER HEAD/VALVE

Remove the following:

- cylinder head gasket
- two dowel pins
- O-ring from the water hose joint pipe

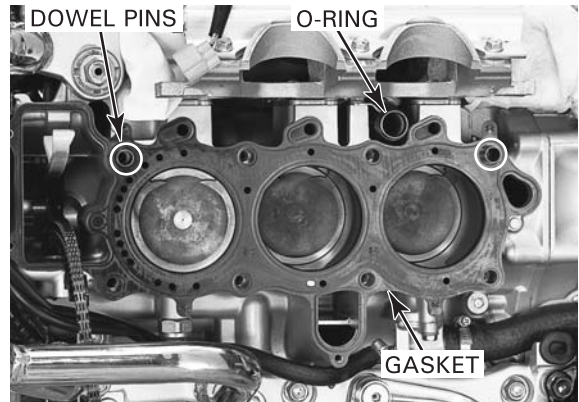

## CYLINDER HEAD DISASSEMBLY

Make a lifter bore protector from a plastic 35-mm film container by cutting the bottom and side wall of the container.

Install the protector into the valve lifter bore.

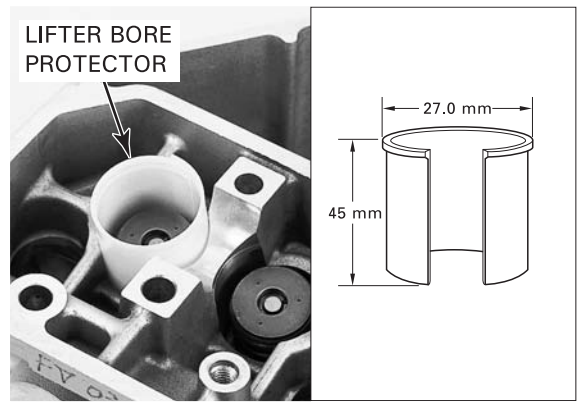

*To prevent loss of tension, do not compress the valve spring more than necessary to remove the cotters.*

Remove the valve spring cotters using the valve spring compressor.

**TOOL:**

**Valve spring compressor**

**07757-0010000**

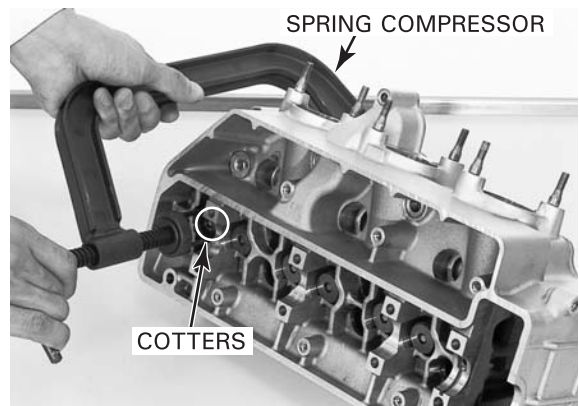

*Mark all parts so they can be placed back in their original locations.*

Remove the following:

- spring retainer
- valve spring
- valve
- stem seal
- spring seat

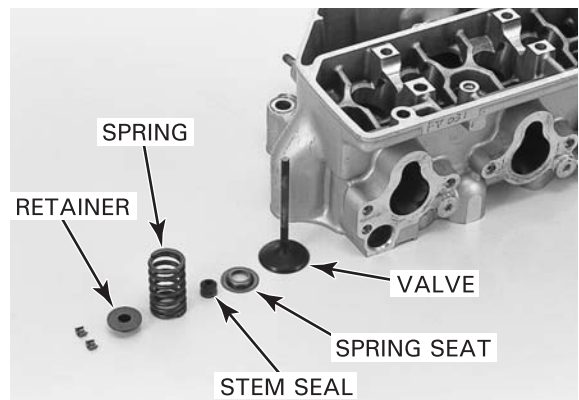

**INSPECTION**

**CYLINDER HEAD**

Remove the carbon deposits from the combustion chamber, being careful not to damage the gasket surface. Check the spark plug hole and valve areas for cracks.

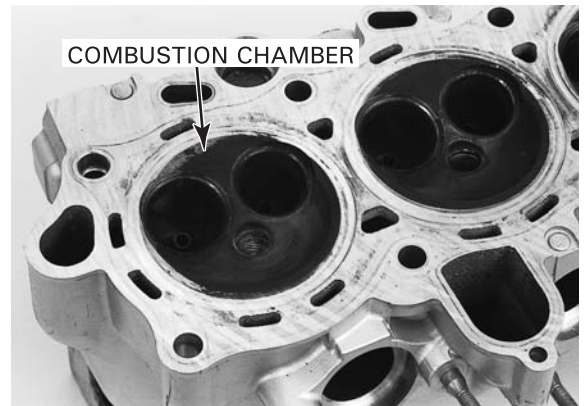

Check the cylinder head for warpage with a straight edge and feeler gauge.

**SERVICE LIMIT: 0.10 mm (0.004 in)**

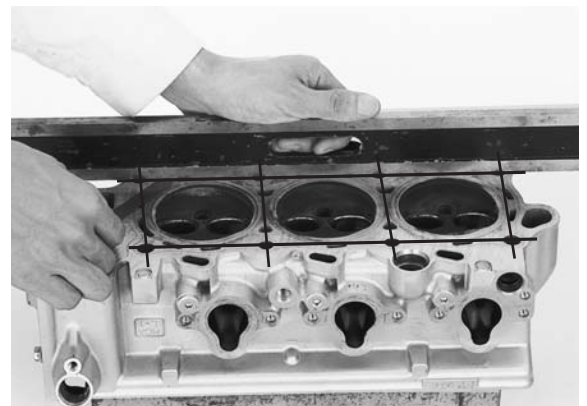

Check the valve lifter bore for scoring, scratches or damage. Measure each valve lifter bore I.D.

**SERVICE LIMIT: 29.04 mm (1.143 in)**



**VALVE LIFTER**

Check the valve lifter for scoring, scratches or damage. Measure each valve lifter O.D.

**SERVICE LIMIT: 28.97 mm (1.141 in)**



## CYLINDER HEAD/VALVE

### VALVE SPRING

Measure the valve spring free length.

**SERVICE LIMITS: IN/EX: 37.0 mm (1.46 in)**

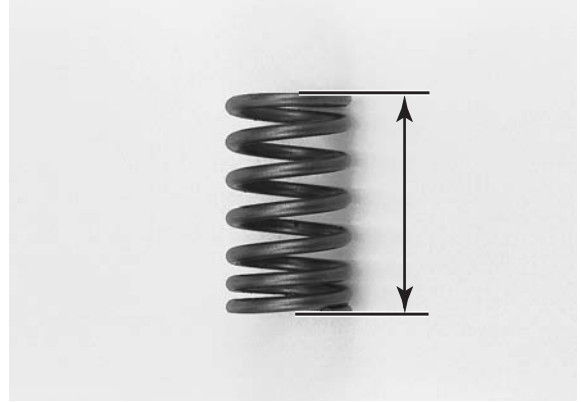

### VALVE/VALVE GUIDE

Check that the valve moves smoothly in the guide. Check the valve for bends, burns or abnormal wear. Measure each valve stem O.D. and record it.

**SERVICE LIMITS: IN: 4.96 mm (0.195 in)**  
**EX: 4.95 mm (0.195 in)**

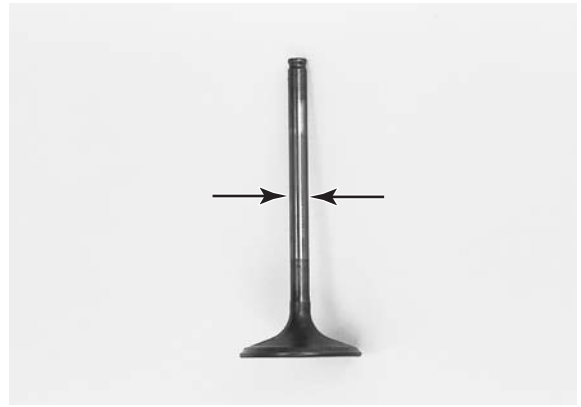

Ream the valve guide to remove any carbon build-up before measuring the guide. Insert the reamer from the combustion chamber side of the head and always rotate the reamer clockwise.

#### TOOL:

Valve guide reamer, 5.0 mm **07984-MA60001** or **07984-MA6000D**

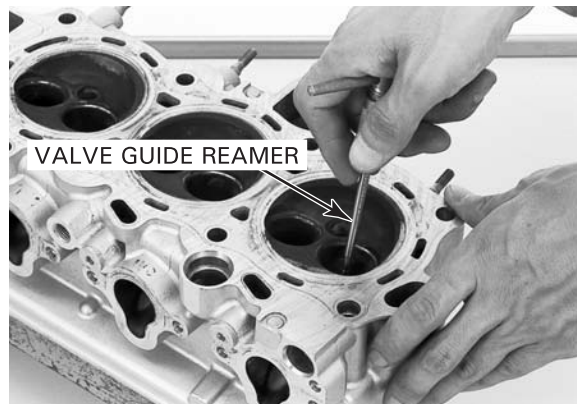

Measure each valve guide I.D. and record it.

**SERVICE LIMIT: IN/EX: 5.04 mm (0.198 in)**

Subtract each valve stem O.D. from the corresponding guide I.D. to obtain the stem-to-guide clearance.

**SERVICE LIMITS: IN: 0.075 mm (0.0030 in)**  
**EX: 0.085 mm (0.0033 in)**

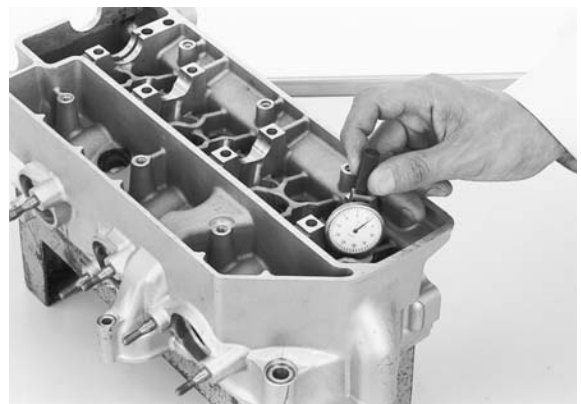

*Inspect and reface the valve seats whenever the valve guides are replaced page 8-19.*

If the stem-to-guide clearance exceeds the service limit, determine if a new guide with standard dimensions would bring the clearance within tolerance.

If so, replace any guides as necessary and ream to fit.

If the stem-to-guide clearance exceeds the service limit with a new guide, also replace the valve.

## VALVE GUIDE REPLACEMENT

Chill the new valve guides in a freezer for about an hour.

*Be sure to wear heavy gloves to avoid burns when handling the heated cylinder head. Using a torch to heat the cylinder head may cause warpage.*

Heat the cylinder head to 130–140°C (275–290°F) with a hot plate or oven. Do not heat the cylinder head beyond 150°C (300°F). Use temperature indicator sticks, available from welding supply stores, to be sure the cylinder head is heated to the proper temperature.

Support the cylinder head and drive the valve guides out of the cylinder head from the combustion chamber side.

### TOOL:

**Valve guide driver, 5.0 mm**      **07942-MA60000 or 07942-8920000**

While the cylinder head is still heated, drive new valve guides into the cylinder head from the camshaft side until the exposed height is specified value.

### TOOL:

**Valve guide driver**      **07942-MA60000 or 07942-8920000**

### VALVE GUIDE PROJECTION:

**IN/EX: 11.8–12.0 mm (0.46–0.47 in)**

Let the cylinder head cool to room temperature.

Ream the new valve guides.

*Take care not to tilt or lean the reamer or lean the reamer in the guide while reaming. Use cutting oil on the reamer during this operation.*

Insert the reamer from the combustion chamber side of the head and always rotate the reamer clockwise.

### TOOL:

**Valve guide reamer, 5.0 mm**      **07984-MA60001 or 07984-MA6000D**

Clean the cylinder head thoroughly to remove any metal particles after reaming and refacing the valve seat (page 8-19).

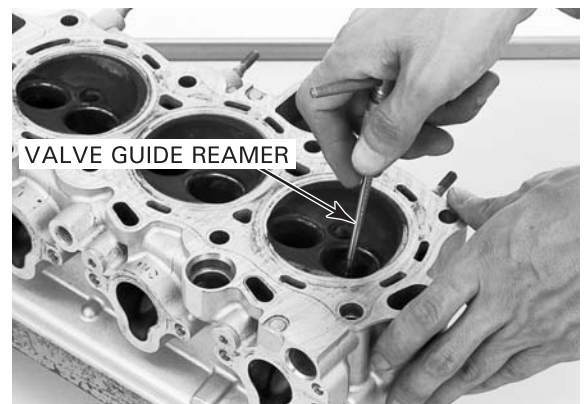
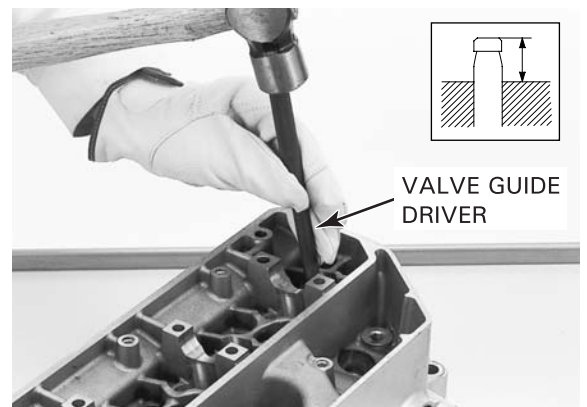
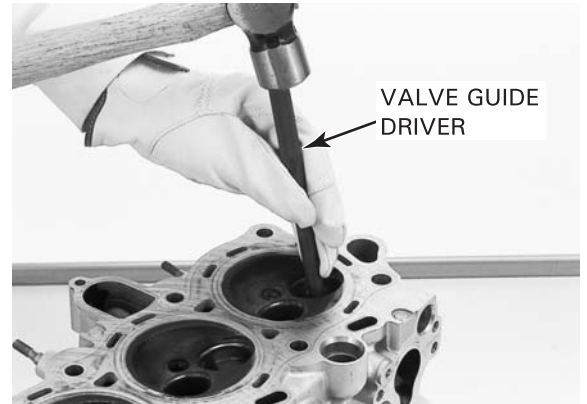

## VALVE SEAT INSPECTION/REFACING

### INSPECTION

Clean all intake and exhaust valves thoroughly to remove carbon deposits.

Apply a light coat of Prussian Blue to each valve seat.

Tap the valve against the valve seat several times without rotating the valve, to check for proper valve seat contact.





## CYLINDER HEAD/VALVE

The valve cannot be ground. If the valve face is burned or badly worn or if it contacts the seat unevenly, replace the valve.

Remove the valve and inspect the valve seat face. The valve seat contact should be within the specified width and even all around the circumference.

**STANDARD: 0.9 – 1.1 mm (0.035 – 0.043 in)**  
**SERVICE LIMIT: 1.5 mm (0.06 in)**

If the valve seat width is not within specification, reface the valve seat.

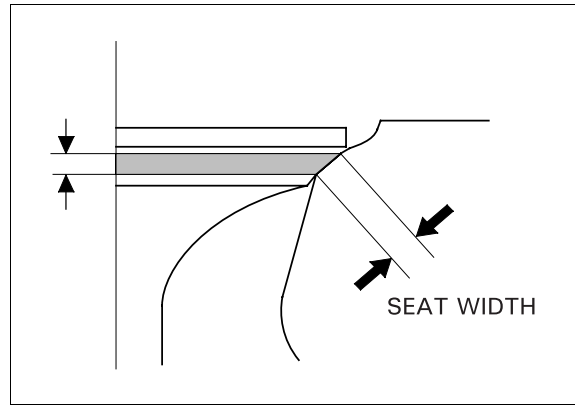

Inspect the valve seat face for:

- Damaged face:
  - Replace the valve and reface the valve seat.
- Uneven seat width:
  - Replace the valve and reface the valve seat.

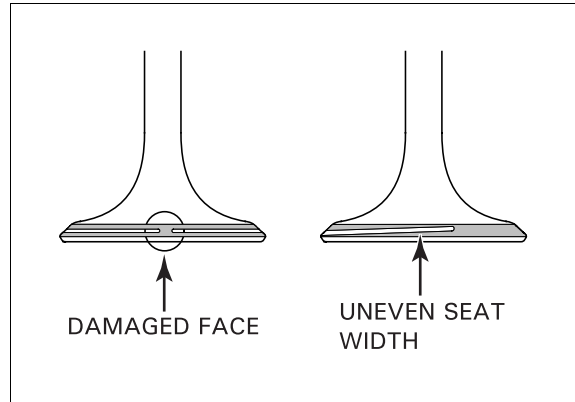

- Contact area (too low or too high)
  - Reface the valve seat.

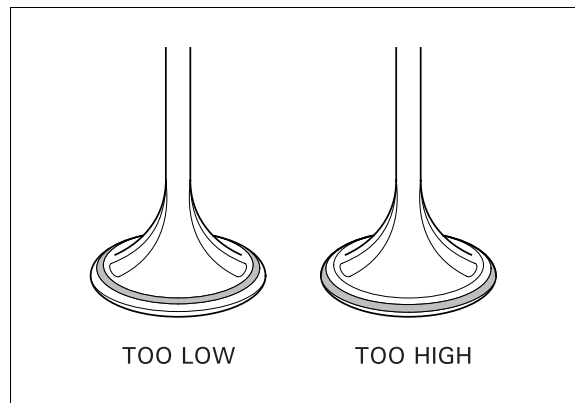

## REFACING

NOTE:

- Follow the refacer manufacturer's operating instructions.
- Be careful not to grind the seat more than necessary.

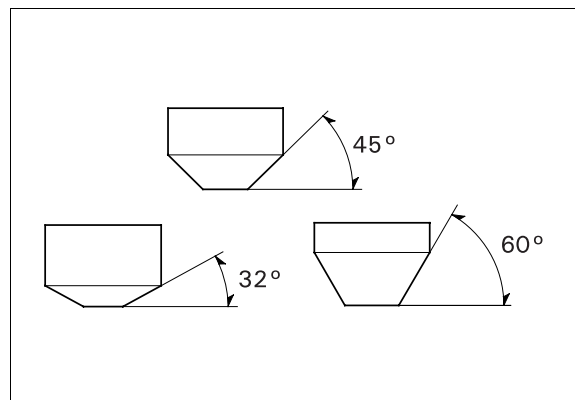

If the contact area is too high on the valve, the seat must be lowered using a 32° flat cutter.  
 If the contact area is too low on the valve, the seat must be raised using a 60° interior cutter.

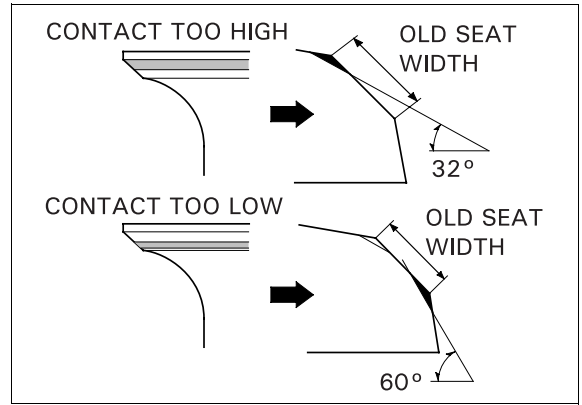

Using a 45° seat cutter, remove any roughness or irregularities from the seat.

- TOOLS:**  
 Valve seat cutter, 33 mm (IN) 07780-0010800  
 Valve seat cutter, 29 mm (EX) 07780-0010300  
 Cutter holder, 5.0 mm 07781-0010400

or equivalent commercially available in U.S.A.

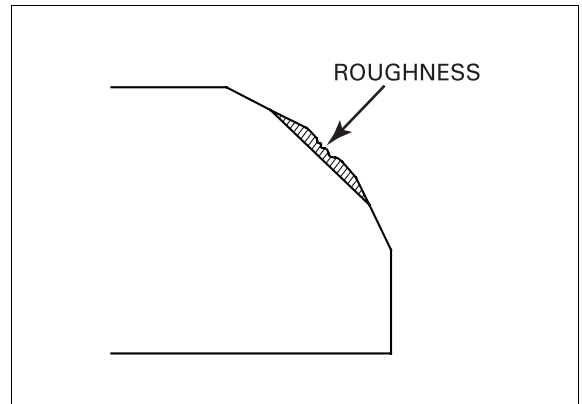

Using a 32° flat cutter, remove 1/4 of the existing valve seat material.

- TOOLS:**  
 Flat cutter, 35 mm (IN) 07780-0012300  
 Flat cutter, 33 mm (EX) 07780-0012900  
 Cutter holder, 5.0 mm 07781-0010400

or equivalent commercially available in U.S.A.

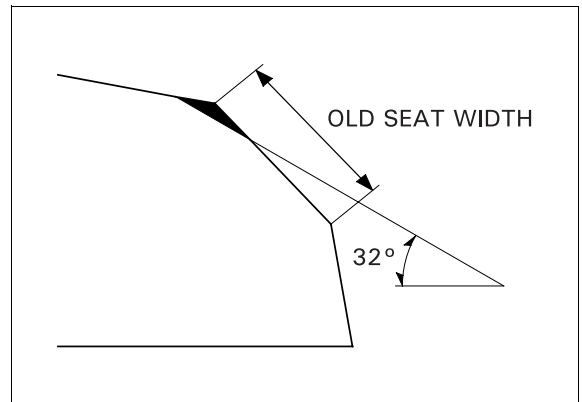

Using a 60° interior cutter, remove 1/4 of the existing valve seat material.

- TOOLS:**  
 Interior cutter, 30 mm (IN/EX) 07780-0014000  
 Cutter holder, 5.0 mm 07781-0010400

or equivalent commercially available in U.S.A.

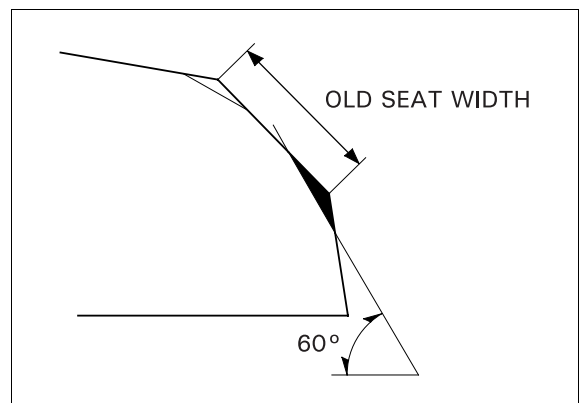

## CYLINDER HEAD/VALVE

Using a 45° seat cutter, cut the seat to the proper width.

Make sure all pitting and irregularities are removed.

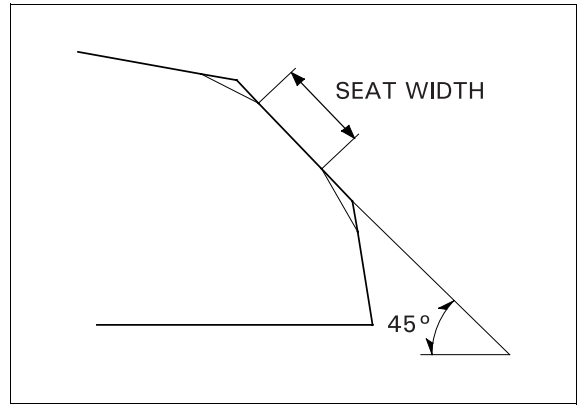

*Excessive lapping pressure may deform or damage the seat. Do not allow lapping compound to enter the guides.*

After cutting the seat, apply lapping compound to the valve face, and lap the valve using light pressure.

Change the angle of the lapping tool frequently to prevent uneven seat wear.

After lapping, wash any residual compound off the cylinder head and valve and recheck the seat contact.

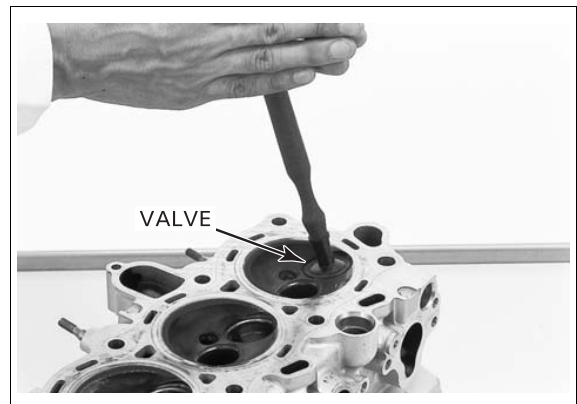

## CYLINDER HEAD ASSEMBLY

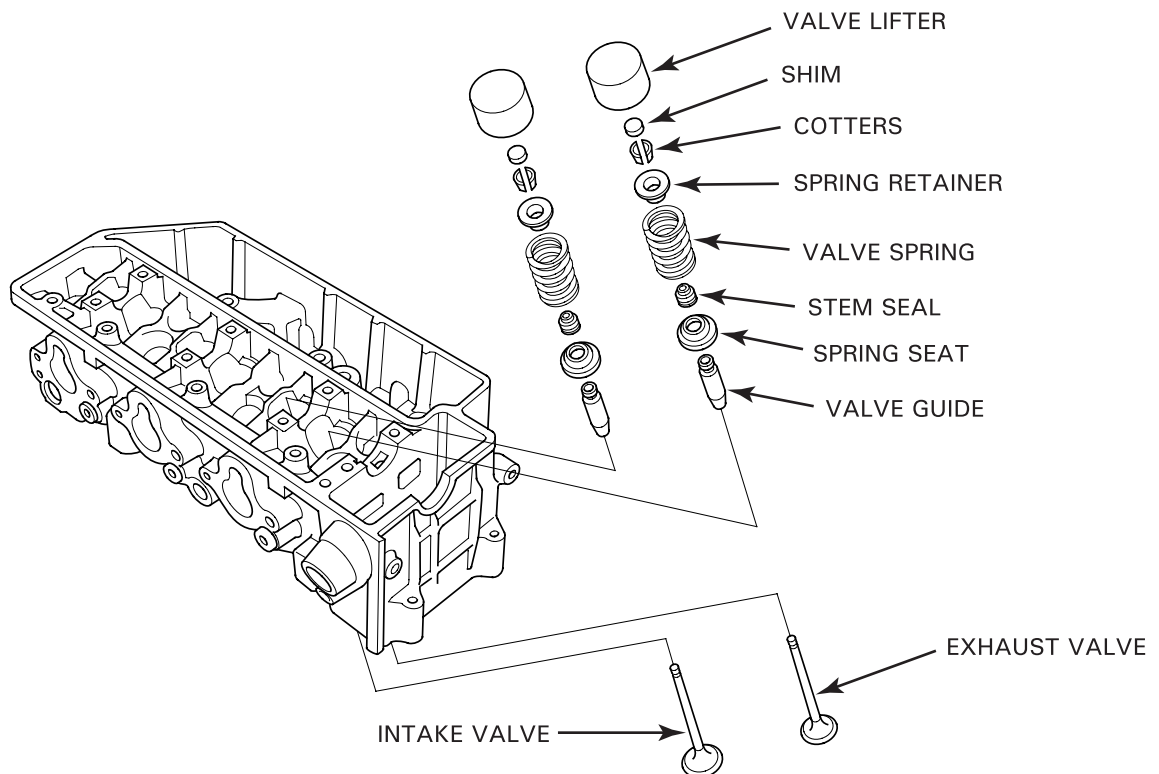

Blow out all oil passages in the cylinder head with compressed air.  
 Install the valve spring seats.  
 Install new stem seals.

Lubricate the valve stem sliding surface with molybdenum oil solution.  
 Insert the valve into the guide while turning it slowly to avoid damaging the stem seal.

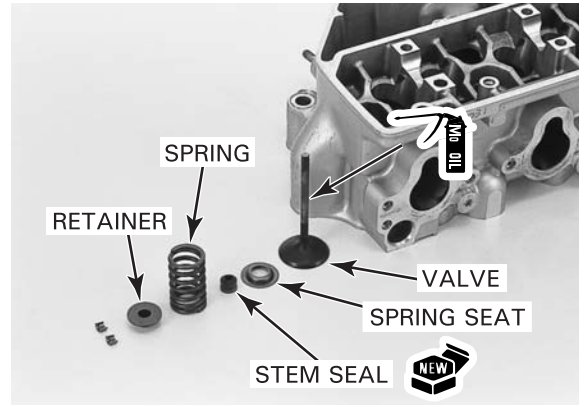

Install the valve springs with the tightly wound coils facing the combustion chamber.  
 Install the spring retainer.

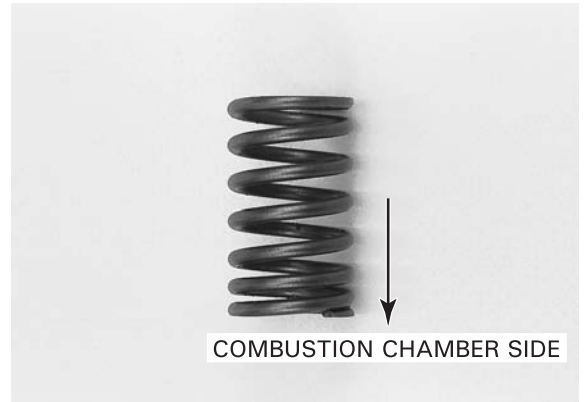

Install the lifter bore protector made from a film container into the valve lifter bore.



*Grease the cotters to ease installation.  
 To prevent loss of tension, do not compress the valve springs more than necessary to install the cotters.*

Install the valve spring cotters using the valve spring compressor.

**TOOL:**  
**Valve spring compressor**      **07757-0010000**

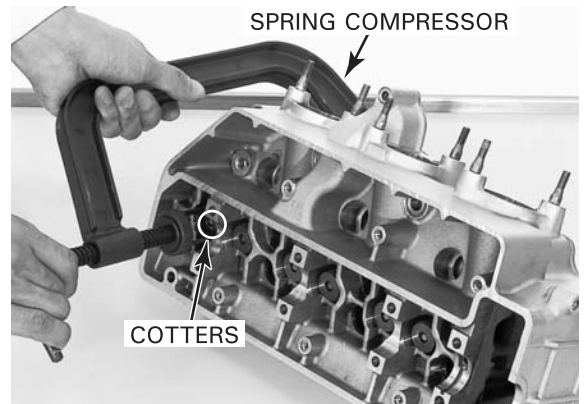

## CYLINDER HEAD/VALVE

Support the cylinder head so the valve heads will not contact anything and possibly get damaged. Tap the valve stems gently with two plastic hammers to seat the cotters firmly as shown.



## CYLINDER HEAD INSTALLATION

Clean the gasket mating surfaces of the crankcase, manifold and cylinder head thoroughly, being careful not to damage them.

Set support blocks between the crankcase and intake manifold to prevent interference the cylinder head with the manifold.

Install the two dowel pins and a new gasket. Coat a new O-ring with coolant and install it onto the water joint pipe.

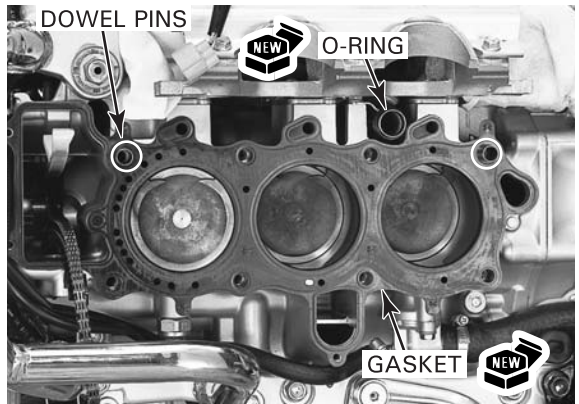

Install the cylinder head while connecting the joint pipe.

Apply engine oil to the threads and seating surfaces of the 9-mm cylinder head bolts.

Install the eight 9-mm bolts and three 6-mm bolts, and tighten them in a crisscross pattern in several steps.

**TORQUE: 9 mm bolts: 44 N·m (4.5 kgf·m, 33 lbf·ft)**

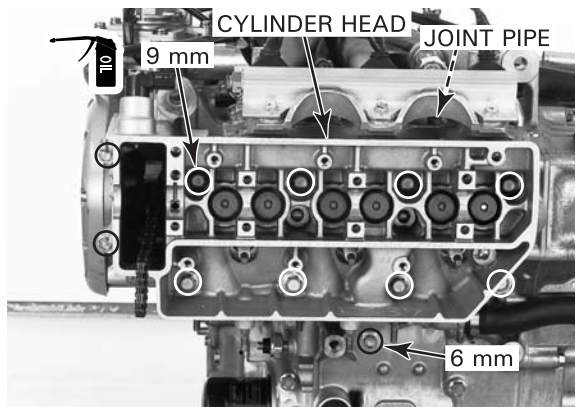

*Left cylinder head only:* Install the ECT sensor with a new sealing washer.

**TORQUE: 25 N·m (2.5 kgf·m, 18 lbf·ft)**

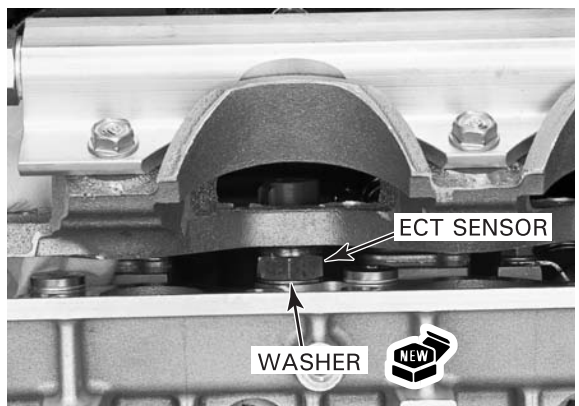



## CYLINDER HEAD/VALVE

Install new manifold gaskets onto the left and right cylinder heads, and align the bolt holes in the cylinder head and gasket.

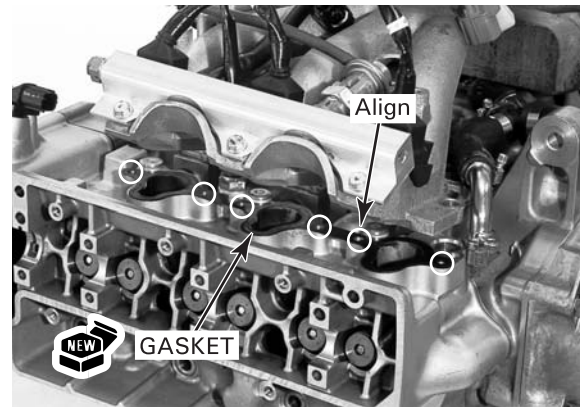

Carefully remove the support blocks and place the manifold assembly onto the cylinder heads.

Be sure to align the bolt holes in the manifold and gaskets, and install the twelve bolts. Tighten the bolts in a crisscross pattern in several steps.

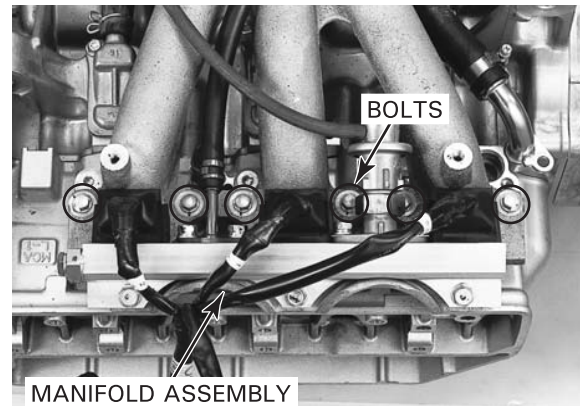

Coat a new O-ring with coolant and install it onto the water hose joint pipe. Install the joint pipe into the cylinder head and tighten the bolt.

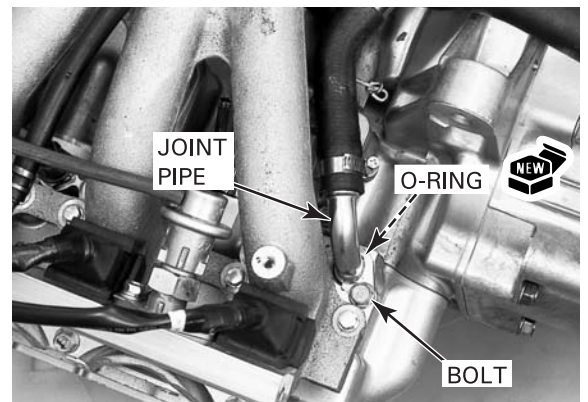

*Left cylinder head only:* Coat a new O-ring with engine oil and install it into the groove in the camshaft position sensor. Install the camshaft position sensor and tighten the bolt. Connect the 2P connector. Connect the ECT sensor 3P connector.

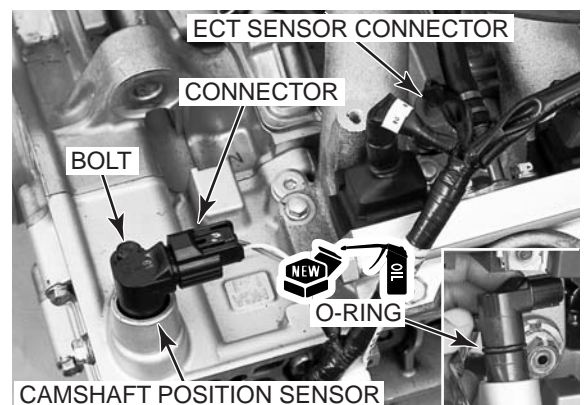

## CYLINDER HEAD/VALVE

*Route the wires and hose properly (page 1-23).*

Install the guide and tighten the two bolts.

If the spark plugs were removed, install the spark plugs and tighten them.

**TORQUE: 18 N·m (1.8 kgf·m, 13 lbf·ft)**

*The cylinder numbers are printed on each spark plug wire.*

Connect the spark plug caps.

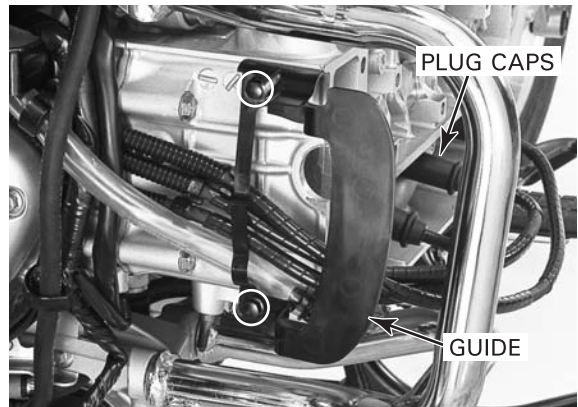

*Route the wires properly (page 1-23).*

Install the left and right radiator stays with the flange bolts.

Install the left and right fuel rail covers with the socket bolts.

Install the following:

- left and right radiators (page 6-8)
- air cleaner housing (page 5-57)
- exhaust pipe (page 2-18)
- camshaft(s) (page 8-28)



## CAM CHAIN INSTALLATION

Install the following:

- key
- timing sprocket (align the groove with the key)

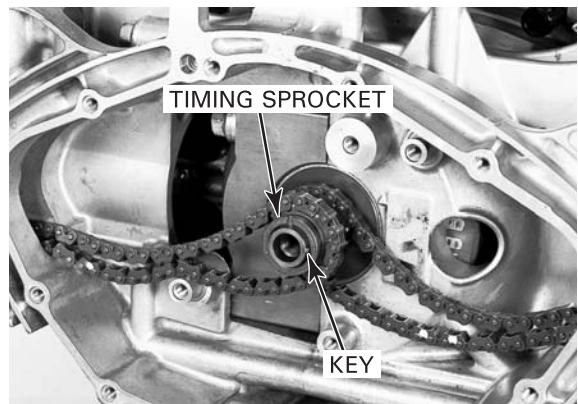

- cam chains
- cam chain guides
- left chain guide washer bolt

**TORQUE: 12 N·m (1.2 kgf·m, 9 lbf·ft)**

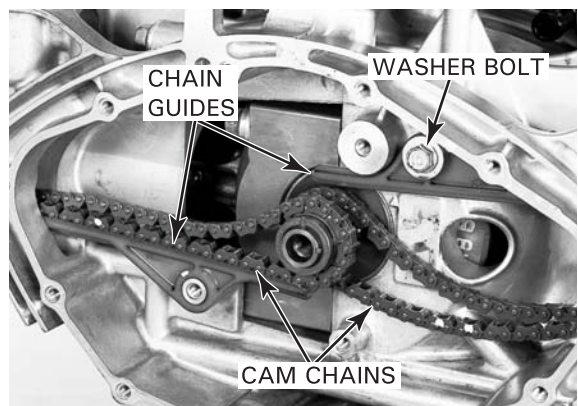



## CYLINDER HEAD/VALVE

- left cam chain tensioner with two bolts
- right cam chain tensioner with washer (between crankcase and tensioner), pivot collar and bolt

**TORQUE: 12 N·m (1.2 kgf·m, 9 lbf·ft)**

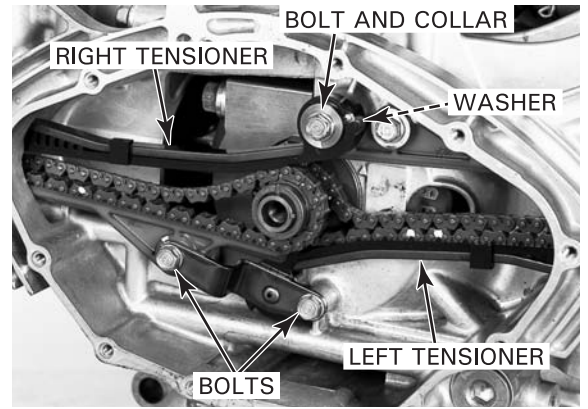

- ignition pulse generator rotor (align the groove with the key)
- washer and bolt (apply engine oil to the threads and seating surface)

**TORQUE: 59 N·m (6.0 kgf·m, 43 lbf·ft)**

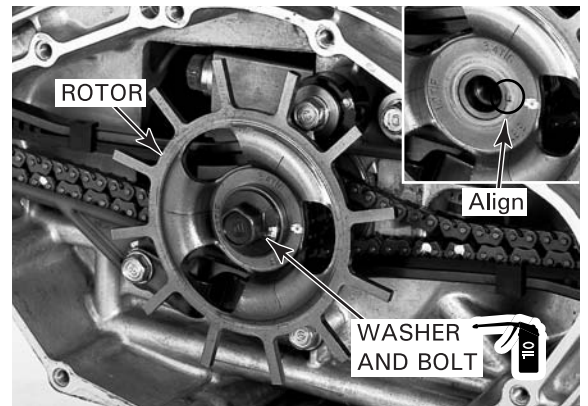

Clean the gasket mating surfaces of the crankcase and cover thoroughly, being careful not to damage them.

Install the following onto the crankcase cover:

- ignition pulse generator
- two bolts with retainer (apply locking agent to the threads)

**TORQUE: 12 N·m (1.2 kgf·m, 9 lbf·ft)**

- grommet

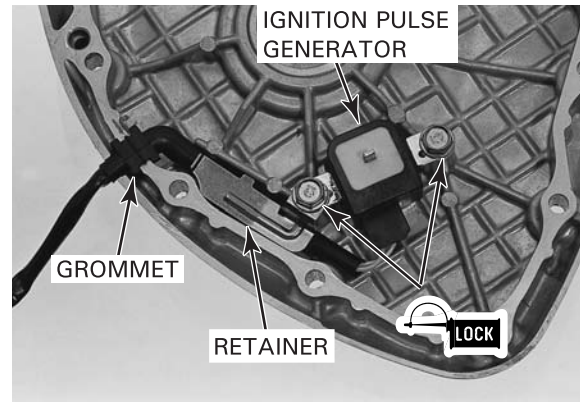

Apply liquid sealant to the mating areas of the crankcase as shown.

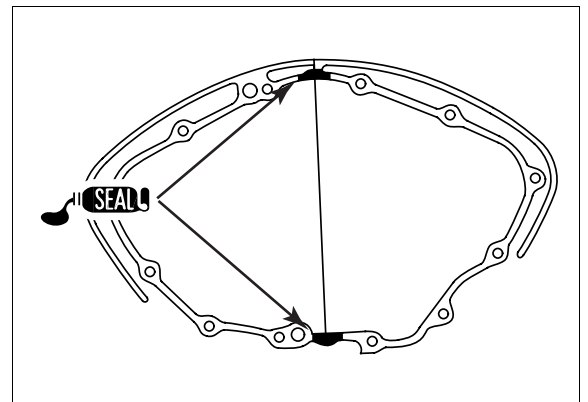

## CYLINDER HEAD/VALVE

Install the following:

- two dowel pins
- new gasket

- front crankcase cover
- twelve bolts

**TORQUE: 12 N·m (1.2 kgf·m, 9 lbf·ft)**

Install the camshafts (page 8-28).

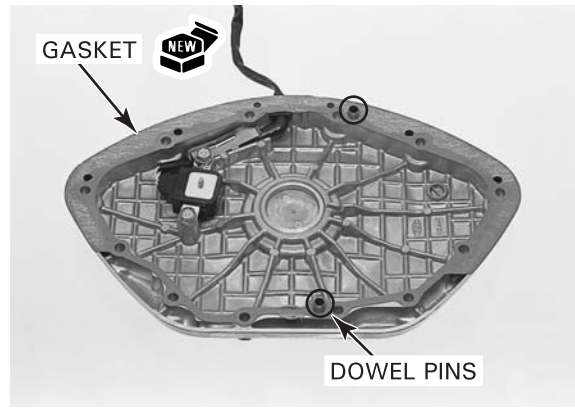

## CAMSHAFT INSTALLATION

NOTE:

- When either is serviced, the other cylinder head cover must be removed and the other camshaft position must be checked.

Install the valve shims in their original locations.

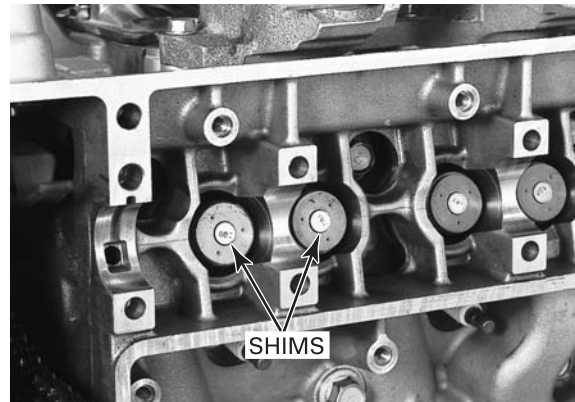

Coat the outer surfaces of the valve lifters with molybdenum oil solution. Install the valve lifters in their original lifter bores, being careful not to damage the sliding surfaces of the lifters and bores.

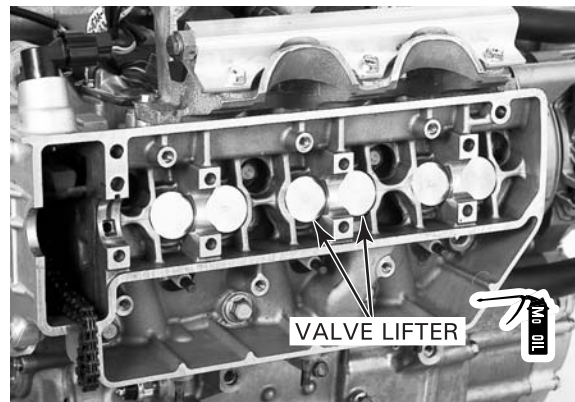

The camshafts have the following identification marks:  
 L: left cylinder camshaft (installed cam pulse rotor)  
 R: right cylinder camshaft

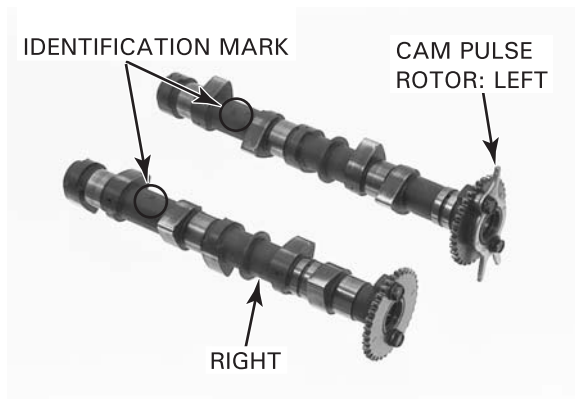

*Be careful not to jam the cam chain and timing sprocket on the crankshaft when rotating the crankshaft.*

Rotate the crankshaft counterclockwise and align the 1.2 TF mark on the ignition pulse generator rotor with the index mark in the front crankcase cover.

If the other camshaft has not been serviced, remove its cylinder head cover and check the camshaft position as shown in the next step.

**NOTE:**

- If the crankshaft has not been rotated since the camshaft was removed, it should not be necessary to rotate it (i.e., it should still be in the proper position). However, check the other camshaft's position as described in the next step, to ensure proper camshaft positioning. Then, install the camshaft.

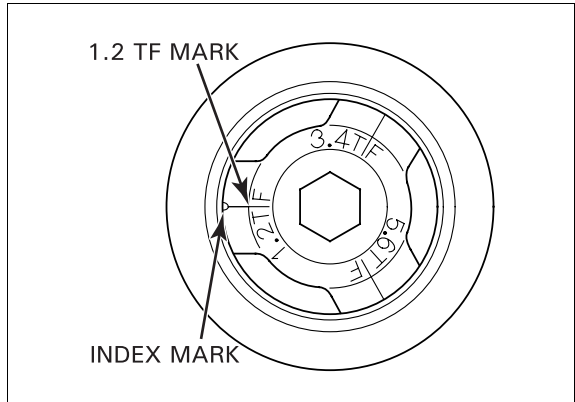

The timing marks on the cam sprocket must be flush with the cylinder head surface and make sure that the index mark "M" is facing out as shown (rear end cam lobe is facing inward).

If the "M" mark is facing in (cannot be seen), rotate the crankshaft counterclockwise 360° (one full turn) and turn the "M" mark so it faces out.

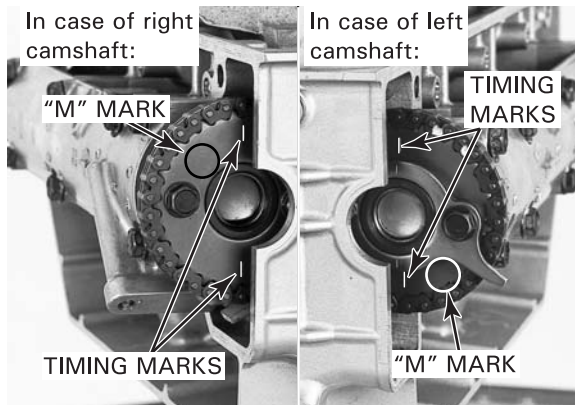

## CYLINDER HEAD/VALVE

Apply molybdenum oil solution to the camshaft journals, thrust surfaces and cam lobes.

*Be careful not to damage the cylinder head and camshaft.*

Install the camshaft while installing the cam chain onto the cam sprocket in its proper location so that the timing marks on the sprocket are flush with the cylinder head surface. Make sure the "M" mark is facing in and the rear end cam lobe is facing out.

Left camshaft shown:

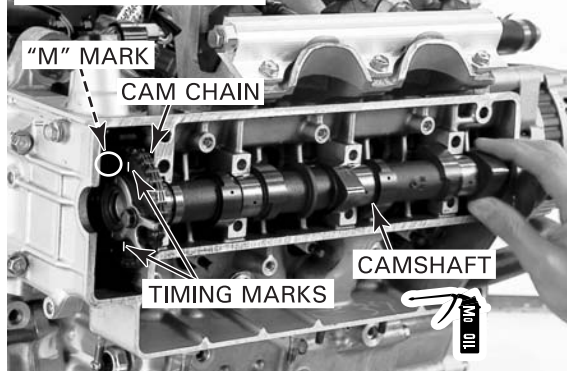

Right camshaft shown:

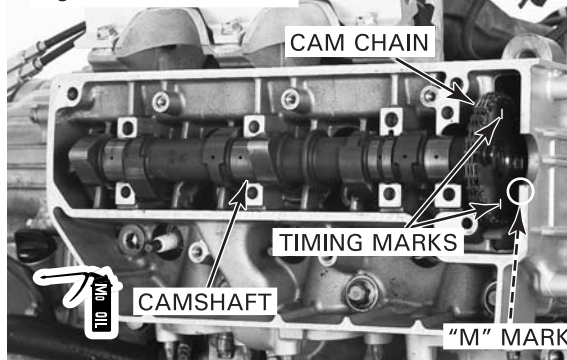

Left camshaft installation:

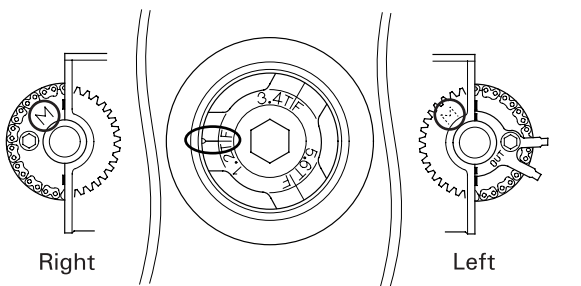

Right camshaft installation:

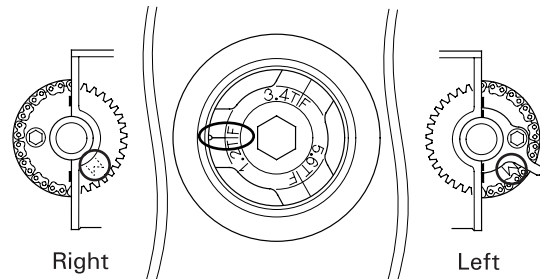

Make sure the guide rails of the cam chain tensioner and guide are positioned over the cam chain properly.

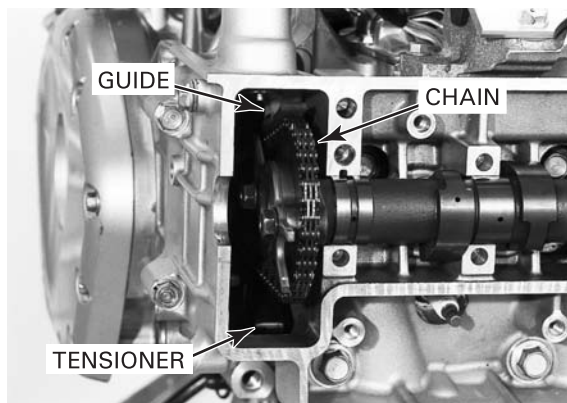



Install the dowel pins and camshaft holder. Apply oil to the threads and seating surfaces of the camshaft holder bolts and install them.

Tighten the holder bolts in several steps according to the numerical order cast on the camshaft holder (1 thru 8).

**TORQUE: 12 N·m (1.2 kgf·m, 9 lbf·ft)**

The remaining camshaft installation is the same as the procedures described on page 8-28.

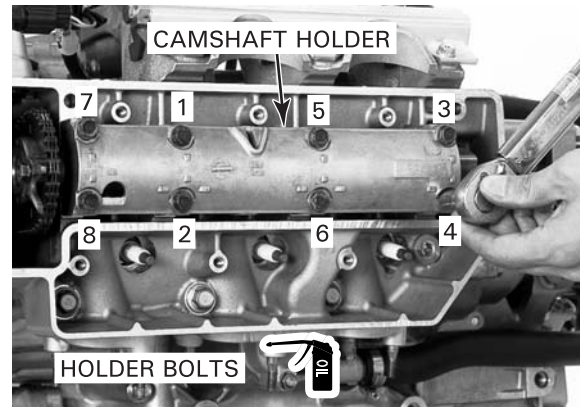

Remove the stopper tool from the tensioner lifter. Install the sealing bolt with the a new sealing washer and tighten it.

**TORQUE: 12 N·m (1.2 kgf·m, 9 lbf·ft)**

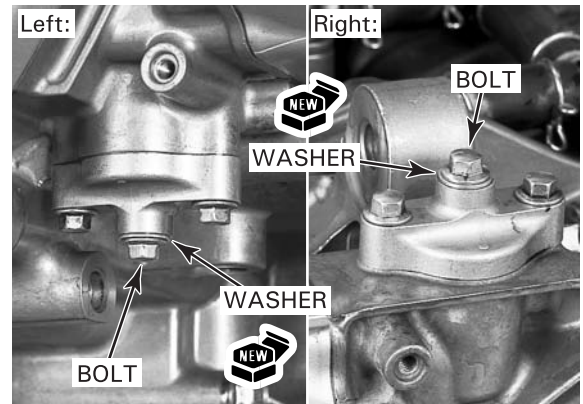

Make sure the timing marks on each cam sprocket are flush with the cylinder head surface when the 1.2 TF mark on the ignition pulse generator rotor is aligned with the index mark in the front crankcase cover.

Apply grease to the timing hole cap threads and coat a new O-ring with engine oil. Install the timing hole cap with the O-ring and tighten it.

**TORQUE: 18 N·m (1.8 kgf·m, 13 lbf·ft)**

Install the cylinder head cover(s) (page 8-32).

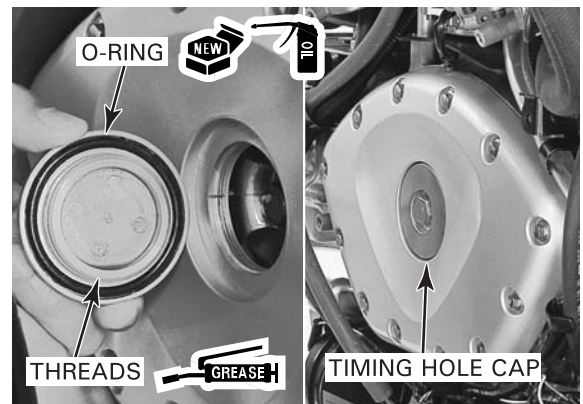

Install the following:

- left horn with bolt
- horn connectors
- front lower fairing if left camshaft was removed (page 2-6)
- right inner fairing if right camshaft was removed (page 2-10)
- center inner fairing (page 2-6)

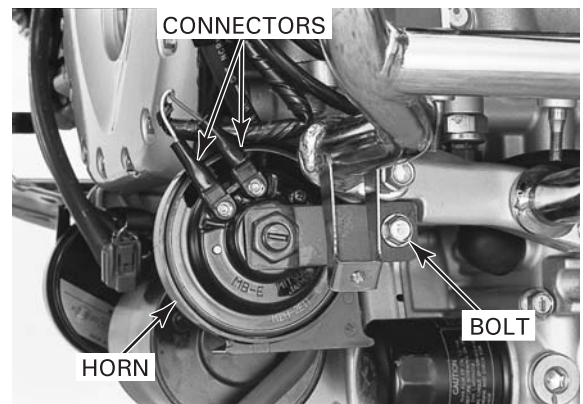

## CYLINDER HEAD/VALVE

# CYLINDER HEAD COVER INSTALLATION

Clean the gasket mating surfaces of the cylinder head and cover thoroughly, being careful not to damage them.

Install a new gasket into the groove in the cylinder head cover.

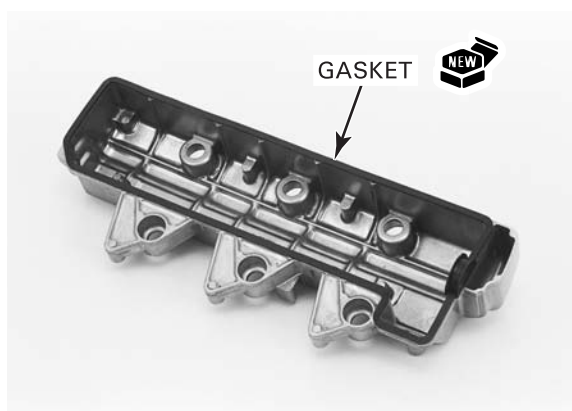

Install the special washers onto the head cover bolts with the "UP" mark facing the bolt head.

Apply sealant to the semi-circular edges of the cylinder head as shown.

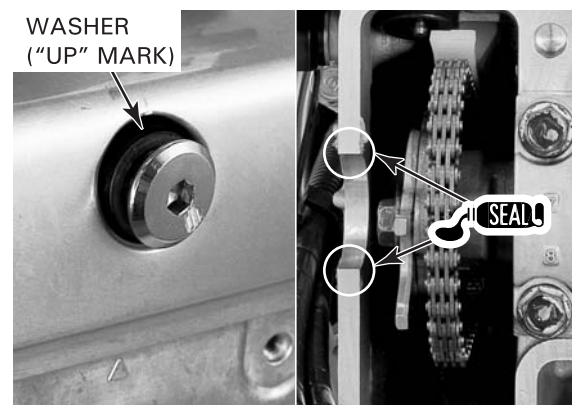

*Be careful not to damage the semi-circular area of the gasket.*

Install the head cover by aligning the semi-circular areas of the cylinder head and gasket properly, then install the cover bolts (left side: six bolts, right side: five bolts) by aligning them with the bolt holes in the cylinder head.

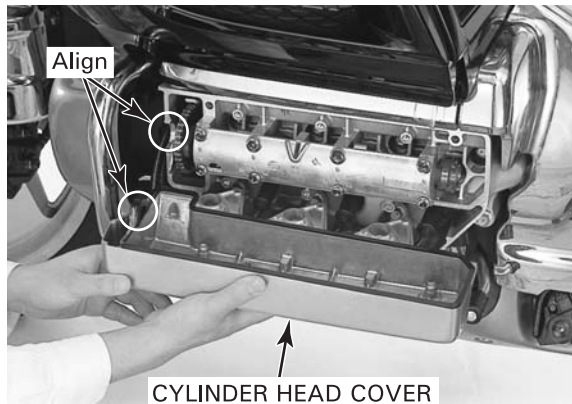

Tighten the head cover bolts in a crisscross pattern in several steps.

**TORQUE: 12 N·m (1.2 kgf·m, 9 lbf·ft)**

Install the three rubber plugs.

Install the wire clip and the clamp with the bolt.

*Route the plug wires properly (page 1-23).*

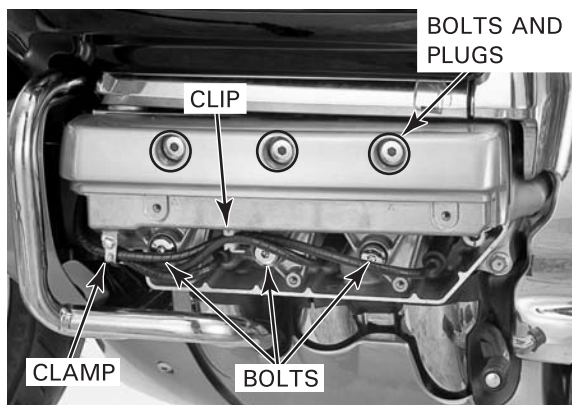

Install the cylinder head side cover and tighten the five bolts.

**TORQUE: 10 N·m (1.0 kgf·m, 7 lbf·ft)**

Install the five rubber plugs.

Fill and bleed the cooling system if the cylinder head was removed (page 6-6).





---

**MEMO**

---

COMPONENT LOCATION .....	9-2	CLUTCH MASTER CYLINDER.....	9-8
SERVICE INFORMATION .....	9-4	CLUTCH SLAVE CYLINDER.....	9-12
TROUBLESHOOTING .....	9-6	CLUTCH.....	9-14
CLUTCH FLUID REPLACEMENT/AIR BLEEDING .....	9-7		

# CLUTCH

## COMPONENT LOCATION

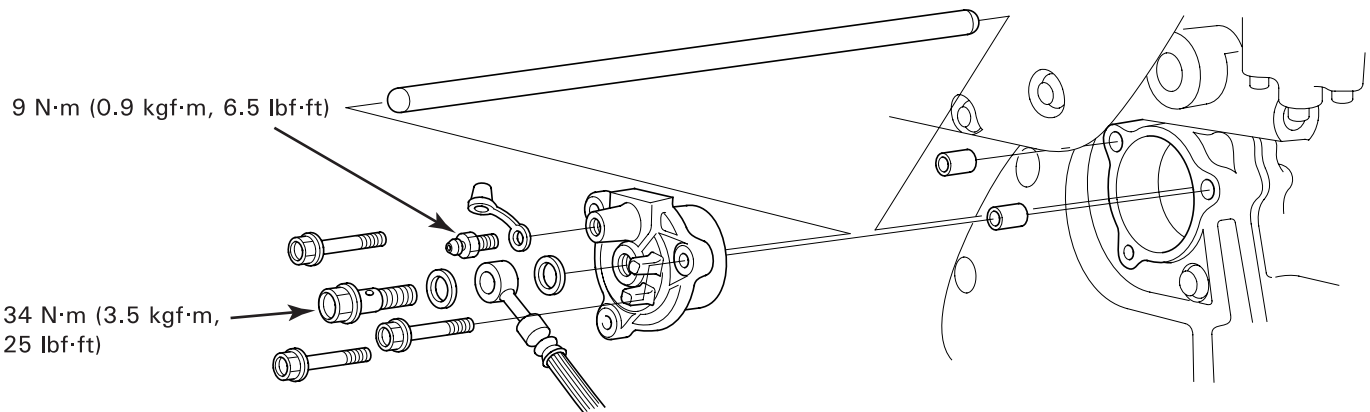
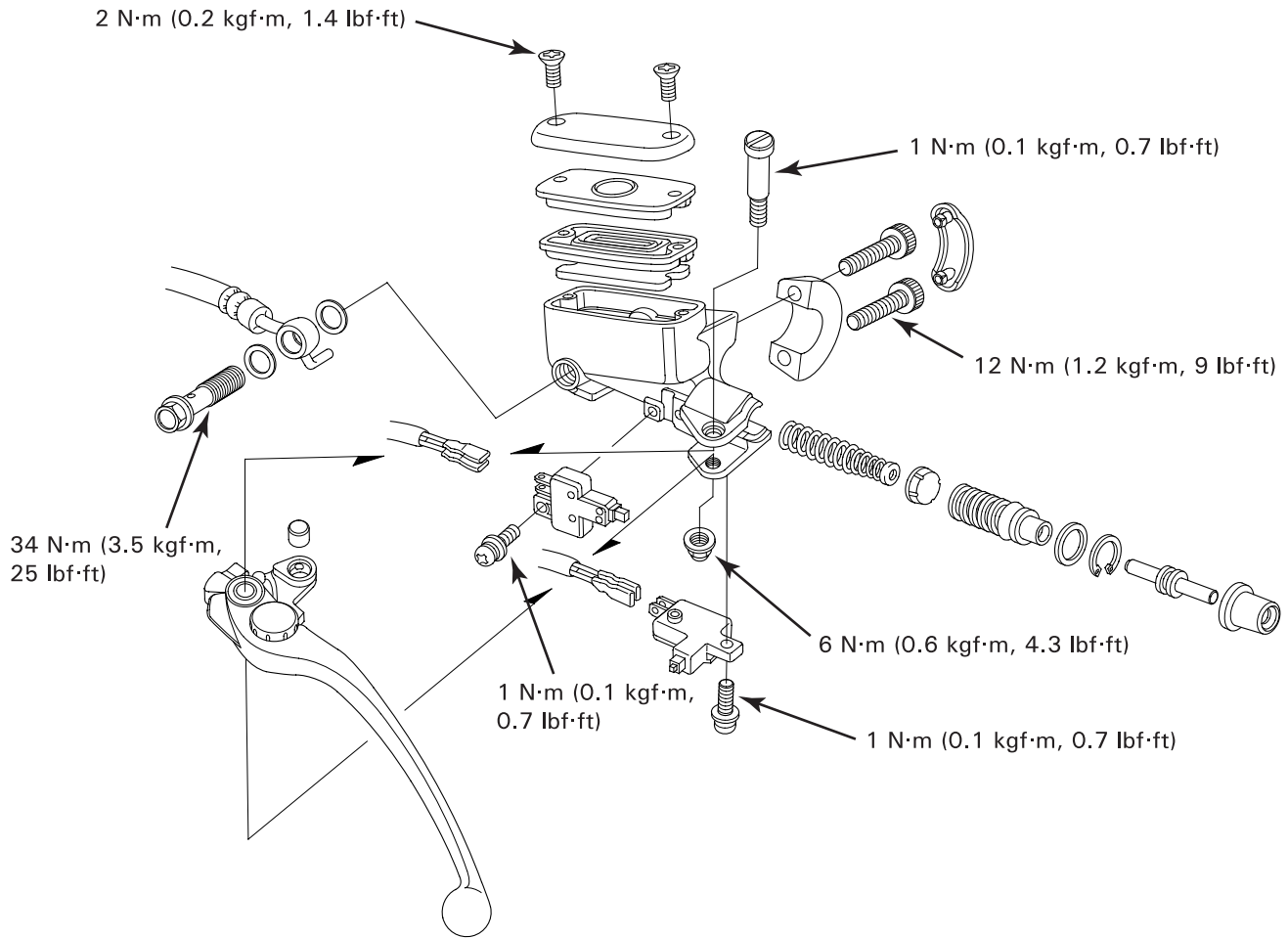

186 N·m (19.0 kgf·m, 137 lbf·ft)

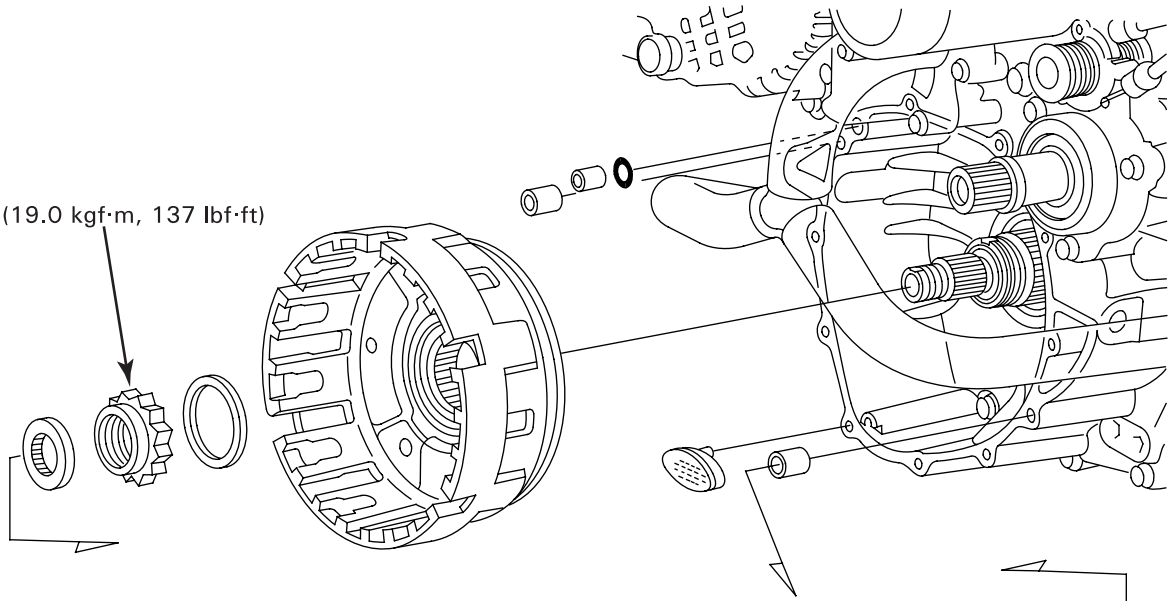

127 N·m (13.0 kgf·m, 94 lbf·ft)

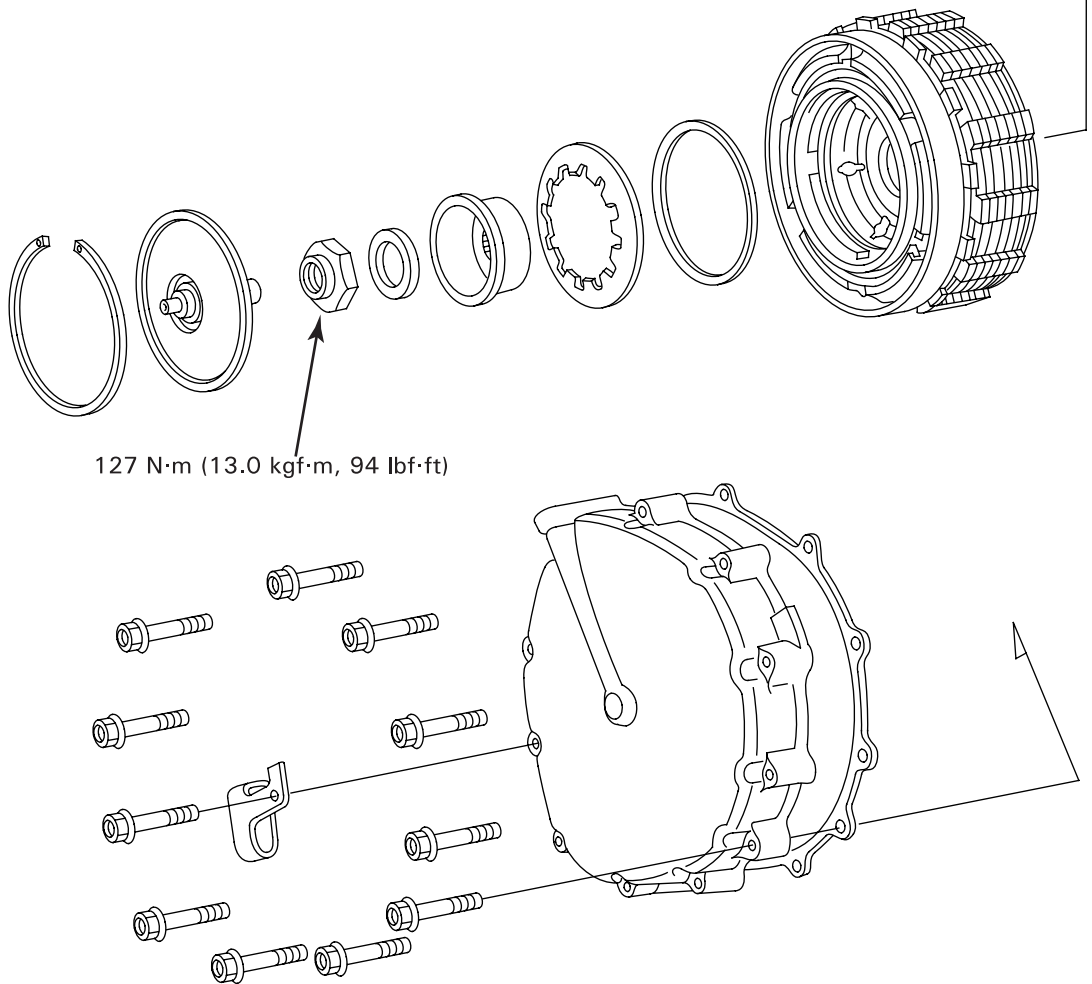

## CLUTCH

# SERVICE INFORMATION

### GENERAL

- The clutch system can be serviced with the engine installed in the frame
- DOT 4 brake fluid is used for the hydraulic clutch and is referred to as clutch fluid in this section. Do not use other types of fluid as they are not compatible.
- Spilled clutch (brake) fluid will severely damage the plastic parts and painted surfaces. It is also harmful to some rubber parts. Be careful whenever you remove the reservoir cap; make sure the reservoir is horizontal first.
- Never allow contaminants (e.g. dirt, water) to get into an open reservoir.
- Once the hydraulic system has been opened, the system must be bled.
- Always use fresh DOT 4 brake fluid from a sealed container when servicing the system. Do not mix different types of fluid as they may not be compatible.
- Engine oil viscosity and level and the use of oil additives have an effect on clutch disengagement. Oil additives of any kind are specifically not recommended. When the clutch does not disengage or the motorcycle creeps with the clutch disengaged, inspect the engine oil viscosity and level before servicing the clutch system.

### SPECIFICATIONS





Unit: mm (in)

ITEM		STANDARD	SERVICE LIMIT
Specified clutch fluid		DOT 4 brake fluid	–
Clutch master cylinder	Cylinder I.D.	14.000 – 14.043 (0.5512 – 0.5529)	14.055 (0.5533)
	Piston O.D.	13.957 – 13.984 (0.5495 – 0.5506)	13.945 (0.5490)
Clutch	Clutch spring free height	4.8 (0.19)	4.6 (0.18)
	Clutch lifter spring free height	2.9 (0.11)	2.5 (0.10)
	Disc thickness	3.72 – 3.88 (0.146 – 0.153)	3.5 (0.14)
	Plate warpage	–	0.30 (0.012)

### TORQUE VALUES

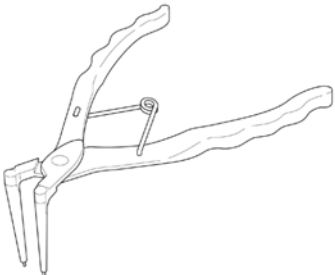
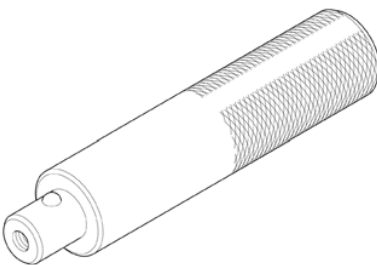
Clutch master cylinder reservoir cap screw	2 N·m (0.2 kgf·m, 1.4 lbf·ft)	
Clutch slave cylinder bleed valve	9 N·m (0.9 kgf·m, 6.5 lbf·ft)	
Clutch lever pivot bolt	1 N·m (0.1 kgf·m, 0.7 lbf·ft)	
Clutch lever pivot nut	6 N·m (0.6 kgf·m, 4.3 lbf·ft)	
Clutch switch screw	1 N·m (0.1 kgf·m, 0.7 lbf·ft)	
Clutch cruise switch screw	1 N·m (0.1 kgf·m, 0.7 lbf·ft)	
Clutch master cylinder holder bolt	12 N·m (1.2 kgf·m, 9 lbf·ft)	
Clutch hose oil bolt	34 N·m (3.5 kgf·m, 25 lbf·ft)	
Clutch outer lock nut	186 N·m (19.0 kgf·m, 137 lbf·ft)	Apply locking agent to the threads and stake the nut.
Clutch center lock nut	127 N·m (13.0 kgf·m, 94 lbf·ft)	Apply engine oil to the threads and seating surface and stake the nut.

**TOOLS**

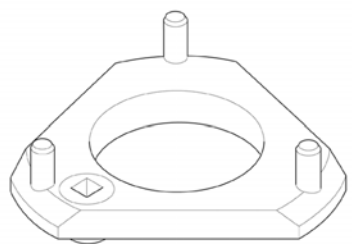
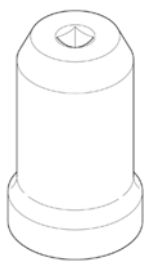
<p>Snap ring pliers 07914-SA50001</p> 	<p>Driver 07749-0010000</p> 	<p>Attachment, 32 x 35 mm 07746-0010100</p> 
<p>Pilot, 17 mm 07746-0040400</p> 	<p>Shaft holder 07PAB-0010200</p>  <p>or 07924-PJ40001 (U.S.A. only)</p>	<p>Clutch outer holder 07JMB-MN50100</p> 
<p>Lock nut wrench, 46 mm 07JMA-MN50100</p> 		

## CLUTCH

---

### TROUBLESHOOTING

#### **Clutch lever pressure stiff**

- Sticking piston
- Clogged hydraulic system

#### **Clutch slips**

- Stuck piston
- Clogged hydraulic system
- Discs worn
- Weak clutch spring
- Clutch regulator valve stuck open (section 10)
- Low oil pressure (section 4)

#### **Clutch will not disengage or motorcycle creeps with clutch disengaged**

- Air in hydraulic system
- Low clutch fluid level
- Stuck piston
- Leaking hydraulic system
- Warped plates
- Oil level too high, improper oil viscosity or oil additive used



# CLUTCH FLUID REPLACEMENT/AIR BLEEDING

## CLUTCH FLUID DRAINING

Remove the EVAP canister (page 5-74).

*Do not allow foreign material to enter the system.*

Turn the handlebar to the right until the reservoir is level.

Remove the two screws, reservoir cap, set plate and diaphragm.

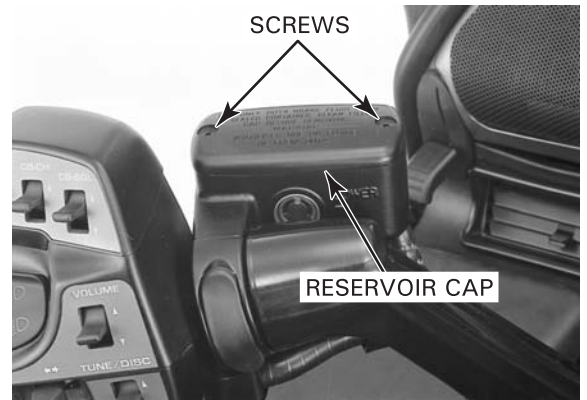

Connect a bleed hose to the bleed valve of the clutch slave cylinder.

Loosen the bleed valve and pump the clutch lever until fluid stops flowing out of the bleed valve.

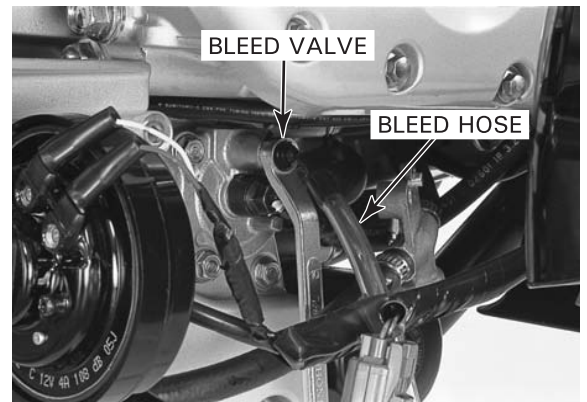

## CLUTCH FLUID FILLING/BLEEDING

Close the bleed valve.

*Use only DOT 4 brake fluid from a sealed container.*

Fill the reservoir with DOT 4 brake fluid from a sealed container.

*Do not mix different types of fluid, they are not compatible.*

Connect a commercially available brake bleeder to the bleed valve.

Pump the brake bleeder and loosen the bleed valve. Add brake fluid when the fluid level in the reservoir is low.

### NOTE:

- Check the fluid level often while bleeding the clutch to prevent air from being pumped into the system.
- When using a brake bleeding tool, follow the manufacturer's operating instructions.

Repeat the above procedures until new fluid flows out of the bleed valve and air bubbles do not appear in the plastic hose.

### NOTE:

- If air is entering the bleeder from around the bleed valve threads, seal the threads with teflon tape.

Close the bleed valve.



## CLUTCH

If a brake bleeder is not available, use the following procedure:

Pump the clutch lever until lever resistance is felt.

Connect a bleed hose to the bleed valve and bleed the system as follows:

1. Squeeze the clutch lever, open the bleed valve 1/4 of a turn and then close it.

**NOTE:**

- Do not release the clutch lever until the bleed valve has been closed.
2. Release the clutch lever slowly and wait several seconds after it reaches the end of its travel.

Repeat steps 1 and 2 until air bubbles do not appear in the bleed hose.

Tighten the bleed valve.

**TORQUE: 9 N·m (0.9 kgf·m, 6.5 lbf·ft)**

Fill the reservoir to the casting ledge with DOT 4 brake fluid from a sealed container.

Install the diaphragm, set plate and reservoir cap, and tighten the cap screws.

**TORQUE: 2 N·m (0.2 kgf·m, 1.4 lbf·ft)**

Install the EVAP canister (page 5-74).

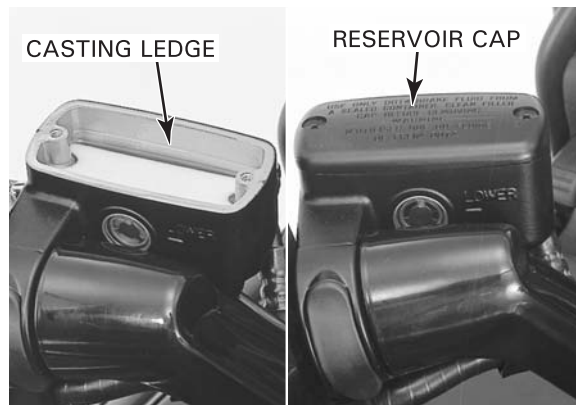
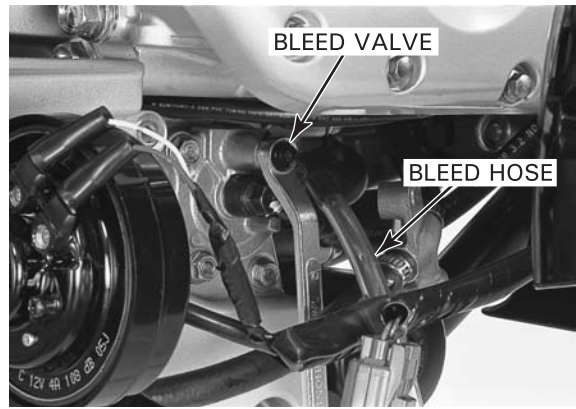

## CLUTCH MASTER CYLINDER

### DISASSEMBLY

Drain the clutch fluid from the hydraulic system (page 9-7).

Disconnect the clutch switch and cruise switch connectors.

Disconnect the clutch hose from the master cylinder by removing the oil bolt and sealing washers.

*When removing the oil bolt, cover the end of the hose to prevent contamination.*

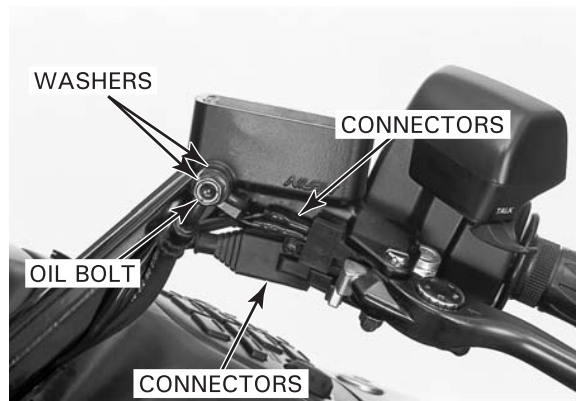

Remove the following:

- holder cap
- holder bolts
- master cylinder holder
- clutch master cylinder

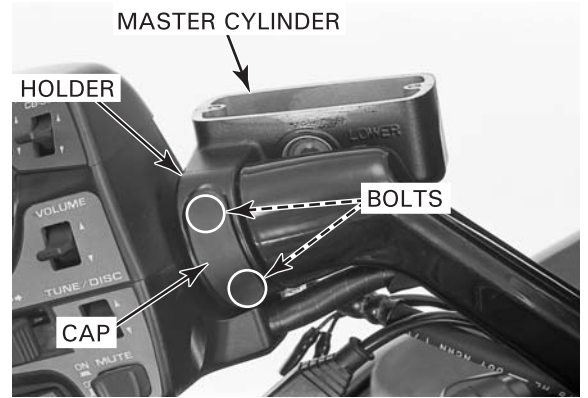

- screw and clutch switch
- screw and cruise switch
- pivot nut
- pivot bolt
- clutch lever

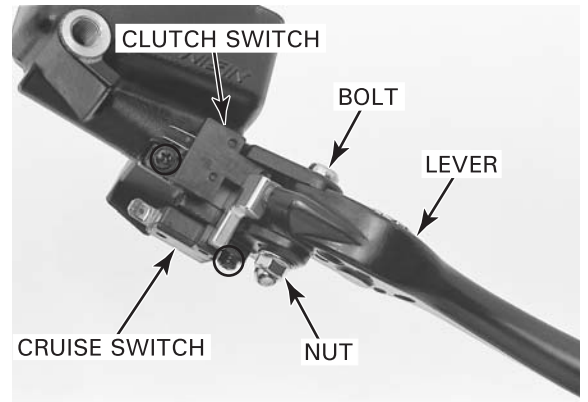

- push rod
- piston boot
- snap ring

**TOOL:**

**Snap ring pliers**

**07914-SA50001**

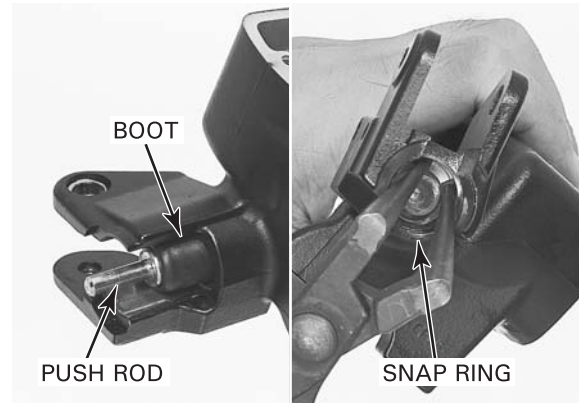

- spring seat
- master piston
- primary cup
- spring

Clean the master cylinder and master piston in clean brake fluid.

**INSPECTION**

Check the piston cups for wear, deterioration or damage.  
Check the spring for damage.

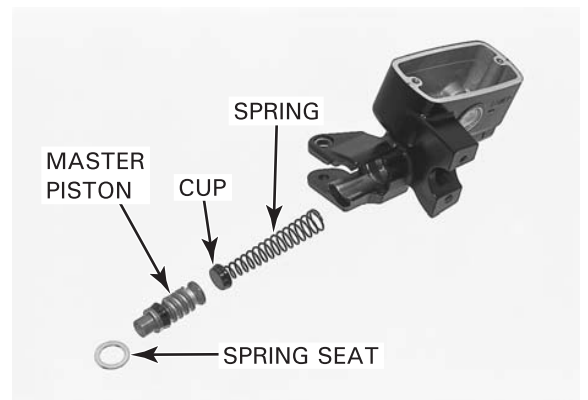

# CLUTCH

Check the master cylinder and piston for scoring, scratches or damage.

Measure the master cylinder I.D.

**SERVICE LIMIT: 14.055 mm (0.5533 in)**

Measure the master piston O.D.

**SERVICE LIMIT: 13.945 mm (0.5490 in)**



## ASSEMBLY

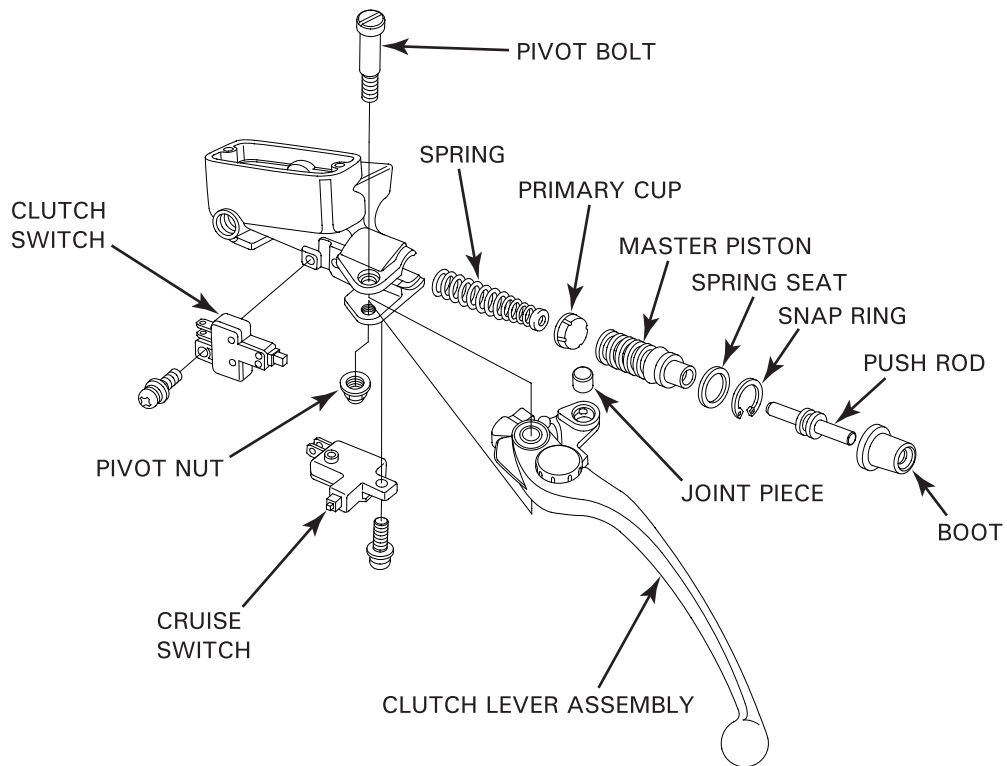

Coat the master piston and piston cups with clean brake fluid.

Install the primary cup onto the spring.

Install the spring, master piston and spring seat into the master cylinder.

*Do not allow the piston cup lips to turn inside out.*

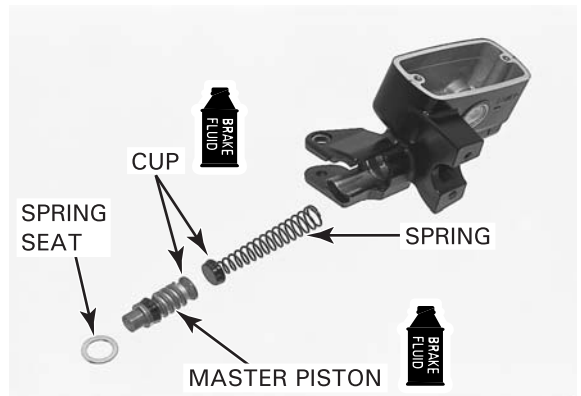

*Make sure the snap ring is firmly seated in the groove.*

Install the snap ring into the groove in the master cylinder using the special tool.

**TOOL:**  
**Snap ring pliers 07914-SA50001**

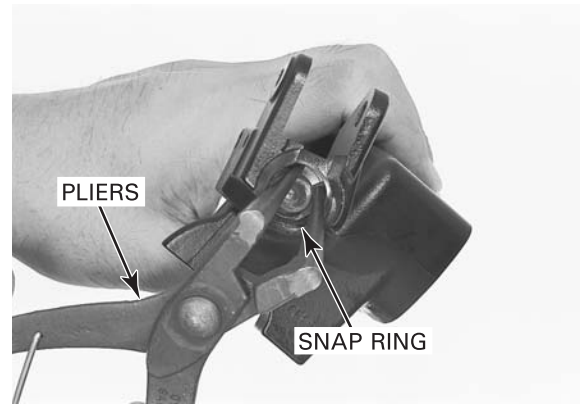

Apply silicone grease to the push rod contacting area of the master piston.  
 Install the boot onto the push rod groove.  
 Install the boot and push rod into the master cylinder.

Apply silicone grease to the push rod hole in the clutch lever joint piece.

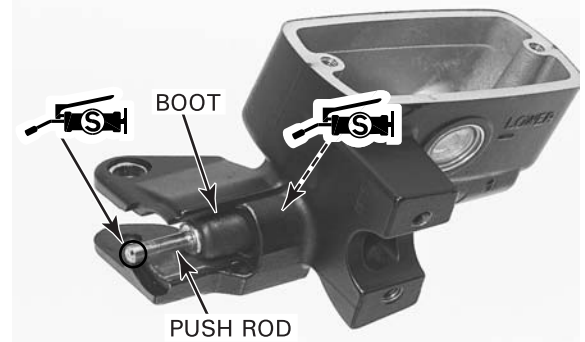

Apply silicone grease to the clutch lever pivot.

Insert the push rod into the hole in the joint piece to install the clutch lever assembly onto the master cylinder.

Install and tighten the pivot bolt.

**TORQUE: 1 N·m (0.1 kgf·m, 0.7 lbf·ft)**

Install and tighten the pivot nut.

**TORQUE: 6 N·m (0.6 kgf·m, 4.3 lbf·ft)**

Install the clutch switch and cruise switch with the screws.

**TORQUE: 1 N·m (0.1 kgf·m, 0.7 lbf·ft)**

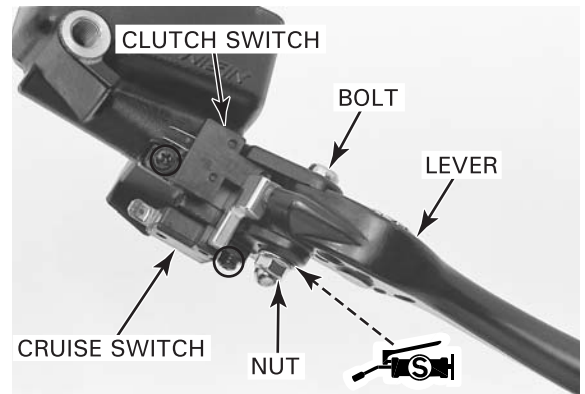

Install the master cylinder and holder by aligning the end of the master cylinder with the punch mark on the handlebar. Tighten the upper bolt first, then tighten the lower bolt.

**TORQUE: 12 N·m (1.2 kgf·m, 9 lbf·ft)**

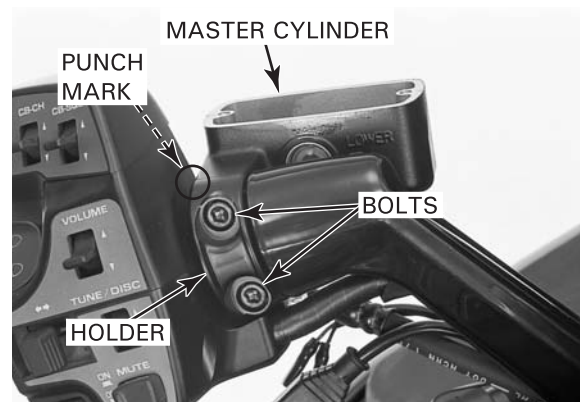



## CLUTCH

Install the holder cap into the holder bolts.



Connect the clutch hose to the master cylinder with the oil bolt and new sealing washers. Be sure to rest the hose joint pin against the stopper and tighten the oil bolt.

**TORQUE: 34 N·m (3.5 kgf·m, 25 lbf·ft)**

Connect the clutch switch and cruise switch connectors.

Fill and bleed the clutch hydraulic system (page 9-7).

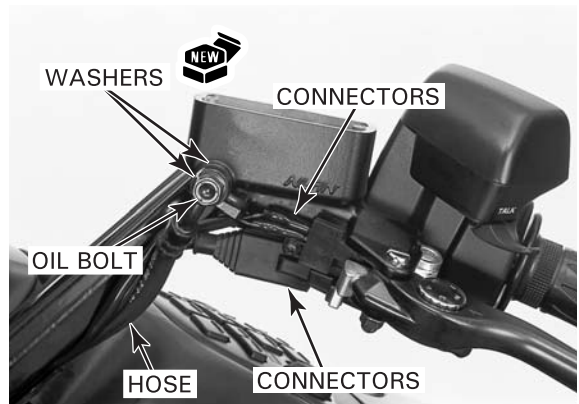

## CLUTCH SLAVE CYLINDER

### DISASSEMBLY

Drain the clutch fluid from the hydraulic system (page 9-7).

Disconnect the clutch hose from the slave cylinder by removing the oil bolt and sealing washers.

Remove the following:

- three mounting bolts
- slave cylinder

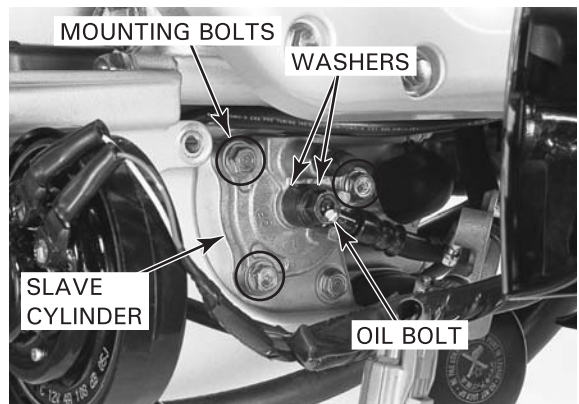

- dowel pins
- lifter rod
- oil seal

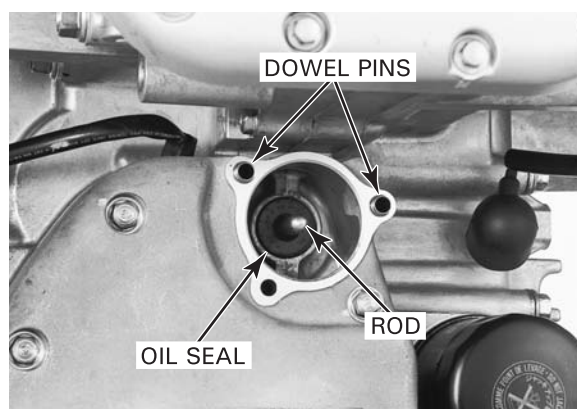

– piston

*Do not use high pressure air or bring the nozzle too close to the inlet.*

If piston removal is hard, place a shop towel over the piston, position the cylinder body with the piston down and apply small squirts of air pressure to the fluid inlet.



Remove the spring, piston seal and oil seal from the piston.

**INSPECTION**

Check the piston spring for fatigue or damage. Check the slave cylinder and piston for scoring or damage.

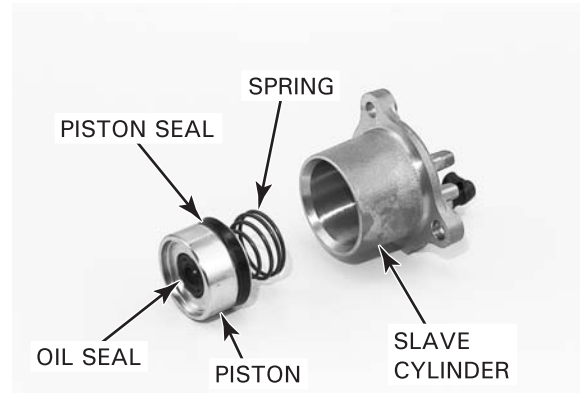

Check the clutch lifter rod for bends or damage.

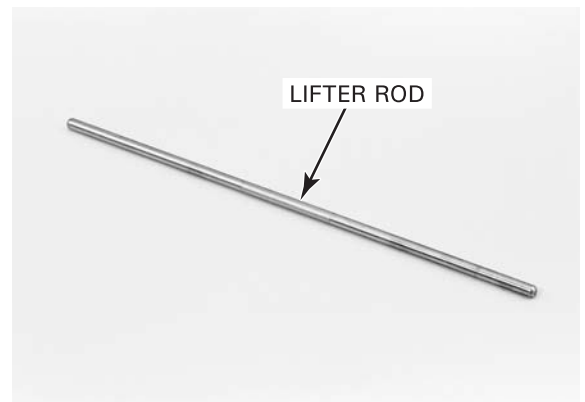

**ASSEMBLY**

Apply a small amount of silicone grease to the lifter rod contacting area of the piston.

Apply grease to the lips of a new oil seal and install it into the piston.

Install a new piston seal into the piston groove.

Install the piston spring onto the piston.

Coat the piston and piston seal with clutch fluid and install the piston and spring into the slave cylinder.

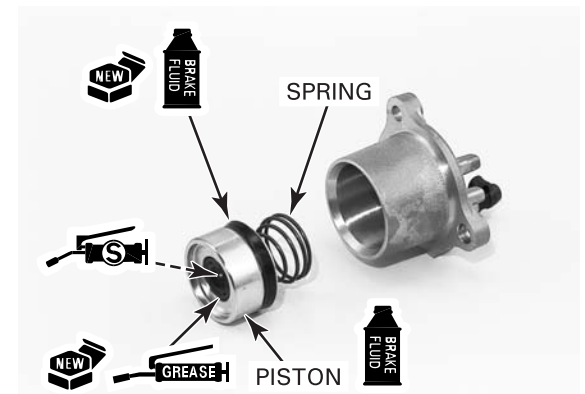



## CLUTCH

Apply grease to the lips of a new oil seal and install it into the crankcase.  
Install the lifter rod.  
Install the dowel pins.

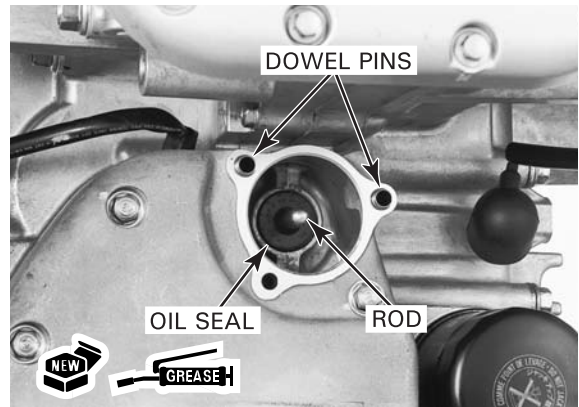

Install the slave cylinder onto the gearshift linkage cover and tighten the mounting bolts.

Connect the clutch hose with the oil bolt and new sealing washers by aligning the hose joint with the groove in the slave cylinder.  
Tighten the oil bolt.

**TORQUE: 34 N·m (3.5 kgf·m, 25 lbf·ft)**

Fill and bleed the clutch hydraulic system (page 9-7).

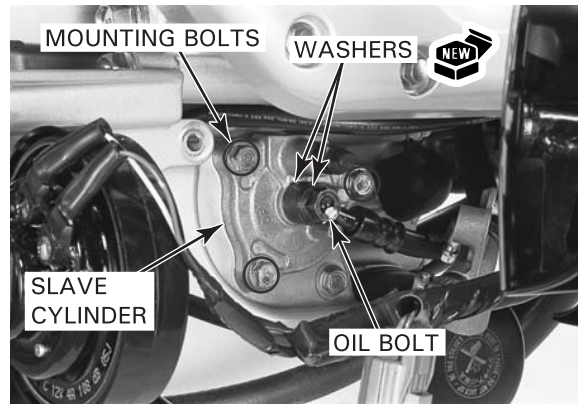

## CLUTCH

### CLUTCH COVER REMOVAL

Drain the engine oil (page 3-16).

Remove the exhaust system (page 2-18).

Remove the radiator reserve tank (page 6-8).

Remove the following:

- fuel tank drain tube from clamp
- eleven bolts and clamp
- clutch cover

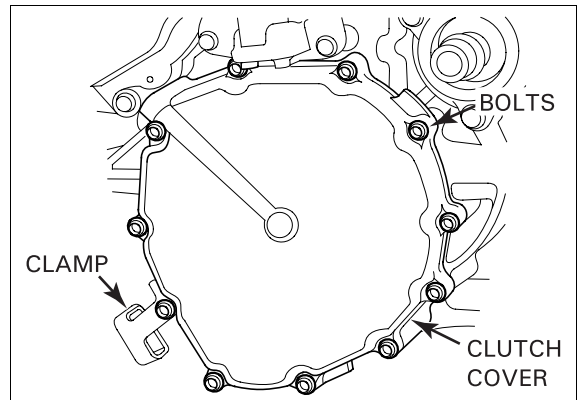

- two dowel pins
- oil through pipe and O-ring
- scavenge oil strainer

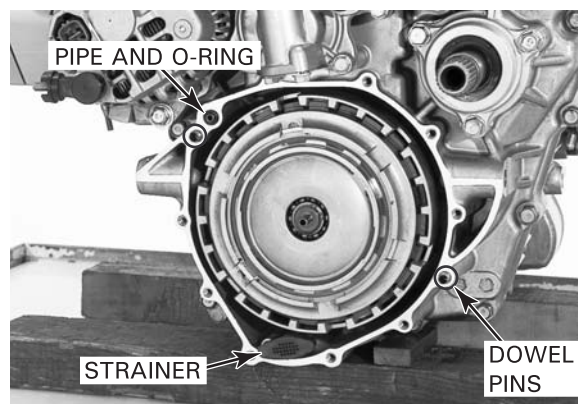

- gasket
- snap ring
- oil seal

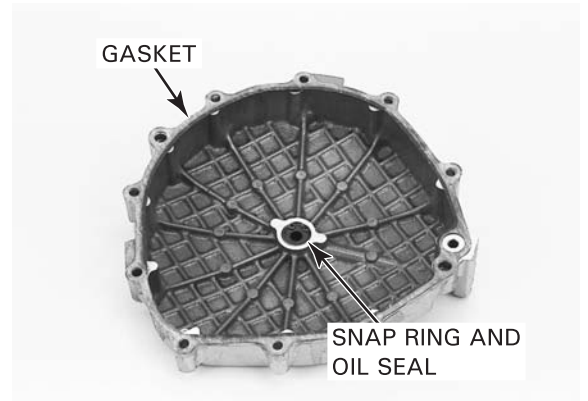

**CLUTCH DISASSEMBLY**

Remove the following:

- stopper ring
- clutch lifter plate A

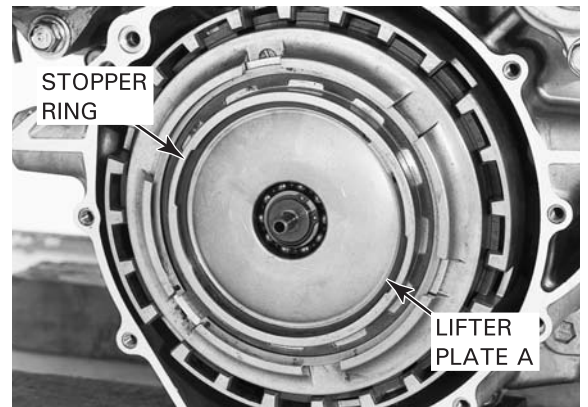

*Be careful not to damage the mainshaft threads.*

Unstake the clutch center lock nut.  
 Shift the transmission into any gear except neutral.  
 Loosen the lock nut while applying the rear brake.

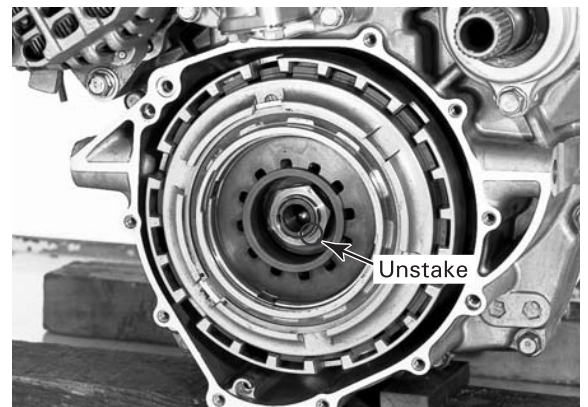

If the engine was removed from the frame, hold the output shaft with the special tool and loosen the lock nut.

**TOOL:**  
**Shaft holder**

**07PAB-0010200 or  
 07924-PJ40001  
 (U.S.A. only)**

Remove the following:

- lock nut

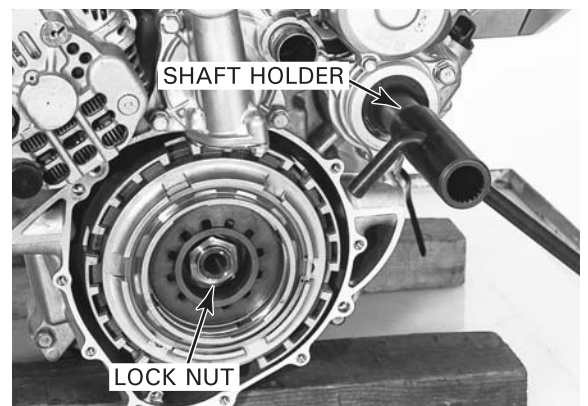

# CLUTCH

- lock washer
- spring guide
- clutch spring
- spring seat

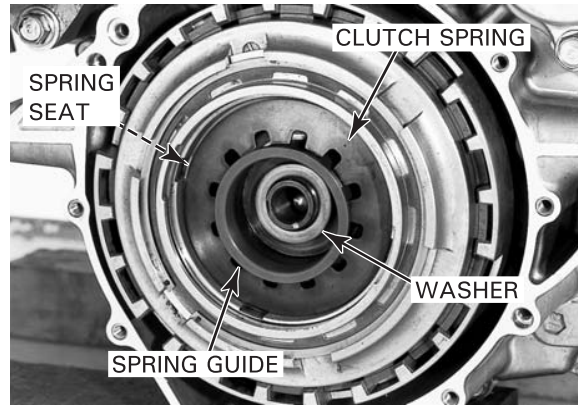

- clutch center assembly from clutch outer

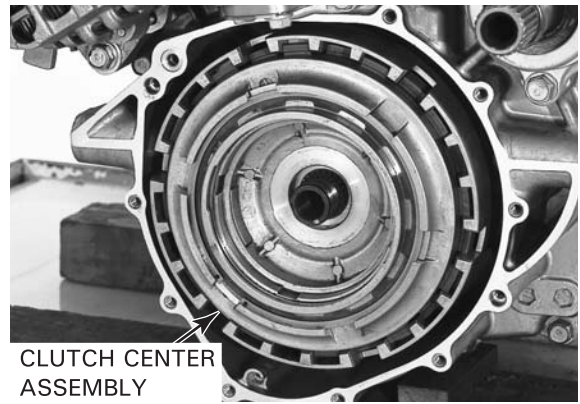

- splined washer



- stopper ring
- lifter spring
- clutch lifter plate B

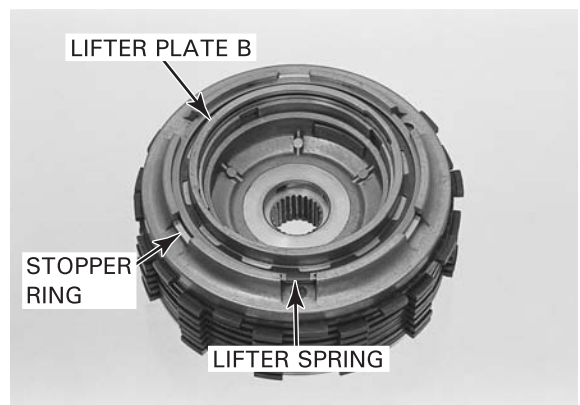

- pressure plate from clutch center
- O-ring
- clutch piston from pressure plate
- O-ring

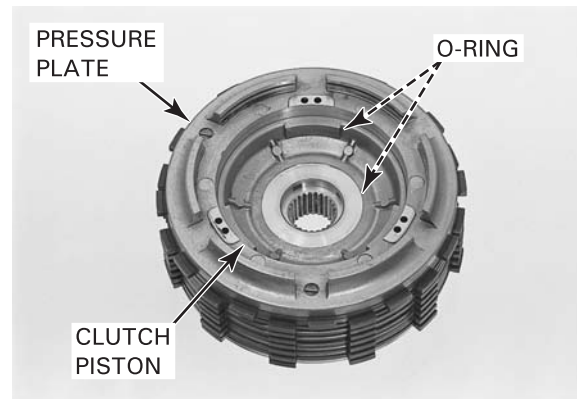

- '01 - '03:  
three clutch discs C, four clutch discs A and six clutch plates
- After '03:  
clutch disc C, six clutch discs A and six clutch plates

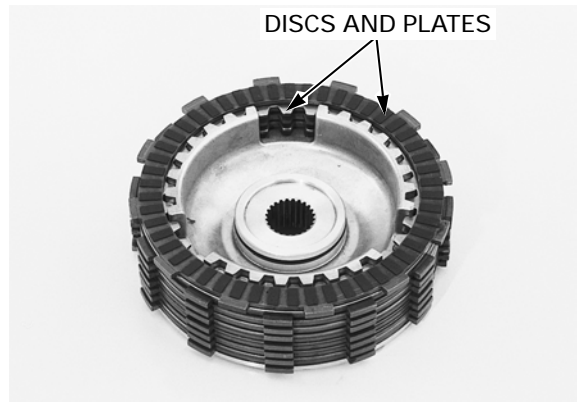

While pressing the clutch plate, push the clip wire ends from the inside of the clutch center to remove them off the wire hole in the clutch center. Continuously press the clutch plate and remove the clip wire from the clip groove in the clutch center.

- Remove the following:
- clutch plate

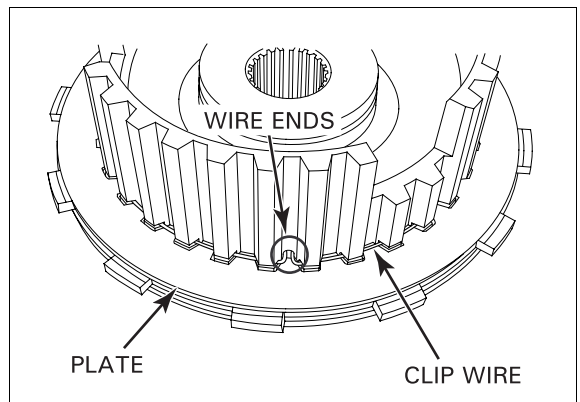

- clutch disc B
- judder spring
- spring seat

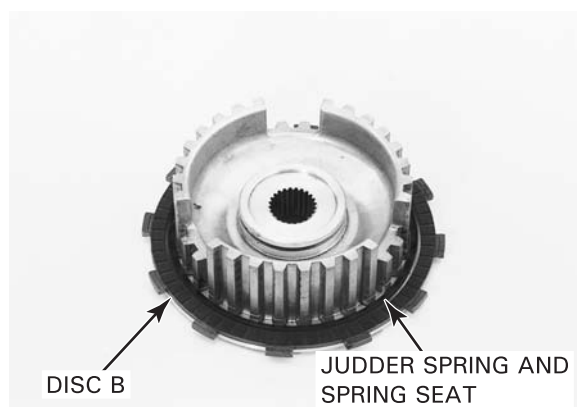



# CLUTCH

## INSPECTION

### LIFTER JOINT PIECE, LIFTER BEARING

Check the lifter joint piece for damage or abnormal wear and the oil passages in the joint piece for debris.

Turn the lifter joint piece in the lifter bearing with your finger. The bearing should turn smoothly and quietly.

Also, check that the bearing races fit tightly in the lifter plate and joint piece.

Replace the bearing as follows if the bearing does not turn smoothly, quietly, or if the races fits loosely.

Remove the snap ring and lifter joint piece.

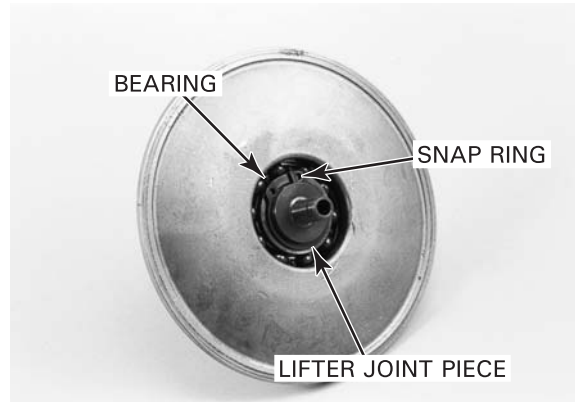

Remove the snap ring and drive the bearing out of the lifter plate.

Drive a new bearing into the plate with its mark side facing up.

### TOOLS:

<b>Driver</b>	<b>07749-0010000</b>
<b>Attachment, 32 x 35 mm</b>	<b>07746-0010100</b>
<b>Pilot, 17 mm</b>	<b>07746-0040400</b>

Install the snap ring into the lifter plate groove securely.

Install the lifter joint piece into the bearing and secure it with the snap ring.

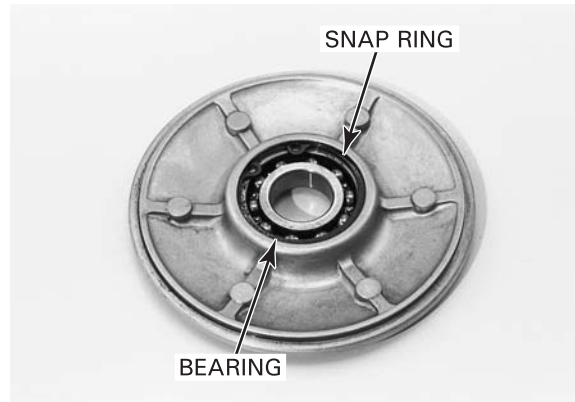

### CLUTCH DISC

*Replace the clutch discs and plates as a set.*

Check the clutch discs for signs of scoring or discoloration.

Measure the clutch disc thickness.

**SERVICE LIMIT: 3.5 mm (0.14 in)**



### CLUTCH PLATE

*Replace the clutch discs and plates as a set.*

Check the plates for discoloration.

Check for plate warpage on a surface plate using a feeler gauge.

**SERVICE LIMIT: 0.30 mm (0.012 in)**

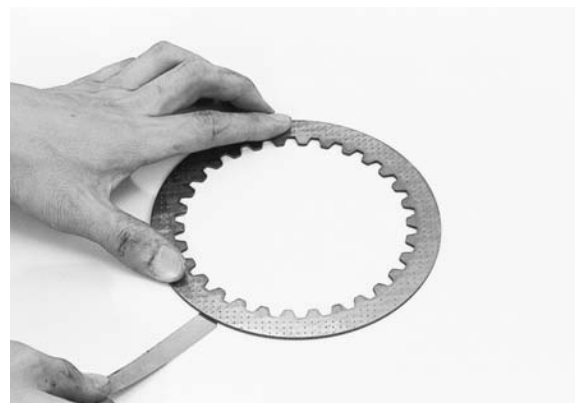

**JUDDER SPRING, SPRING SEAT**

Check the judder spring and spring seat for distortion, wear or damage.

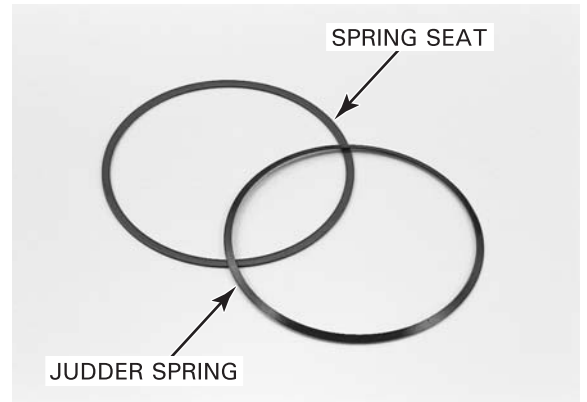
**CLUTCH SPRING, LIFTER SPRING**

Check the clutch and lifter springs for distortion. Measure the height of the clutch spring.

**SERVICE LIMIT: 4.6 mm (0.18 in)**



Measure the height of the lifter spring.

**SERVICE LIMIT: 2.5 mm (0.10 in)**

**CLUTCH CENTER**

Check the clutch center for nicks, indentations or abnormal wear made by the plates.

**PRESSURE PLATE**

Clean the inner side of the pressure plate. Check the pressure plate for abnormal wear and the oil passages for debris.

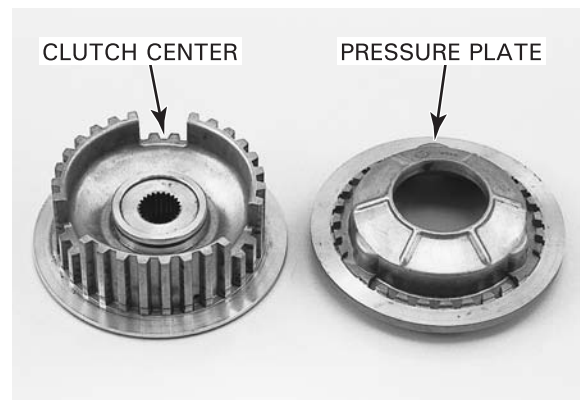

# CLUTCH

## CLUTCH OUTER

Check the slots in the clutch outer for nicks, indentations or abnormal wear made by the clutch discs.

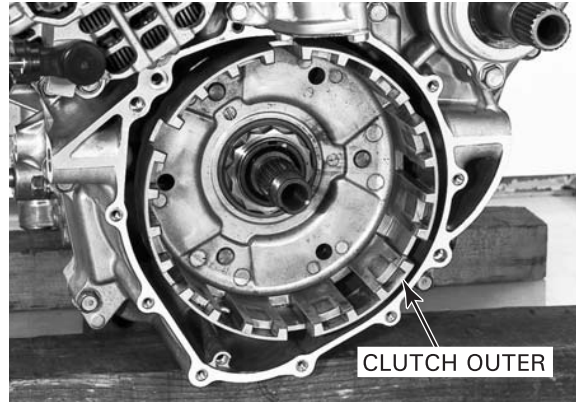

## CLUTCH OUTER REMOVAL

Remove the engine from the frame (section 7).

*Be careful not to damage the primary driven gear boss threads.*

Unstake the clutch outer lock nut.

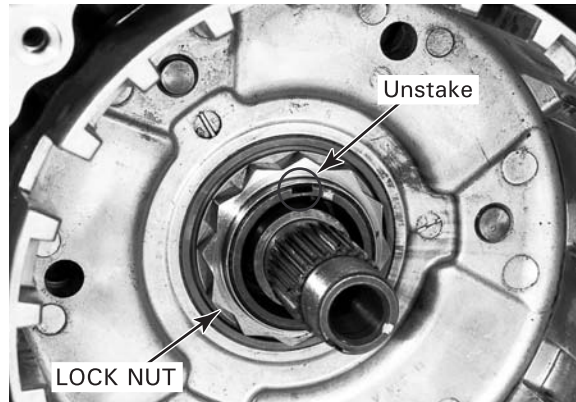

Hold the clutch outer with the special tool and loosen the clutch outer lock nut.

### TOOLS:

**Clutch outer holder**

**07JMB-MN50100**

**Lock nut wrench, 46 mm**

**07JMA-MN50100**

Remove the lock nut.

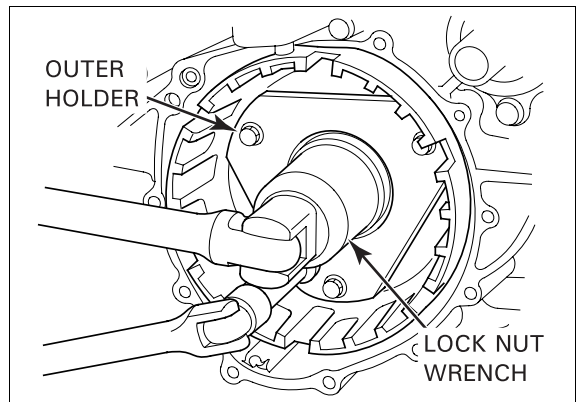

Remove the special washer and clutch outer.

## CLUTCH OUTER INSTALLATION

Clean the primary driven gear boss threads thoroughly.

Apply molybdenum oil solution to the friction spring (cone spring) on the reverse side of the clutch outer.

Install the clutch outer and the special washer with the "OUTSIDE" mark facing out.

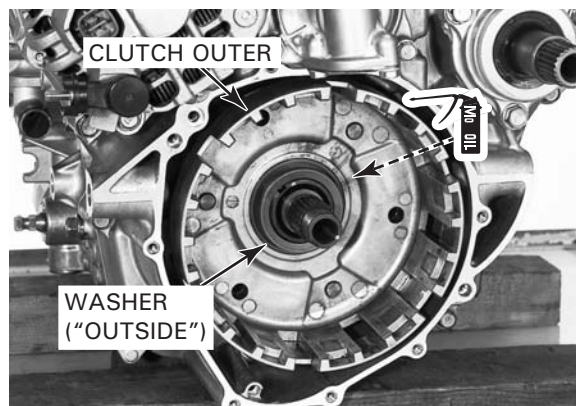



Apply locking agent to the threads of a new clutch outer lock nut and install it.

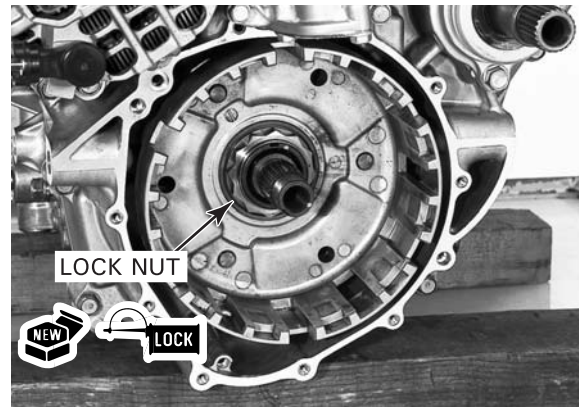

Hold the clutch outer with the special tool and tighten the lock nut.

**TOOLS:**

**Clutch outer holder**                      **07JMB-MN50100**  
**Lock nut wrench, 46 mm**              **07JMA-MN50100**

**TORQUE: 186 N·m (19.0 kgf·m, 137 lbf·ft)**

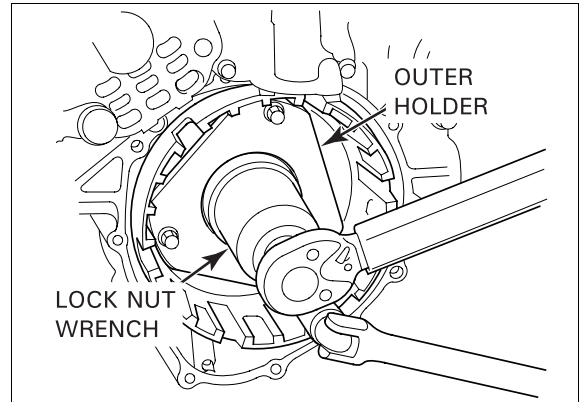

*Be careful not to damage the primary driven gear boss threads.*

Stake the lock nut into the driven gear boss groove.

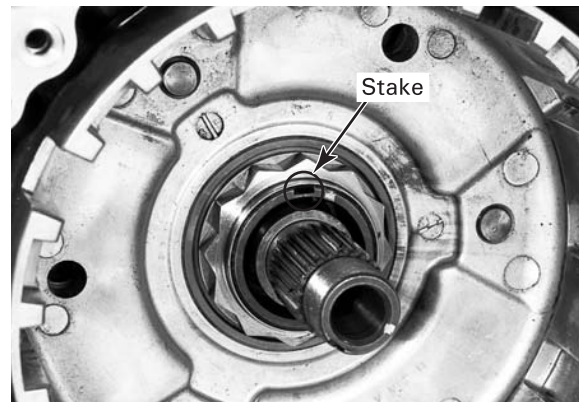

**CLUTCH ASSEMBLY**

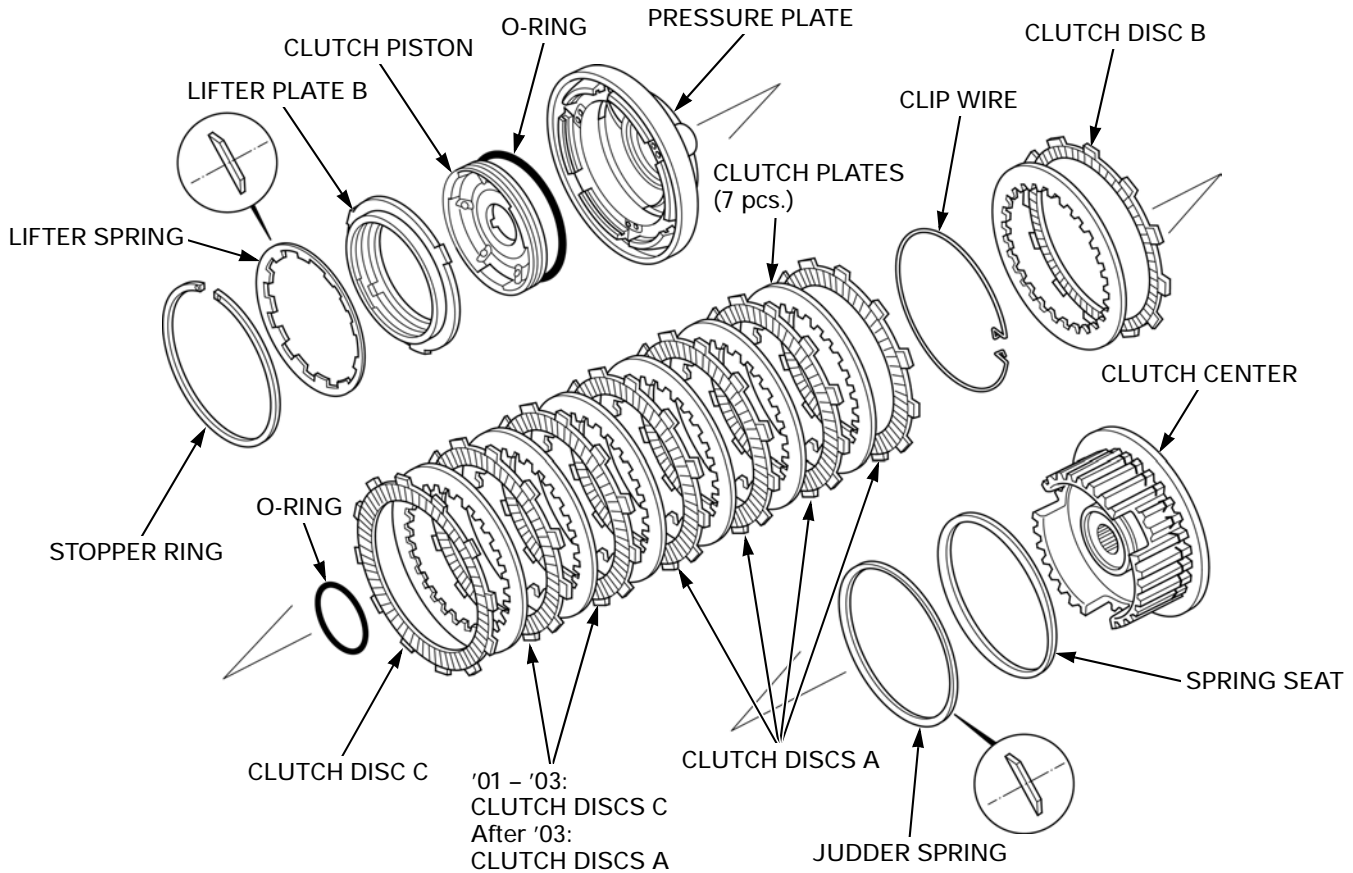

Install the spring seat and the judder spring onto the clutch center with the concaved side of the judder spring facing out.

Coat clutch discs A, B and C with clean engine oil.  
Install clutch disc B.

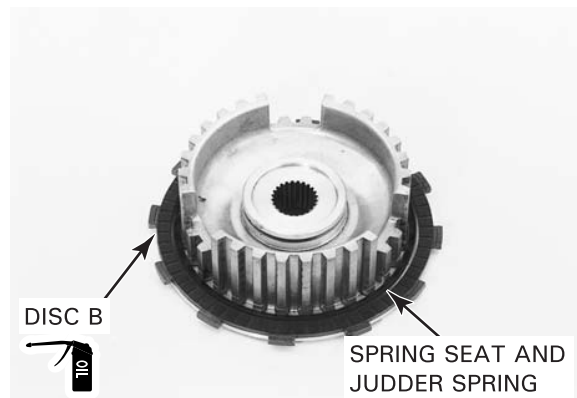

Install the clutch plate.

Install the end of a new clip wire into the hole in the clutch center.

While pressing the clutch plate, set the clip wire into the groove in the clutch center firmly and install the other end into the hole to secure it.

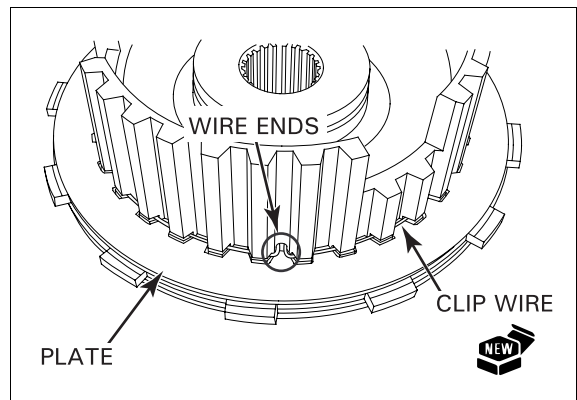

Install the seven discs and six clutch plates alternately, starting with the disc.

'01 - '03:

First, install four discs A, then three discs C; alternating between discs and plates.

After '03:

First, install six discs A, then disc C; alternating between discs and plates.

Coat a new O-ring with engine oil and install it into the groove in the clutch center boss.

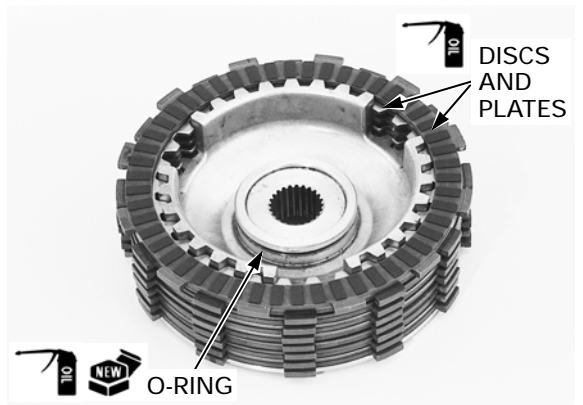

Install the pressure plate by aligning its convex areas with the grooves in the clutch center.

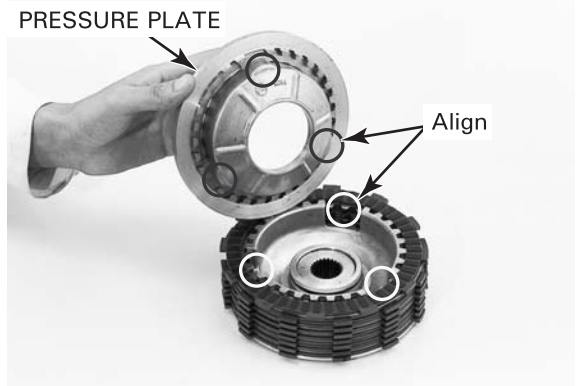

Coat a new O-ring with engine oil and install it into the groove in the clutch piston.

Install the clutch piston evenly until it is fully seated.

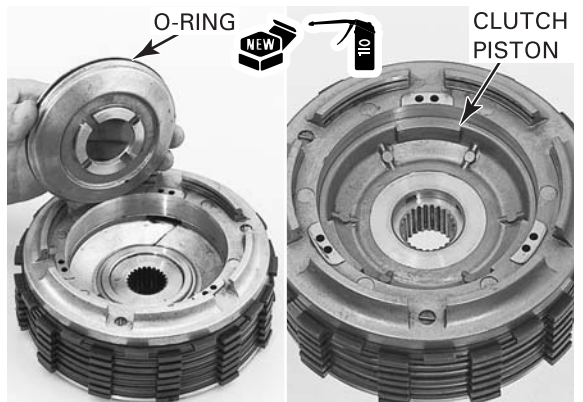

Install lifter plate B by aligning the tabs with the oil holes in the pressure plate.

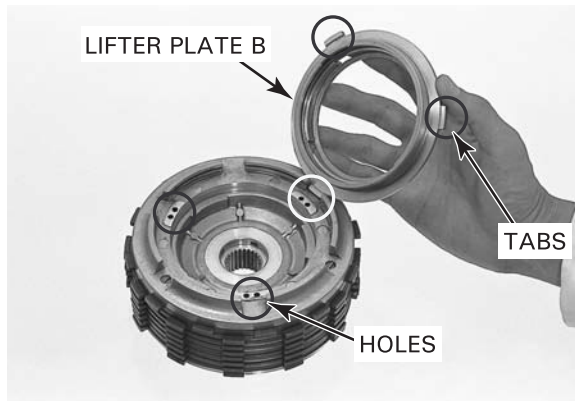

# CLUTCH

Install the lifter spring with the concaved side facing out.

*Make sure the stopper ring is seated securely.*

Install the stopper ring into the ring groove in the pressure plate.

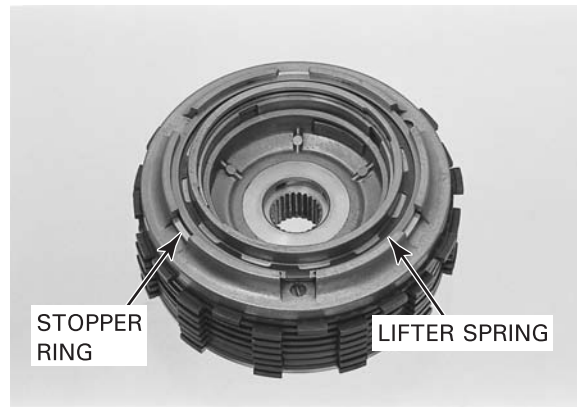
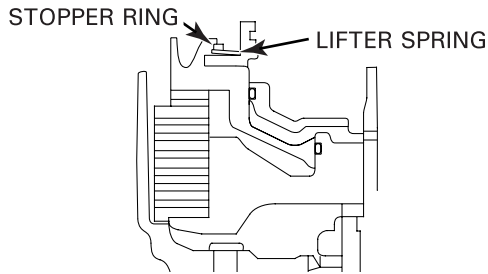

Install the splined washer onto the mainshaft.



*Install the tabs of the outside clutch disc into the shallow slots in the clutch outer.*

Line up the disc tabs carefully and install the clutch center assembly by aligning the disc tabs with the slots in the clutch outer.

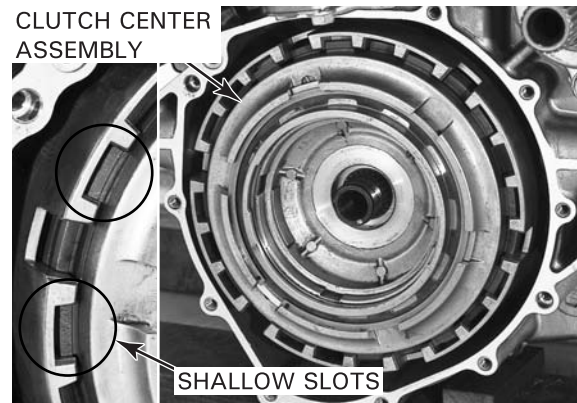

Install the spring seat with the concave side facing out.

Install the clutch spring and spring guide with the concave side of the spring facing in.

Install the lock washer.

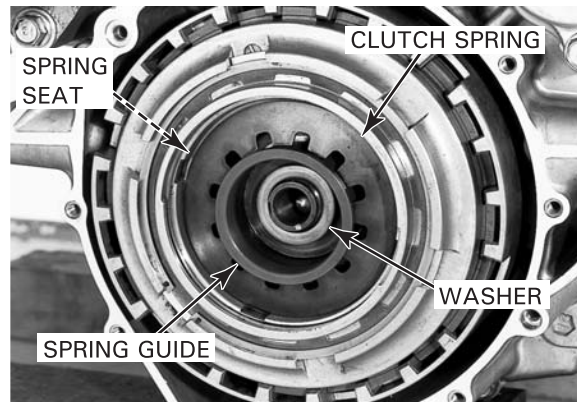
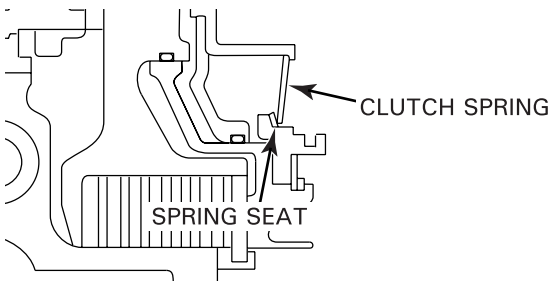



Apply engine oil to the threads and seating surface of a new lock nut, and install it.

Shift the transmission into any gear except neutral.

Apply the rear brake and tighten the lock nut.

**TORQUE: 127 N·m (13.0 kgf·m, 94 lbf·ft)**

If the engine was removed from the frame, hold the output shaft with the special tool and tighten the lock nut.

**TOOL:**  
**Shaft holder**

**07PAB-0010200 or  
07924-PJ40001  
(U.S.A. only)**

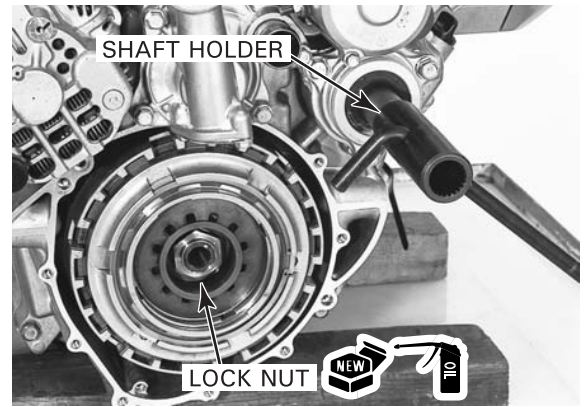

*Be careful not to damage the mainshaft threads.* Stake the lock nut into the mainshaft groove.

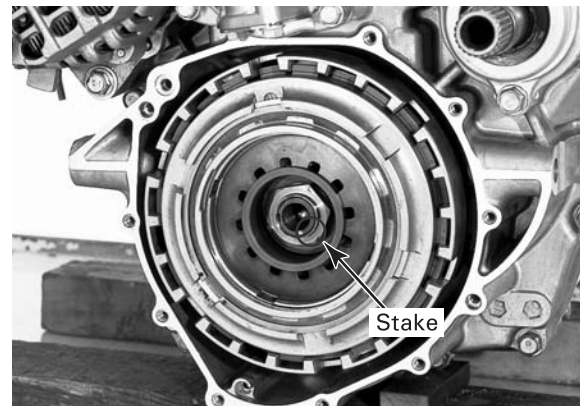

Apply engine oil to the sliding surface of the lifter joint piece.

*Make sure the stopper ring is seated securely.* Install lifter plate A and secure it with the stopper ring.

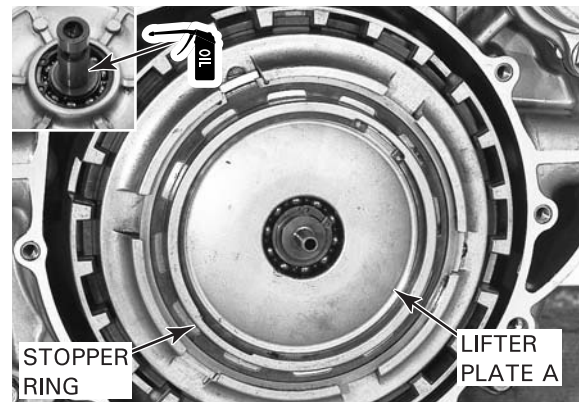

**CLUTCH COVER INSTALLATION**

Apply grease to the lips of a new lifter joint piece oil seal.

Install the oil seal into the clutch cover with the flat side facing up until the snap ring groove is visible.

Install the snap ring into the cover groove securely.

**TOOL:**  
**Pilot, 17 mm  
Driver**

**07746-0040400  
07749-0010000**

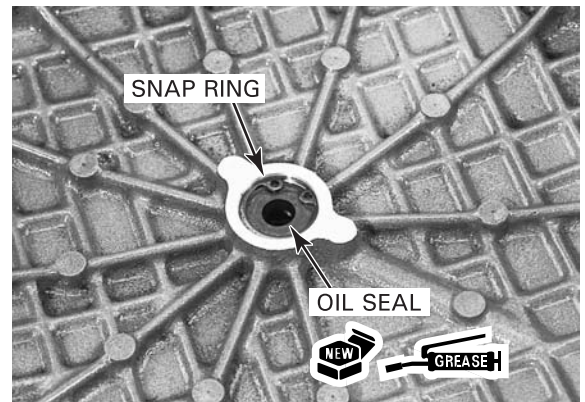

## CLUTCH

Clean the gasket mating surfaces of the clutch cover and rear crankcase cover thoroughly, being careful not to damage them.

Install the scavenge oil strainer.

Coat a new O-ring with engine oil and install the oil through pipe and O-ring.  
Install the two dowel pins.

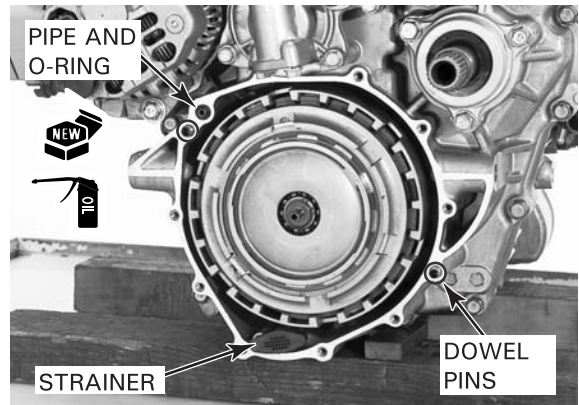

Install a new gasket.

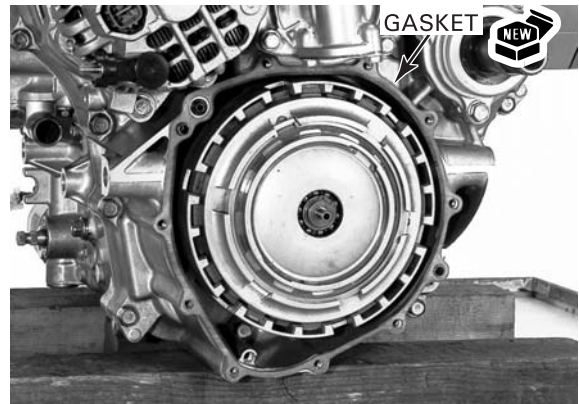

Install the clutch cover, being careful not to damage the oil seal in the cover.

Install the 11 cover bolts with the clamp and tighten them in a crisscross pattern in several steps.

Install the radiator reserve tank (page 6-8).

Install the fuel tank drain tube and reserve tank breather tube into the clamp on the clutch cover properly (page 1-23).

Install the exhaust system (page 2-18).

Fill the crankcase with the recommended engine oil (page 3-11).

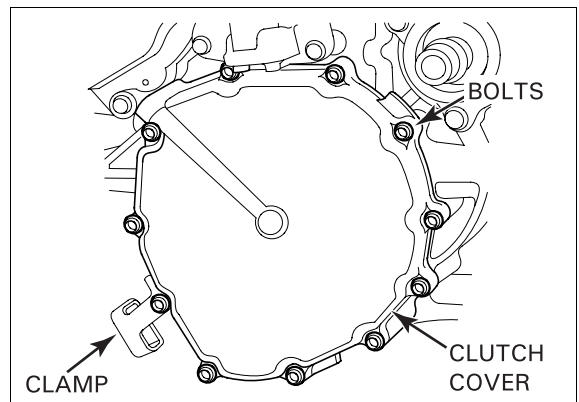

# 10. GEARSHIFT LINKAGE/TRANSMISSION

---

COMPONENT LOCATION .....	10-2	CRANKCASE COVER BEARING REPLACEMENT .....	10-19
SERVICE INFORMATION .....	10-4	PRIMARY GEARS/OUTPUT SHAFT INSTALLATION.....	10-20
TROUBLESHOOTING .....	10-7	REAR CRANKCASE COVER INSTALLATION.....	10-24
GEARSHIFT LINKAGE .....	10-8	TRANSMISSION DISASSEMBLY .....	10-26
REAR CRANKCASE COVER REMOVAL ...	10-11	TRANSMISSION ASSEMBLY .....	10-33
PRIMARY GEARS/OUTPUT SHAFT REMOVAL .....	10-13		



# GEARSHIFT LINKAGE/TRANSMISSION

## COMPONENT LOCATION

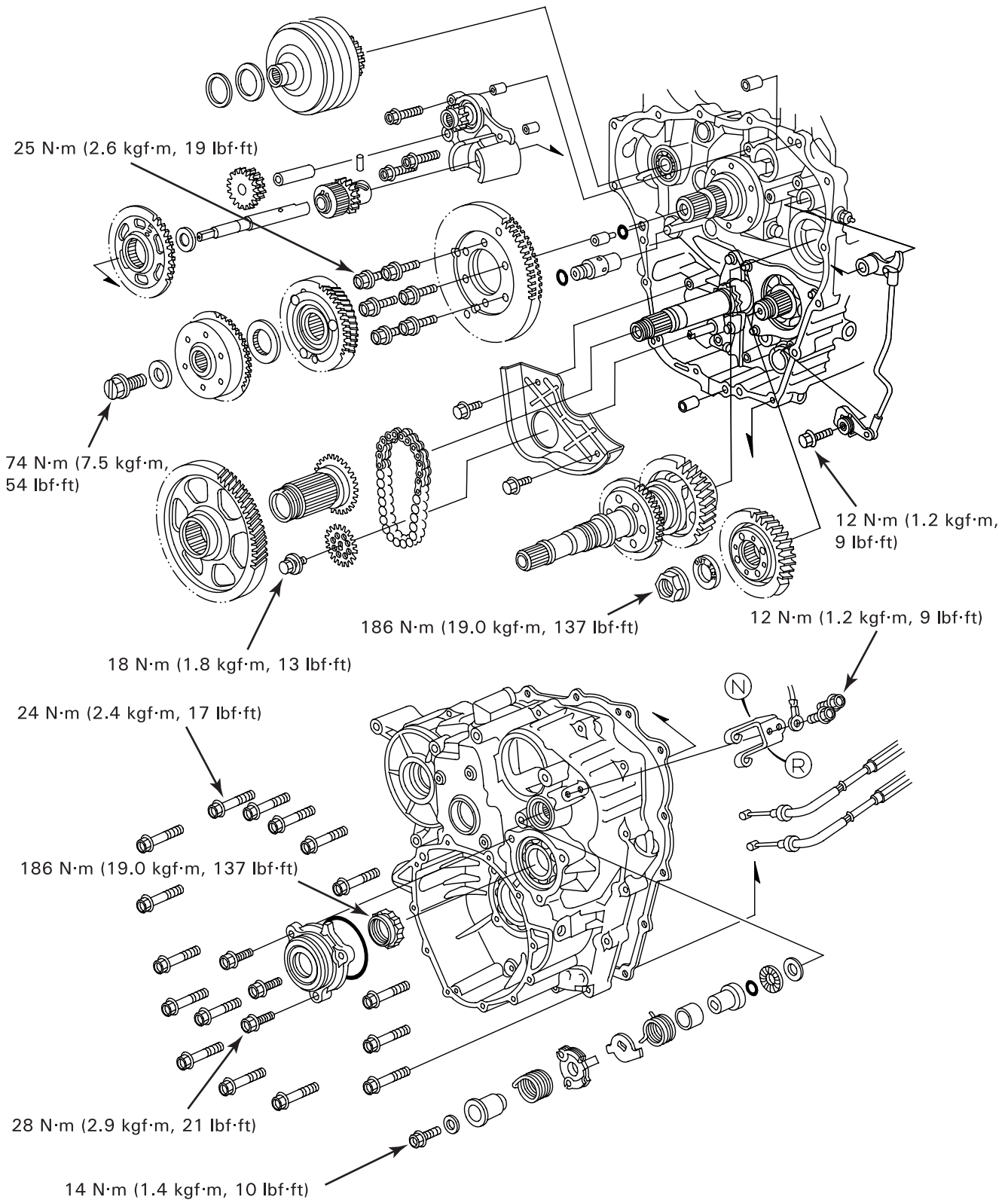

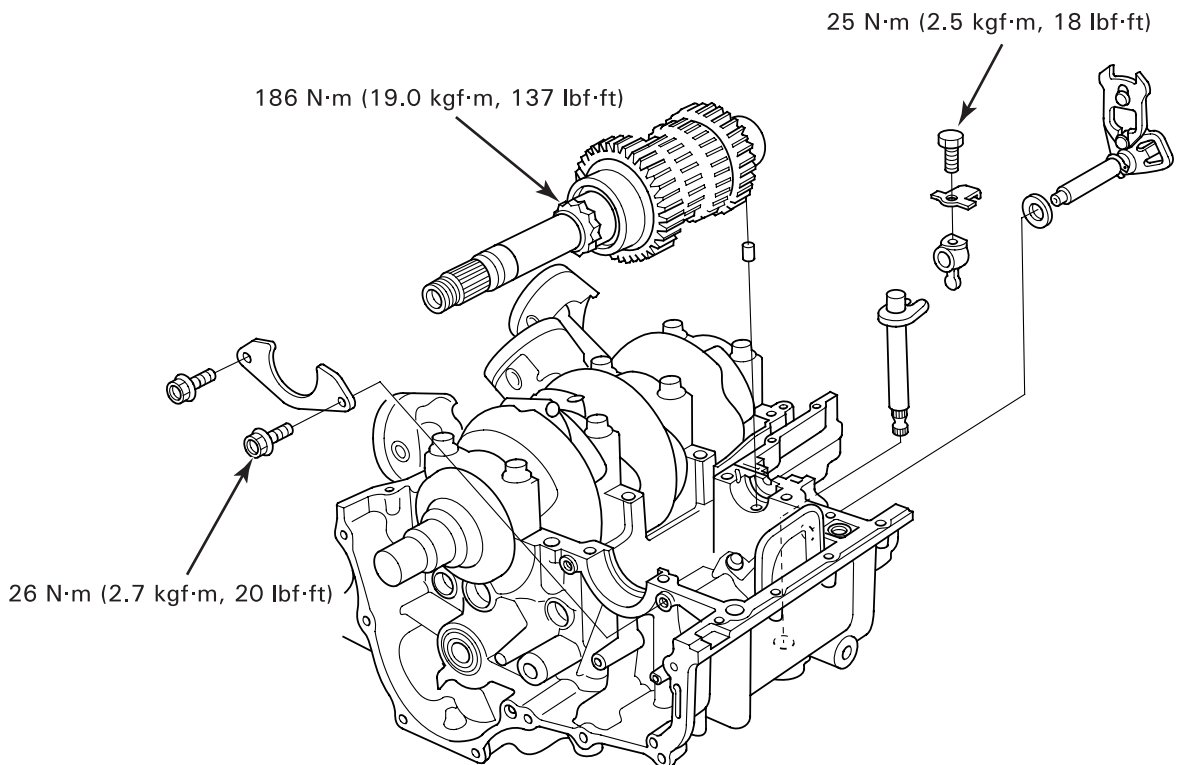
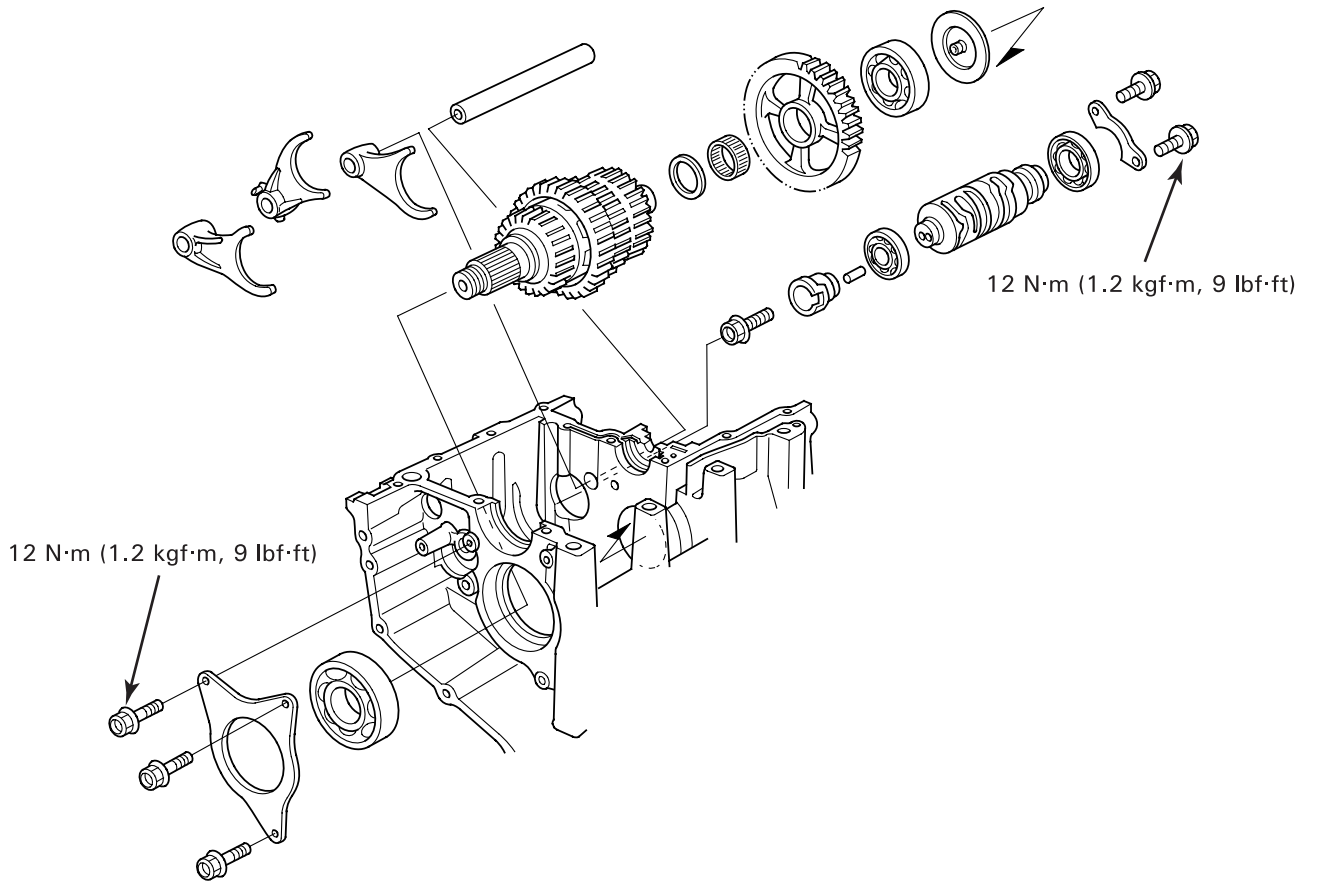

## GEARSHIFT LINKAGE/TRANSMISSION

# SERVICE INFORMATION

### GENERAL

- The gearshift linkage can be serviced with the engine installed in the frame with the exception of the gearshift spindle. The engine must be removed from the frame to service the primary gears and output shaft. Refer to section 7 for engine removal and installation.  
The crankcase must be separated to service the transmission (including gearshift spindle). Refer to section 11 for crankcase separation and assembly.
- Refer to section 18 for reverse shift system service.
- Be careful not to damage the crankcase mating surfaces when servicing the transmission.
- When using the lock nut wrench for the lock nuts of the output shaft and mainshaft bearing, use a deflecting beam type torque wrench 20 inches long. The lock nut wrench increases the torque wrench's leverage, so the torque wrench reading will be less than the torque actually applied to the lock nut. The specification given is the actual torque applied to the lock nut, not the reading on the torque wrench. Do not overtighten the lock nut. The specification later in the text gives both actual and indicated.

### SPECIFICATIONS





Unit: mm (in)

ITEM		STANDARD	SERVICE LIMIT	
Output shaft	Damper spring free length	66.0 (2.60)	64.0 (2.52)	
	Shaft O.D.	22.008 – 22.021 (0.8665 – 0.8670)	21.99 (0.866)	
	Gear bushing	I.D.	22.026 – 22.041 (0.8672 – 0.8678)	22.05 (0.868)
		O.D.	25.959 – 25.980 (1.0220 – 1.0228)	25.95 (1.022)
Driven gear I.D.	26.000 – 26.013 (1.0236 – 1.0241)	26.03 (1.025)		
Shift fork	I.D.	14.000 – 14.018 (0.5512 – 0.5519)	14.04 (0.553)	
	Claw thickness	5.93 – 6.00 (0.233 – 0.236)	5.6 (0.22)	
Shift fork shaft	O.D.	13.966 – 13.984 (0.5498 – 0.5506)	13.90 (0.547)	
Transmission	Gear I.D.	M4	31.000 – 31.025 (1.2205 – 1.2215)	31.04 (1.222)
		M5	35.000 – 35.025 (1.3780 – 1.3789)	35.04 (1.380)
		C2, C3	33.000 – 33.025 (1.2992 – 1.3002)	33.04 (1.301)
	Gear bushing O.D.	M4	30.950 – 30.975 (1.2186 – 1.2195)	30.93 (1.218)
		M5	34.950 – 34.975 (1.3760 – 1.3770)	34.93 (1.375)
		C2, C3	32.950 – 32.975 (1.2972 – 1.2982)	32.93 (1.296)
	Gear-to-bushing clearance		0.025 – 0.075 (0.0010 – 0.0030)	0.10 (0.004)
	Gear bushing I.D.	M4	28.007 – 28.028 (1.1026 – 1.1035)	28.04 (1.104)
		M5	32.007 – 32.028 (1.2601 – 1.2609)	32.04 (1.261)
	Mainshaft O.D.	at M4	27.987 – 28.000 (1.1018 – 1.1024)	27.96 (1.101)
at M5		31.987 – 32.000 (1.2593 – 1.2598)	31.96 (1.258)	
Bushing-to-shaft clearance		0.007 – 0.041 (0.0003 – 0.0016)	0.08 (0.003)	



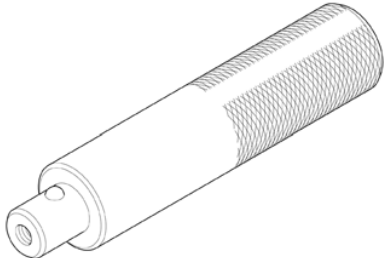
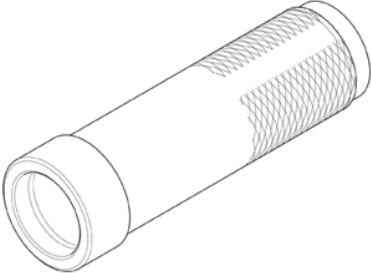



**TORQUE VALUES**

Shift drum stopper arm pivot bolt	12 N·m (1.2 kgf·m, 9 lbf·ft)	Apply locking agent to the threads. Apply engine oil to the threads and seating surface/stake the nut.
Shift drum joint bolt	27 N·m (2.8 kgf·m, 20 lbf·ft)	
Mainshaft bearing lock nut	186 N·m (19.0 kgf·m, 137 lbf·ft)	
Countershaft setting plate bolt	12 N·m (1.2 kgf·m, 9 lbf·ft)	Apply locking agent to the threads. Apply locking agent to the threads. Apply locking agent to the threads. Apply locking agent to the threads.
Mainshaft setting plate bolt	26 N·m (2.7 kgf·m, 20 lbf·ft)	
Shift drum reverse lock cam bolt	12 N·m (1.2 kgf·m, 9 lbf·ft)	
Shift drum bearing setting plate bolt	12 N·m (1.2 kgf·m, 9 lbf·ft)	
Gearshift spindle arm bolt	25 N·m (2.5 kgf·m, 18 lbf·ft)	
Gearshift spindle return spring pin	25 N·m (2.5 kgf·m, 18 lbf·ft)	
Final drive gear lock nut	186 N·m (19.0 kgf·m, 137 lbf·ft)	Apply engine oil to the threads and seating surface/left-hand threads/ stake the nut.
Alternator drive gear bolt	25 N·m (2.6 kgf·m, 19 lbf·ft)	Apply engine oil to the threads and seating surface.
Oil pump driven sprocket bolt	18 N·m (1.8 kgf·m, 13 lbf·ft)	Apply locking agent to the threads.
Starter clutch bolt	74 N·m (7.5 kgf·m, 54 lbf·ft)	Left-hand threads.
Primary driven gear bearing setting plate bolt (rear crankcase cover)	12 N·m (1.2 kgf·m, 9 lbf·ft)	Apply locking agent to the threads.
Rear crankcase cover bolt	24 N·m (2.4 kgf·m, 17 lbf·ft)	
Output shaft lock nut	186 N·m (19.0 kgf·m, 137 lbf·ft)	Stake the lock nut.
Output shaft bearing holder bolt	28 N·m (2.9 kgf·m, 21 lbf·ft)	

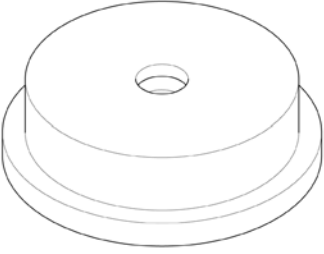
**TOOLS**

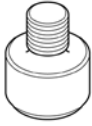
<p>Driver 07749-0010000</p> 	<p>Driver, 40 mm 07746-0030100</p> 	<p>Attachment, 28 x 30 mm 07946-1870100</p> 
<p>Attachment, 32 x 35 mm 07746-0010100</p> 	<p>Attachment, 42 x 47 mm 07746-0010300</p> 	<p>Attachment, 62 x 68 mm 07746-0010500</p> 

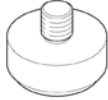
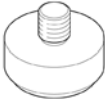
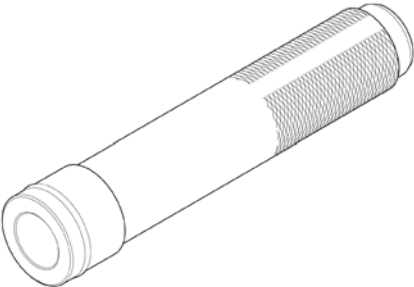
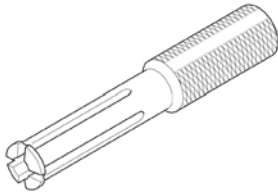
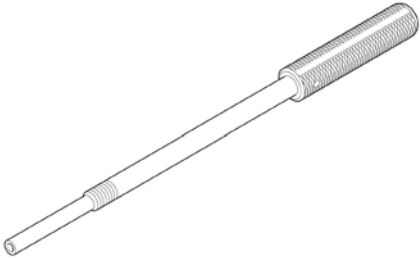
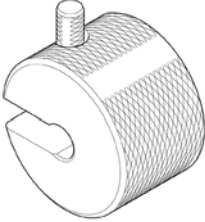
# GEARSHIFT LINKAGE/TRANSMISSION

<p>Attachment, 78 x 90 mm 07GAD-SD40101</p> 	<p>Attachment, 30 mm I.D. 07746-0030300</p> 	<p>Pilot, 16 mm 07746-0041300</p> 
<p>Pilot, 20 mm 07746-0040500</p> 	<p>Pilot, 25 mm 07746-0040600</p> 	<p>Pilot, 28 mm 07746-0041100</p> 
<p>Pilot, 30 mm 07746-0040700</p> 	<p>Driver, 22 mm I.D. 07746-0020100</p> 	<p>Bearing remover, 12 mm 07936-1660110</p> 
<p>Remover shaft 07936-1660120</p>  <p>or 07936-166010A (U.S.A. only)</p>	<p>Remover weight 07741-0010201</p>  <p>or 07936-371020A or 07936-3710200 (U.S.A. only)</p>	<p>Shaft holder 07PAB-0010200</p>  <p>or 07924-PJ40001 (U.S.A. only)</p>

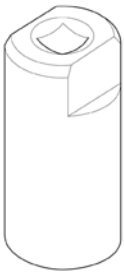
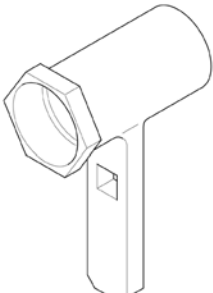
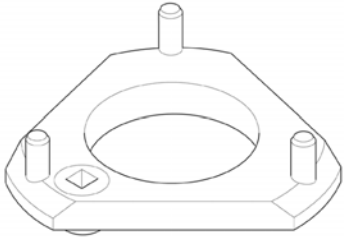
<p>Shaft holder 07JMB-MN50200</p> 	<p>Lock nut wrench, 30 x 64 mm 07916-MB00002</p>  <p>or 07916-MB00001</p>	<p>Clutch outer holder 07JMB-MN50100</p> 
---	--	--

## TROUBLESHOOTING

### Hard to shift

- Improper clutch operation (section 9)
- Incorrect engine oil viscosity
- Damaged gearshift cam
- Bent shift forks
- Bent shift fork shaft
- Bent shift fork claw
- Damaged shift drum cam grooves
- Damaged spindle arm
- Bent or damaged gearshift spindle

### Transmission jumps out of gear

- Worn or damaged gearshift cam
- Broken drum stopper arm spring
- Worn gear dogs
- Worn gear shifter groove
- Bent shift fork shaft
- Broken shift drum stopper arm
- Worn or bent shift forks
- Broken gearshift spindle return spring

### Excessive engine noise

- Worn or damaged transmission gears or bearing
- Worn or damaged primary drive and driven gears or bearing
- Worn or damaged alternator drive and driven gears or bearing
- Worn or damaged final drive and driven gears or bearing



## GEARSHIFT LINKAGE

### DISASSEMBLY

#### NOTE:

- Refer to page 10-26 "Transmission Disassembly" for gearshift spindle service.

Drain the engine oil (page 3-16).

Remove the EVAP canister (page 5-74).

Shift the transmission into neutral.

Remove the following:

- three bolts and clutch slave cylinder
- two dowel pins

*Do not disconnect the clutch hose.*

To keep the slave cylinder piston from being forced out of the cylinder, squeeze the clutch lever and tie it to the handlebar.

*Support the linkage cover so it does not hang from the gear position switch wire.*

Remove the following:

- seven cover bolts
- gearshift linkage cover

- two dowel pins
- grommet from cover
- two bolts and gear position switch
- gasket

- bolt and shift drum joint
- four dowel pins

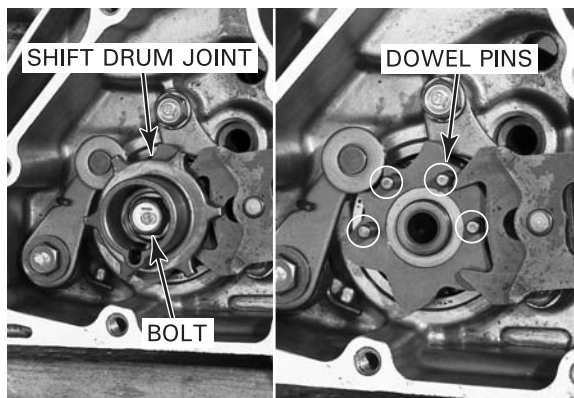
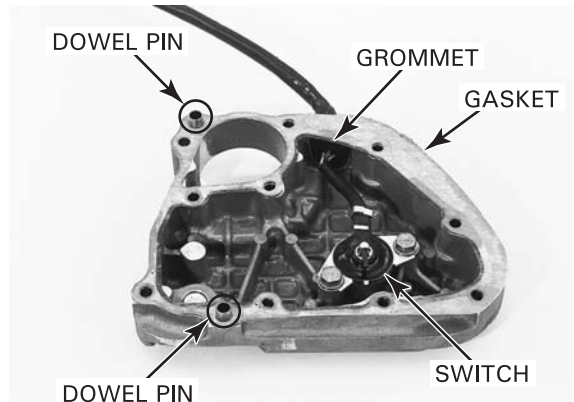
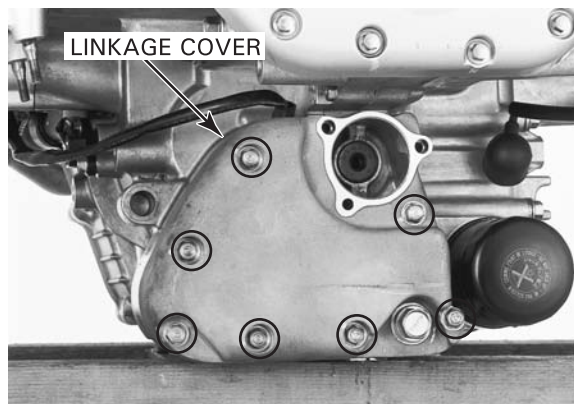
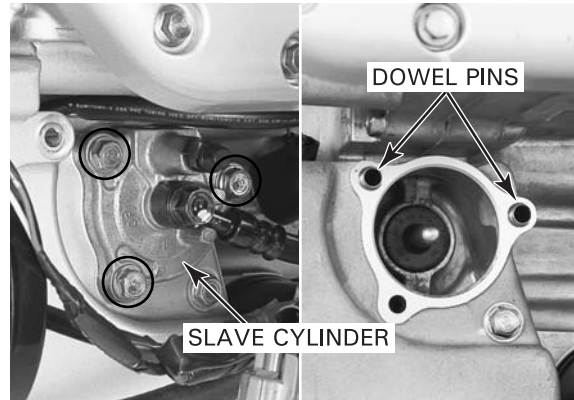

- shift drum cam (lift stopper arm with a screwdriver)
- dowel pin
- pivot bolt
- stopper arm
- return spring
- washer

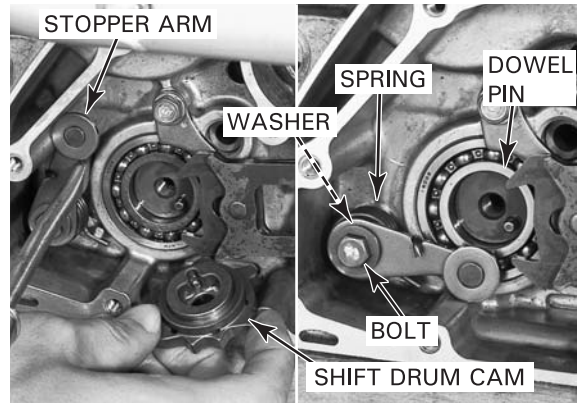

### ASSEMBLY

Install the return spring onto the crankcase as shown.

Install the washer (between the arm and crankcase) and stopper arm with the bolt.

**TORQUE: 12 N·m (1.2 kgf·m, 9 lbf·ft)**

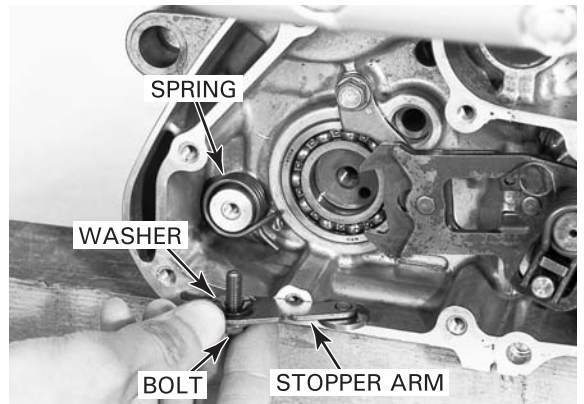

Install the dowel pin into the shift drum.

Lift the stopper arm with a screwdriver and install the shift drum cam by aligning the pin groove with the dowel pin.

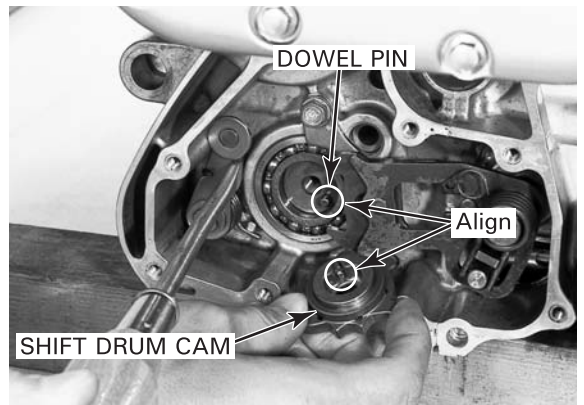

Install the four dowel pins into the shift drum cam.

Apply locking agent to the threads of the shift drum joint bolt.

Install the shift drum joint by aligning the holes with the dowel pins.

Install the bolt and tighten it.

**TORQUE: 27 N·m (2.8 kgf·m, 20 lbf·ft)**

Check the gearshift linkage operation and shift the transmission into neutral.

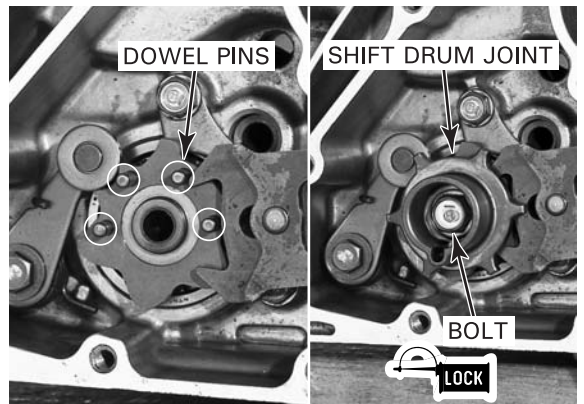

## GEARSHIFT LINKAGE/TRANSMISSION

Install the gear position switch with the bolts.

Install the wire grommet into the cover groove securely.

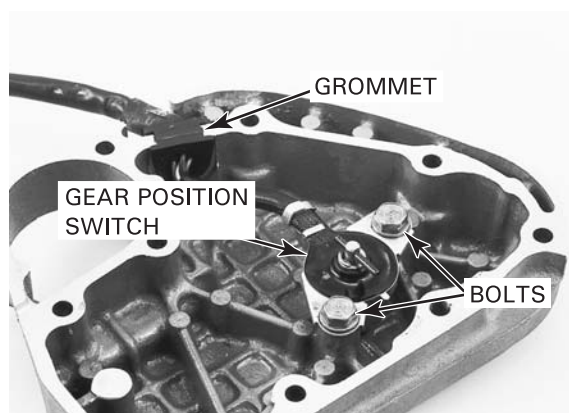

Apply sealant to the mating areas of the crankcase as shown.

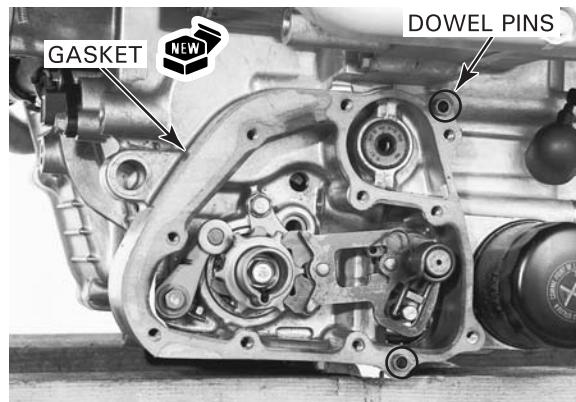
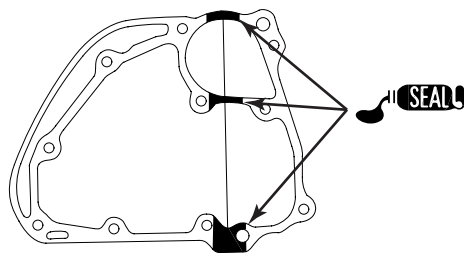

Install the two dowel pins and a new gasket.

Make sure the pin groove in the shift drum joint faces down (transmission is in neutral).

Align the long end of the switch pin with the tab on the switch.

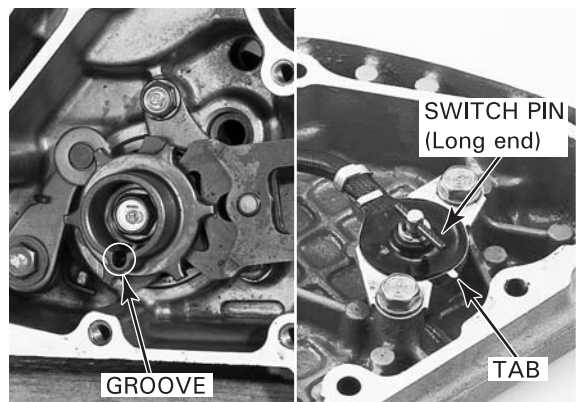

Install the linkage cover, being careful not to damage the switch pin.

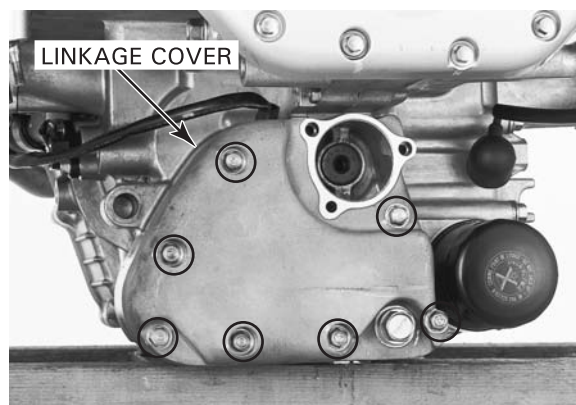
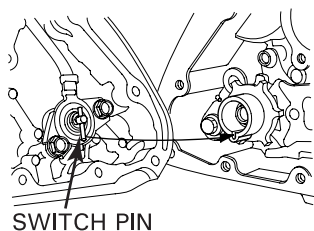

Install the seven bolts and tighten them.



Install the two dowel pins.  
 Install the slave cylinder and tighten the three bolts.  
 Release the clutch lever from the handlebar.  
 Install the EVAP canister (page 5-74).  
 Fill the crankcase with the recommended engine oil (page 3-11).

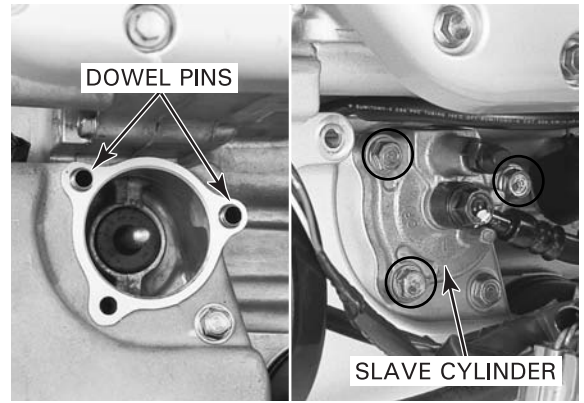

**REAR CRANKCASE COVER REMOVAL**

- Remove the following:
- engine (section 7)
  - reverse shift arm/cables (page 19-42)
  - starter/reverse motor (page 19-17)
  - alternator (page 17-10)
  - water pump (page 6-17)
  - clutch outer (page 9-20)

Remove the three bolts and the output shaft bearing holder.  
 Remove the O-ring and oil seal.

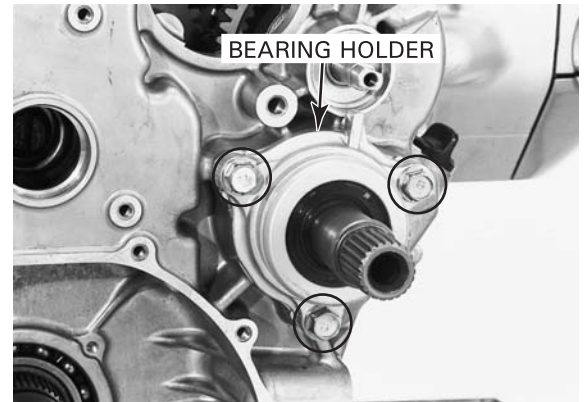

*Be careful that metal particles do not enter the bearing and that the output shaft threads are not damaged.*

Unstake the lock nut with a drill or grinder.

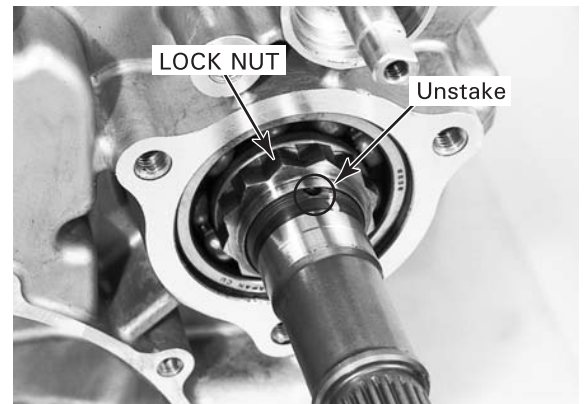

Hold the output shaft and loosen the lock nut, using the special tools and breaker bar.

**TOOLS:**

- Shaft holder** 07PAB-0010200 or 079249-PJ40001 (U.S.A. only)  
**Lock nut wrench, 30 x 64 mm** 07916-MB00002 or 07916-MB00001

Remove the lock nut and discard it.

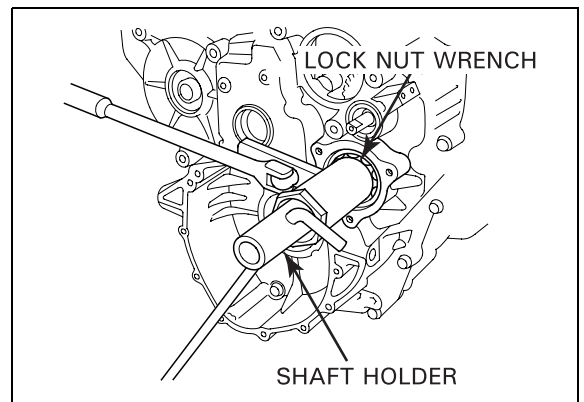

## GEARSHIFT LINKAGE/TRANSMISSION

Remove the following:

- sixteen cover bolts in a crisscross pattern in several steps

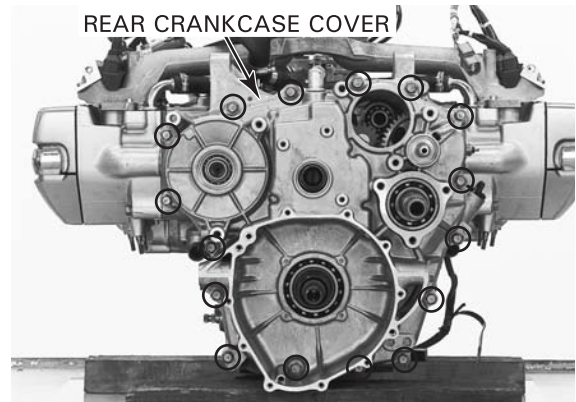

- two dowel pins
- oil orifice and O-ring

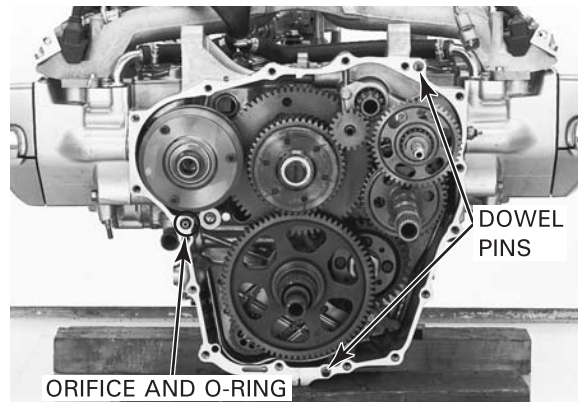

- clutch regulator valve and O-ring
- gasket

Turn the inner race of each bearing with your finger. The bearings should turn smoothly and quietly. Also check that the bearing outer race fits tightly in the cover.

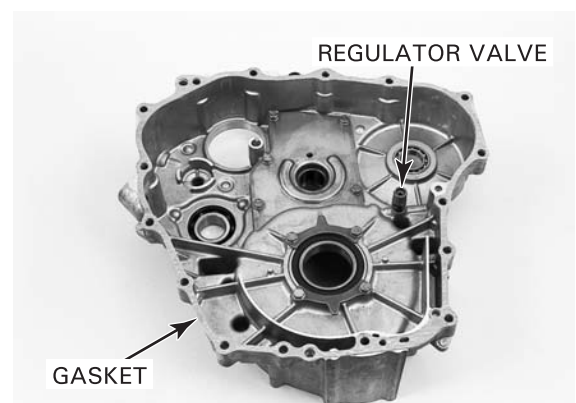

### CLUTCH REGULATOR VALVE CHECK

Remove the following:

- snap ring
- spring seat
- valve spring
- piston

Check the piston for wear, unsmooth movement or other damage.

Check the spring for fatigue or damage.

Install the piston, spring and spring seat, and secure them with the snap ring.

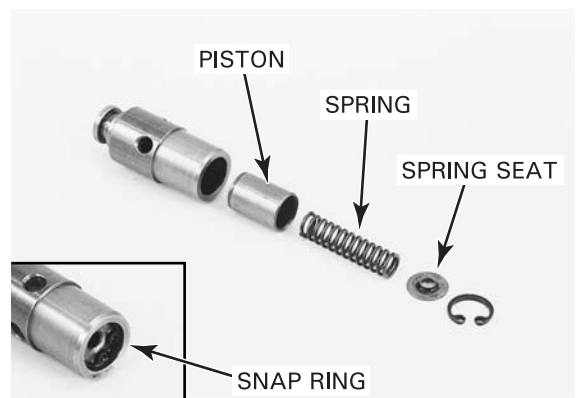

# PRIMARY GEARS/OUTPUT SHAFT REMOVAL

Remove the rear crankcase cover (page 10-11).

*Do not disassemble the driven gear assembly.*

Remove the following:

- starter reduction gear and shaft



- plain washer
- friction spring
- alternator driven gear assembly (align the gear teeth of the scissor gears [alternator drive gear and sub-gear] by inserting a screwdriver into the gear holes and prying the scissor gears)

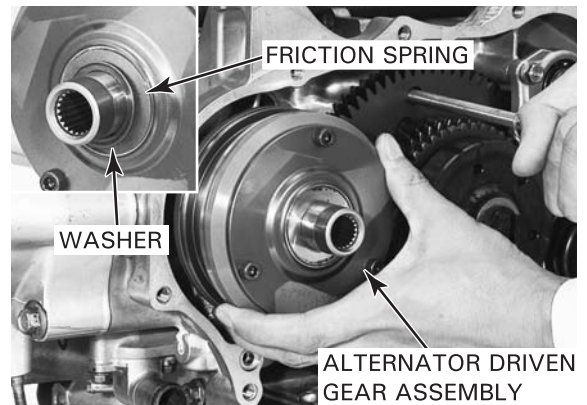

Temporarily install the clutch outer onto the primary driven gear boss.

*The starter clutch bolt has left-hand threads.*

Hold the clutch outer with the special tool and loosen the starter clutch bolt.

**TOOL:**

**Clutch outer holder** 07JMB-MN50100

Remove the clutch outer.

Remove the following:

- starter clutch bolt
- washer
- starter clutch assembly

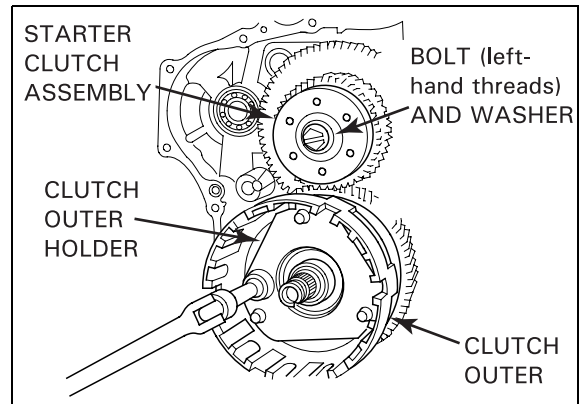

*Replace the starter clutch as an assembly.*

Make sure the starter driven gear rotates smoothly. The gear should only rotate clockwise and lock up in the other direction.

Remove the starter driven gear and needle bearing.

Check the driven gear boss, sprag clutch and bearing for abnormal wear or damage.

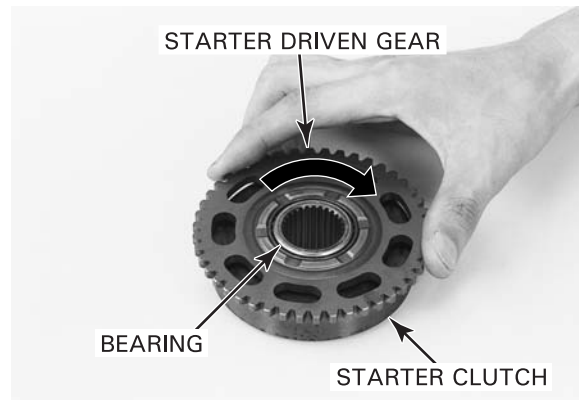

## GEARSHIFT LINKAGE/TRANSMISSION

Remove the following:

- primary driven gear (align the gear teeth of the scissor gears [primary drive gear and sub-gear] by inserting a screwdriver into the gear holes and prying the scissor gear)



- spline washer
- primary drive gear

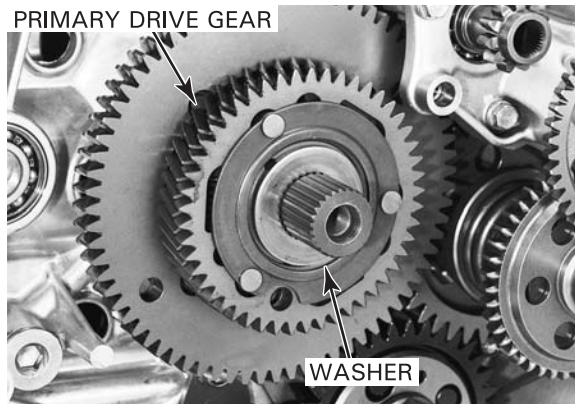

- six bolts
- alternator drive gear



- reverse shifter and shift drum lock arm (page 19-46)
- output shaft assembly

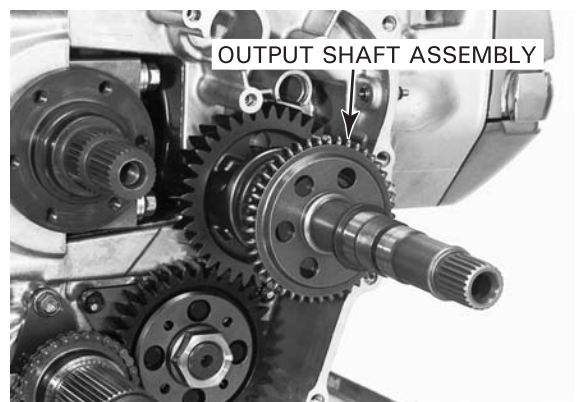



## GEARSHIFT LINKAGE/TRANSMISSION

Temporarily install the clutch outer onto the primary driven gear boss.  
Hold the clutch outer with the special tool and loosen the oil pump driven sprocket bolt.

**TOOL:**

**Clutch outer holder**                      **07JMB-MN50100**

Remove the clutch outer.

Remove the following:

- driven sprocket bolt

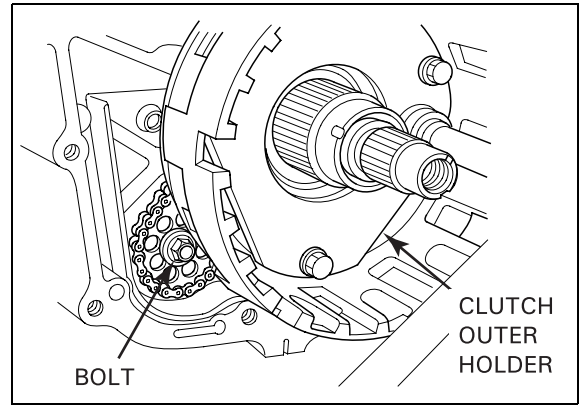

- driven sprocket, drive chain and primary driven gear boss as a set
- two bolts and oil separation plate (if necessary)

Check the driven gear boss bearing for wear or damage.

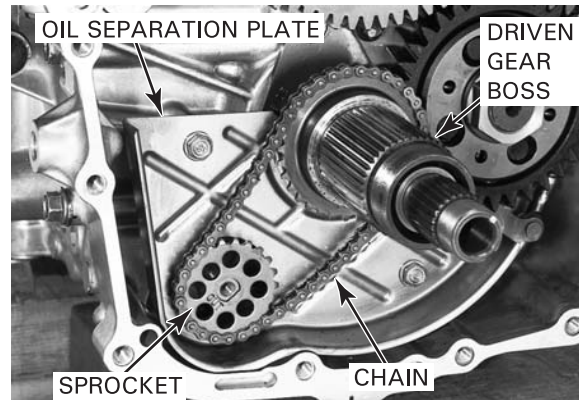

*Be careful not to damage the countershaft threads.*      Unstake the final drive gear lock nut with a drill or grinder.

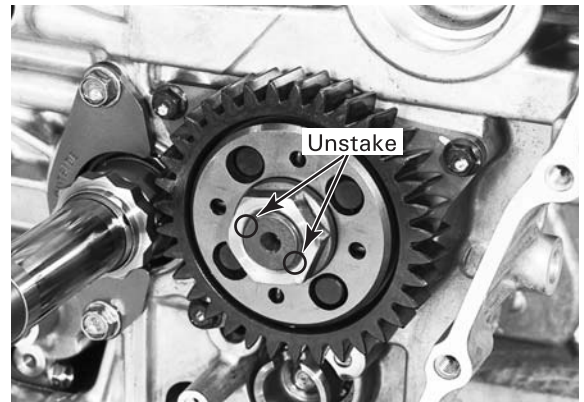

*The final drive gear lock nut has left-hand threads.*      Shift the transmission into any forward gear except neutral.  
Hold the mainshaft with the special tool and loosen the lock nut.

**TOOL:**

**Shaft holder**                                      **07JMB-MN50200**

Remove the following:

- lock nut
- washer
- final drive gear

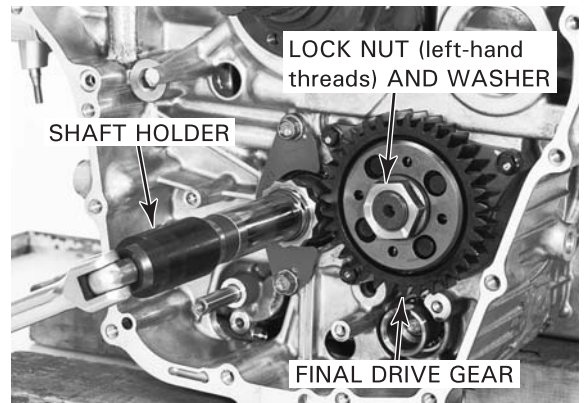

## GEARSHIFT LINKAGE/TRANSMISSION

### DRIVEN GEAR BOSS BEARING REPLACEMENT

Press the needle bearing out of the primary driven gear boss.

**TOOLS:**

<b>Driver</b>	<b>07749-0010000</b>
<b>Attachment, 28 x 30 mm</b>	<b>07946-1870100</b>
<b>Pilot, 28 mm</b>	<b>07746-0041100</b>

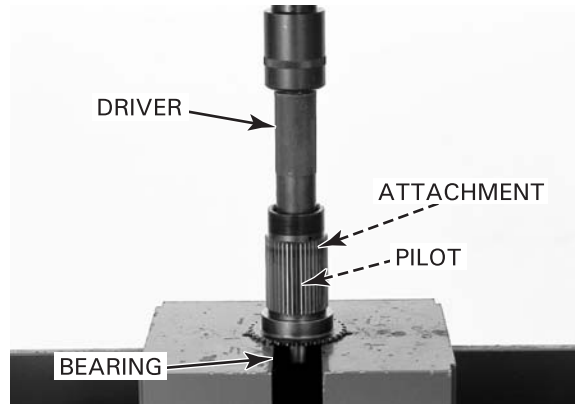

*Install the needle bearing with the stamped side facing up.*

Press a new needle bearing into the driven gear boss until the depth from the outer surface (oil pump drive sprocket) is 3.5 – 4.0 mm (0.14 – 0.16 in) using the special tools.

**TOOLS:**

<b>Driver</b>	<b>07749-0010000</b>
<b>Attachment, 32 x 35 mm</b>	<b>07746-0010100</b>
<b>Pilot, 28 mm</b>	<b>07746-0041100</b>

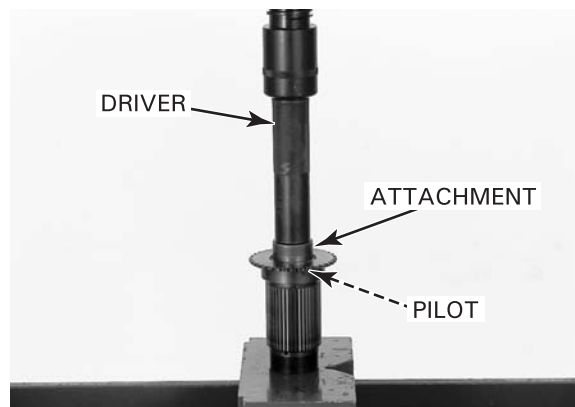

### OUTPUT SHAFT DISASSEMBLY/INSPECTION

Turn the bearing outer race with your finger. The bearing should turn smoothly and quietly.

Remove the following:

- snap ring
- retainer
- cotters

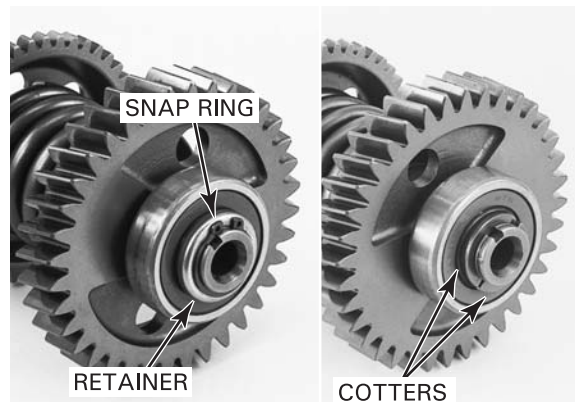

Press the output shaft out of the bearing using a suitable collar (about 20 mm O.D.) and remove the following:

- bearing
- gear bushing
- final driven gear

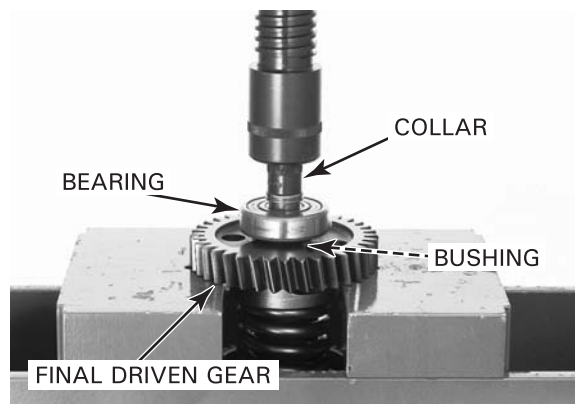

- thrust washer
- damper lifter
- damper spring
- reverse driven gear

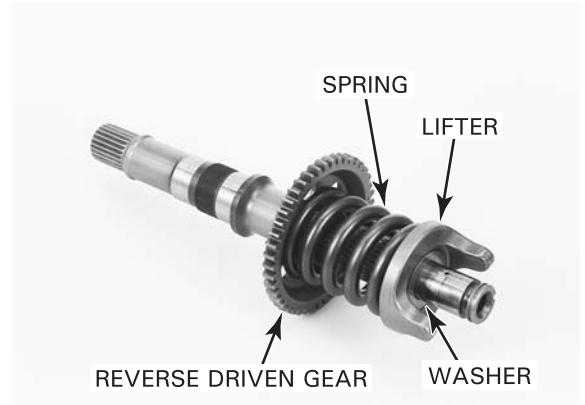

Check the damper lifter for wear or damage.  
Measure the damper spring free length.

**SERVICE LIMIT: 64.0 mm (2.52 in)**

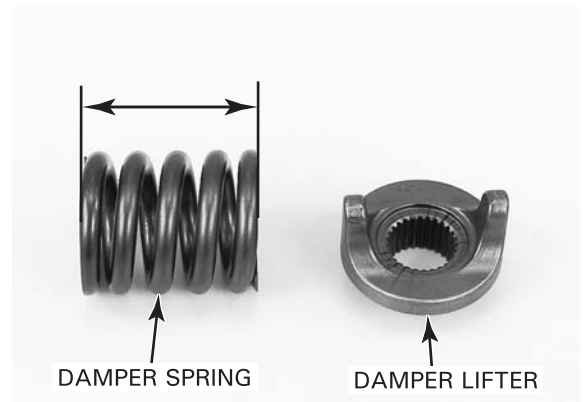

Check the output shaft, gear bushing and final driven gear for abnormal wear or damage.  
Measure the driven gear I.D.

**SERVICE LIMIT: 26.03 mm (1.025 in)**

Measure the bushing O.D. and I.D.

**SERVICE LIMIT: O.D.: 25.95 mm (1.022 in)**  
**I.D.: 22.05 mm (0.868 in)**

Measure the shaft O.D.

**SERVICE LIMIT: 21.99 mm (0.866 in)**



## OUTPUT SHAFT ASSEMBLY

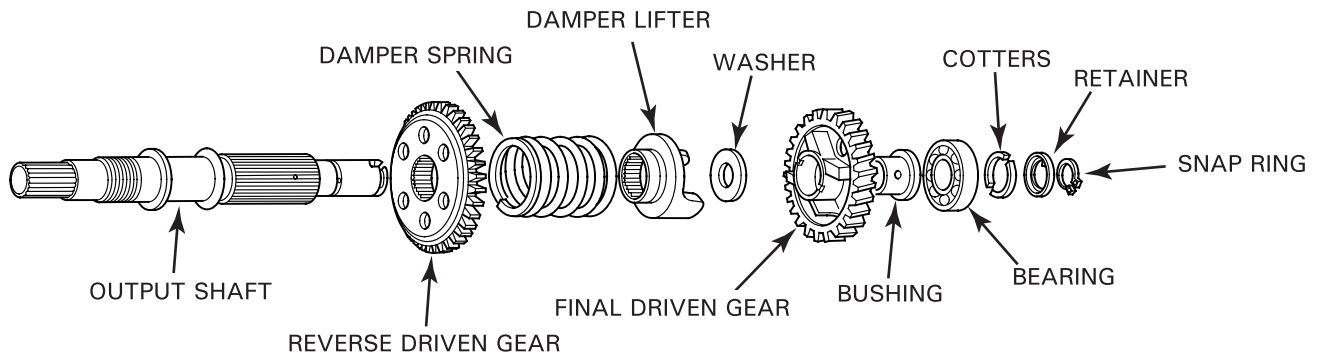

## GEARSHIFT LINKAGE/TRANSMISSION

Install the following onto the output shaft:

- reverse driven gear (with dished side facing spring)
- damper spring
- damper lifter
- thrust washer

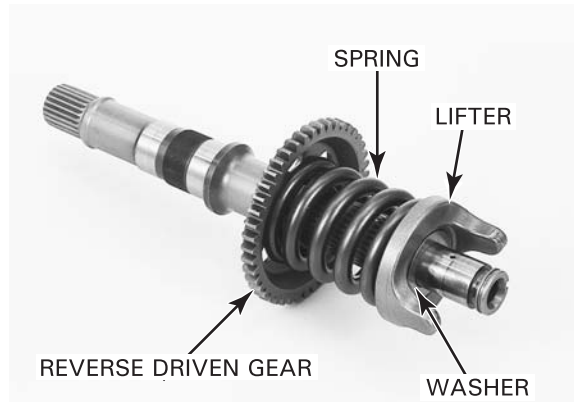

- final driven gear (by aligning its grooves with lifter lugs)
- gear bushing (apply engine oil)

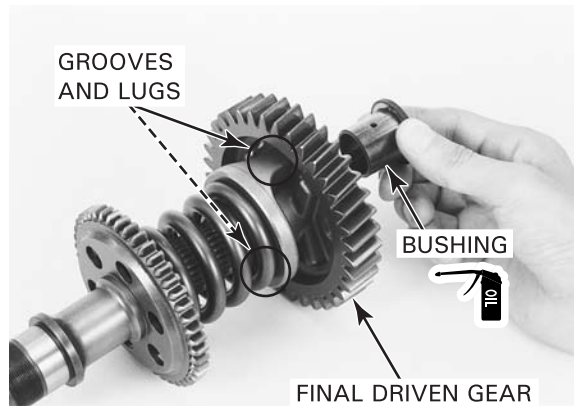

*Install the bearing with the sealed side facing up.*

Press a new bearing onto the output shaft using the special tool.

**TOOL:**

**Driver, 22 mm I.D.**

**07746-0020100**



Install the cotters into the cotter groove. Install the retainer by aligning its tab with the groove in the shaft and turn it to set the tab in the opposite position of the groove. Secure the retainer with the snap ring.

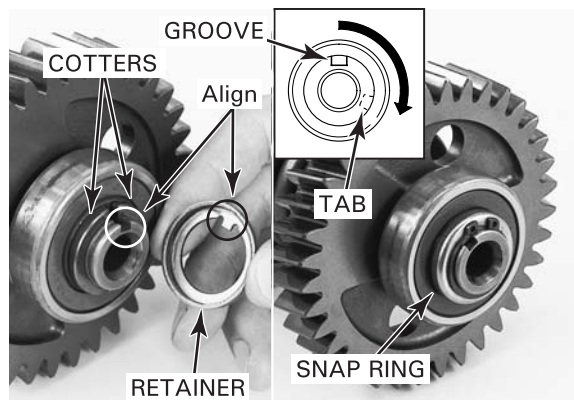

# CRANKCASE COVER BEARING REPLACEMENT

Remove the bolts and bearing setting plates.

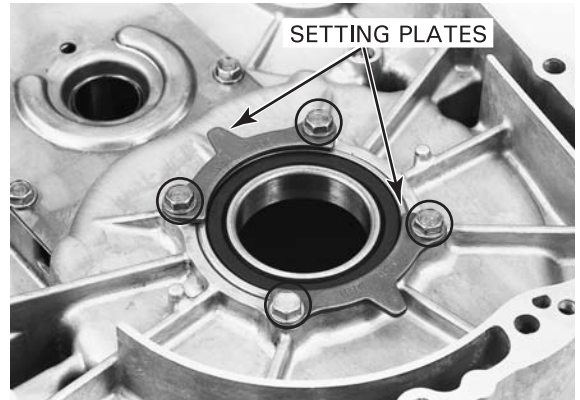

Heat the crankcase cover to 80°C (176°F) and remove the needle bearing of the reverse shifter shaft from the rear crankcase cover using the special tools.  
Drive the other bearings out of the crankcase cover.

**TOOLS:**

- Bearing remover, 12 mm**      **07936-1660110**  
    **07936-1660120** or  
    **07936-166010A**  
    (U.S.A. only)  
    **07741-0010201** or  
    **07936-371020A** or  
    **07936-3710200**  
    (U.S.A. only)
- Remover shaft**
- Remover weight**

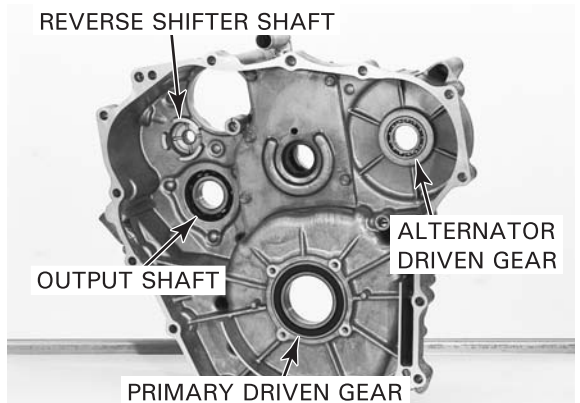

Remove the alternator driven gear bearing from the crankcase.

Drive a new alternator driven gear bearing in the crankcase with the sealed side facing in.

**TOOLS:**

- Driver**      **07749-0010000**
- Attachment, 42 x 47 mm**      **07746-0010300**
- Pilot, 20 mm**      **07746-0040500**

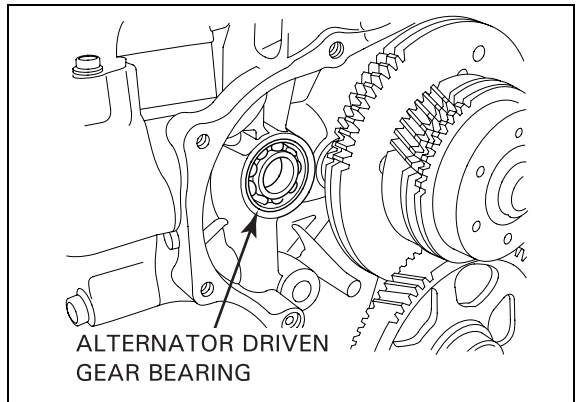

Drive the following bearings into the crankcase cover with the markings facing up. Use new bearings.

**TOOLS:**

- Output shaft:**
- Driver**      **07749-0010000**
- Attachment, 62 x 68 mm**      **07746-0010500**
- Pilot, 30 mm**      **07746-0040700**
- Alternator driven gear:**
- Driver**      **07749-0010000**
- Attachment, 42 x 47 mm**      **07746-0010300**
- Pilot, 25 mm**      **07746-0040600**

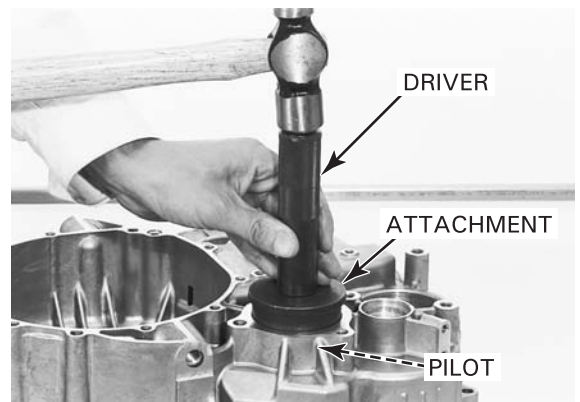

**Reverse shifter shaft:**

- Driver**      **07749-0010000**
- Pilot, 16 mm**      **07746-0041300**



## GEARSHIFT LINKAGE/TRANSMISSION

Drive a new primary driven gear bearing into the crankcase with the sealed side facing up.

### TOOLS:

**Driver** 07749-0010000  
**Attachment, 78 x 90 mm** 07GAD-SD40101

Apply locking agent to the threads of the setting plate bolts.

Install the bearing setting plates with the "OUT SIDE" mark facing up and tighten the bolts.

**TORQUE: 12 N·m (1.2 kgf·m, 9 lbf·ft)**

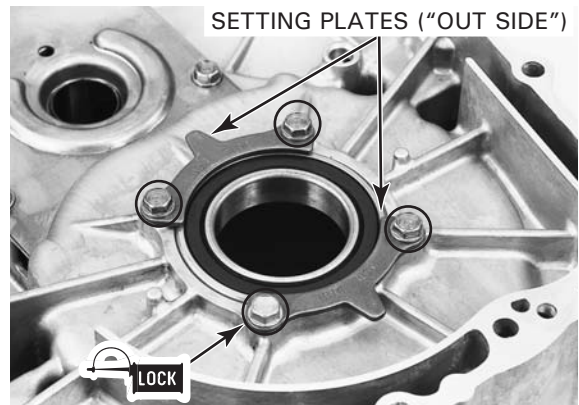

## PRIMARY GEARS/OUTPUT SHAFT INSTALLATION

Apply engine oil to the gear teeth and sliding surface.

Install the final drive gear and lock washer onto the countershaft with the "OUTSIDE" mark on the washer facing out.



*The final drive gear lock nut has left-hand threads.*

Apply engine oil to the threads and seating surface of a new lock nut and install it. Hold the mainshaft with the special tool and tighten the lock nut.

### TOOL:

**Shaft holder** 07JMB-MN50200

**TORQUE: 186 N·m (19.0 kgf·m, 137 lbf·ft)**

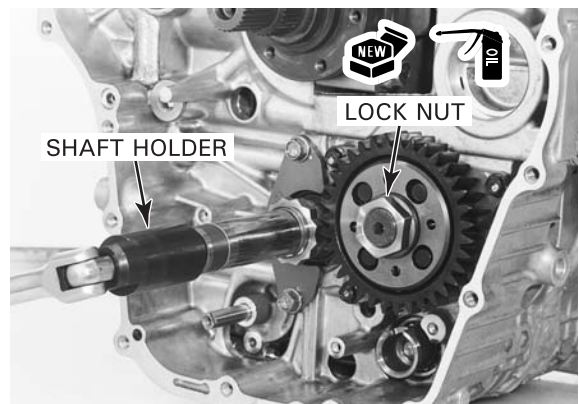



## GEARSHIFT LINKAGE/TRANSMISSION

*Be careful not to damage the countershaft threads.* Stake the lock nut into the countershaft groove in two places.

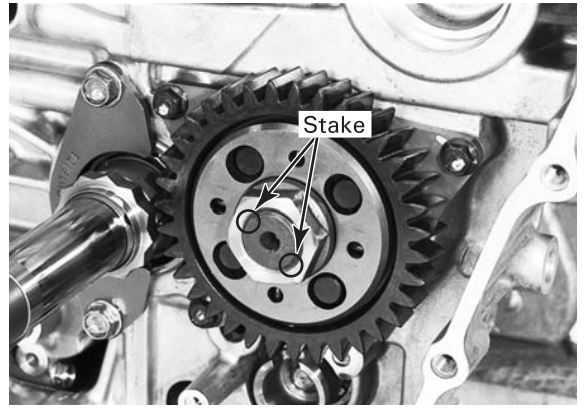

Install the oil separate plate and tighten the two bolts.

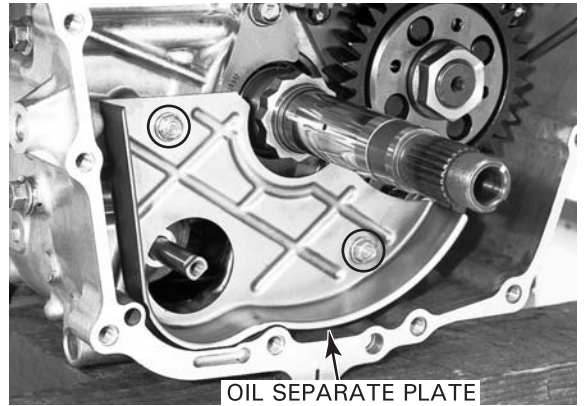

Apply engine oil to the needle bearing in the primary driven gear boss. Install the oil pump driven sprocket, drive chain and driven gear boss as a set with the "OUT" mark of the sprocket facing out.

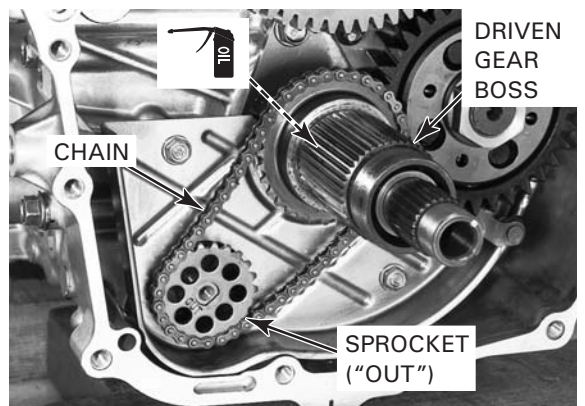

Apply locking agent to the threads of the driven sprocket bolt and install it.

Temporarily install the clutch outer on the driven gear boss. Hold the clutch outer with the special tool and tighten the sprocket bolt.

**TOOL:**

**Clutch outer holder** 07JMB-MN50100

**TORQUE: 18 N·m (1.8 kgf·m, 13 lbf·ft)**

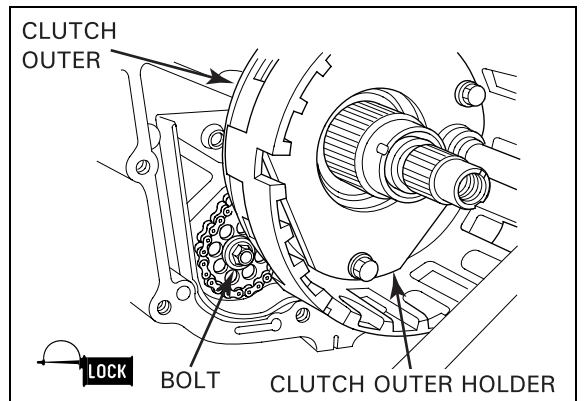

## GEARSHIFT LINKAGE/TRANSMISSION

Install the output shaft assembly onto the crankcase.

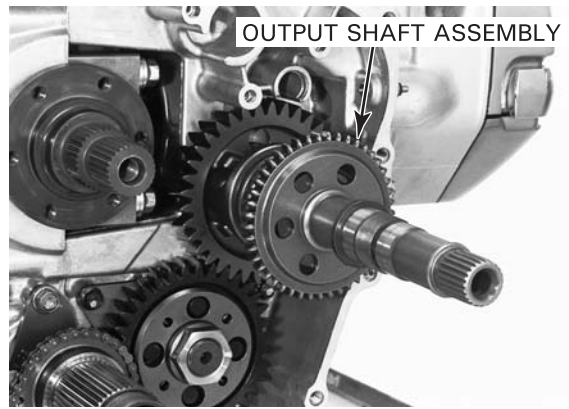

Install the alternator drive gear by aligning the bolt holes in the crankshaft and gear.

Apply engine oil to the threads and seating surface of the drive gear bolts and install them. Remove the timing hole cap and hold the ignition pulse generator bolt which is located on the opposite side of the crankcase and tighten the bolts.

**TORQUE: 25 N·m (2.6 kgf·m, 19 lbf·ft)**

Install the shift drum lock arm and reverse shifter (page 19-43).



Install the primary drive gear and spline washer.



Install the primary driven gear with the long boss side facing out while aligning the scissors gears (primary drive gear and sub-gear) by inserting the screwdriver into the gear holes.



## GEARSHIFT LINKAGE/TRANSMISSION

Apply engine oil to the needle bearing and sprag clutch contacting surfaces.  
Install the bearing and the starter driven gear while turning gear clockwise.

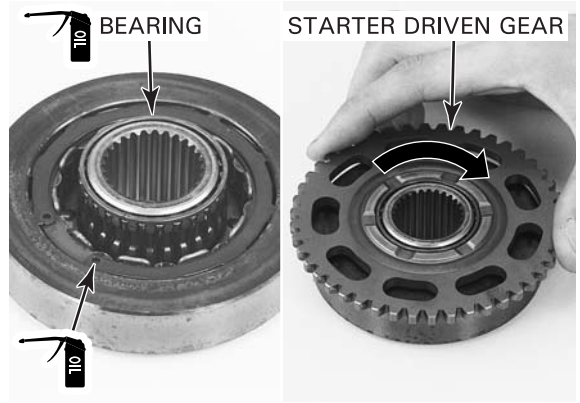

*The final starter clutch bolt has left-hand threads.* Install the starter clutch assembly, washer and bolt.

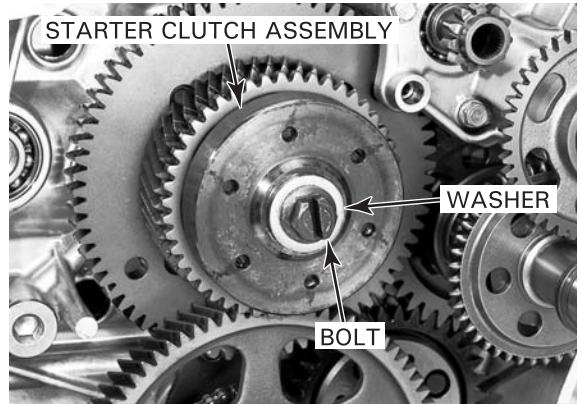

Temporarily install the clutch outer on the primary driven gear boss.  
Hold the clutch outer with the special tool and tighten the starter clutch bolt.

**TOOL:**  
**Clutch outer holder**                      **07JMB-MN50100**

**TORQUE: 74 N·m (7.5 kgf·m, 54 lbf·ft)**

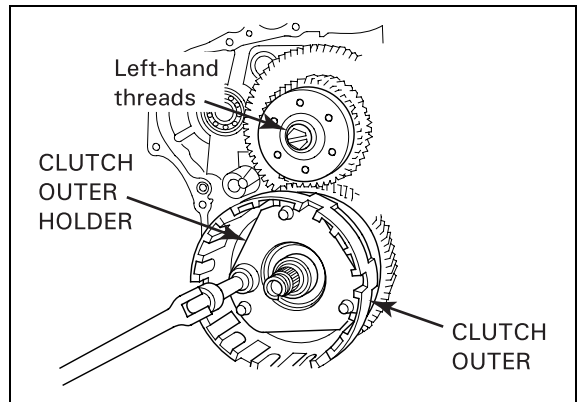

Install the alternator driven gear assembly while aligning the scissors gears (alternator drive gear and sub-gear) by inserting the screwdriver into the gear holes.

Install the friction spring and washer with the concave side of the spring facing in.

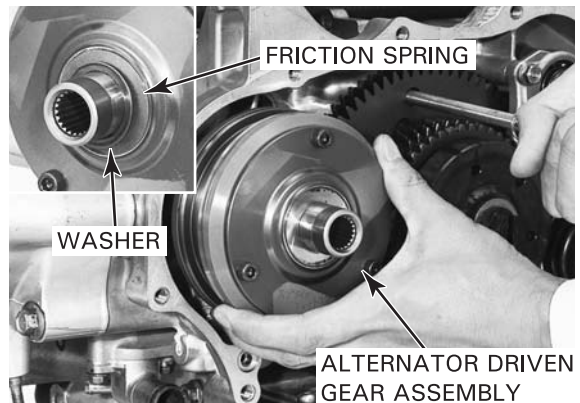



## GEARSHIFT LINKAGE/TRANSMISSION

Apply molybdenum oil solution to the outer surface of the reduction gear shaft.  
Install the starter reduction gear and shaft with the large gear side facing out.

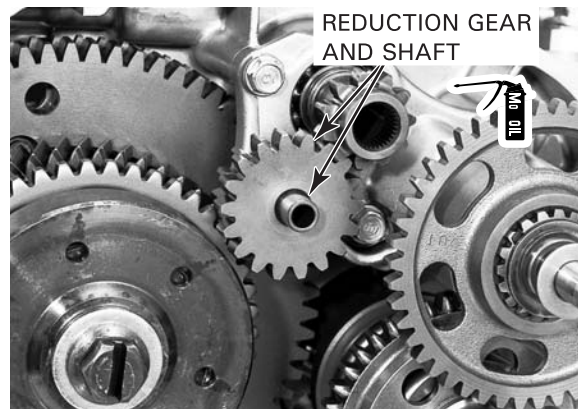

## REAR CRANKCASE COVER INSTALLATION

Clean the gasket mating surfaces of the crankcase cover and crankcase thoroughly, being careful not to damage them.

Install the orifice into the crankcase.  
Coat a new O-ring with engine oil and install it.

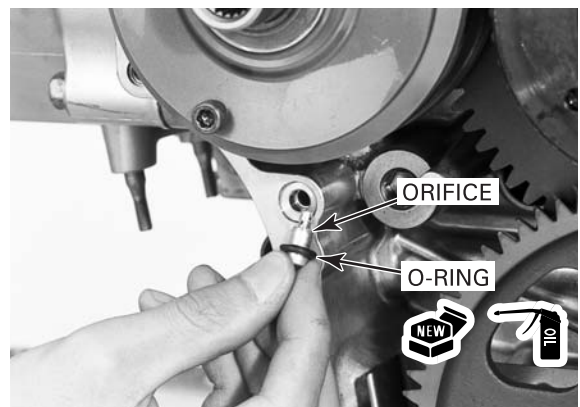

Install the two dowel pins.

Apply sealant to the mating areas of the crankcase as shown.

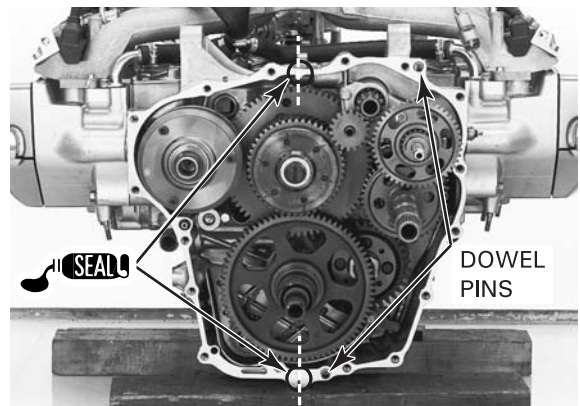

Install a new gasket.

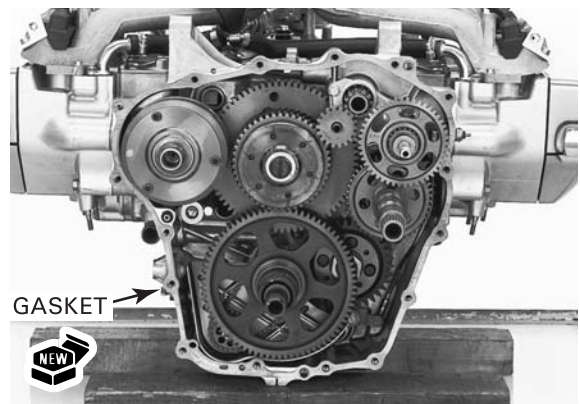

Coat a new O-ring with engine oil and install it into the groove in the clutch regulator valve.  
Install the regulator valve into the crankcase cover.

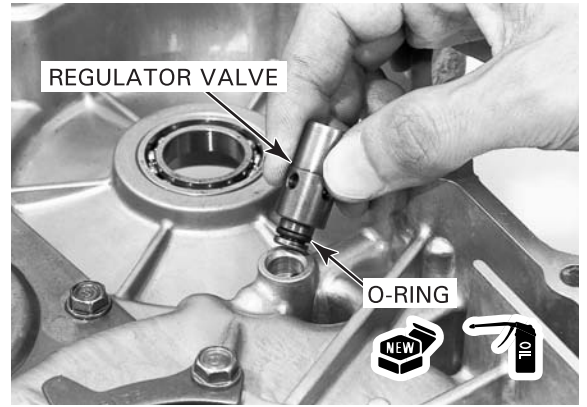

Install the crankcase cover onto the crankcase.  
Install the 16 cover bolts and tighten them in a criss-cross pattern in several steps.



**TORQUE: 24 N-m (2.4 kgf-m, 17 lbf-ft)**

Install a new output shaft lock nut.

Shift the transmission into any gear except neutral.  
Hold the output shaft and tighten the lock nut using the special tools.

**TOOLS:**

**Shaft holder**

**07PAB-0010200 or  
079249-PJ40001  
(U.S.A. only)**

**Lock nut wrench, 30 x 64 mm**

**07916-MB00002 or  
07916-MB00001**

**TORQUE: Actual: 186 N-m (19.0 kgf-m, 137 lbf-ft)  
Indicated: 170 N-m (17.3 kgf-m, 125 lbf-ft)**

*Refer to torque wrench reading information on page 10-4 "Service Information."*

*Be careful not to damage the output shaft threads.*

Stake the lock nut into the output shaft groove.

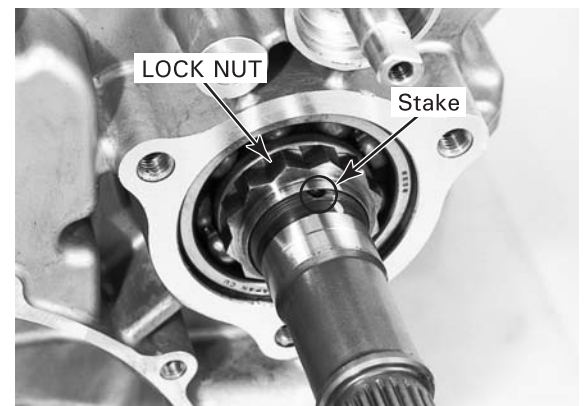
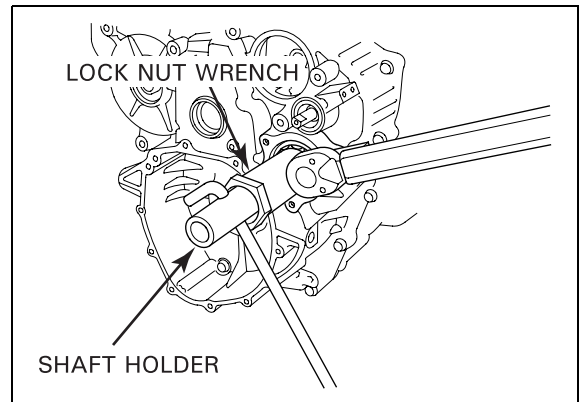

## GEARSHIFT LINKAGE/TRANSMISSION

Install a new oil seal until it is fully seated.

### TOOLS:

**Driver** 07749-0010000  
**Attachment, 42 x 47 mm** 07746-0010300

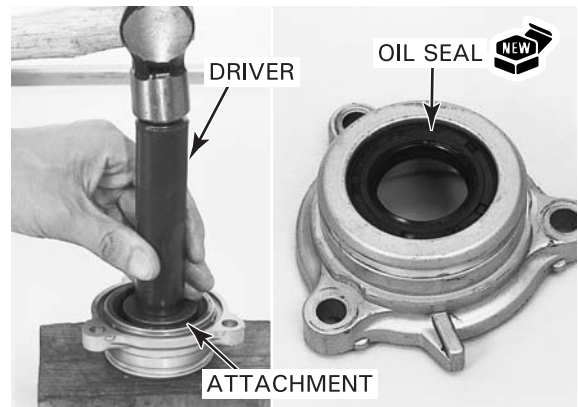

Coat a new O-ring with engine oil and install it into the bearing holder groove.

Pack grease into the oil seal lip cavity and install the bearing holder, being careful not to damage the seal lips.

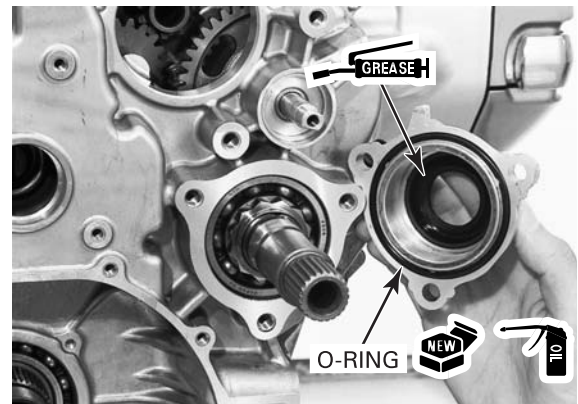

Install the three bolts and tighten them.

**TORQUE: 28 N·m (2.9 kgf·m, 21 lbf·ft)**

Install the following:

- clutch (page 9-20)
- water pump (page 6-18)
- alternator (page 17-18)
- starter/reverse motor (page 19-17)
- reverse shift arm/cables (page 19-49)
- engine (section 7)

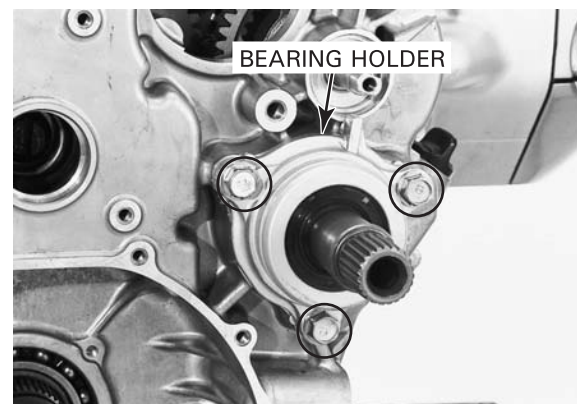

## TRANSMISSION DISASSEMBLY

Separate the crankcase (page 11-6).

### RIGHT CRANKCASE

#### SHIFT FORK AND SHIFT DRUM:

Remove the following:

- two bolts
- shift drum setting plate

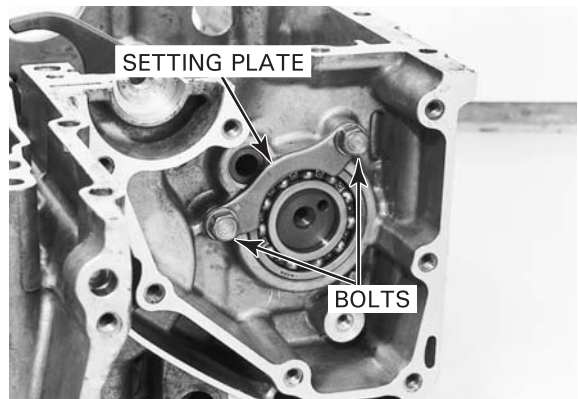



## GEARSHIFT LINKAGE/TRANSMISSION

- fork shaft
- shift forks

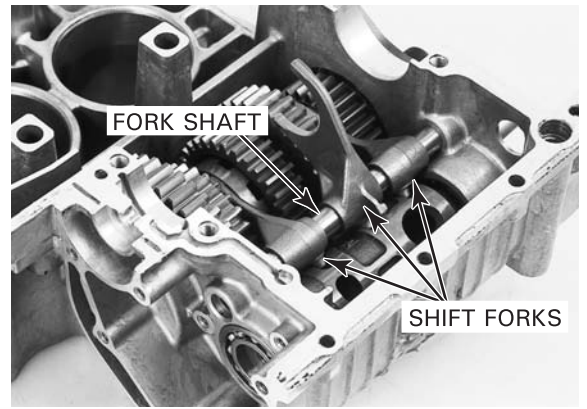

- shift drum assembly

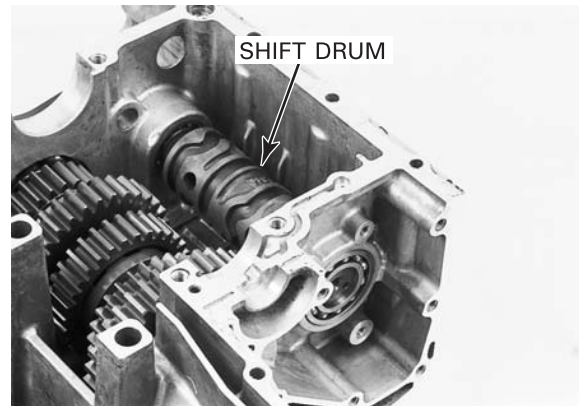

### COUNTERSHAFT:

Remove the three bolts and countershaft setting plate.

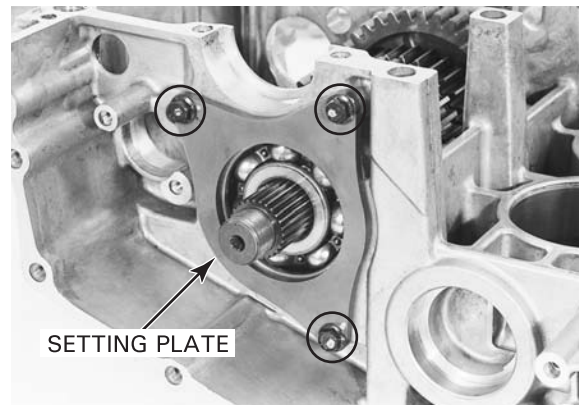

Slide the countershaft off the crankcase and remove the rear side bearing.

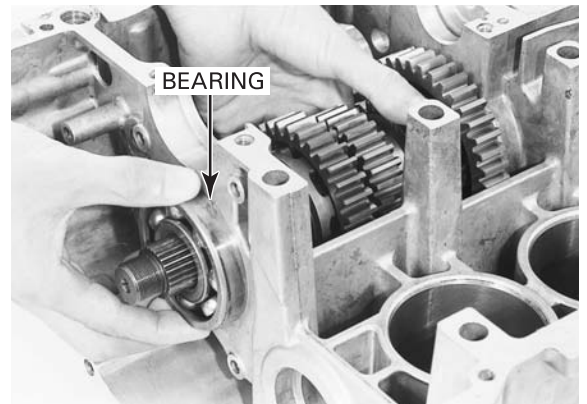

## GEARSHIFT LINKAGE/TRANSMISSION

Remove the C1 gear (front end gear) to avoid interference with the crankcase.  
Remove the countershaft assembly out of the crankcase.

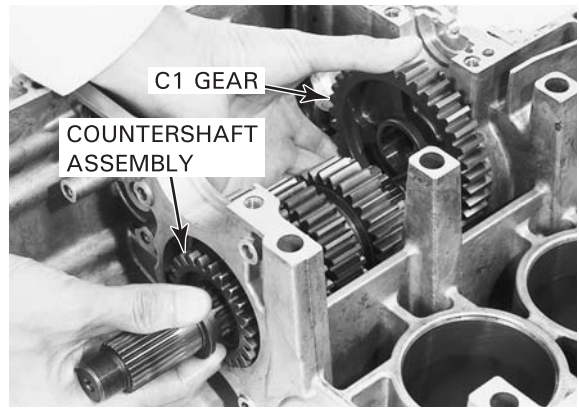

Remove the front side bearing and oil pass plate.  
Disassemble the countershaft.  
Clean all disassembled parts in solvent thoroughly.

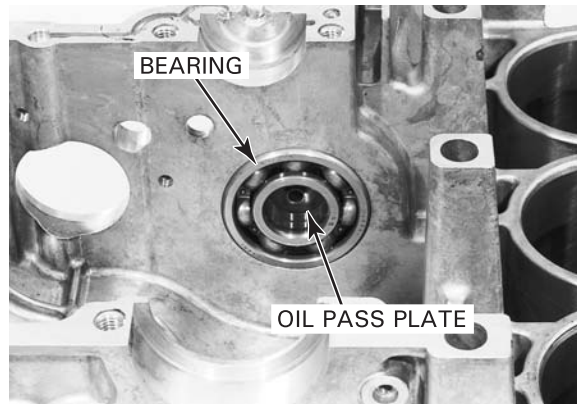

### LEFT CRANKCASE

#### MAINSHAFT:

Remove the following:

- two bolts
- mainshaft setting plate

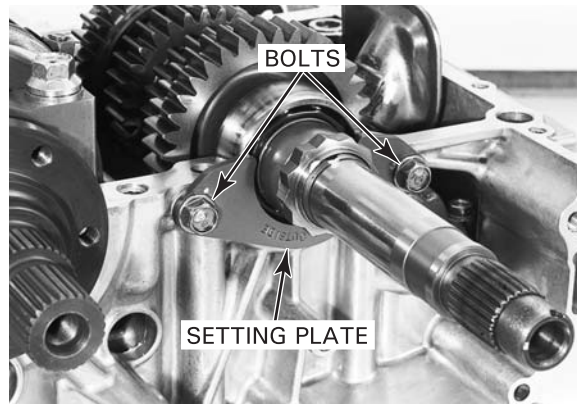

- mainshaft assembly
- dowel pin

Disassemble the mainshaft.

Clean all disassembled parts in solvent thoroughly.

Check the needle bearing for abnormal wear or damage.

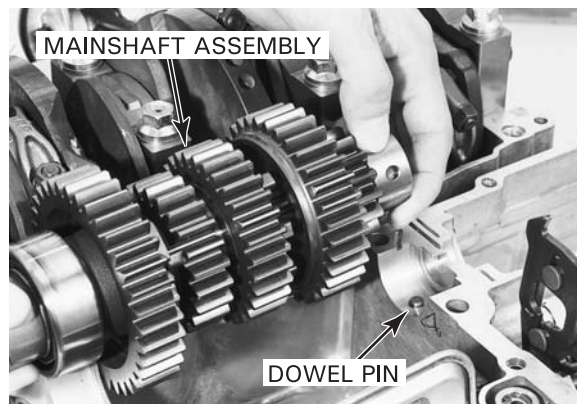

### GEARSHIFT SPINDLE:

Remove the following:

- bolt and lock washer (straighten washer tabs)
- gearshift spindle B
- thrust washer
- spindle arm

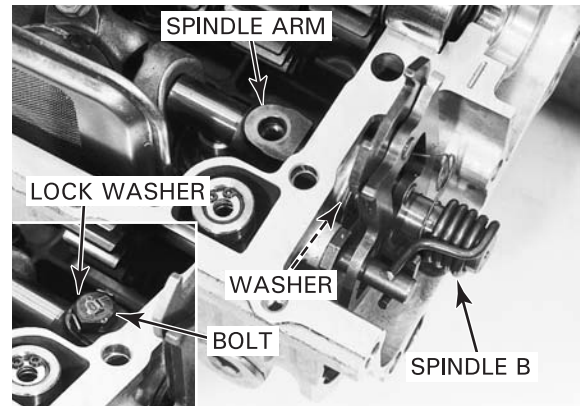

- gearshift spindle A
- oil seal

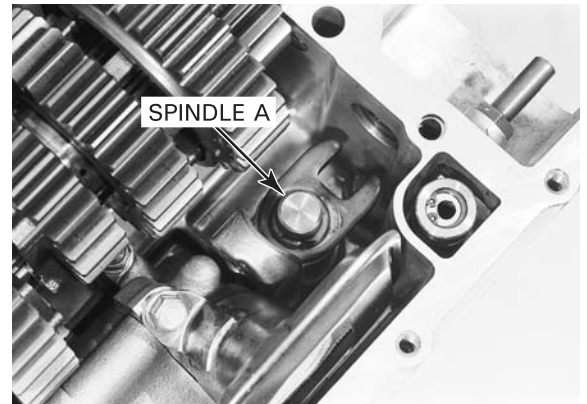

### INSPECTION

Check the gearshift spindles for bends.  
Check the spindle arm and spindle plates for wear or damage.  
Check the spindle return spring for fatigue or damage.

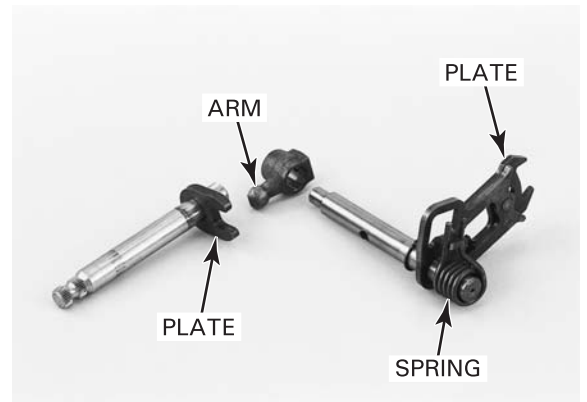

Check the shift fork guide pins for abnormal wear or damage.

Measure the shift fork I.D.

**SERVICE LIMIT: 14.04 mm (0.553 in)**

Measure the shift fork claw thickness.

**SERVICE LIMIT: 5.6 mm (0.22 in)**

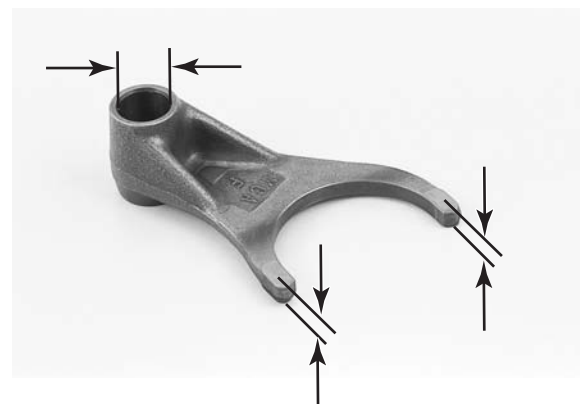

## GEARSHIFT LINKAGE/TRANSMISSION

Measure the shift fork shaft O.D.

**SERVICE LIMIT: 13.90 mm (0.547 in)**

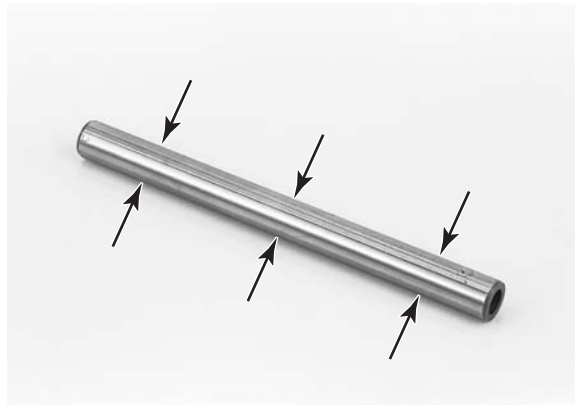

Check the shift drum guide grooves and reverse lock cam for abnormal wear or damage.

Check the shift drum bearings for smooth rotation.

Remove the following and replace any faulty part if necessary:

- front side bearing
- bolt
- reverse lock cam
- dowel pin
- rear side bearing

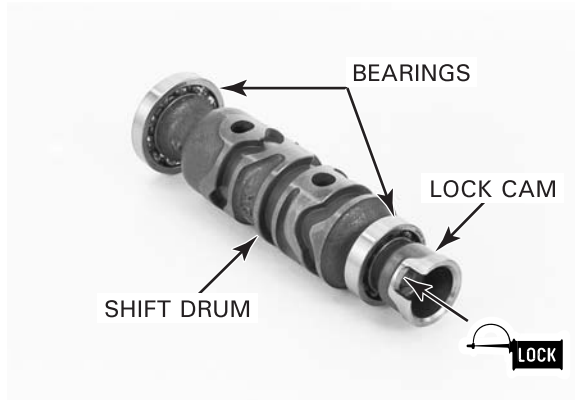

Install the front side bearing.

Install the dowel pin and the lock cam by aligning the hole in the lock cam with the dowel pin.

Apply locking agent to the lock cam bolt threads. Install the bolt and tighten it.

**TORQUE: 12 N·m (1.2 kgf·m, 9 lbf·ft)**

Install the rear side bearing.

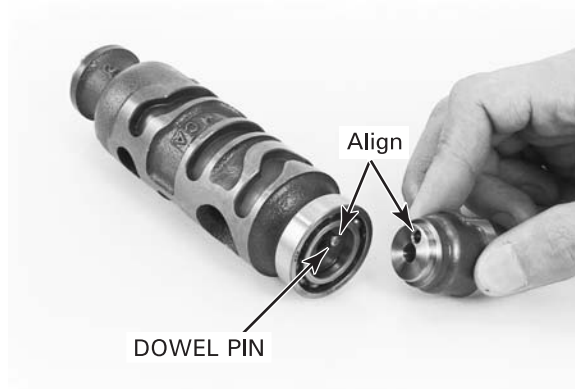

Check the gear shifter groove for abnormal wear or damage. Check the gear dogs and teeth for abnormal wear or damage.

If there is damage to the gear dogs, check the slots or dogs on the corresponding engagement gear for damage.



Measure the gear I.D.

**SERVICE LIMITS:**

**M4: 31.04 mm (1.222 in)**

**M5: 35.04 mm (1.380 in)**

**C2, C3: 33.04 mm (1.301 in)**

Measure the gear bushing O.D.

**SERVICE LIMITS:**

**M4: 30.93 mm (1.218 in)**

**M5: 34.93 mm (1.375 in)**

**C2, C3: 32.93 mm (1.296 in)**

Calculate the gear-to-bushing clearance.

**SERVICE LIMITS: 0.10 mm (0.004 in)**

Measure the gear bushing I.D.

**SERVICE LIMITS:**

**M4: 28.04 mm (1.104 in)**

**M5: 32.04 mm (1.261 in)**

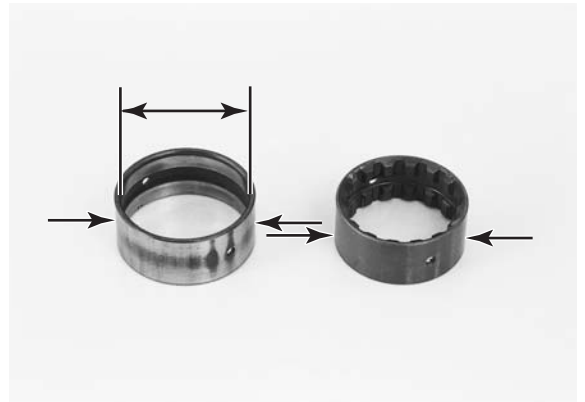

Check the mainshaft and countershaft for abnormal wear or damage.

Measure the mainshaft O.D. at the M4 and M5 gears.

**SERVICE LIMITS:**

**M4: 27.96 mm (1.101 in)**

**M5: 31.96 mm (1.258 in)**

Calculate the gear bushing-to-shaft clearance.

**SERVICE LIMIT: 0.08 mm (0.003 in)**



Turn the ball bearing race with your finger. The bearing should turn smoothly and quietly.

Replace the bearing if the race does not turn smoothly or quietly.





## GEARSHIFT LINKAGE/TRANSMISSION

### MAINSHAFT BEARING REPLACEMENT

*Be careful not to damage the mainshaft threads.*

Unstake the lock nut with a drill or grinder.

Hold the mainshaft and loosen the lock nut using the special tools and a breaker bar.

#### TOOLS:

**Shaft holder** 07JMB-MN50200  
07916-MB00002 or  
07916-MB00001

**Lock nut wrench, 30 x 64 mm** 07916-MB00001

Remove the following:

- lock nut
- collar

Press the mainshaft out of the bearing.

Press a new bearing onto the mainshaft using the special tools.

#### TOOLS:

**Driver, 40 mm I.D.** 07746-0030100  
**Attachment, 30 mm I.D.** 07746-0030300

Apply engine oil to the threads of a new lock nut.

Install the collar and the lock nut.

Hold the mainshaft and tighten the lock nut using the special tools.

#### TOOLS:

**Shaft holder** 07JMB-MN50200  
07916-MB00002 or  
07916-MB00001

**TORQUE: Actual: 186 N·m (19.0 kgf·m, 137 lbf·ft)**  
**Indicated: 170 N·m (17.3 kgf·m, 125 lbf·ft)**

*Refer to torque wrench reading information on page 10-4 "Service Information."*

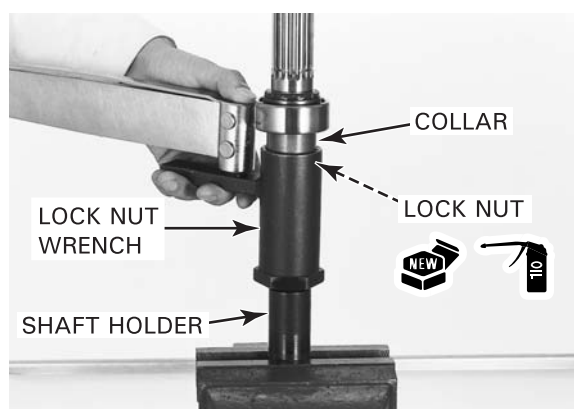
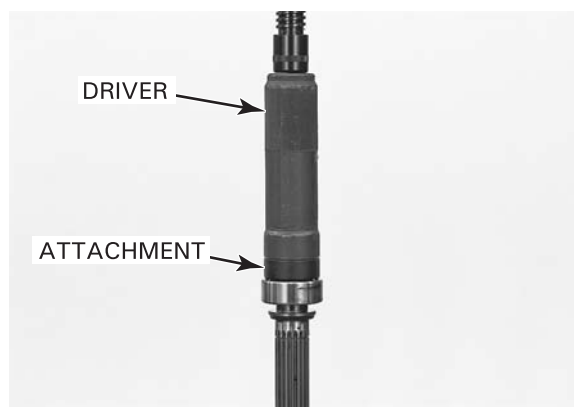
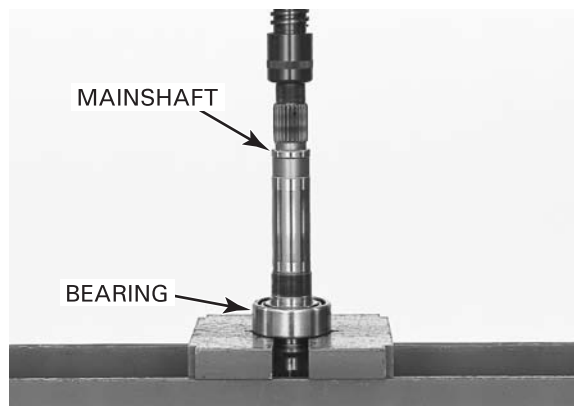
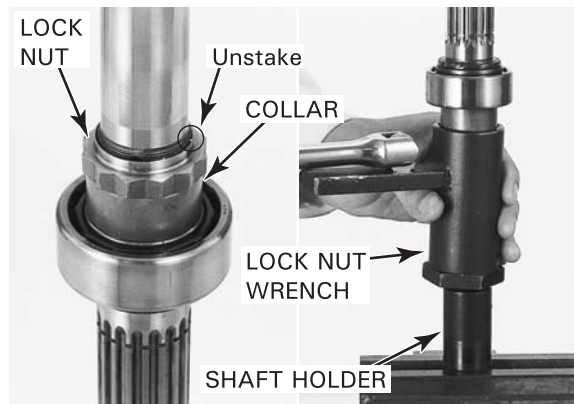



*Be careful not to damage the mainshaft threads.* Stake the lock nut into the mainshaft groove.



## TRANSMISSION ASSEMBLY

**NOTE:**

- Align the lock washer tabs with the splined washer grooves.
- Always install the thrust washer and snap ring with the chamfered (rolled) edge facing away from the thrust load (see the illustration on page 10-34).



- Install the snap ring so its end gap aligns with the groove in the splines (page 10-33).
- Make sure the snap ring is fully seated in the shaft groove after installing it.

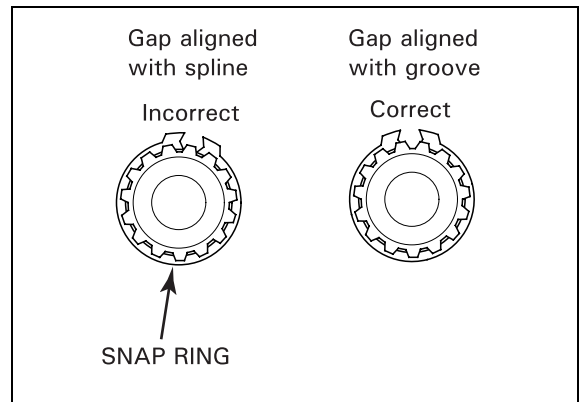

# GEARSHIFT LINKAGE/TRANSMISSION

## COUNTERSHAFT ASSEMBLY

Apply engine oil to the gear teeth, sliding surfaces, bushings and bearing.

Apply molybdenum oil solution to the gear shifter grooves.

Assemble the countershaft except the C1 gear (front end gear).

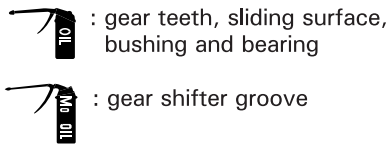
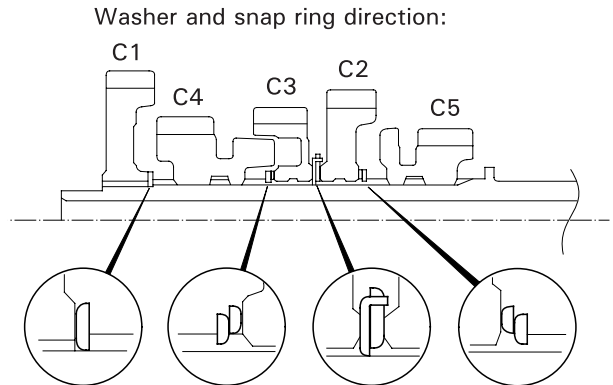
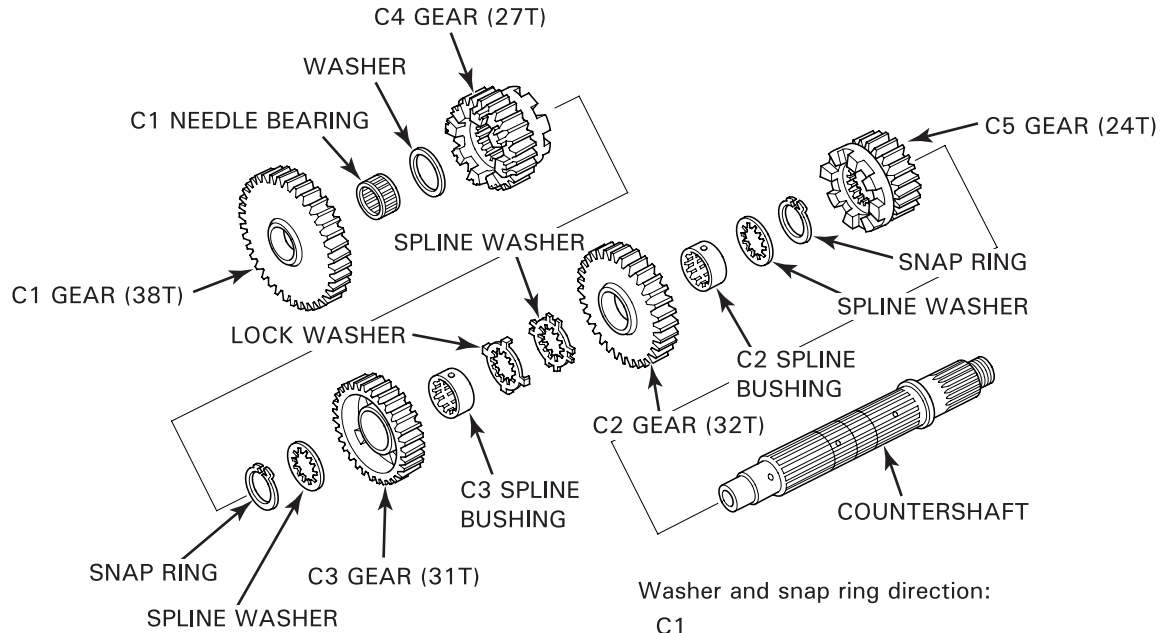

Install the oil pass plate and front side bearing into the right crankcase.

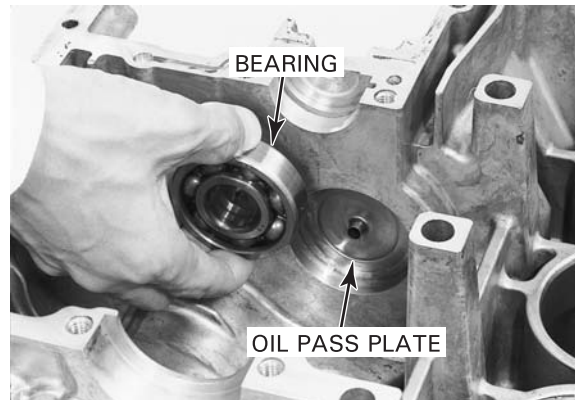

Insert the countershaft assembly into the hole (bearing support) in the crankcase and support it, being careful not to damage the gear teeth.

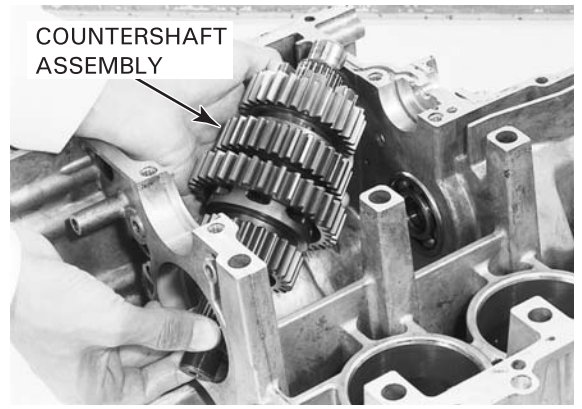

Install the C1 gear onto the countershaft. Install the countershaft assembly into the bearing in the crankcase.

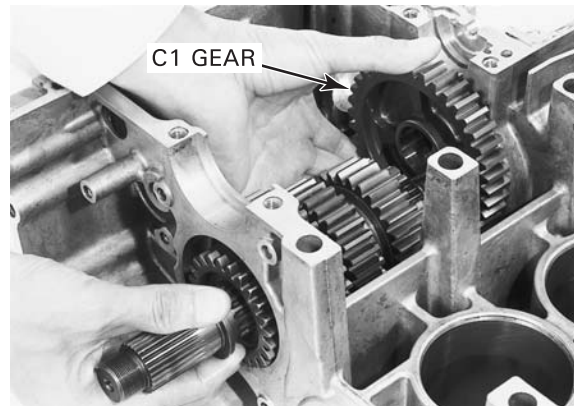

Support the countershaft assembly and install the rear side bearing onto the countershaft and into the crankcase.

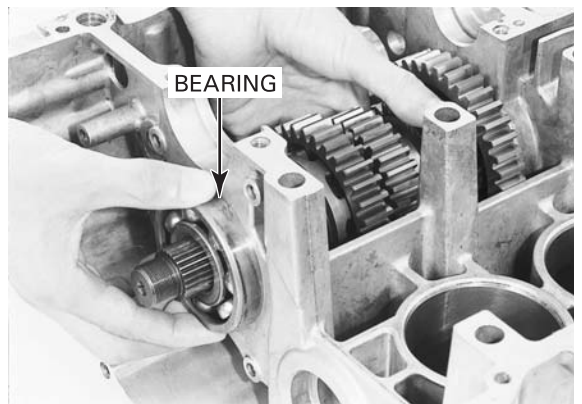

Apply locking agent to the setting plate bolt threads. Install the setting plate and tighten the three bolts.

**TORQUE: 12 N·m (1.2 kgf·m, 9 lbf·ft)**

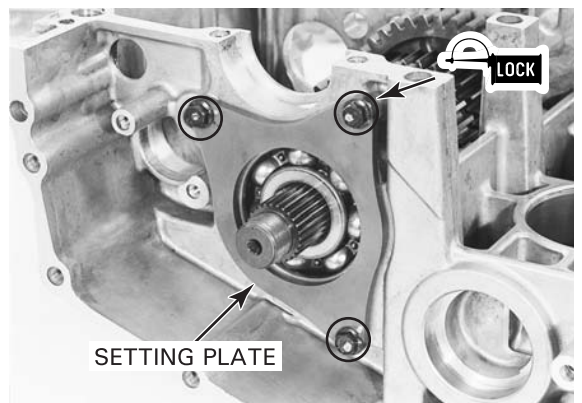

## GEARSHIFT LINKAGE/TRANSMISSION

### SHIFT DRUM AND SHIFT FORK ASSEMBLY

Install the shift drum assembly from the front side of the crankcase to seat its bearings into the bearing supports properly.

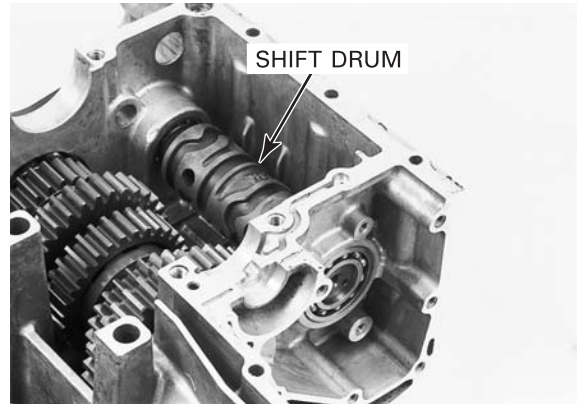

The shift forks have the following identification marks:

F: front shift fork  
C: center shift fork  
R: rear shift fork

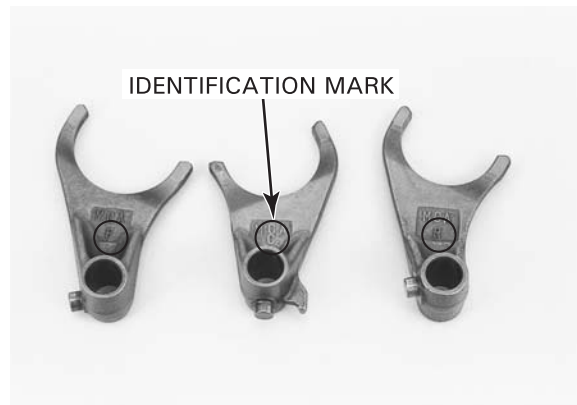

Apply engine oil to the outer surface of the shift fork shaft.

Install the shift forks into the gear shifter grooves (front and rear forks) and into the shift drum guide grooves with the identification marks facing toward the front side of the engine, then insert the fork shaft.

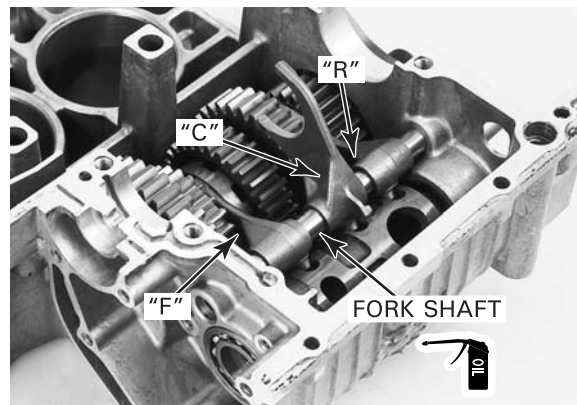

Apply locking agent to the setting plate bolt threads. Install the setting plate and tighten the two bolts.

**TORQUE: 12 N·m (1.2 kgf·m, 9 lbf·ft)**

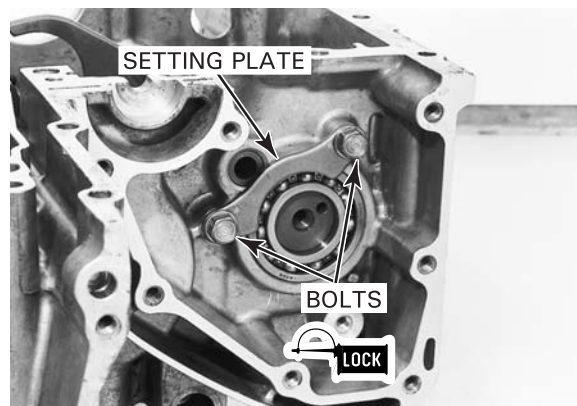

**MAINSHAFT ASSEMBLY**

Apply engine oil to the gear teeth, sliding surfaces, bushings and bearing.

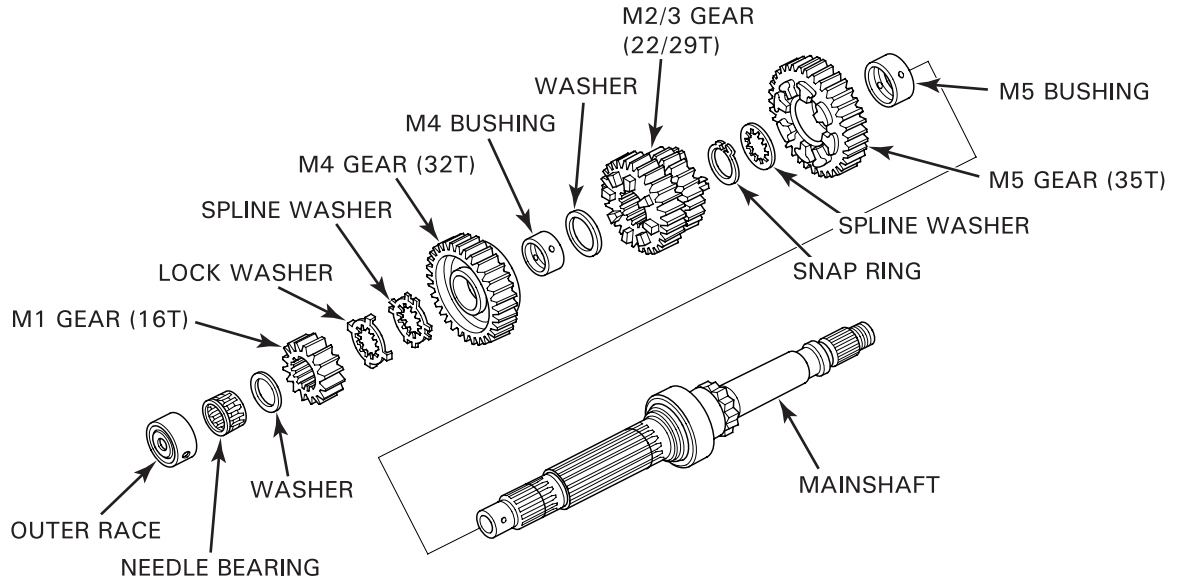

Apply molybdenum oil solution to the gear shifter groove.

See NOTE on page 10-33. Assemble the mainshaft.

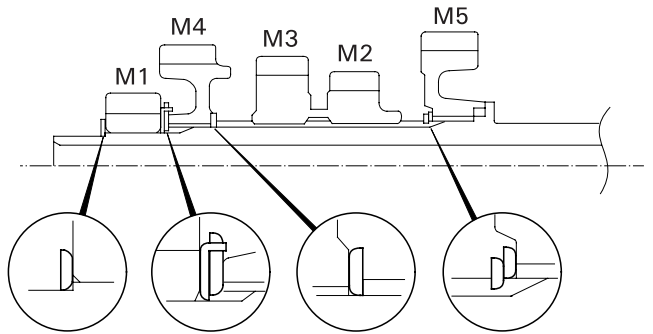

Washer and snap ring direction:



-  : gear teeth, sliding surface, bushing and bearing
-  : gear shifter groove

Install the dowel pin into the crankcase.  
Install the mainshaft assembly by properly aligning the hole in the needle bearing with the dowel pin.

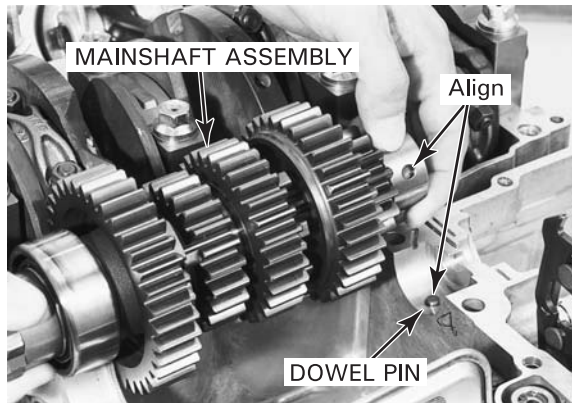



## GEARSHIFT LINKAGE/TRANSMISSION

Apply locking agent to the setting plate bolt threads. Install the setting plate with the "OUTSIDE" mark facing out and tighten the two bolts.

**TORQUE: 26 N·m (2.7 kgf·m, 20 lbf·ft)**

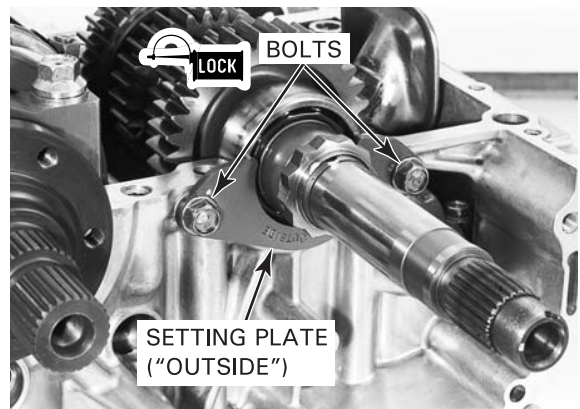

### GEARSHIFT SPINDLE ASSEMBLY

Apply engine oil to the needle bearings (four places).

Pack grease into the seal lip cavity of a new oil seal and install it into the crankcase.

Install gearshift spindle A, being careful not to damage the oil seal lips.

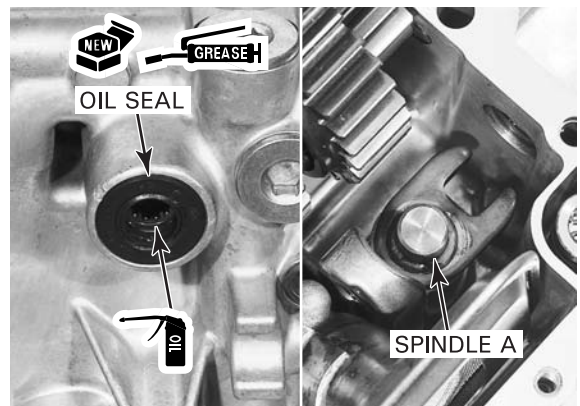

Install the thrust washer onto gearshift spindle B.

Place the spindle arm through the notch in spindle A with the flat surface of the arm facing in. Then insert spindle B through the crankcase and spindle A, align the spring ends with the spring pin.

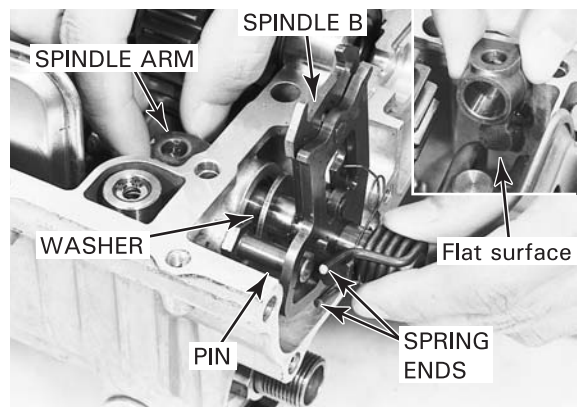

Align the bolt holes in the spindle arm and spindle B, and install a new lock washer and the bolt. Tighten the bolt.

**TORQUE: 25 N·m (2.5 kgf·m, 18 lbf·ft)**

Bend the lock tabs up against the bolt head.

Assemble the crankcase halves (page 11-22).

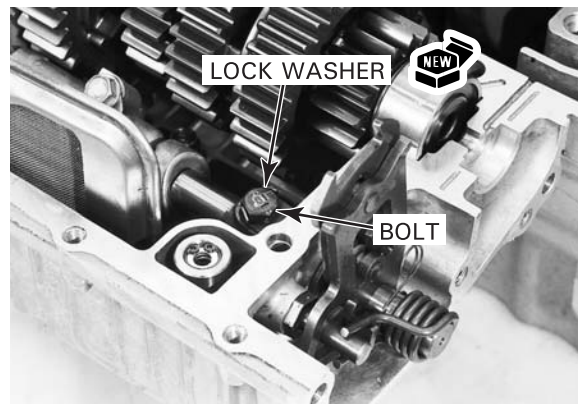



# 11. CYLINDER/PISTON/CRANKSHAFT

---

COMPONENT LOCATION .....	11-2	CRANKSHAFT REMOVAL.....	11-13
SERVICE INFORMATION .....	11-3	MAIN JOURNAL BEARING.....	11-14
TROUBLESHOOTING .....	11-5	CRANKSHAFT INSTALLATION .....	11-16
CRANKCASE SEPARATION.....	11-6	PISTON/CONNECTING ROD INSTALLATION.....	11-17
PISTON/CONNECTING ROD REMOVAL ...	11-7	CRANKCASE ASSEMBLY .....	11-22
CRANKPIN BEARING .....	11-11		

COMPONENT LOCATION

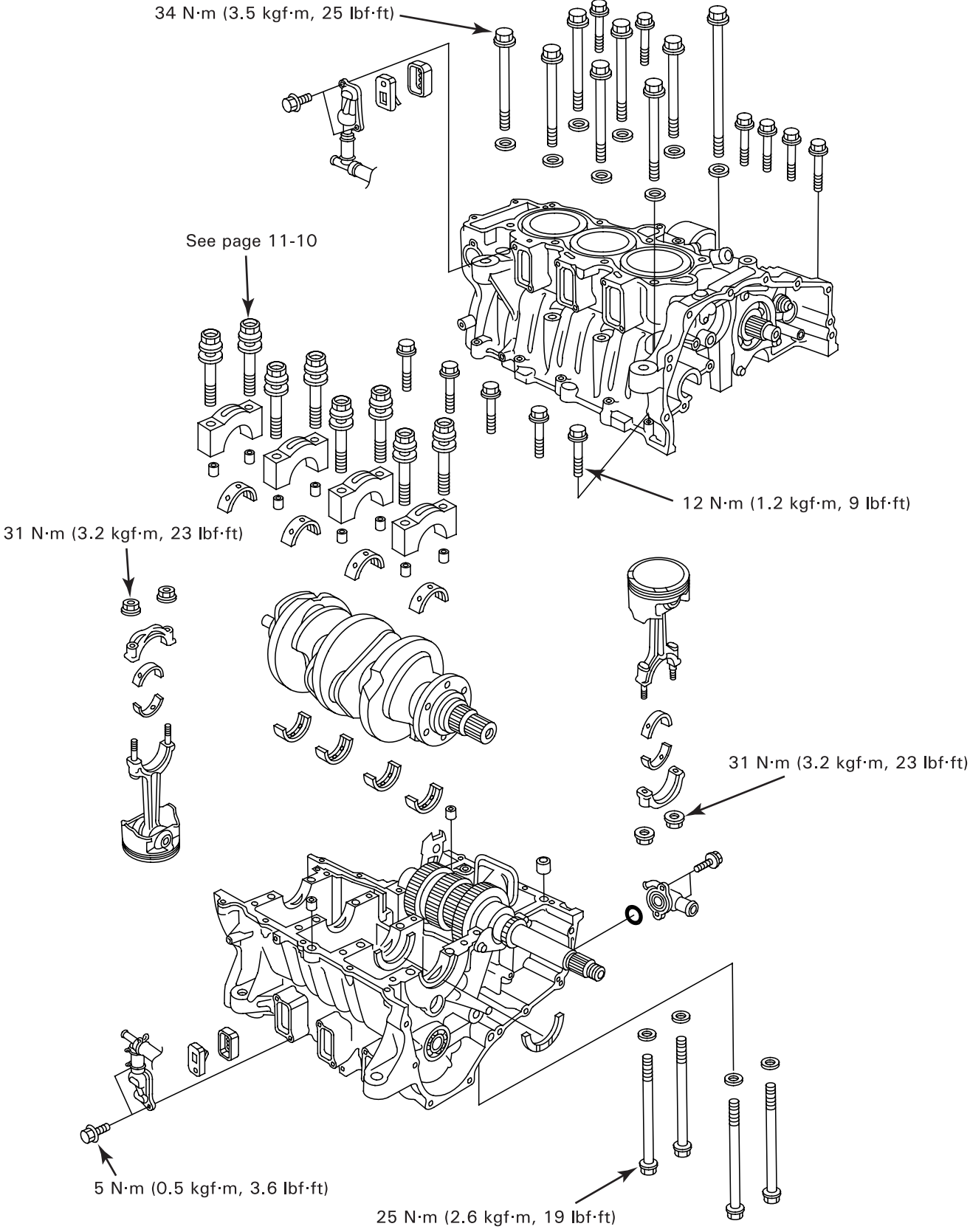

## SERVICE INFORMATION

### GENERAL

- The crankcase must be separated to service the piston/connecting rod, crankcase and crankshaft.
- Avoid damaging the pistons against the transmission gears or crankcase when separating the crankcase halves because the pistons will fall as the crankcase is pulled off them.
- Be careful not to damage the crankcase mating surface when servicing.
- Prior to assembling the crankcase halves, apply sealant to their mating surfaces. Wipe off excess sealant thoroughly.
- Mark and store the connecting rods, bearing caps, pistons, main journal bearing cap bolts and bearing inserts to be sure of their correct locations for reassembly.
- The crankpin and main journal bearing inserts are select fit and are identified by color codes. Select replacement bearings from the code tables. After selecting new bearings, recheck the oil clearance with plastigauge. Incorrect oil clearance can cause major engine damage.
- Before loosening the crankshaft bearing cap bolts, punch each bolt flange and main journal bearing cap at the same position to indicate the aligning point for tightening the bolts during reassembly.

### SPECIFICATIONS

Unit: mm (in)

ITEM		STANDARD	SERVICE LIMIT	
Cylinder	I.D.	74.000 – 74.015 (2.9134 – 2.9140)	74.10 (2.917)	
	Out-of-round	–	0.10 (0.004)	
	Taper	–	0.10 (0.004)	
	Warpage	–	0.05 (0.002)	
Piston, piston pin, piston ring	Piston O.D. at 10 mm (0.4 in) from bottom	73.970 – 73.990 (2.9122 – 2.9130)	73.85 (2.907)	
	Piston pin hole I.D.	18.010 – 18.016 (0.7091 – 0.7093)	18.03 (0.710)	
	Piston pin O.D.	17.994 – 18.000 (0.7084 – 0.7087)	17.99 (0.708)	
	Piston-to-piston pin clearance	0.010 – 0.022 (0.0004 – 0.0009)	0.05 (0.002)	
	Piston ring end gap	Top	0.15 – 0.30 (0.006 – 0.012)	0.5 (0.02)
		Second	0.30 – 0.45 (0.012 – 0.018)	0.6 (0.02)
		Oil (side rail)	0.20 – 0.70 (0.008 – 0.028)	0.9 (0.04)
	Piston ring-to-ring groove clearance	Top	0.025 – 0.055 (0.0010 – 0.0022)	0.10 (0.004)
Second		0.015 – 0.045 (0.0006 – 0.0018)	0.10 (0.004)	
Cylinder-to-piston clearance		0.010 – 0.045 (0.0004 – 0.0018)	0.10 (0.004)	
Crankshaft	Connecting rod side clearance		0.15 – 0.30 (0.006 – 0.012)	0.40 (0.016)
	Crankpin bearing oil clearance		0.028 – 0.046 (0.0011 – 0.0018)	0.06 (0.002)
	Main journal bearing oil clearance	1, 4	0.012 – 0.030 (0.0005 – 0.0012)	0.06 (0.002)
		2, 3	0.020 – 0.038 (0.0008 – 0.0015)	0.06 (0.002)
	Runout		–	0.03 (0.001)
	Crankpin and main journal	Taper	–	0.003 (0.0001)
Out-of-round		–	0.005 (0.0002)	

### TORQUE VALUES

Connecting rod bearing cap nut	31 N·m (3.2 kgf·m, 23 lbf·ft)	Apply engine oil to the threads and seating surface.
Crankshaft main journal bearing cap bolt	See page 11-15.	Apply engine oil to the threads and seating surface.
Left crankcase bolt	25 N·m (2.6 kgf·m, 19 lbf·ft)	
Right crankcase 10 mm bolt	34 N·m (3.5 kgf·m, 25 lbf·ft)	Apply engine oil to the threads and seating surface.
Right crankcase 6 mm bolt	12 N·m (1.2 kgf·m, 9 lbf·ft)	

**TOOLS**

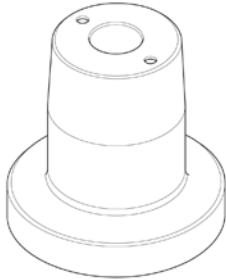
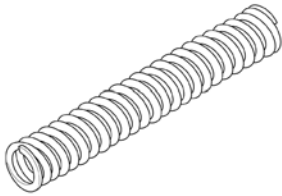
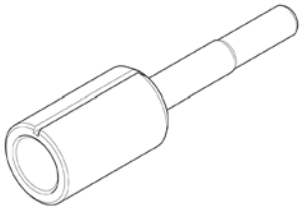
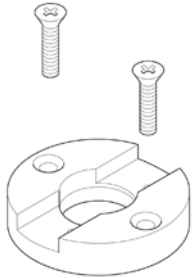
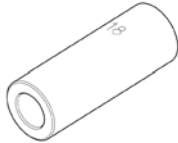
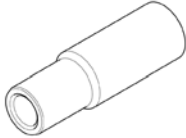
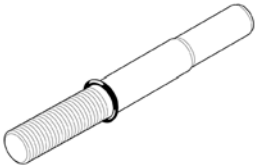
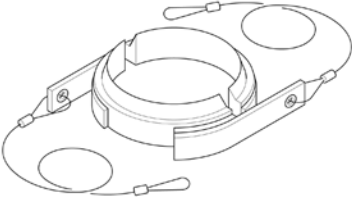
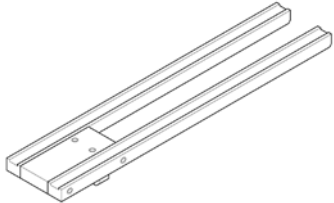
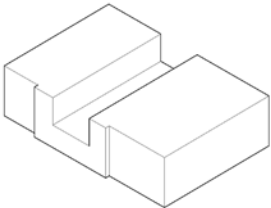
<p>Piston base 07973-6570500</p> 	<p>Piston base spring 07973-6570600</p> 	<p>Piston pin pilot 07PAF-0010300</p>  <p>or Pilot base insert 07973-6570400 (U.S.A. only)</p>
<p>Piston base head 07PAF-0010400</p>  <p>or 07JGF-001010A (U.S.A. only)</p>	<p>Pilot collar, 18 mm 07PAF-0010640</p>  <p>or 07KMF-MT20200 (U.S.A. only)</p>	<p>Adjustable piston pin driver head 07PAF-0010700</p>  <p>or 07973-6570210 (U.S.A. only)</p>
<p>Adjustable piston pin driver shaft 07PAF-0010800</p>  <p>or 07973-6570300</p>	<p>Piston ring compressor 07JMG-MN5000B (U.S.A. only)</p>  <p>or 07JMG-MN5000A (U.S.A. only)</p>	<p>Piston base A 07ZMG-MCAA100 (U.S.A. only)</p> 
<p>Piston base B 07ZMG-MCAA200 (U.S.A. only)</p> 		

## TROUBLESHOOTING

### **Compression too low, hard starting or poor performance at low speed**

- Leaking cylinder head gasket
- Worn, stuck or broken piston ring
- Worn or damaged cylinder and piston

### **Compression too high, overheating or knocking**

- Excessive carbon build-up on piston head or combustion chamber

### **Excessive smoke**

- Worn cylinder, piston or piston rings
- Improper installation of piston rings
- Scored or scratched piston or cylinder wall

### **Abnormal noise**

- Worn piston pin or piston pin hole
- Worn cylinder, piston or piston rings
- Worn main journal bearings
- Worn crankpin bearings

## CYLINDER/PISTON/CRANKSHAFT

### CRANKCASE SEPARATION

Remove the following:

- engine (section 7)
- PAIR check valves (section 5)
- cylinder head and cam chain (section 8)
- gearshift linkage (section 10)
- reverse shifter/shift drum lock arm (section 18)
- primary gears and output shaft (section 10: If you plan to service the transmission, remove the final drive gear)

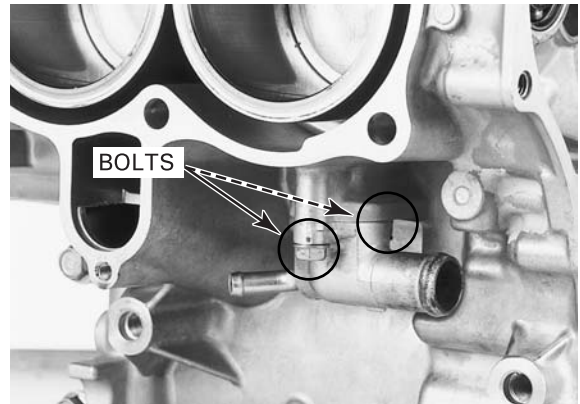

Remove the following from the left crankcase:

- two bolts
- water hose joint
- O-ring
- four 8-mm bolts and washers

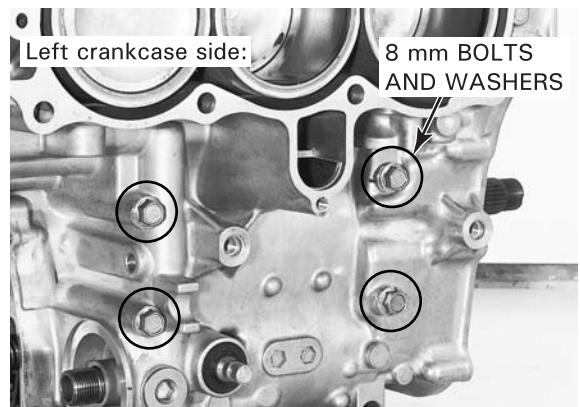

Place the engine with the left side down.

Loosen the eleven 6-mm bolts and eight 10-mm bolts in a crisscross cross pattern in several steps. Remove the bolts and washers.

Right crankcase side:

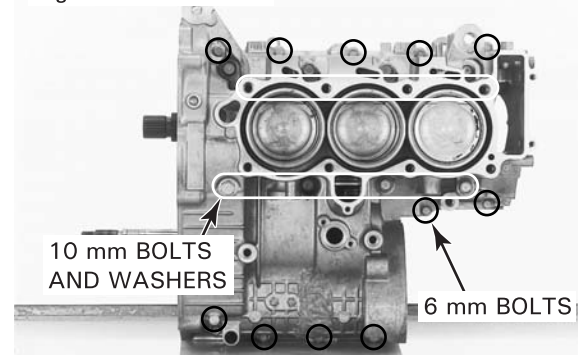

*Be careful not to damage the crankcase mating surfaces.*

Lift the right crankcase and separate the crankcase halves, and set suitable wooden blocks between them to support the right crankcase.

To prevent the pistons from falling and from being damaged when removing the right crankcase, place shop towels under the pistons and over the transmission gears and crankcase mating surfaces. Remove the right crankcase.

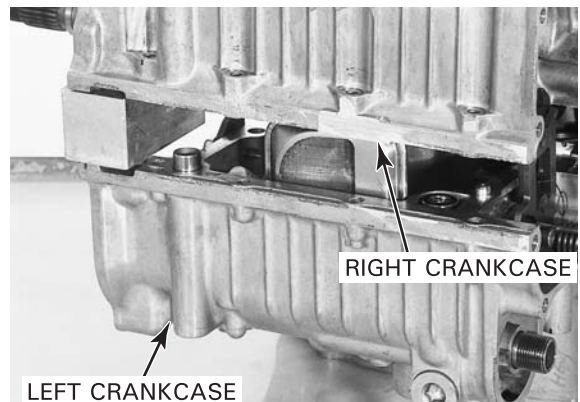



Remove the dowel pins and oil pipe.  
Clean any sealant from the crankcase mating surface.

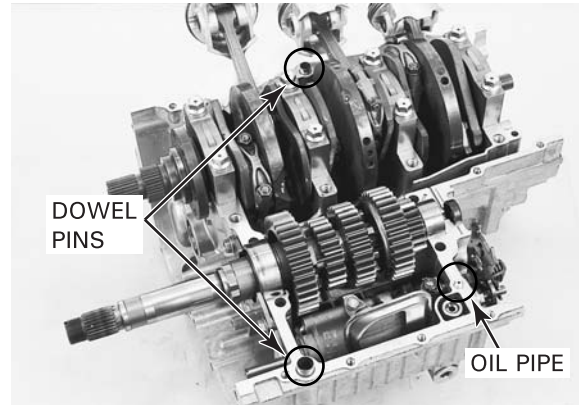

**PISTON/CONNECTING ROD REMOVAL**

Separate the crankcase halves (page 11-6).

**SIDE CLEARANCE INSPECTION**

Measure the connecting rod side clearance.

**SERVICE LIMIT: 0.40 mm (0.016 in)**

If the clearance exceeds the service limit, replace the connecting rod.

Recheck and if it is still out of specification, replace the crankshaft.



**PISTON/CONNECTING ROD REMOVAL**

NOTE:

- Mark the bearing caps, bearings, connecting rods and pistons as you remove them to indicate the correct cylinders.

*Tap the side of the cap lightly if the bearing cap is hard to remove. Be careful not to damage the crankpin and bearing inserts.*

Remove the bearing cap nuts, bearing caps and piston/connecting rod assemblies of the right cylinder (No. 1, 3 and 5).

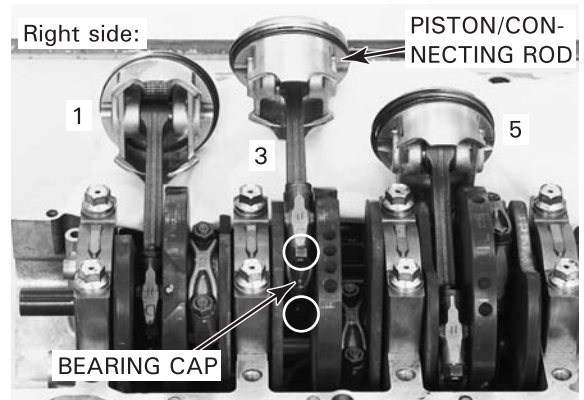

## CYLINDER/PISTON/CRANKSHAFT

Any ridge on the cylinder must be removed with an automotive type ridge reamer before removing the left side pistons.

Remove the bearing cap nuts and bearing caps on the left side connecting rods. Push the piston/connecting rod assemblies out through the top of the left cylinder bores (No. 2, 4 and 6).

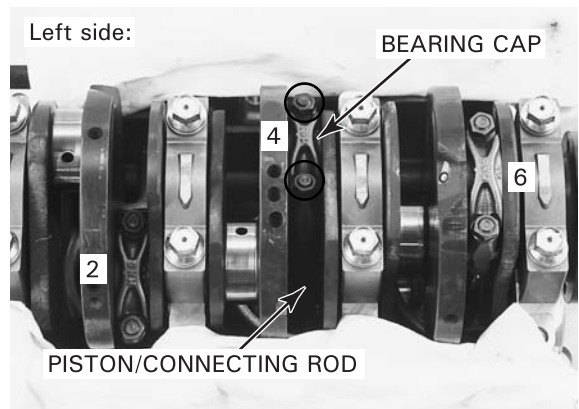
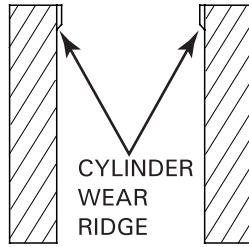

### PISTON/PISTON RING REMOVAL

Do not damage the piston ring by spreading the ends too far.

Spread each piston ring and remove it by lifting up at a point opposite the gap.

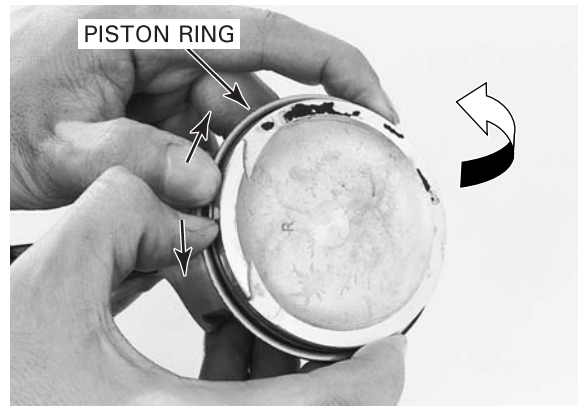

Never use a wire brush; it will scratch the groove.

Clean carbon deposits from the ring grooves with a used piston ring that will be discarded. Never use a wire brush; it will scratch the groove.



### PISTON INSPECTION

Inspect the piston rings for movement by rotating the rings. The rings should be able to move in their grooves without catching.

Push the ring until the outer surface of the piston ring is nearly flush with the piston and measure the ring-to-ring groove clearance.

**SERVICE LIMITS: Top/Second: 0.10 mm (0.004 in)**



Insert each piston ring into the bottom of the cylinder squarely using the piston crown. Measure the ring end gap.

**SERVICE LIMITS: Top: 0.5 mm (0.02 in)**  
**Second: 0.6 mm (0.02 in)**  
**Oil (side rail): 0.9 mm (0.04 in)**

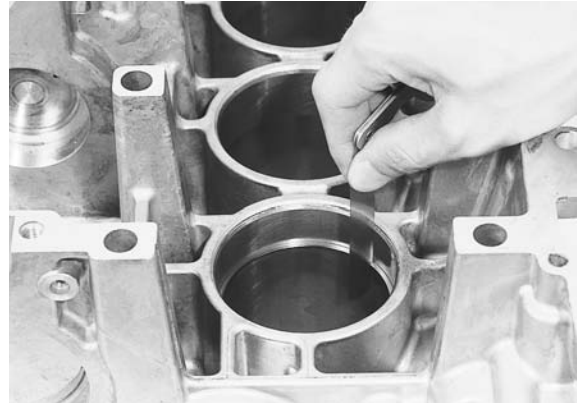

Measure the piston O.D. at a point 10 mm (0.4 in) from the bottom and 90° to the piston pin hole.

**SERVICE LIMIT: 73.85 mm (2.907 in)**

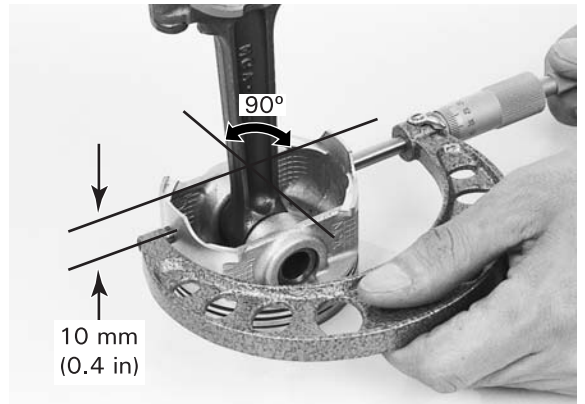

**CYLINDER INSPECTION**

Inspect the cylinder wall for scratches or wear. Measure the cylinder I.D. at three levels on the X and Y axes. Take the maximum reading to determine the cylinder wear.

**SERVICE LIMIT: 74.10 mm (2.917 in)**

Calculate the cylinder-to-piston clearance.

**SERVICE LIMIT: 0.10 mm (0.004 in)**

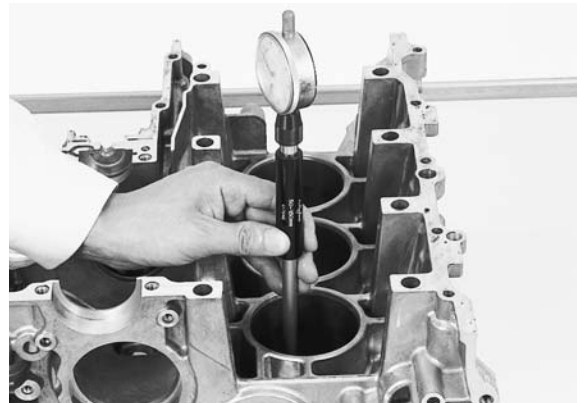

Calculate the cylinder taper and out-of-round at three levels on the X and Y axes. Take the maximum reading to determine the taper and out-of-round.

**SERVICE LIMITS: Taper: 0.10 mm (0.004 in)**  
**Out-of-round: 0.10 mm (0.004 in)**

The cylinder must be rebored and an oversize piston fitted if the service limits are exceeded.

The following oversize pistons are available:

- 0.25 mm (0.010 in)
- 0.50 mm (0.020 in)
- 0.75 mm (0.030 in)
- 1.00 mm (0.040 in)

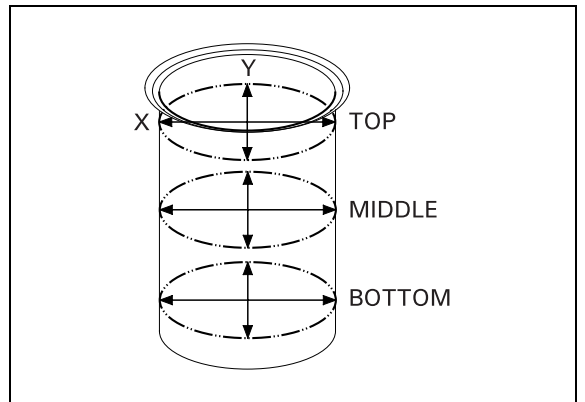

## CYLINDER/PISTON/CRANKSHAFT

The cylinder must be rebored so the clearance for an oversize piston is 0.010 – 0.045 mm (0.0004 – 0.0018 in).

Check the top of the cylinder for warpage with a straight edge and feeler gauge.

**SERVICE LIMIT: 0.05 mm (0.002 in)**

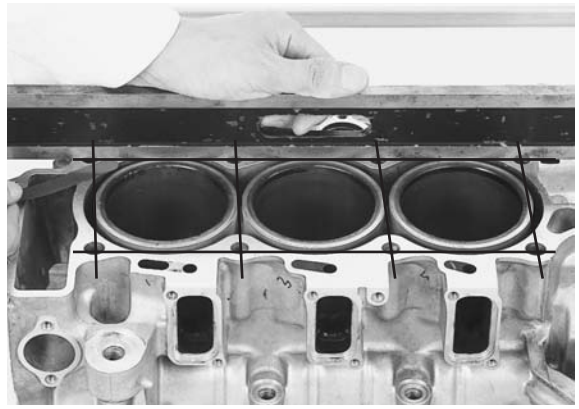

### PISTON REMOVAL

Assemble the special tools (piston base assembly) as shown.

#### TOOLS:

<b>Piston base</b>	<b>07973-6570500</b>
<b>Piston base spring</b>	<b>07973-6570600</b>
<b>Piston pin pilot</b>	<b>07PAF-0010300 or</b>
<b>Pilot base insert</b>	<b>07973-6570400</b>
	<b>(U.S.A. only)</b>
<b>Piston base head</b>	<b>07PAF-0010400 or</b>
	<b>07JGF-001010A</b>
	<b>(U.S.A. only)</b>

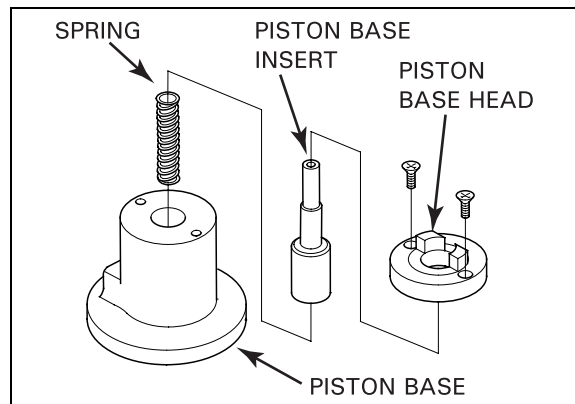

Set the piston by aligning its boss with the base head inserts and install the following special tools into the piston as shown.

Press the piston pin out of the connecting rod.

#### TOOLS:

<b>Pilot collar, 18 mm</b>	<b>07PAF-0010640 or</b>
	<b>07KMF-MT20200</b>
	<b>(U.S.A. only)</b>
<b>Adjustable piston pin driver head</b>	<b>07PAF-0010700 or</b>
	<b>07973-6570210</b>
	<b>(U.S.A. only)</b>
<b>Adjustable piston pin driver shaft</b>	<b>07PAF-0010800 or</b>
	<b>07973-6570300</b>
	<b>(U.S.A. only)</b>

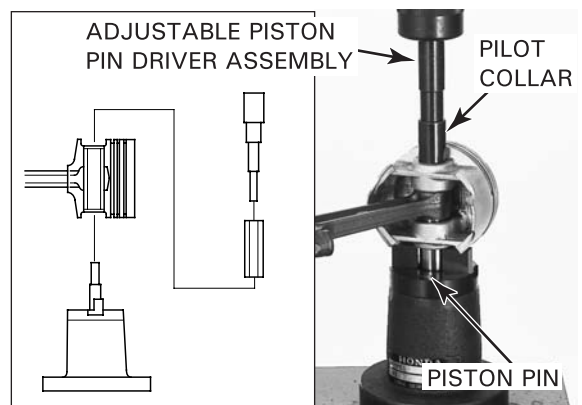

### PISTON/PISTON PIN INSPECTION

Measure the piston pin O.D. at piston pin hole areas.

**SERVICE LIMIT: 17.99 mm (0.708 in)**

Measure the piston pin hole I.D.

**SERVICE LIMIT: 18.03 mm (0.710 in)**

Calculate the piston-to-piston pin clearance.

**SERVICE LIMIT: 0.05 mm (0.002 in)**





**CONNECTING ROD SELECTION**

Letter A, B, C, D or E on the rod is the code for the connecting rod weight.

If a connecting rod requires replacement, you should select a rod with the same weight code as the original.

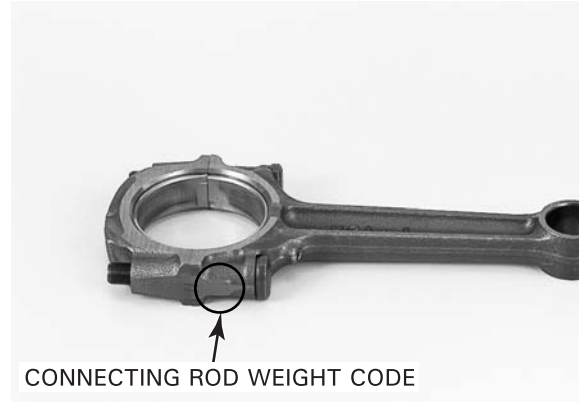

**CRANKPIN BEARING**

**BEARING INSPECTION**

Check the bearing inserts for unusual wear or peeling.

Check the bearing tabs for damage.

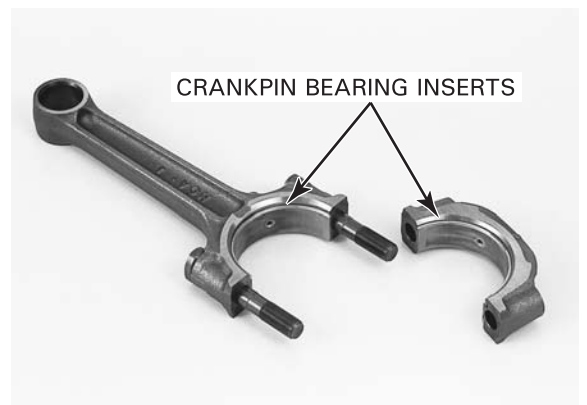

**OIL CLEARANCE INSPECTION**

*Do not rotate the crankshaft and connecting rod during inspection.*

Clean off any oil from the bearing inserts and crankpins.

Set the connecting rods onto the crankpins. Put strips of plastigauge lengthwise on the crankpins being sure to avoid the oil hole.

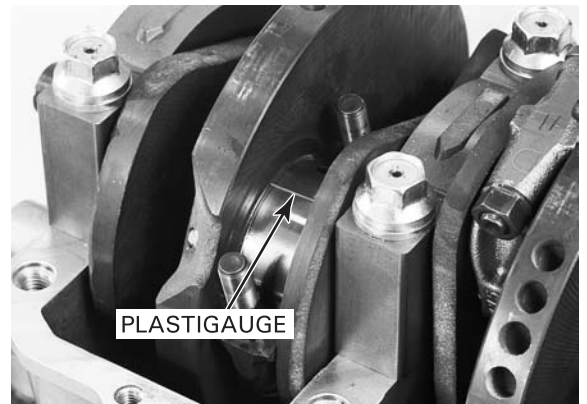

Carefully install the bearing caps by aligning the I.D. code.

Apply engine oil to the bearing cap nut threads and seating surfaces and install them.

Tighten the nuts in several steps alternately.

**TORQUE: 31 N·m (3.2 kgf·m, 23 lbf·ft)**

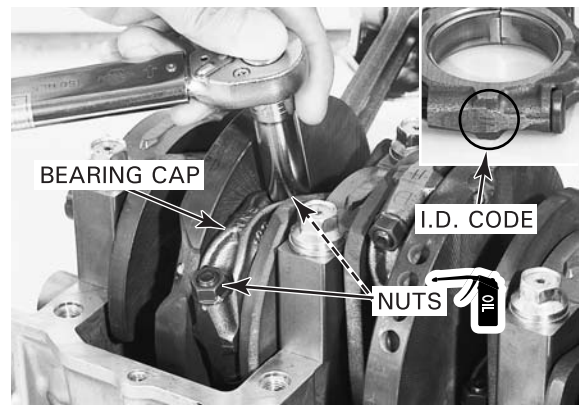

## CYLINDER/PISTON/CRANKSHAFT

Remove the bearing caps and measure the compressed plastigauge at its widest point on each crankpin to determine the oil clearance.

**SERVICE LIMIT: 0.06 mm (0.002 in)**

If the oil clearance exceeds the service limit, select the correct replacement bearings.

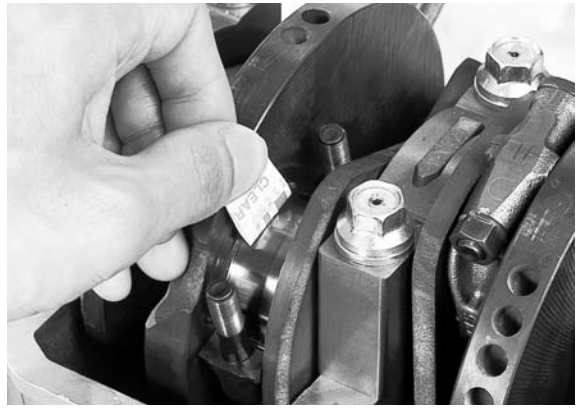

### BEARING SELECTION

Number 1 (I), 2 (II) or 3 (III) on the connecting rod is the code for the connecting rod I.D.

Record the connecting rod I.D. code numbers.

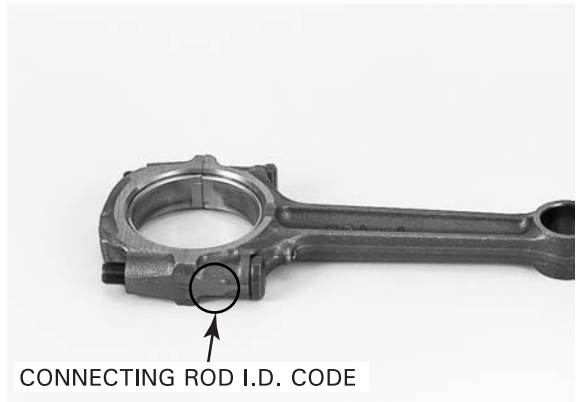

Letter A, B or C on the front side of the crankshaft are the codes for the crankpin O.D. in the sequence from the No. 1 crankpin (front to rear).

Record the crankpin O.D. code letters.

Cross reference the connecting rod and crankpin codes to determine the replacement bearing color code.

#### MAIN JOURNAL BEARING SELECTION TABLE:

		CONNECTING ROD I.D. CODE		
		1 (I)	2 (II)	3 (III)
CRANKPIN O.D. CODE	A	Yellow	Green	Brown
	B	Green	Brown	Black
	C	Brown	Black	Blue

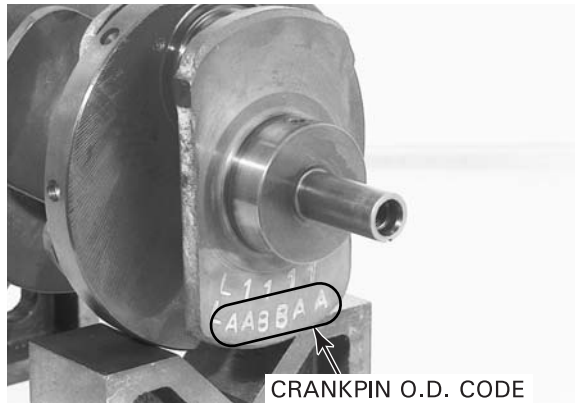

#### BEARING THICKNESS:

A (Blue)      Thick  
 B (Black):    ↑  
 C (Brown):   Middle  
 D (Green)    ↓  
 E (Yellow)    Thin

#### NOTICE

After selecting new bearings, recheck the oil clearance with plastigauge. Incorrect oil clearance can cause major engine damage.





**BEARING INSTALLATION**

Clean the bearing outer surfaces, bearing caps and connecting rods.  
 Install the crankpin bearing inserts onto the bearing caps and connecting rods, aligning each tab with each groove.

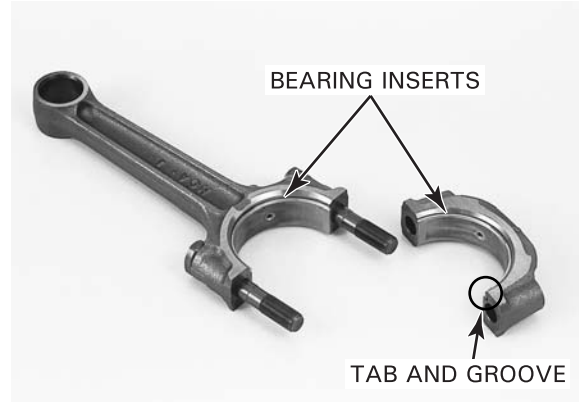

**CRANKSHAFT REMOVAL**

Remove the piston/connecting rod assemblies of the right cylinder and the bearing caps on the left cylinder connecting rod (page 11-7).

Before loosening the bearing cap bolts, punch each bolt flange and main journal bearing cap at the same position to indicate the aligning point for tightening the bolts during reassembly.

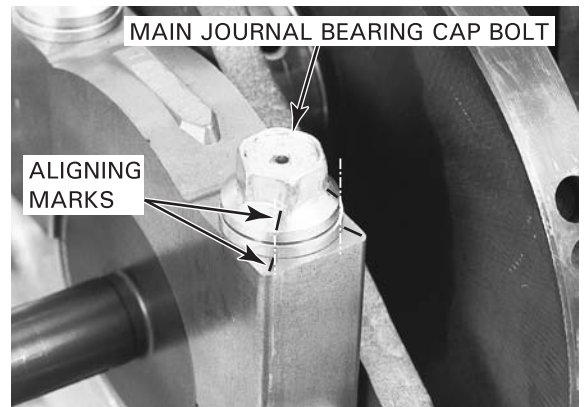

**NOTE:**

- Mark the bearing cap bolts and bearings as you remove them to indicate the correct journals.
- Remove the bolts and the main journal bearing caps.

*Do not forcibly remove the dowel pins from the bearing caps.*

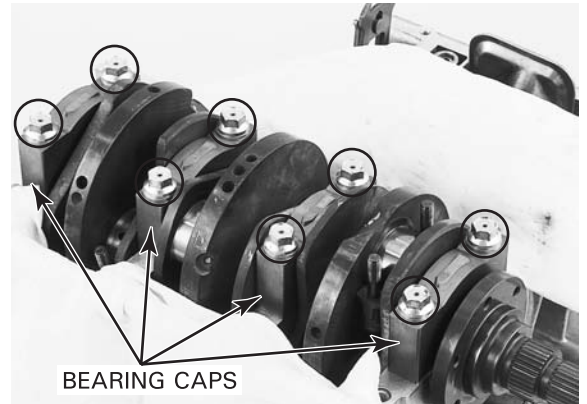

Move the left crankcase pistons to the top of the bores to avoid damaging the crankshaft with the connecting rod bolts.  
 Remove the crankshaft.

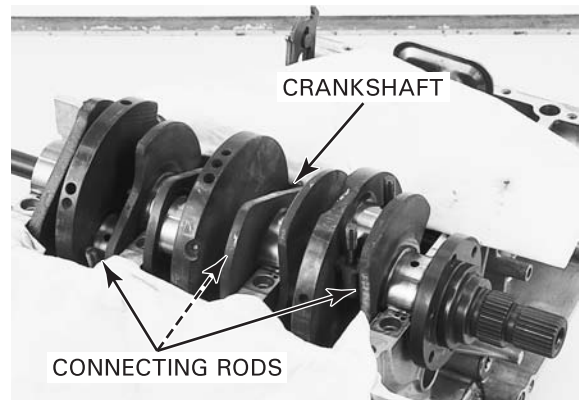

## CYLINDER/PISTON/CRANKSHAFT

### CRANKSHAFT INSPECTION

Hold both ends of the crankshaft and set a dial indicator on a main journal.  
Rotate the crankshaft two revolutions and read the runout at two points.  
Actual runout is 1/2 the total indicated reading.

**SERVICE LIMIT: 0.03 mm (0.001 in)**

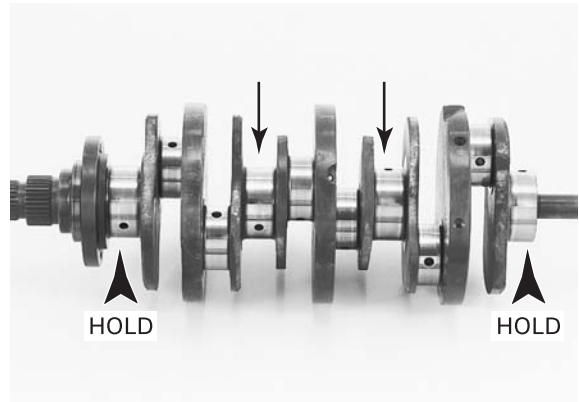

*The crankshaft cannot be repaired.*

Measure the main journals and crankpins with a micrometer for out-of-round and taper.

**SERVICE LIMITS: Taper: 0.003 mm (0.0001 in)  
Out-of-round: 0.005 (0.0002 in)**



## MAIN JOURNAL BEARING

### BEARING INSPECTION

Check the main journal bearing inserts on the left crankcase and main journal bearing caps for unusual wear or peeling.  
Check the bearing tabs for damage.

Check the thrust bearings on the rear end bearing support of the left crankcase for wear, scoring or discoloration and replace them if necessary.

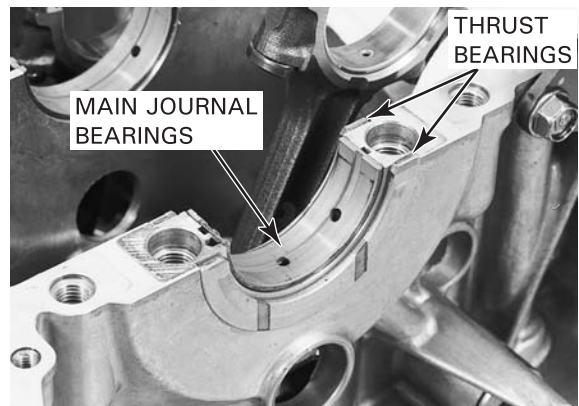

### OIL CLEARANCE INSPECTION

*Do not rotate the crankshaft during inspection.*

Clean off any oil from the bearing inserts and main journals.  
Carefully install the crankshaft onto the left crankcase.  
Put strips of plastigauge lengthwise on each main journal, being careful to avoid the oil passage.

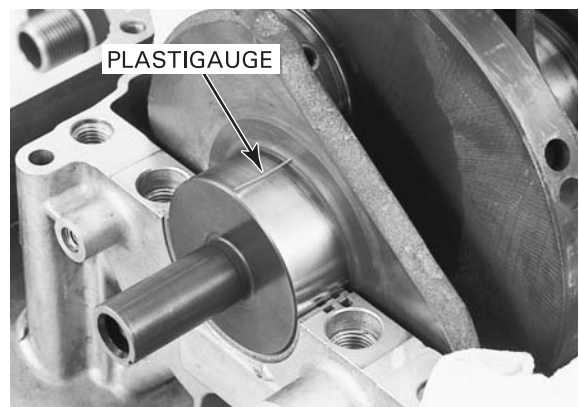

The installation position of each main journal bearing cap is identified with a dot mark that is aligned with the journal number 1, 2, 3 and 4, as viewed from the front of the engine.

Carefully install the dowel pins and main journal bearing caps onto the corresponding journals with the arrow facing toward the upper side of the engine.

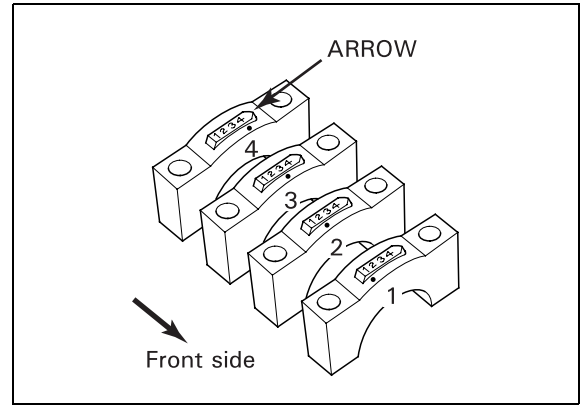

Apply engine oil to the bearing cap bolt threads and seating surfaces. Install the bolts into the correct bolt holes in the bearing caps.

Tighten the bolts in a crisscross pattern in several steps to the specified torque.

**TORQUE: 20 N·m (2.0 kgf·m, 14 lbf·ft) + 45°**

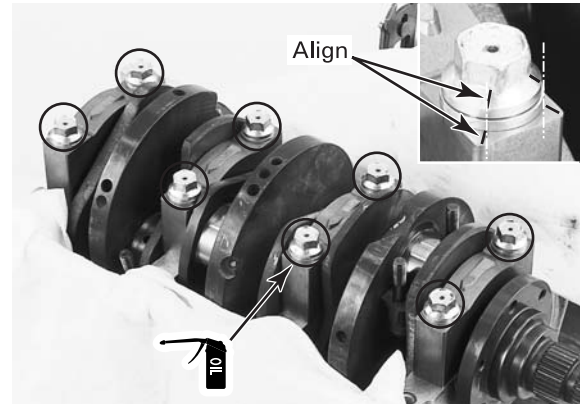

Remove the bearing caps and measure the compressed plastigauge at its widest point on each main journal to determine the oil clearance.

**SERVICE LIMIT: All journals: 0.06 mm (0.002 in)**

If the oil clearance exceeds the service limit, select the correct replacement bearings.



**BEARING SELECTION**

*Letter A, B or C on the front side of the left crankcase are the codes for the bearing support I.D. in the sequence from the No. 1 journal (front to rear).*

Record the crankcase bearing support I.D. code letters.

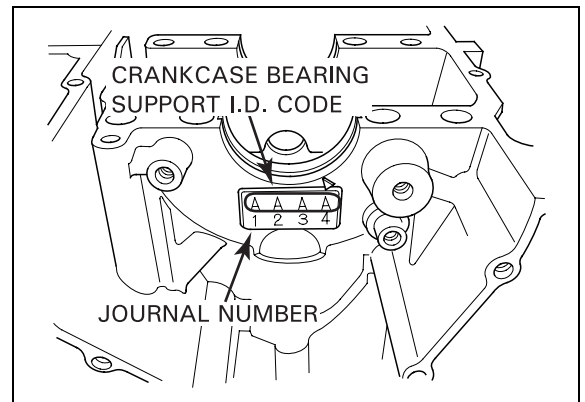

## CYLINDER/PISTON/CRANKSHAFT

Numbers 1, 2 or 3 on the front side of the crankshaft are the codes for the main journal O.D. in the sequence from the No. 1 journal (front to rear).

Record the main journal O.D. code numbers.

Cross reference the main journal and bearing support codes to determine the replacement bearing color code.

### CRANKPIN BEARING SELECTION TABLE:

		BEARING SUPPORT I.D. CODE		
		A	B	C
MAIN JOURNAL O.D. CODE	1	Yellow	Green	Brown
	2	Green	Brown	Black
	3	Brown	Black	Blue

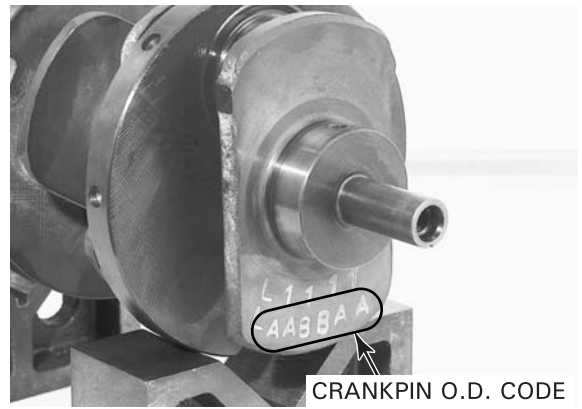

### BEARING THICKNESS:

A (Blue)      Thick  
 B (Black):    ↑  
 C (Brown):   Middle  
 D (Green)    ↓  
 E (Yellow)    Thin

### NOTICE

After selecting new bearings, recheck the oil clearance with plastigauge. Incorrect oil clearance can cause major engine damage.

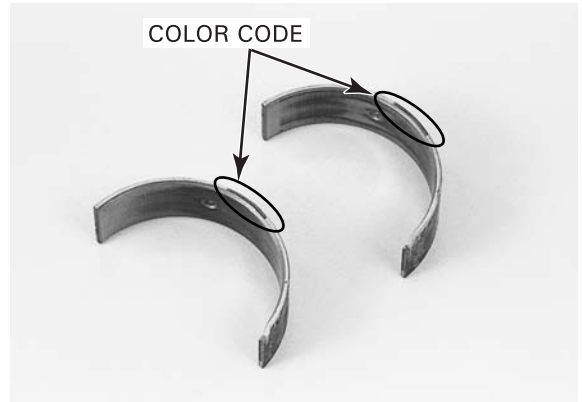

### BEARING INSTALLATION

Clean the bearing outer surfaces, bearing caps and crankcase bearing supports. Install the main journal bearing inserts onto the bearing caps and crankcase bearing supports, aligning each tab with each groove.

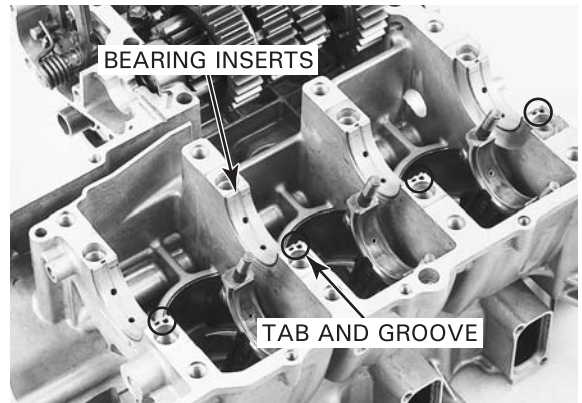

## CRANKSHAFT INSTALLATION

Install the thrust bearings onto the rear end bearing support of the left crankcase with the groove side facing the crankshaft.

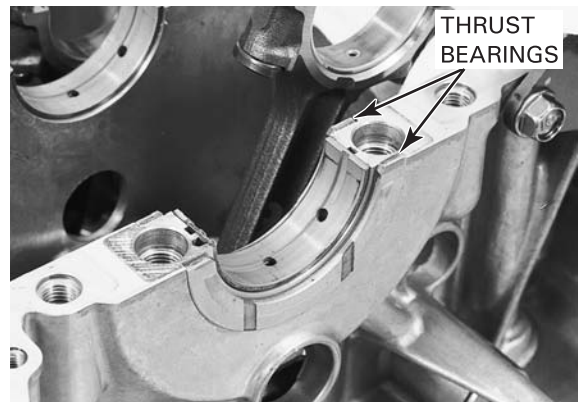



*Be careful not to damage the crankpins with the connecting rod bolts if the left cylinder pistons are installed in the crankcase.*

Apply molybdenum oil solution to the main journal bearing sliding surfaces on the left crankcase and main journal bearing caps. Carefully install the crankshaft onto the left crankcase.

Apply molybdenum oil solution to the crankpin bearing sliding surfaces on the connecting rods and set the connecting rods onto the crankpins if the left cylinder pistons are installed in the crankcase.

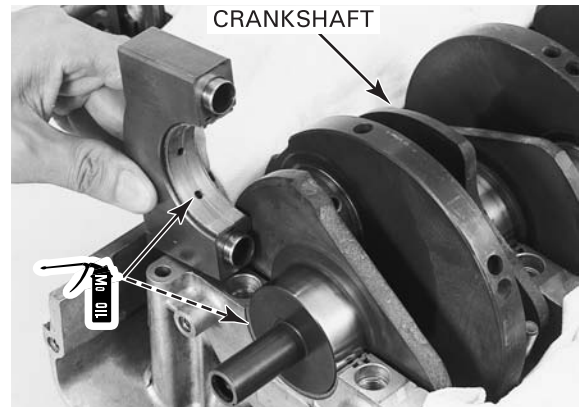

The installation position of each main journal bearing cap is identified with a dot mark that is aligned with the journal number 1, 2, 3 and 4, as viewed from the front of the engine. Install the dowel pins and main journal bearing caps onto the correct journals with the arrows facing toward the upper side of the engine.

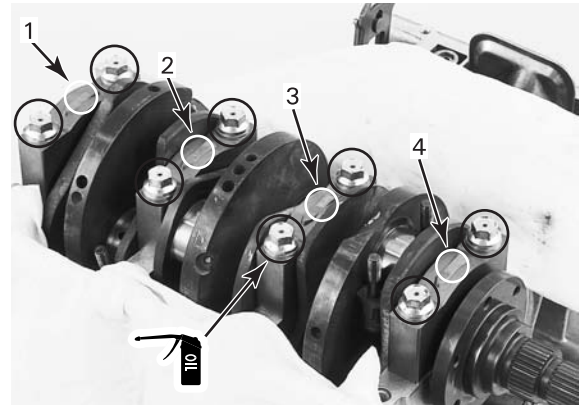

Apply engine oil onto the bearing cap bolt threads and seating surfaces. Install the bolts into the correct bolt holes in the bearing caps.

Tighten the bolts in a crisscross pattern in several steps to the specified torque.

**TORQUE: 20 N·m (2.0 kgf·m, 14 lbf·ft) + 45°**

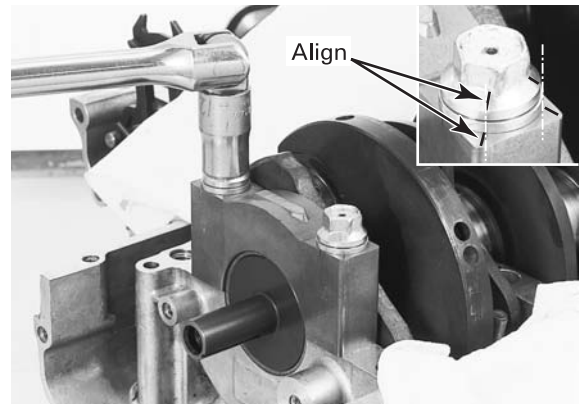

**PISTON/CONNECTING ROD INSTALLATION**

**PISTON INSTALLATION**

Turn the adjustable piston pin driver shaft in the adjustable piston pin driver head so that dimension A is 51 mm.

**TOOLS:**

- Adjustable piston pin driver head** 07PAF-0010700 or 07973-6570210 (U.S.A. only)
- Adjustable piston pin driver shaft** 07PAF-0010800 or 07973-6570300 (U.S.A. only)

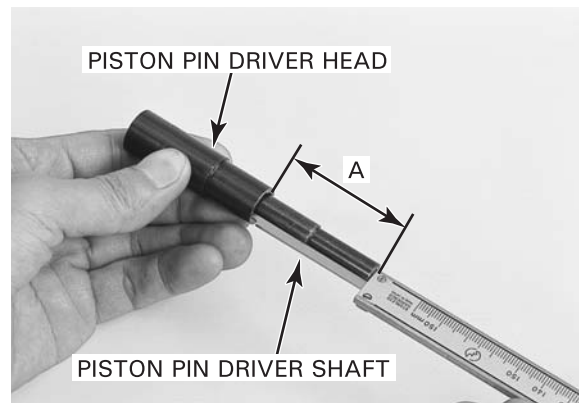

## CYLINDER/PISTON/CRANKSHAFT

Place a 12-mm flat washer on the top of the adjustable piston pin driver head. Have the crown of the piston facing the arrow on the piston base head.

Install the pilot collar into the piston base assembly. Set the piston and connecting rod over the pilot collar.

### TOOLS:

**Pilot collar, 18 mm**

**Piston base**

**Piston base spring**

**Piston pin pilot**

**Pilot base insert**

**Piston base head**

**07PAF-0010640 or 07KMF-MT20200 (U.S.A. only)**

**07973-6570500**

**07973-6570600**

**07PAF-0010300 or**

**07973-6570400 (U.S.A. only)**

**07PAF-0010400 or**

**07JGF-001010A (U.S.A. only)**

Right cylinder piston (No. 1, 3 and 5):

"R" mark on the piston head is facing the same direction as the oil hole in the connecting rod.

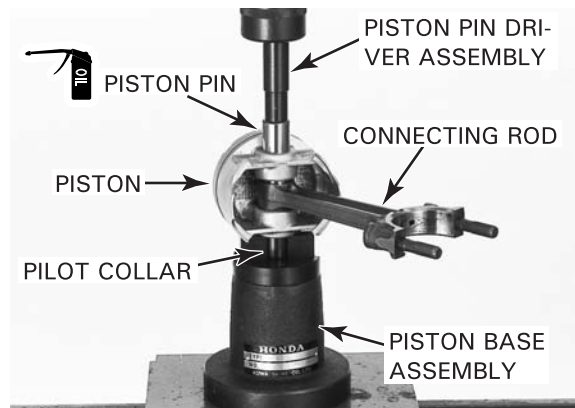

Right cylinder piston:

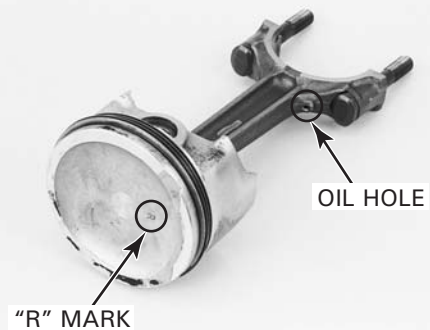

Left cylinder piston (No. 2, 4 and 6):

"L" mark on the piston head is opposite the oil hole in the connecting rod.

Left cylinder piston:

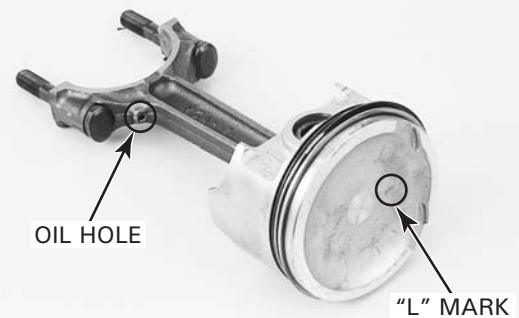

Apply engine oil to the piston pin outer surface.

Press the piston pin into the connecting rod through the piston until the hydraulic press stops (gauge rises slightly), using the adjustable piston pin driver assembly.

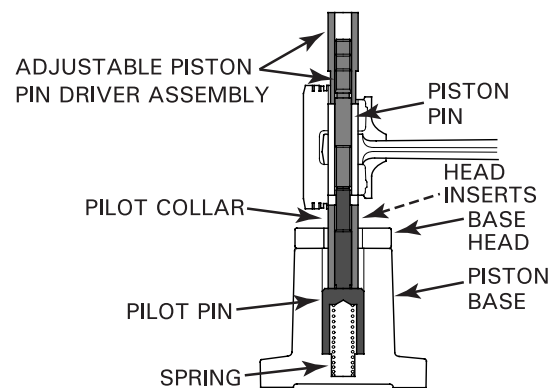



**PISTON RING INSTALLATION**

*Be careful not to damage the piston and rings.*

Carefully install the piston rings into the piston ring grooves with the markings facing up.

**NOTE:**

- Do not confuse the top and second rings.
- To install the oil ring, install the spacer first, then install the side rails.
- On the upper side rail of the left cylinder pistons (No. 2, 4 and 6), align the end stopper with the stopper groove.

Stagger the top and second piston ring end gaps 60 degrees apart "L" or "R" mark as shown. Stagger the side rail end gaps as shown.

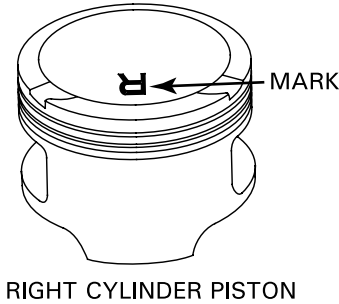
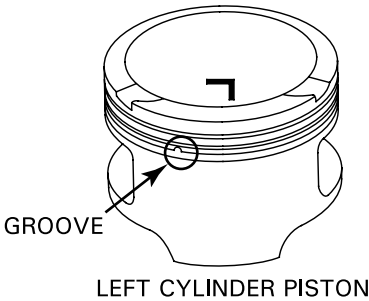
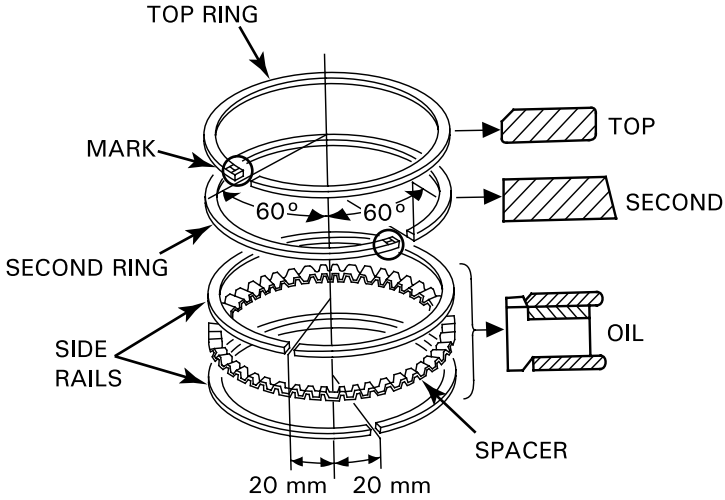
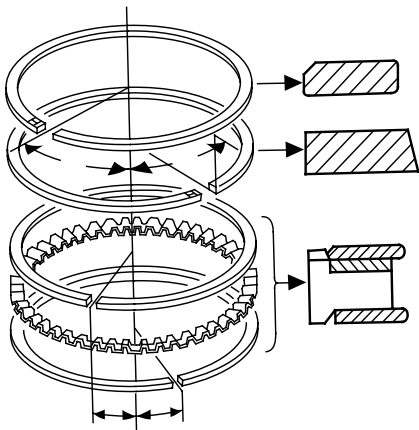
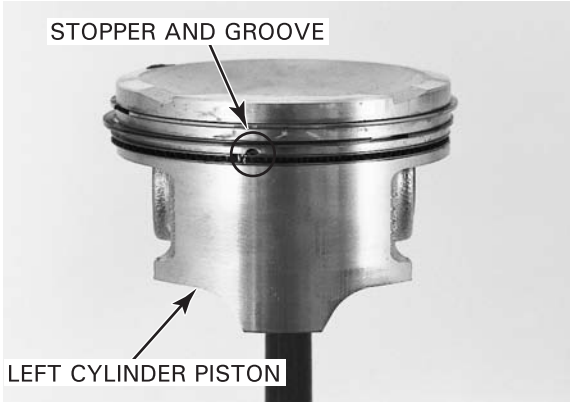

## CYLINDER/PISTON/CRANKSHAFT

### PISTON/CONNECTING ROD INSTALLATION

#### LEFT CYLINDER SIDE

Slip short sections of rubber hose over the connecting rod bolts to prevent damaging the crankpin.

Apply engine oil to the left cylinder wall, piston and piston rings.

*Be careful not to damage the piston rings and the cylinder wall by the connecting rod.*

Install the left piston/connecting rod assemblies (No. 2, 4 and 6) into the correct cylinders from the cylinder top of the left crankcase with the "L" mark toward the intake side, using a commercially available piston ring compressor tool.

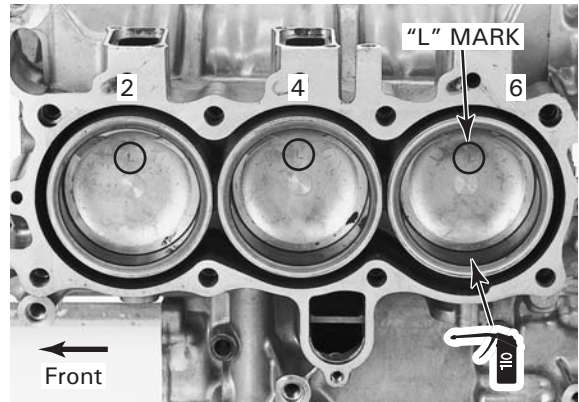

Apply molybdenum oil solution to the crankpin bearing sliding surfaces on the connecting rods. Set the connecting rods onto the crankpins.

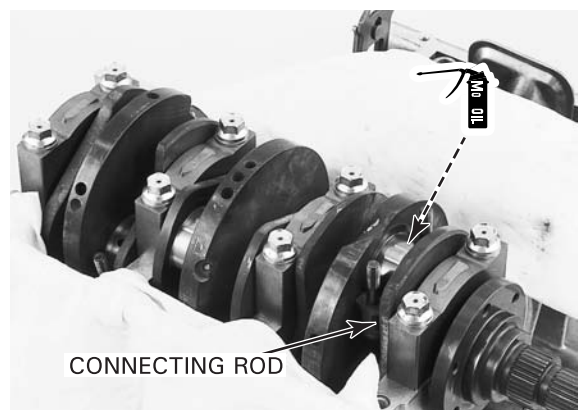

Apply molybdenum oil solution to the crankpin bearing sliding surfaces on the connecting rods. Install the bearing caps by aligning the I.D. code on the connecting rod and bearing cap. Be sure each part is installed in its correct position, as noted during removal.

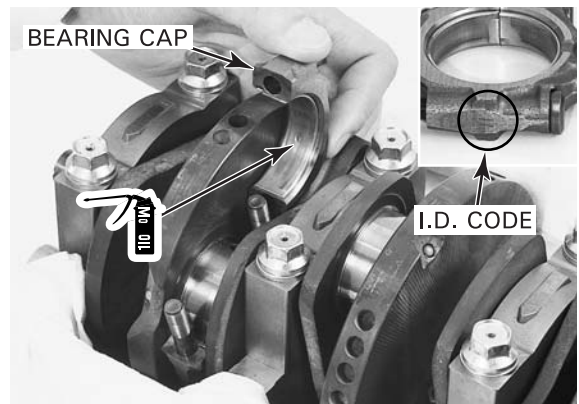

Apply engine oil to the bearing cap nut threads and seating surfaces and install the them. Tighten the nuts in several steps alternately.

**TORQUE: 31 N·m (3.2 kgf·m, 23 lbf·ft)**

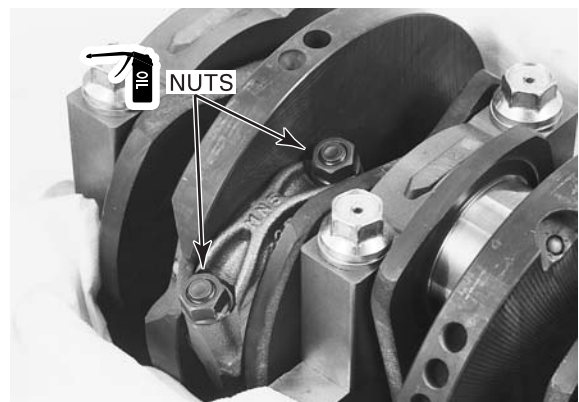

## RIGHT CYLINDER SIDE

Cover the transmission gears and crankcase mating surfaces with shop towels to prevent damaging the pistons during installation.

Apply molybdenum oil solution to the crankpin bearing sliding surfaces on the connecting rods and bearing caps.

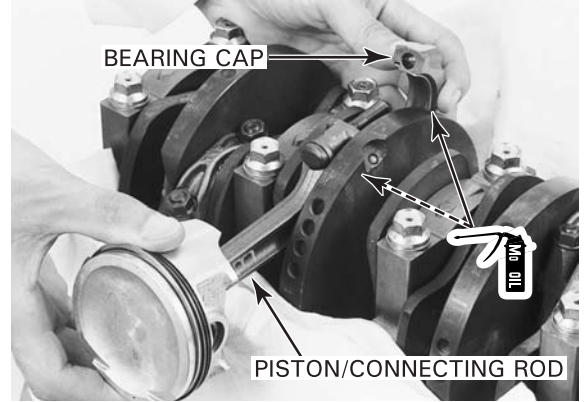

Install the right piston/connecting rod assemblies and bearing caps (No. 1, 3 and 5) onto the corresponding crankpins with the "R" mark toward the intake side by aligning the I.D. code. Be sure each part is installed in its correct position.

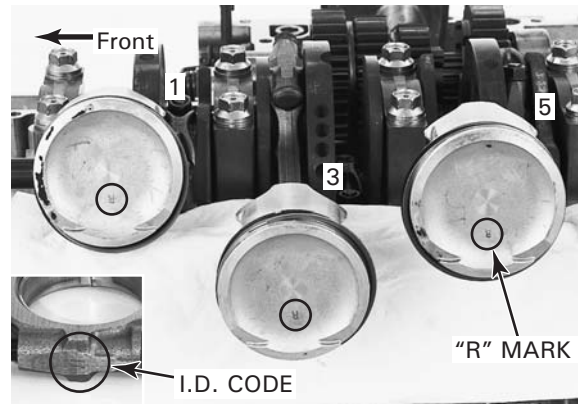

Apply engine oil to the bearing cap nut threads and seating surfaces and install the them.

Tighten the nuts in several steps alternately.

**TORQUE: 31 N-m (3.2 kgf-m, 23 lbf-ft)**

Assemble the crankcase halves.

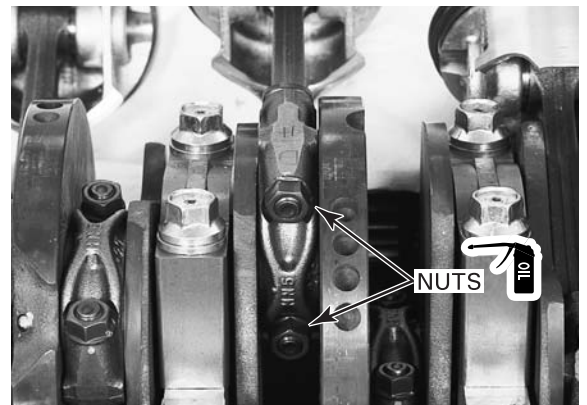

## CYLINDER/PISTON/CRANKSHAFT

# CRANKCASE ASSEMBLY

Clean the left and right crankcase mating surfaces.

Temporarily install the ignition pulse generator bolt.

*Be careful that the right cylinder pistons do not interfere with the transmission gears or crankcase.*

Turn the crankshaft and position the front piston (No. 1) to the top dead center (highest position) while holding the right cylinder pistons.

Apply engine oil to the cylinder wall, piston and piston rings.

Install the special tools as shown.

### TOOLS:

**Piston ring compressor**

**07JMG-MN5000B or  
07JMG-MN5000A  
(3 pcs) (U.S.A. only)**

**Piston base A**

**07ZMG-MCAA100  
(U.S.A. only)**

**Piston base B**

**07ZMG-MCAA200  
(U.S.A. only)**

Prepare wooden blocks (40 x 40 x 85 mm) for support of crankcase.

Cover the transmission gears and crankcase mating surfaces with shop towel to prevent damaging them.

Place the support blocks lengthwise onto the left crankcase mating surfaces.

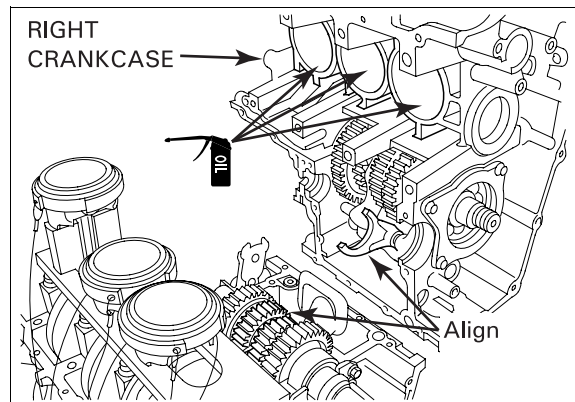
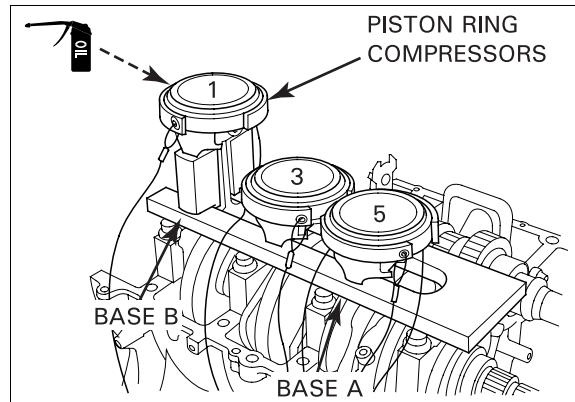

Hold the right crankcase over the left crankcase and set the front cylinder (No. 1) straight onto the No. 1 piston while aligning the center shift fork with the transmission gear shifter groove. The right crankcase will rest on the support blocks.

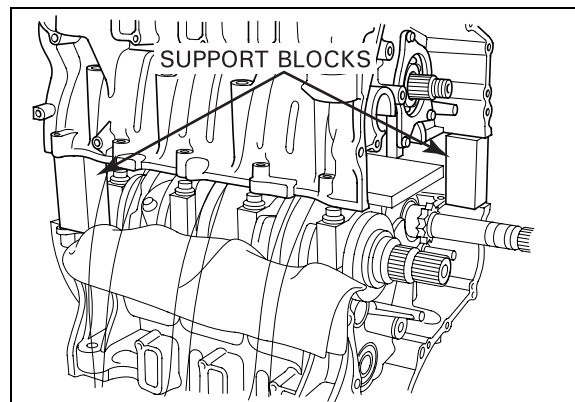

Carefully pull the wires of the No. 1 piston ring compressor to separate the two halves and remove the No. 1 compressor out of the crankcase.

Remove piston base B.

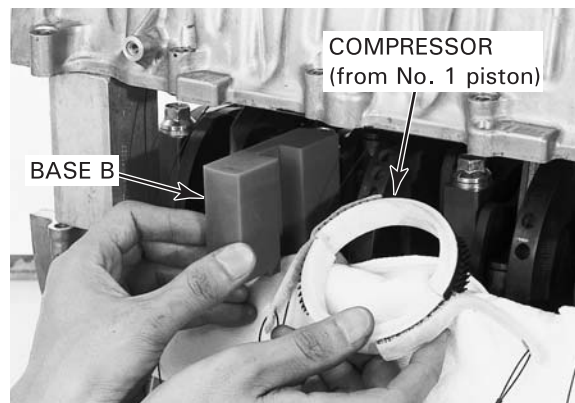

## CYLINDER/PISTON/CRANKSHAFT

Have an assistant turn the support blocks on their sides.  
Set both cylinders (No. 3 and 5) of the right crankcase straight onto the pistons and let the crankcase rest onto the support blocks.

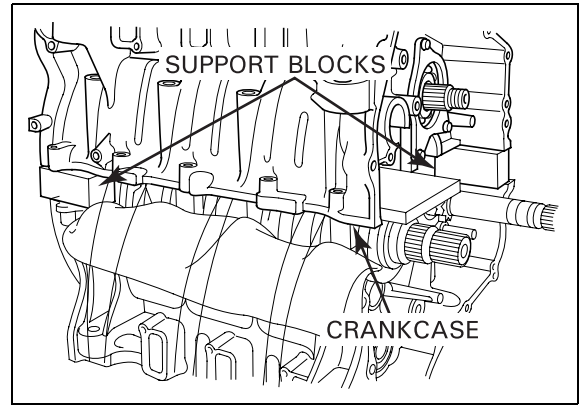

Remove piston base A.  
Pull the cords of the piston ring compressors to separate the two halves and remove the remaining compressors.

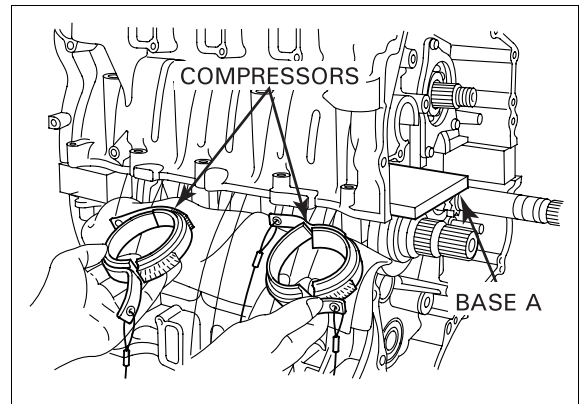

Remove the shop towels.  
Install the two dowel pins and oil pipe.

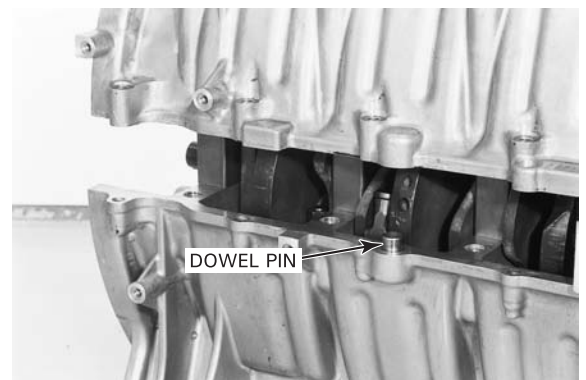
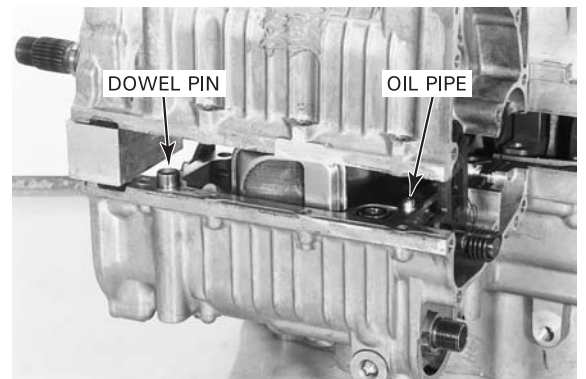



## CYLINDER/PISTON/CRANKSHAFT

Apply sealant to the crankcase mating surface as shown.

Have an assistant hold the right crankcase while you remove the support blocks and apply sealant to the areas where the support blocks were.

Lower the right crankcase and place it onto the left crankcase.

Make sure there are no gaps between the crankcase mating surfaces after assembling the crankcase halves.

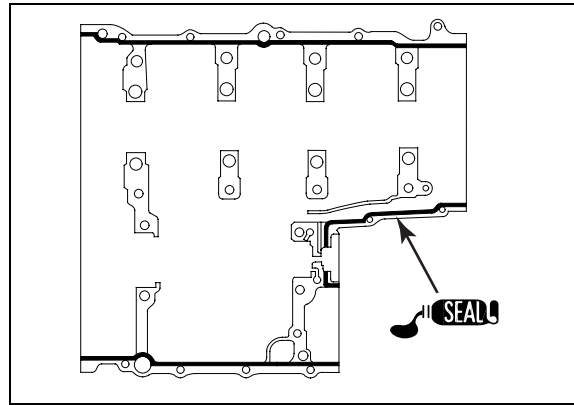

Apply engine oil to the threads and seating surface of the right crankcase 10-mm bolts.

Install the eight 10-mm bolts, new washers and eleven 6-mm bolts into the right crankcase.

Tighten bolts in a crisscross cross pattern in several steps.

### TORQUE:

**10 mm bolt: 34 N·m (3.5 kgf·m, 25 lbf·ft)**

**6 mm bolt: 12 N·m (1.2 kgf·m, 9 lbf·ft)**

Right crankcase side:

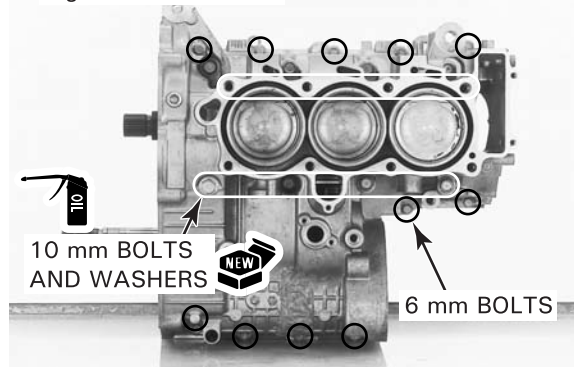

Install the four 8-mm bolts and new washers into the left crankcase and tighten them in a crisscross pattern in several steps.

**TORQUE: 25 N·m (2.6 kgf·m, 19 lbf·ft)**

Left crankcase side:

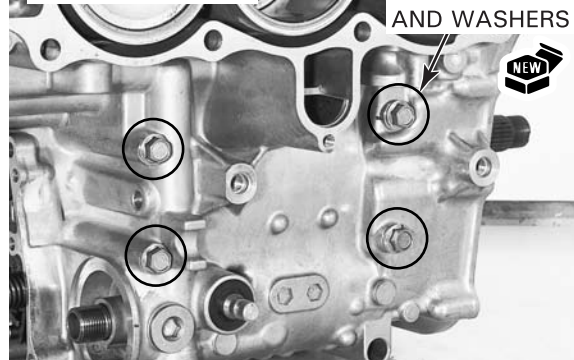

Install a new O-ring into the water hose joint. Install the water hose joint with the large spout facing the rear of the engine and tighten the two bolts.

Install the following:

- primary gears and output shaft (section 10)
- reverse shifter/shift drum lock arm (section 18)
- gearshift linkage (section 10)
- PAIR check valves (section 5)
- cylinder head and cam chain (section 8)

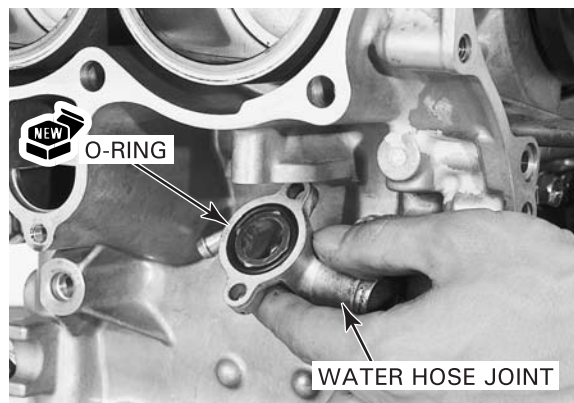



# 12. FINAL DRIVE

---

COMPONENT LOCATION .....	12-2	FINAL DRIVE DISASSEMBLY/ INSPECTION .....	12-9
SERVICE INFORMATION .....	12-3	CASE BEARING REPLACEMENT.....	12-14
TROUBLESHOOTING .....	12-6	FINAL DRIVE ASSEMBLY .....	12-17
FINAL DRIVE REMOVAL .....	12-7	FINAL DRIVE INSTALLATION .....	12-22

# FINAL DRIVE

## COMPONENT LOCATION

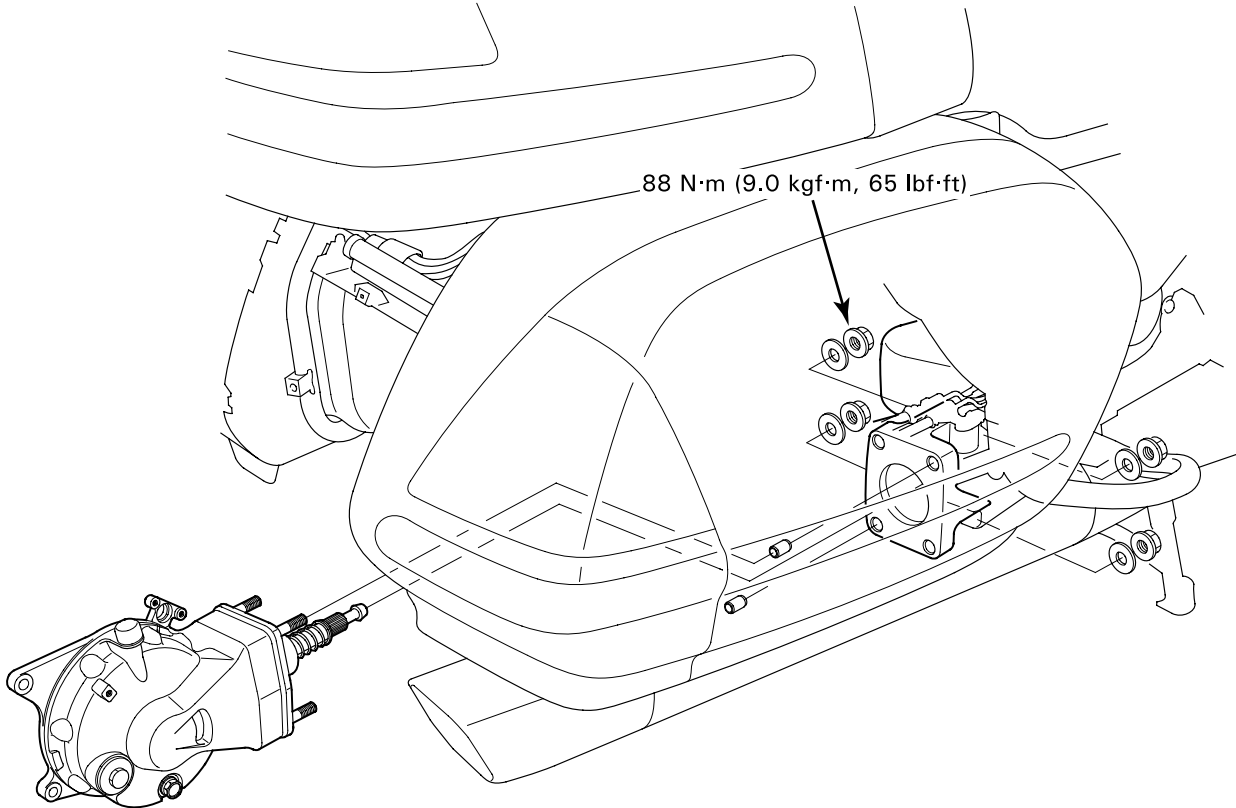
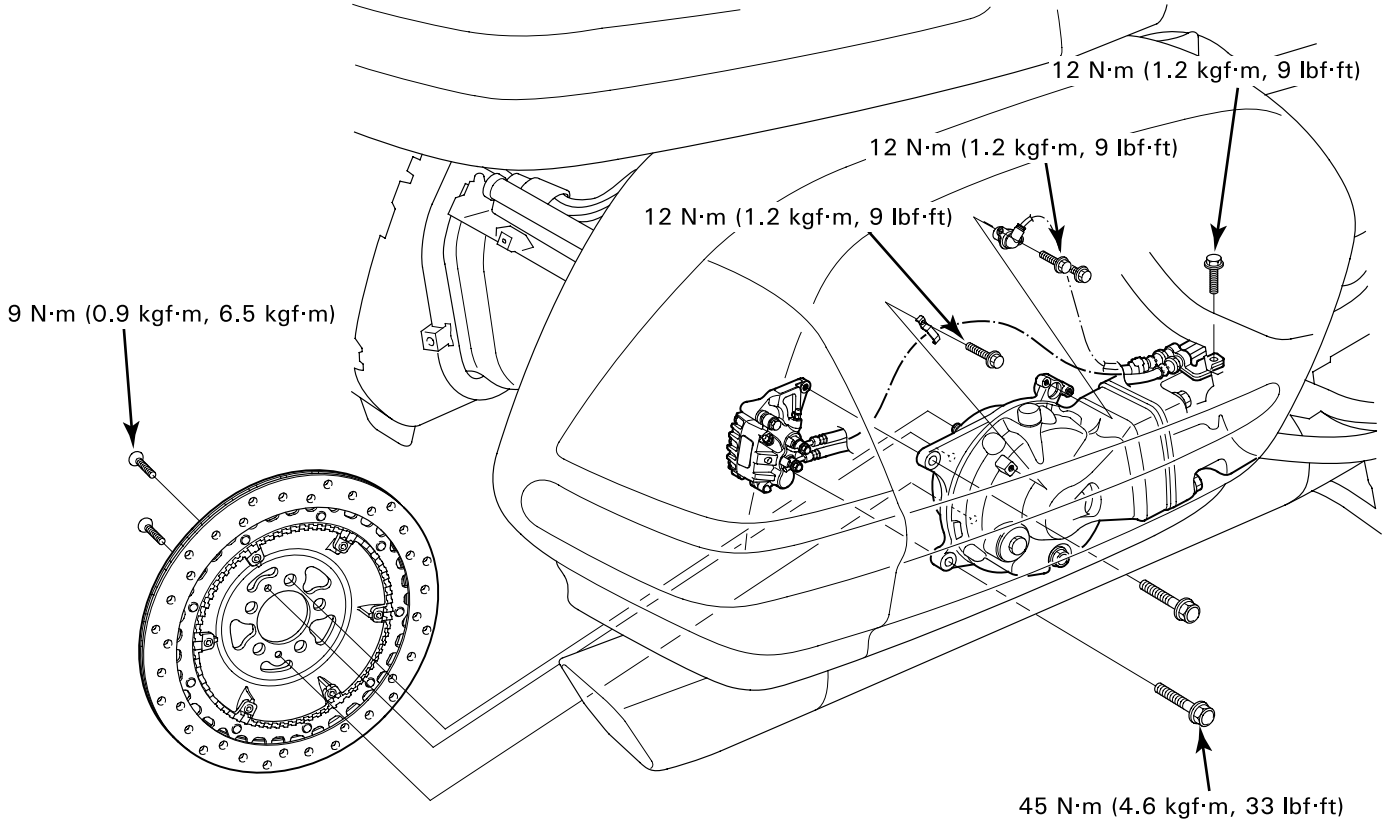

## SERVICE INFORMATION

### GENERAL

- Perform the gear contact pattern and backlash inspection whenever you replace the bearings, gears or gear case. The extension lines from the gear engagement surfaces should intersect at one point.
- Protect the gear case with a shop towel or soft jaws while holding it in a vise. Do not clamp the gear case too tight or it could get damaged.
- Replace the ring and pinion gears as a set.

### SPECIFICATIONS

Unit: mm (in)





ITEM		STANDARD	SERVICE LIMIT
Recommended final drive oil		Hypoid gear oil, SAE #80	-
Final drive oil capacity	After draining	120 cm <sup>3</sup> (4.1 US oz, 4.2 Imp oz)	-
	After disassembly	150 cm <sup>3</sup> (5.1 US oz, 5.3 Imp oz)	-
Final drive gear backlash		0.05 – 0.15 (0.002 – 0.006)	0.30 (0.012)
Backlash difference between measurements		-	0.10 (0.004)
Final drive gear assembly preload		0.2 – 1 N·m (2 – 10 kgf·cm, 1.7 – 8.7 lbf·in)	-



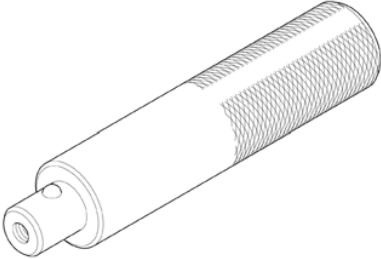

### TORQUE VALUES

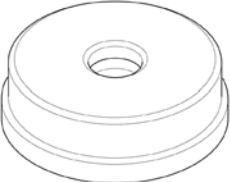
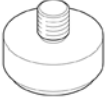
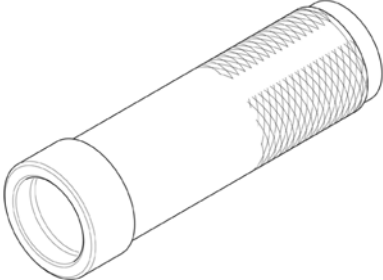
Pinion retainer	147 N·m (15.0 kgf·m, 108 lbf·ft)	Apply engine oil to the threads and seating surface.
Pinion retainer lock tab bolt	10 N·m (1.0 kgf·m, 7 lbf·ft)	
Pinion joint nut	108 N·m (11.0 kgf·m, 80 lbf·ft)	Apply locking agent to the threads.
Final side flange screw	9 N·m (0.9 kgf·m, 6.5 lbf·ft)	ALOC screw: replace with a new one.
Gear case cover 10 mm bolt	62 N·m (6.3 kgf·m, 46 lbf·ft)	Apply locking agent to the threads.
Gear case cover 8 mm bolt	25 N·m (2.6 kgf·m, 19 lbf·ft)	Apply locking agent to the threads.
Final gear case assembly mounting nut	88 N·m (9.0 kgf·m, 65 lbf·ft)	
Rear brake disc screw	9 N·m (0.9 kgf·m, 6.5 lbf·ft)	ALOC screw: replace with a new one.
Rear brake caliper mounting bolt	45 N·m (4.6 kgf·m, 33 lbf·ft)	ALOC bolt: replace with a new one.
Brake hose clamp bolt	12 N·m (1.2 kgf·m, 9 lbf·ft)	
Rear brake hose guide bolt (After '03)	12 N·m (1.2 kgf·m, 9 lbf·ft)	
Wheel speed sensor bolt (ABS model)	12 N·m (1.2 kgf·m, 9 lbf·ft)	

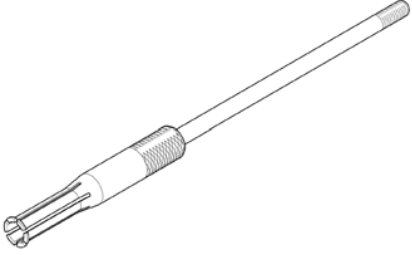
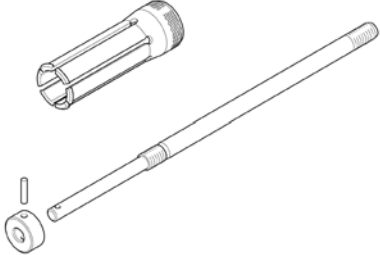
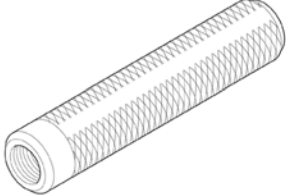
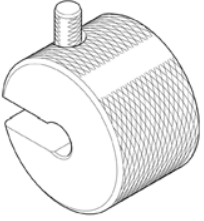
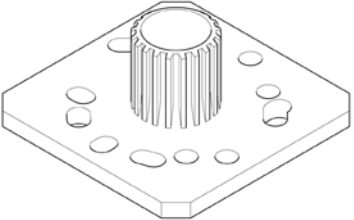
# FINAL DRIVE

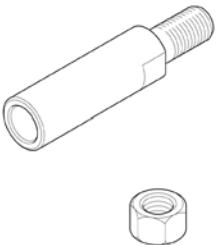
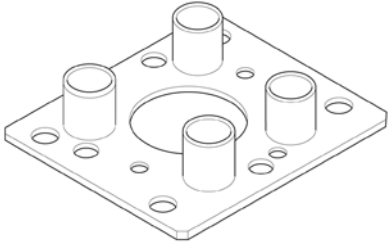
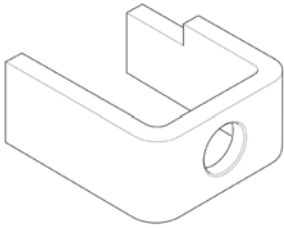
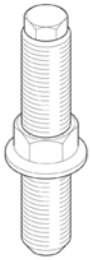
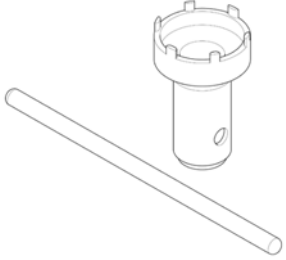
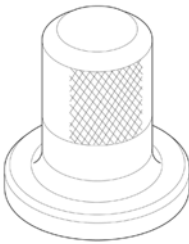
## TOOLS

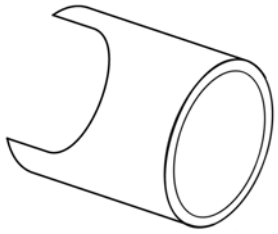
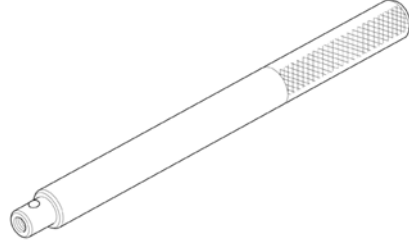
<p>Driver 07749-0010000</p> 	<p>Attachment, 42 x 47 mm 07746-0010300</p> 	<p>Attachment, 52 x 55 mm 07746-0010400</p> 
<p>Attachment, 62 x 68 mm 07746-0010500</p> 	<p>Pilot, 30 mm 07746-0040700</p> 	<p>Driver, 40 mm I.D. 07746-0030100</p> 
<p>Attachment, 25 mm I.D. 07746-0030200</p> 	<p>Bearing remover, 20 mm 07936-3710600</p> 	<p>Bearing remover, 30 mm 07936-8890300</p>  <p>or 07736-A01000B or 07736-A01000A (U.S.A. only) with slide hammer, 3/8" x 16 mm thread</p>
<p>Remover handle 07936-3710100</p> 	<p>Bearing remover weight 07741-0010201</p>  <p>or 07936-371020A or 07936-371020 (U.S.A. only) or equivalent commercially available in U.S.A.</p>	<p>Pinion holder 07924-ME40010</p> 

<p>Collar set "C" 07924-ME40020</p> 	<p>Holder plate 07924-9690103</p>  <p>or 07924-9690101 (modified)</p>	<p>Pinion puller base 07HMC-MM80110</p>  <p>or 07HMC-MM8011A (U.S.A. only)</p>
<p>Puller shaft 07931-ME40000</p>  <p>or 07931-ME4010B and 07931-HB3020A (U.S.A. only)</p>	<p>Retainer wrench 07910-4630100</p> 	<p>Oil seal driver 07948-SC20200</p>  <p>or 07749-0010000, 07946-ME90200 and 07947-KA50100</p>
<p>Assembly base 07ZMF-MCAA300</p> 	<p>Bearing clip compressor, 35 mm 07ZME-MCAA100</p> 	<p>Driver 07949-3710001</p> 
<p>Attachment, 32 x 35 mm 07746-0010100</p> 	<p>Pilot, 20 mm 07746-0040500</p> 	

## TROUBLESHOOTING

### **Excessive noise**

- Worn or scored pinion and splines
- Worn pinion and ring gears
- Excessive backlash between pinion and ring gears
- Oil level too low

### **Oil leakage**

- Clogged breather
- Oil level too high
- Damaged seals
- Loose case cover bolts



## FINAL DRIVE REMOVAL

Drain the final drive gear case oil (page 3-15).

Remove the following:

- right muffler (page 2-18)
- rear wheel (page 14-14)

Remove the following from the final drive assembly:

- '01 - '03: two bolts and wheel speed sensor

'01 - '03:

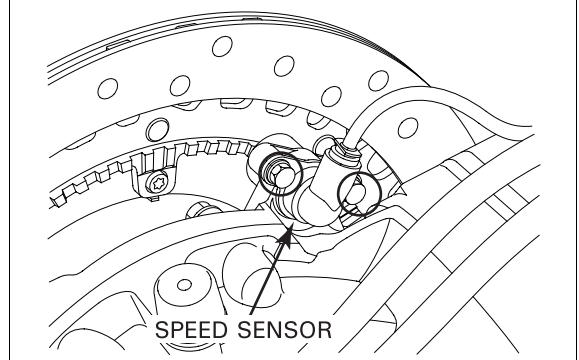

- After '03: two bolts, brake hose guide and wheel speed sensor

After '03:

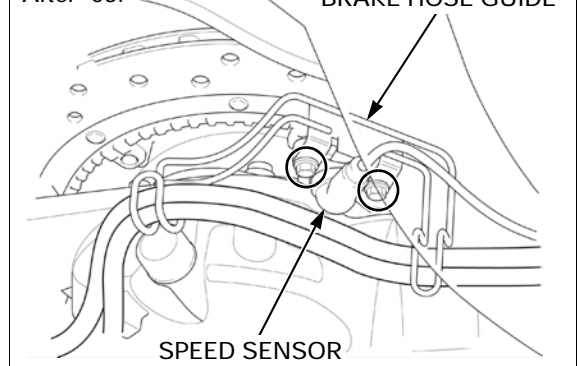

- '01 - '03 only: bolt and brake hose clamp
  - bolt and brake pipe clamp (from swingarm)
  - two bolts and brake caliper
- Support the brake caliper so it does not hang from the brake hose. Do not twist the brake hose. Do not operate the brake pedal after removing the caliper.

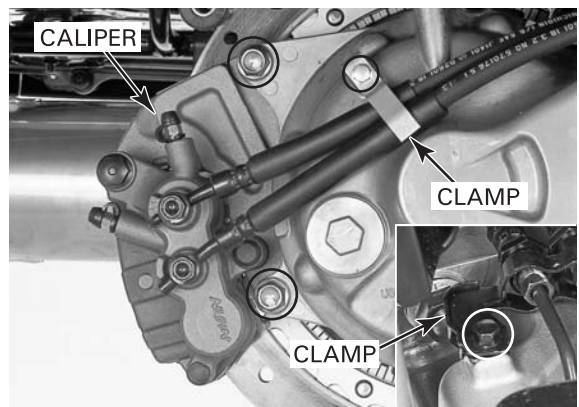

- two screws (using an impact driver - be careful not to damage the screw head)
- brake disc



## FINAL DRIVE

Remove the four nuts, washers and final drive assembly.  
Remove the two dowel pins.



## INSPECTION

Remove the joint shaft assembly from the pinion joint by pulling it. This will force the stopper ring at the joint shaft past the groove in the pinion joint.

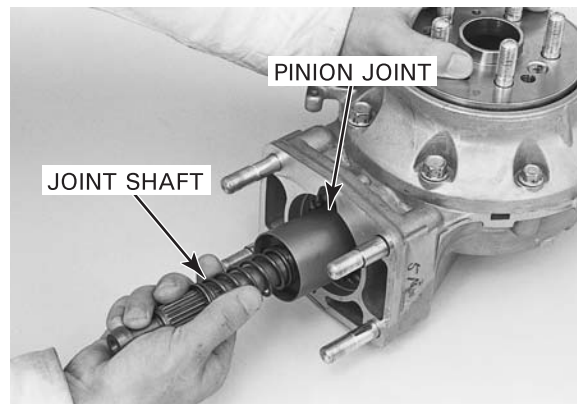

Check the dust seal for fatigue, wear or damage.  
Check the splines of the joint shaft for wear or damage.  
If the splines are damaged, check the pinion joint and drive shaft splines.

To remove the drive shaft, remove the swingarm (page 14-22).

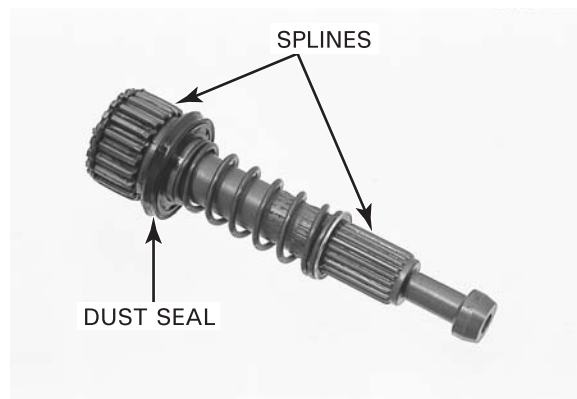

Turn the pinion joint and check that the pinion and ring gears turn smoothly and quietly without binding.

If the gears do not turn smoothly or quietly, the gears and/or bearing may be damaged or faulty. They must be checked after disassembly; replace faulty parts/ assemblies as required.

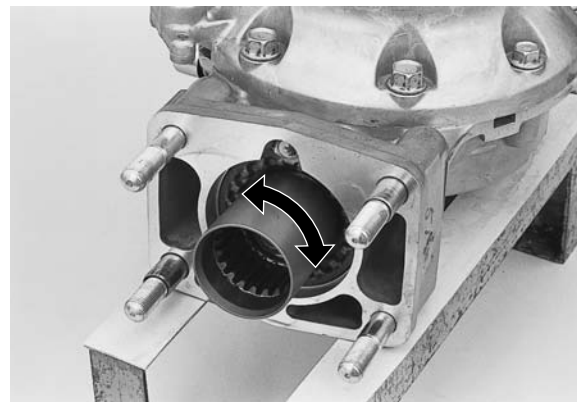

# FINAL DRIVE DISASSEMBLY/ INSPECTION

## BACKLASH INSPECTION

Before inspecting the backlash, modify the special tool at four places as shown. Be sure the modified areas on the plate fit properly around the stud bolts.

**TOOL:**

Holder plate

07924-9690103 or  
07924-9690101  
(modified)

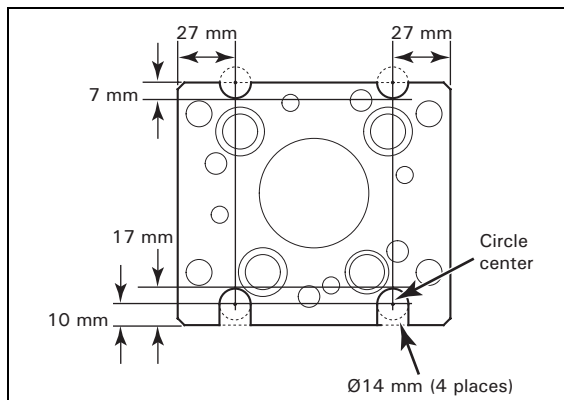

Set the final drive assembly in a vise.  
Install suitable washers onto the stud bolts of the filler hole side.  
Install the special tools onto the gear case and into the pinion joint to hold it.

**TOOLS:**

Pinon holder

Collar set "C"

Holder plate (modified)

07924-ME40010  
07924-ME40020  
07924-9690103 or  
07924-9690101  
(modified)

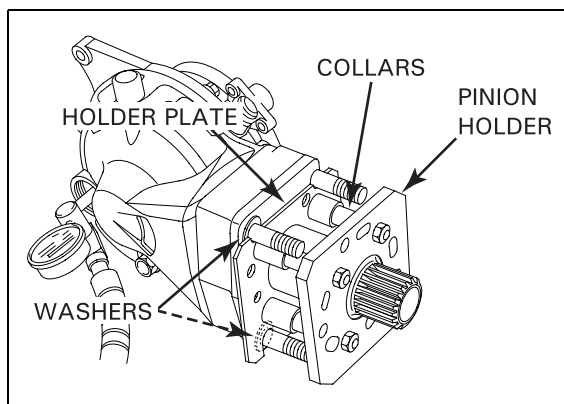

Remove the oil filler cap.  
Set a horizontal type dial indicator on the ring gear through the oil filler hole.  
Turn the ring gear back and forth to read the backlash.

**STANDARD: 0.05 – 0.15 mm (0.002 – 0.006 in)**

**SERVICE LIMIT: 0.30 mm (0.012 in)**

Remove the dial indicator. Turn the ring gear 120° and measure the backlash. Repeat this procedure once more.

Compare the difference of the three measurements.

**SERVICE LIMIT: 0.10 mm (0.004 in)**

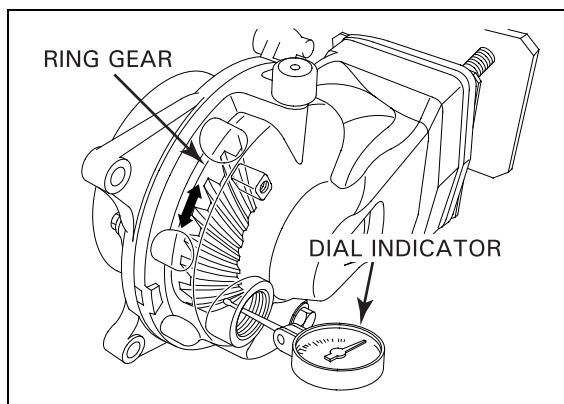

If the difference between the three measurements exceeds the service limit, it indicates that the bearing is not installed squarely, or the case is deformed.

Inspect the bearings and case.

If the backlash is excessive, replace the right ring gear shim with a thicker one.

If the backlash is too small, replace the right ring gear shim with a thinner one.

**NOTE:**

- Fifteen different shim thicknesses (from A to P) are available in increments of 0.06 mm (0.002 in). Select the shim from A to I.

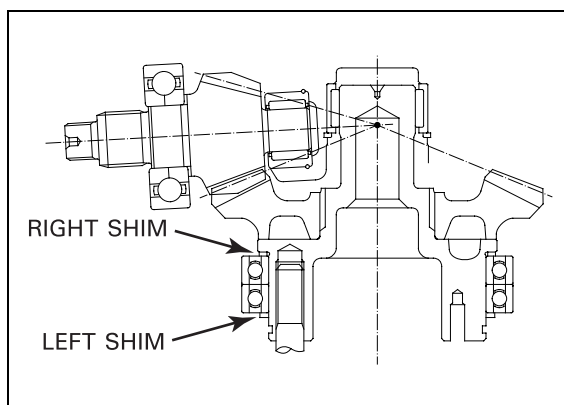

*Shims J to P may be used only for the left shim (page 12-14).*

## FINAL DRIVE

### RIGHT RING GEAR SHIMS:

A (thinnest): 1.82 mm (0.072 in)

D (standard): 2.00 mm (0.079 in)

I (thickest): 2.30 mm (0.091 in)

For ring gear shim replacement, see page 12-12.

### FINAL GEAR CASE SEPARATION

Loosen the eight cover bolts in a crisscross pattern in two or three steps and remove them.



Pry the cover at the prying points using a screwdriver and remove the case cover.

Check the ring gear needle bearing in the gear case for wear or damage.

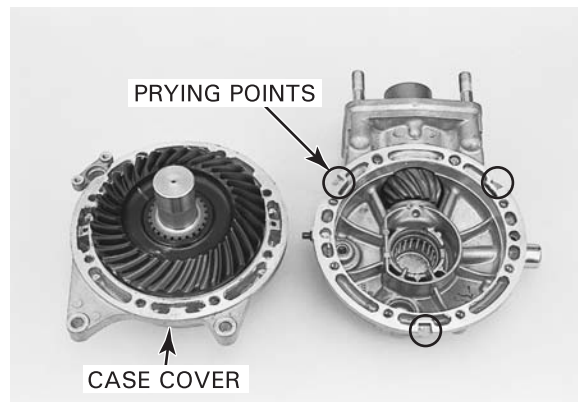

### GEAR TOOTH CONTACT PATTERN CHECK

*Keep dust and dirt out of the case and cover.*

Clean the sealing material off the mating surfaces of the gear case and cover, being careful not to damage them.

Apply a thin coat of Prussian Blue to the pinion gear teeth for the tooth contact pattern check.

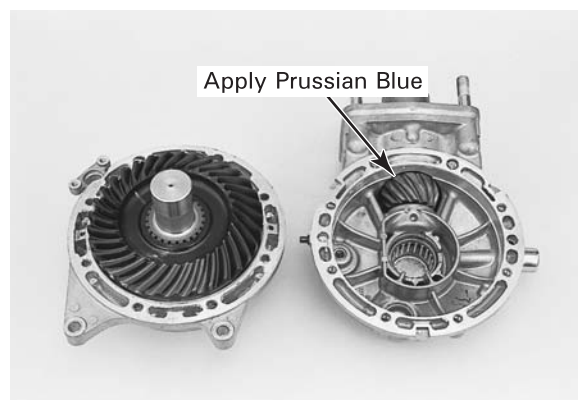

Install the case cover and tighten the bolts in several steps until the cover evenly touches the gear case. Then, while rotating the pinion gear, tighten the bolts to the specified torque in a crisscross pattern in several steps.

**TORQUE: 10 mm bolt: 62 N·m (6.3 kgf·m, 46 lbf·ft)**  
**8 mm bolt: 25 N·m (2.6 kgf·m, 19 lbf·ft)**

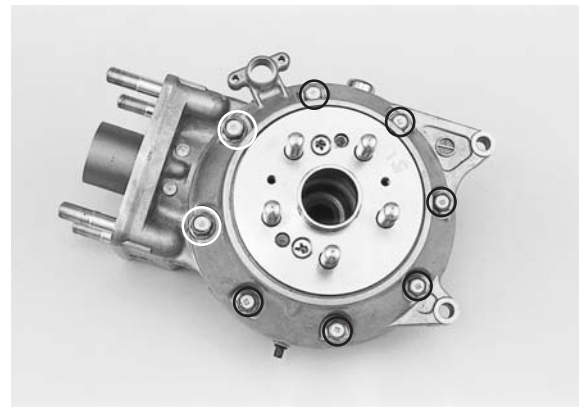

Remove the oil filler cap. Rotate the ring gear several times in both directions of rotation. Check the gear tooth contact pattern through the oil filler hole.

The pattern is indicated by the Prussian Blue applied to the pinion gear. Contact is normal if the Prussian Blue is transferred to the approximate center of each tooth and slightly towards the face.

If the patterns are not correct, remove and change the pinion shim with a suitable one.

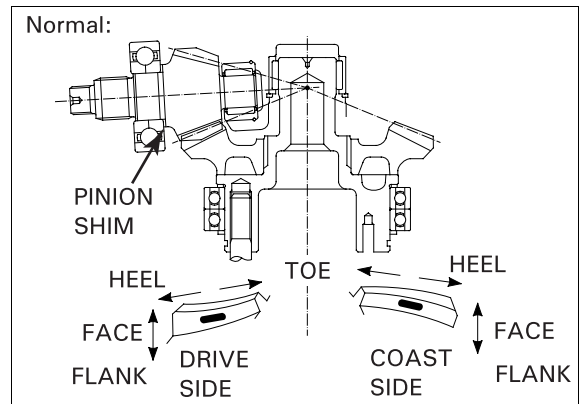

Replace the pinion gear shim with a thicker one if the contact pattern is too high, toward the face.

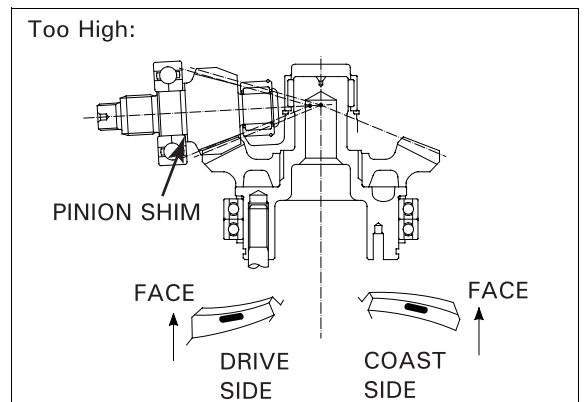

Replace the pinion gear shim with a thinner one if the contact pattern is too low, toward the flank.

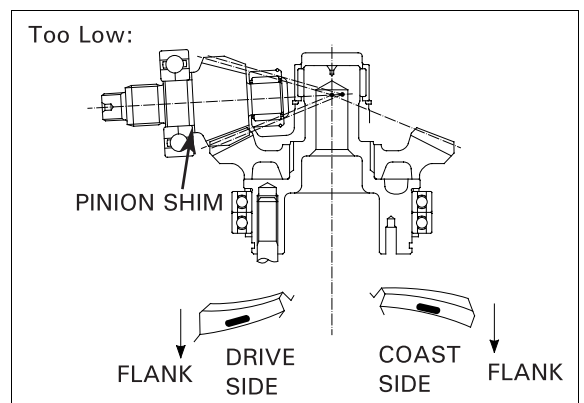

**NOTE:**

- Seven different shim thicknesses (from A to G) are available in increments of 0.06 mm (0.002 in).

**PINION SHIMS:**

**A (thinnest): 1.32 mm (0.052 in)**

**D (standard): 1.50 mm (0.059 in)**

**G (thickest): 1.68 mm (0.066 in)**

For pinion gear shim replacement, see page 12-14.



## RING GEAR BEARING/SHIM REPLACEMENT

Remove the following:

- two screws (using an impact driver – Be careful not to damage the screw head.)
- final side flange
- two dowel pins

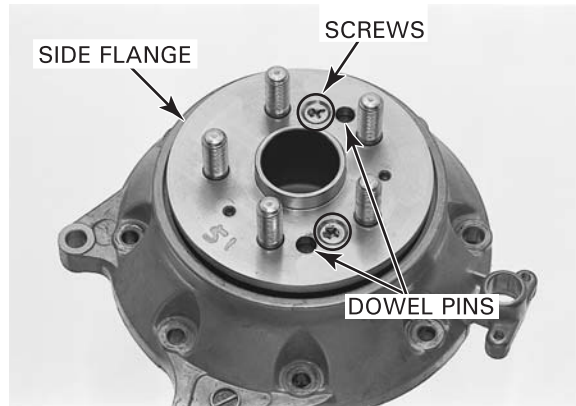

- oil seal
- O-ring
- left ring gear shim

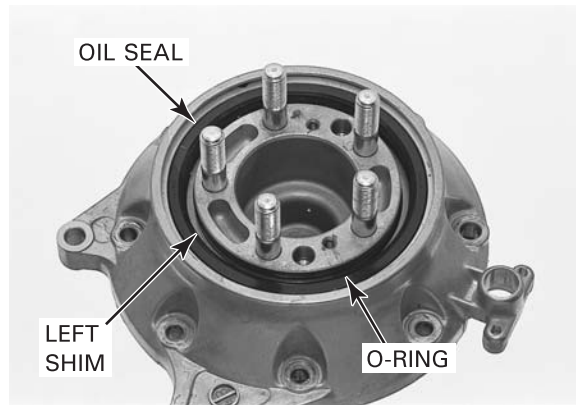

Press the ring gear out of the case cover using the special tools.

### TOOLS:

- |                               |                      |
|-------------------------------|----------------------|
| <b>Driver</b>                 | <b>07749-0010000</b> |
| <b>Attachment, 62 x 68 mm</b> | <b>07746-0010500</b> |

Remove the right ring gear shim.

Before removing the snap ring, be sure to wear safety glasses and take caution because the snap ring is under high tension.

Remove the snap ring from the gear case cover.

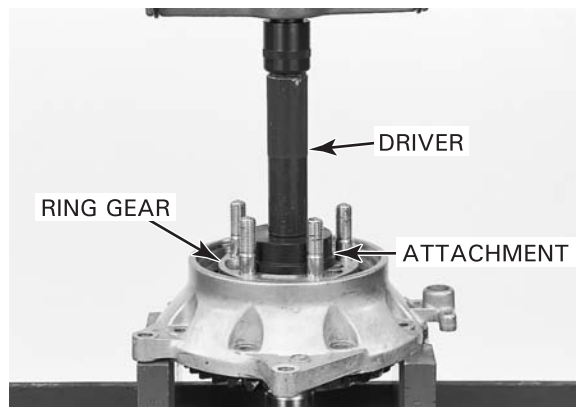

*Be sure to wear heavy gloves to avoid burns when handling the heated case cover. Do not use a torch to heat the case cover, this may cause warpage.*

Heat the case cover to 80°C (176°F) and drive the bearing out of the case cover.

Install a new bearing while the cover is still heated.

Install the snap ring into the cover groove with the chamfered (rolled) edge facing away from the bearing properly.

Install the ring gear (page 12-19).

### NOTE:

- When the gear set, pinion bearing, and/or gear case has been replaced, use a 2.00 mm (0.079 in) thick shim for initial reference.

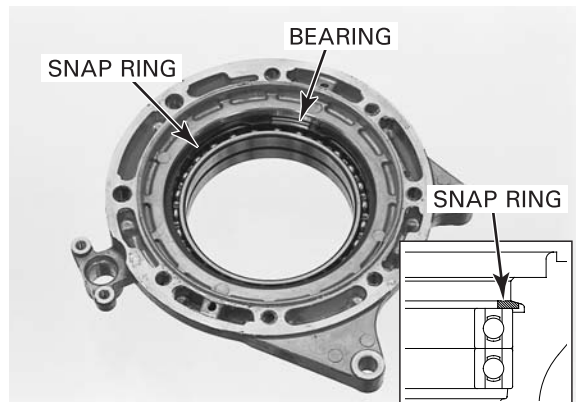



**PINION GEAR REMOVAL**

*Be careful not to damage the mating surface of the case.*

Place the gear case in a vise with soft jaws.  
Install the washers.  
Install the special tools.  
Remove the pinion joint nut.

*Place the washers under the holder plate (on the top and bottom stud bolts, on the oil drain bolt side) to compensate for the angle of the pinion shaft.*

**TOOLS:**

**Pinion holder**

**07924-ME40010**

**Collar set "C"**

**07924-ME40020**

**Holder plate (modified)**

**07924-9690103 or**

**07924-9690101**

**(modified)**

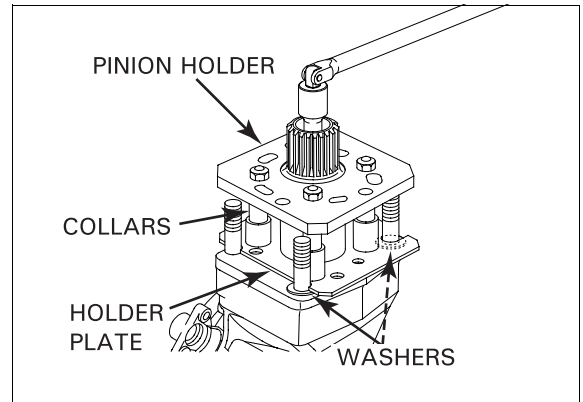

Remove the pinion joint.  
Remove the bolt and retainer lock tab.

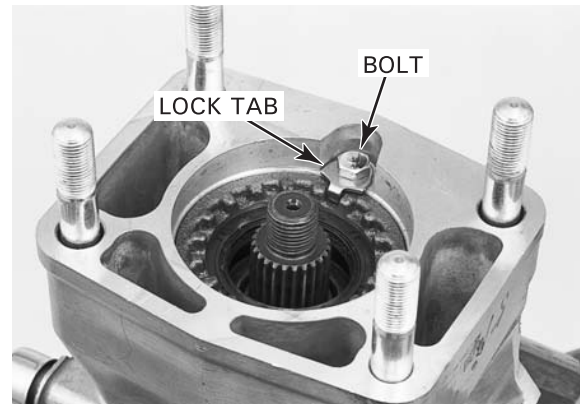

Remove the pinion retainer using the special tool.

**TOOL:**

**Retainer wrench**

**07910-4630100**

**Holder plate**

**07924-9690103 or**

**07924-9690101**

**(modified)**

**Attachment, 24 x 26 mm**

**07746-0010700**

**Attachment, 22 x 24 mm**

**07746-0010800**

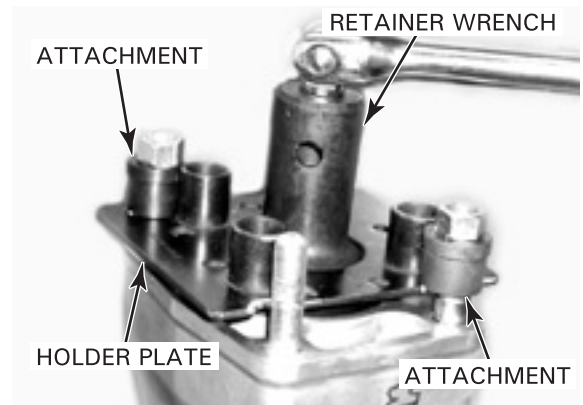

*Place the washer under the holder plate (on the top and bottom stud bolts, on the oil drain bolt side) to compensate for the angle of the pinion shaft.*

Install the washers.  
Install the special tools onto the pinion gear shaft and gear case.

**TOOLS:**

**Pinion puller base**

**07HMC-MM80110 or**

**07HMC-MM8011A**

**(U.S.A. only)**

**07931-ME40000 or**

**07931-ME4010B and**

**07931-HB3020A**

**(U.S.A. only)**

**07924-9690103 or**

**07924-969010**

**(modified)**

**Puller shaft**

**Holder plate**

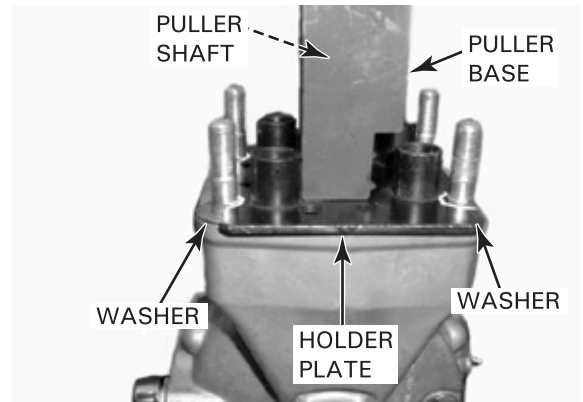

Pull the pinion gear assembly out of the gear case.  
Check the pinion needle bearing in the gear case for wear or damage.

## FINAL DRIVE

### PINION BEARING/SHIM REPLACEMENT

Pull the pinion bearing from the shaft with a commercially available bearing puller.

Remove the pinion shim.

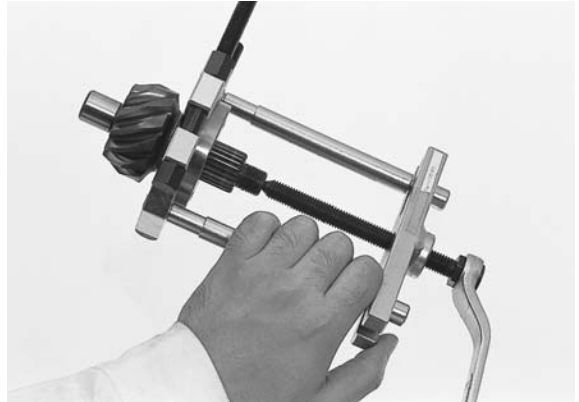

Install the shim and a new bearing onto the pinion gear.

**NOTE:**

- When the gear set, ring gear bearing, and/or gear case has been replaced, use a 1.50 mm (0.059 in) thick shim for initial reference.

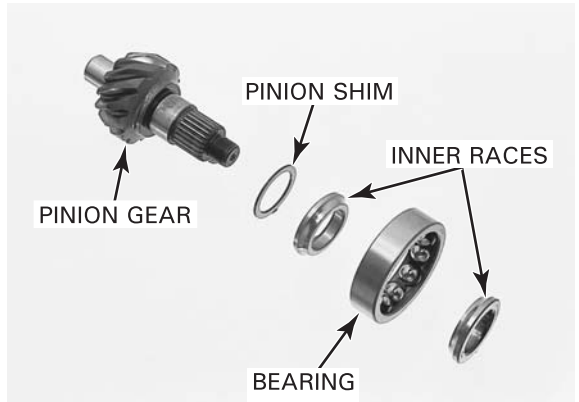

Drive the bearing using the special tools.

**TOOLS:**

**Driver, 40 mm I.D.**

**07746-0030100**

**Attachment, 25 mm I.D.**

**07746-0030200**

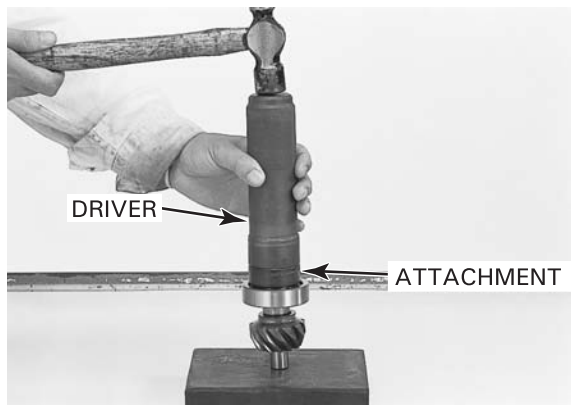

## CASE BEARING REPLACEMENT

### RING GEAR NEEDLE BEARING

Remove the snap ring from the gear case.

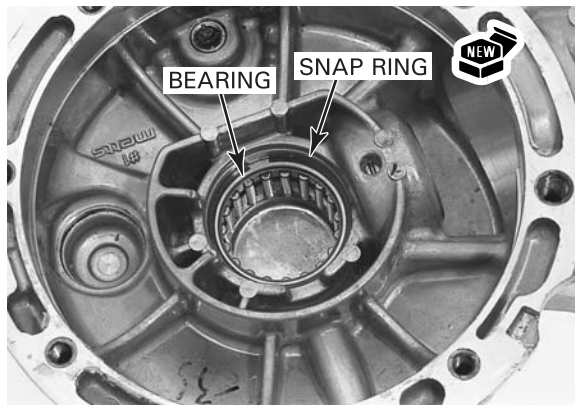

Remove the needle bearing using the special tools.

**TOOLS:**

**Bearing remover, 30 mm** 07936-8890200  
**Remover handle** 07936-3710100  
**Remover weight** 07741-0010201 or 07936-371020A or 07936-3710200 (U.S.A. only)

**U.S.A. only:**

**Adjustable bearing puller, 20-40 mm** 07736-A01000B or 07736-A01000A

**Slide hammer, 3/8" x 16 mm thread (commercially available in U.S.A.)**

Remove the bearing cage and bearings from the inside of the pinion bearing to allow the special tool to grip the bearing.

Drive new bearings in the case and cover using the special tools.

**TOOLS:**

**Driver** 07749-0010000  
**Attachment, 42 x 47 mm** 07746-0010300  
**Pilot, 30 mm** 07746-0040700

Install a new snap ring into the case groove securely.

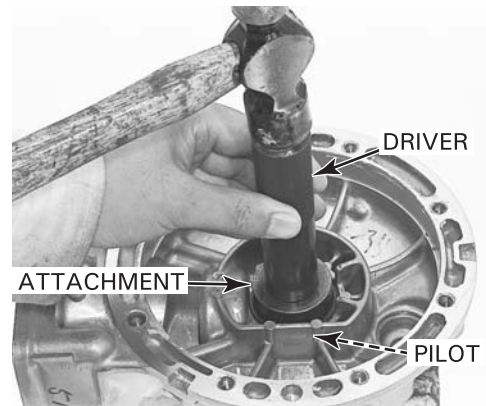
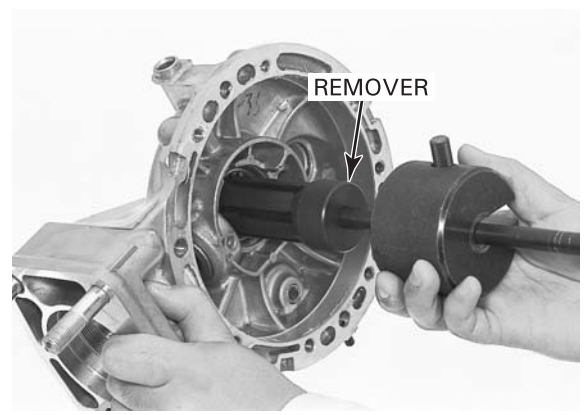

**PINION NEEDLE BEARING**

Remove the stopper ring by rotating it until the end of the stopper ring appears in the access hole.

Strike gently near the end of the ring with a punch to bend the end upward.

Grasp the end of the ring with needle-nose pliers and pull the stopper ring out through the access hole.

Heat the gear case to 80° C (176° F) and remove the needle bearing by using the special tools.

**TOOLS:**

**Bearing remover, 20 mm** 07936-3710600  
**Remover handle** 07936-3710100  
**Remover weight** 07741-0010201 or 07936-371020A or 07936-3710200 (U.S.A. only)

*Be sure to wear heavy gloves to avoid burns when handling the heated gear case. Using a torch to heat the gear case may cause warpage.*

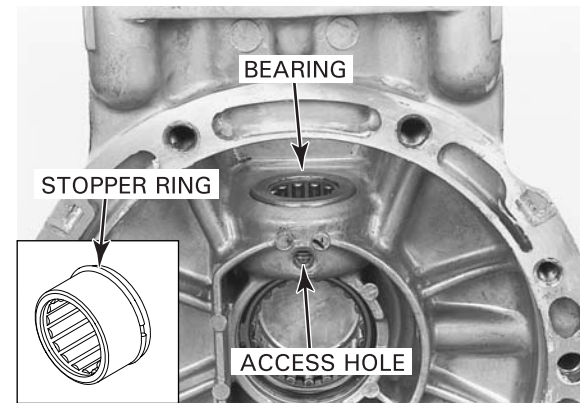

Remove the bearing cage and bearings from the inside of the pinion bearing to allow the special tool to grip the bearing.

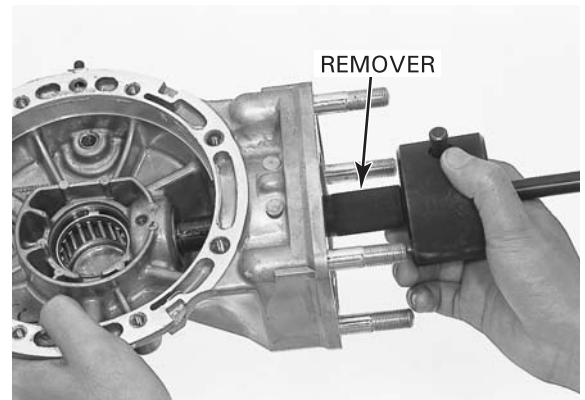

## FINAL DRIVE

---

Install the stopper ring into the groove securely.

Place the needle bearing in a freezer.

Heat the gear case to 80°C (176°F).

Remove the needle bearing from the freezer and drive it into the gear case using the special tools.

### TOOLS:

<b>Driver</b>	<b>07949-3710001</b>
<b>Attachment, 32 x 35 mm</b>	<b>07746-0010100</b>
<b>Pilot, 20 mm</b>	<b>07746-0040500</b>
<b>Differential bearing ring compressor, 35 mm</b>	<b>07ZME-MCAA100</b>

Make sure the stopper ring is securely set in the groove of the gear case.

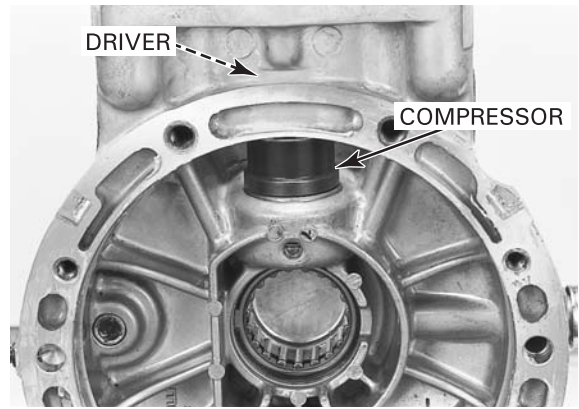

# FINAL DRIVE ASSEMBLY

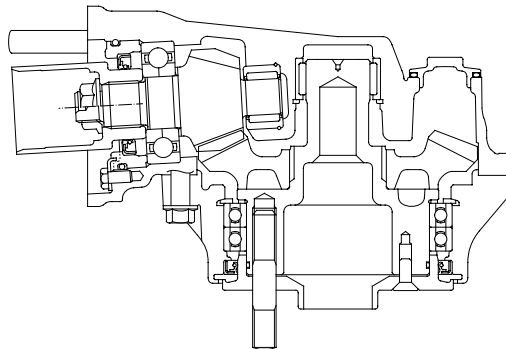
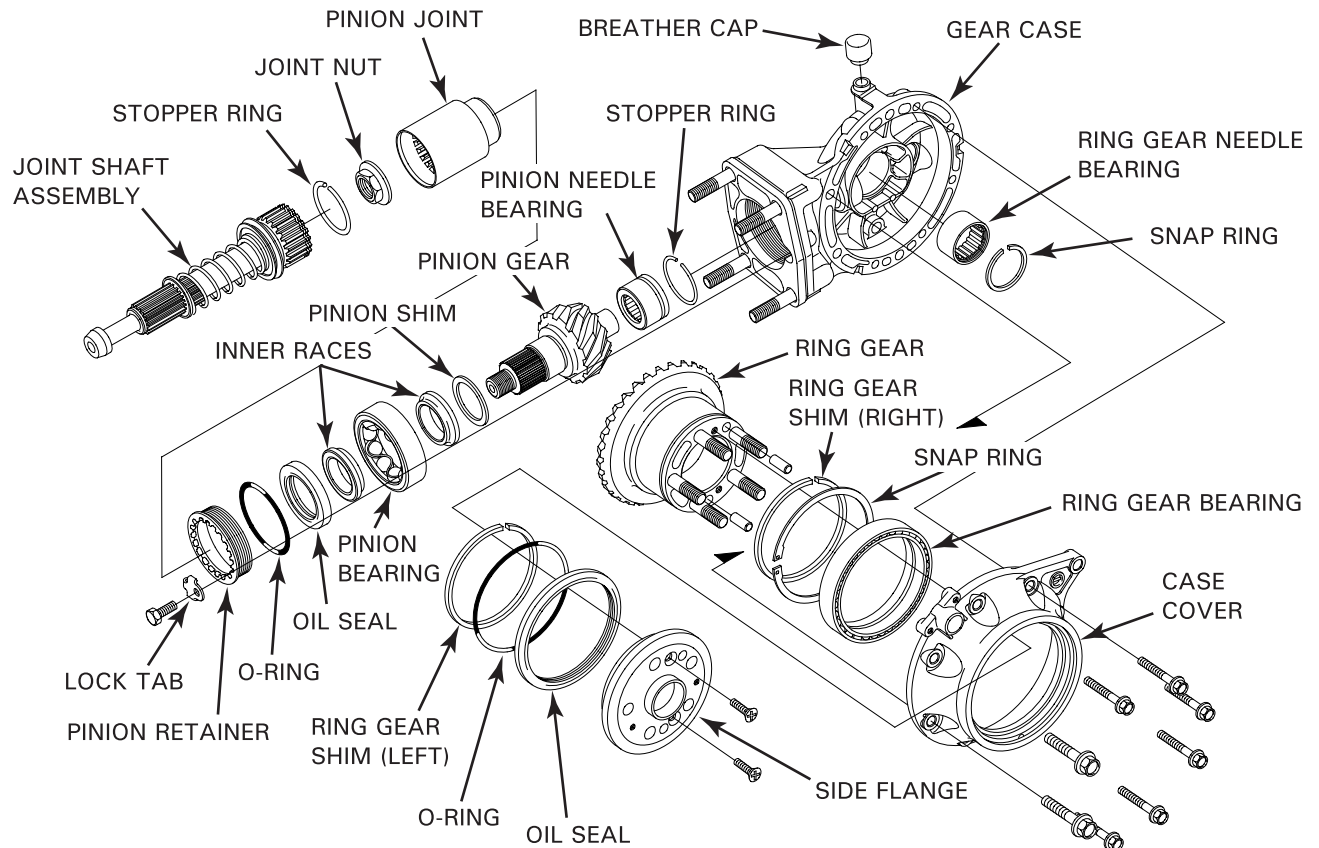

## PINION GEAR INSTALLATION

Drive the pinion gear assembly into the gear case using the special tool.

**TOOL:**

**Oil seal driver**

**07948-SC20200**

**Main bearing driver attachment**

**07946-ME90200**

**(U.S.A. only)**

**Driver**

**07749-0010000**

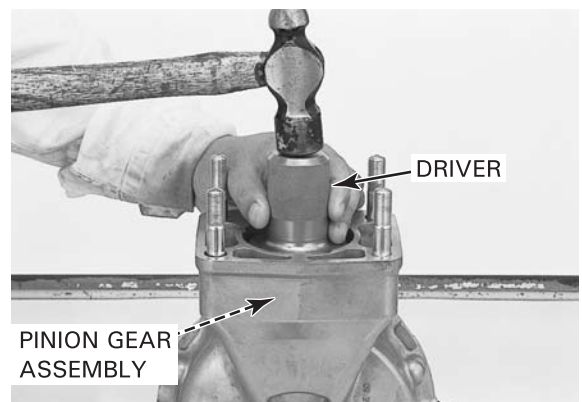



## FINAL DRIVE

Drive a new oil seal into the pinion retainer with the flat side facing down using the special tool.

### TOOLS:

**Driver** 07749-0010000

**Attachment, 52 x 55 mm** 07746-0010400

Pack grease into the seal lip cavity.

Coat a new O-ring with grease and install it into the retainer groove.

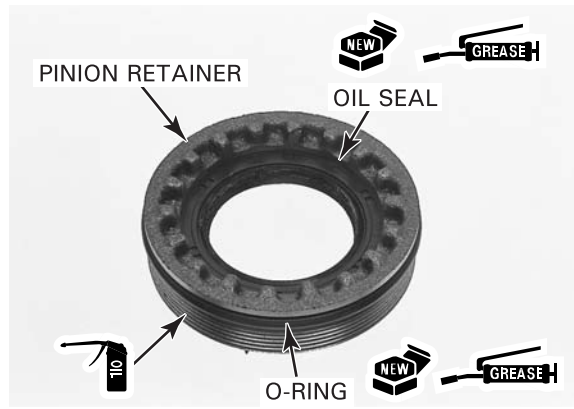

Apply engine oil the threads of the pinion retainer.  
Install the retainer into the gear case and tighten it.

### TOOL:

**Retainer wrench** 07910-4630100

**Holder plate** 07924-9690103 or  
07924-9690101  
(modified)

**Attachment, 24 x 26 mm** 07746-0010700

**Attachment, 22 x 24 mm** 07746-0010800

**TORQUE: 147 N·m (15.0 kgf·m, 108 lbf·ft)**

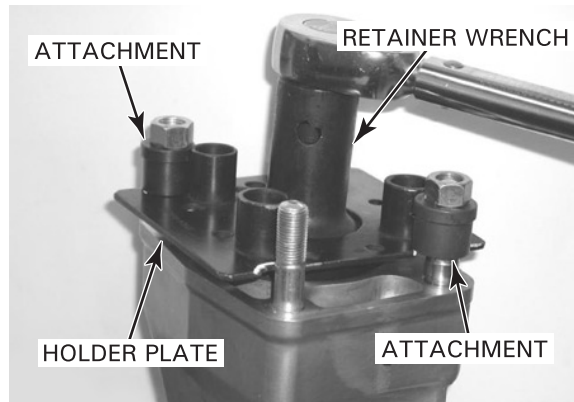

*The lock tab is available in the two types (A and B) shown.*

Install the lock tab, depending on the position of the pinion retainer grooves in relation to the lock tab and tighten the bolt.

**TORQUE: 10 N·m (1.0 kgf·m, 7 lbf·ft)**

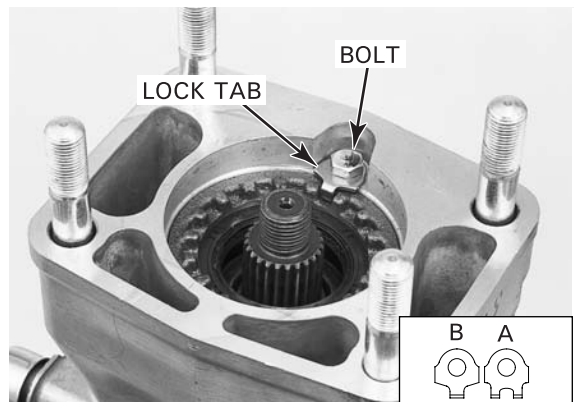

Clean the threads of the pinion gear shaft and pinion joint nut thoroughly.

Apply locking agent to the joint nut threads and install the pinion joint and joint nut onto the pinion gear shaft.

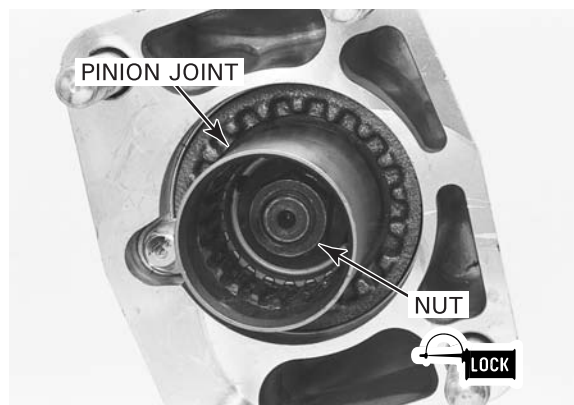



Place the washers under the holder plate (on the top and bottom stud bolts, on the oil drain bolt side) to compensate for the angle of the pinion shaft.

Install the washers.  
Install the special tools.  
Tighten the pinion joint nut.

**TOOLS:**  
**Pinon holder**  
**Collar set "C"**  
**Holder plate**

**07924-ME40010**  
**07924-ME40020**  
**07924-9690103 or**  
**07924-9690101**  
**(modified)**

**TORQUE: 108 N·m (11.0 kgf·m, 80 lbf·ft)**

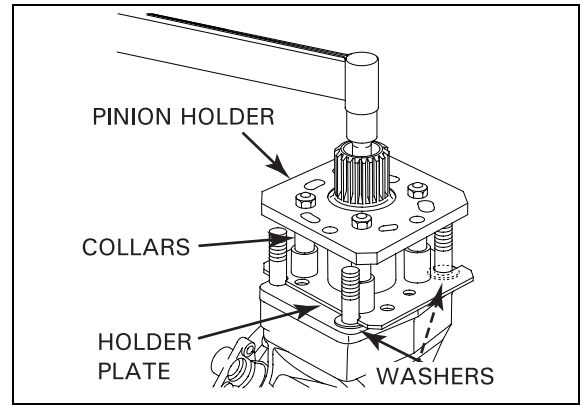

**RING GEAR INSTALLATION**

Check that the ring gear stud bolts are tight. If any are loose, remove them, clean their threads with contact cleaner, then install using locking agent.

After installing, be sure to measure the distance from the top of each stud to the ring gear surface as shown.

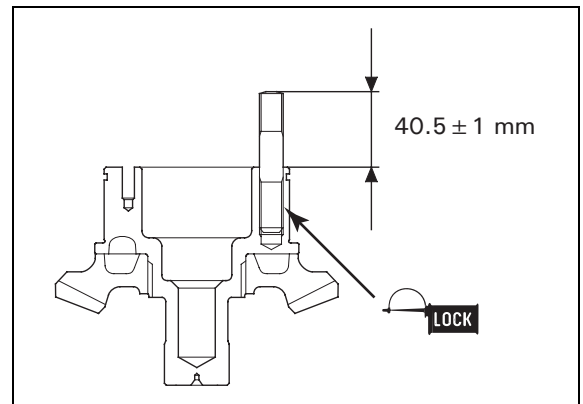

Install the right side shim onto the ring gear.

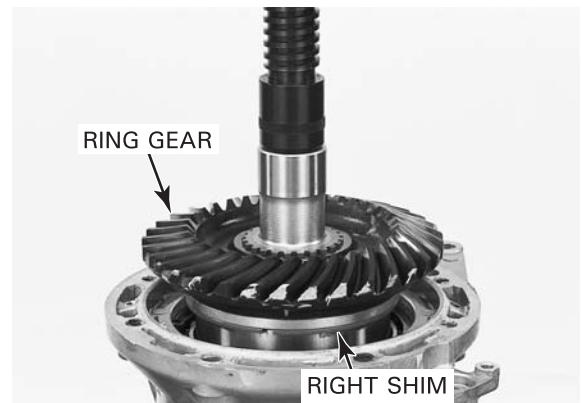

Support the bearing inner race with the special tool and press the ring gear into the case cover.

**TOOL:**  
**Assembly base** **07ZMF-MCAA300**

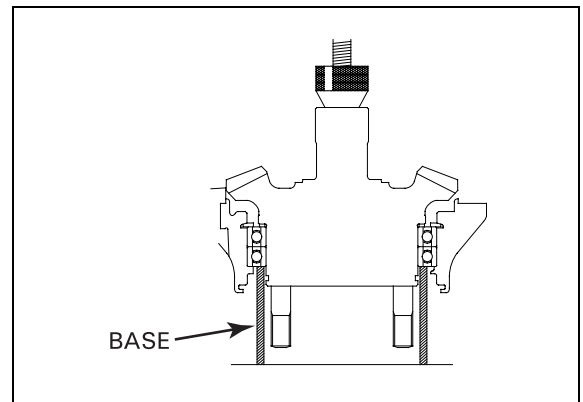

## FINAL DRIVE

Select the left side shim as follows.  
Measure the height of the ring gear boss from the bearing (A) and the depth of the side flange from the flange end (B) as shown, and record them.

Calculate the shim thickness using the equation below. The correct shim is nearly this dimension

$$\text{New left shim thickness} = A - B + 0.2 \text{ mm}$$

NOTE:

- Fifteen different shim thicknesses (from A to P) are available in increments of 0.06 mm (0.002 in).

### LEFT RING GEAR SHIMS:

**A (thinnest): 1.82 mm (0.072 in)**

**D (standard): 2.00 mm (0.079 in)**

**P (thickest): 2.66 mm (0.105 in)**

Select the left side shim and install it onto the bearing.

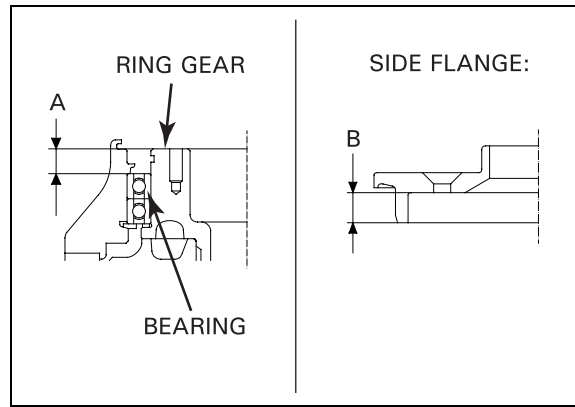

Coat a new O-ring with grease and install it into the groove in the ring gear boss.

Pack grease into the oil seal lip cavity.  
Install the oil seal into the case cover until it is flush with the cover edge (page 12-19).

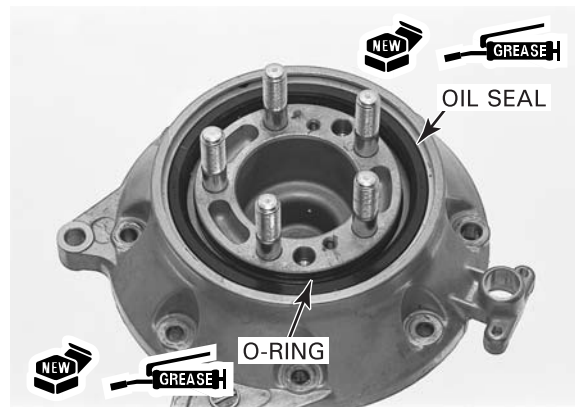

Never allow foreign materials to get into the clearance between the side flange and ring gear boss.

Apply grease to the inner side wall of the side flange as shown.

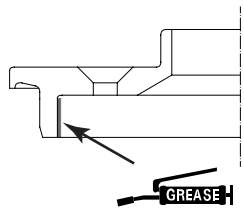

Install the two dowel pins and the side flange.  
Install new screws and tighten them.

**TORQUE: 9 N-m (0.9 kgf-m, 6.5 lbf-ft)**

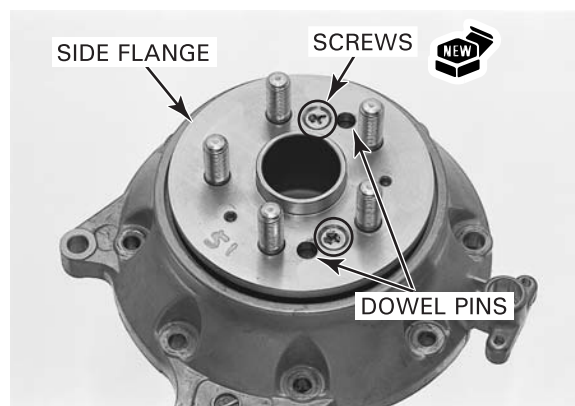

## FINAL GEAR CASE ASSEMBLY

**NOTE:**

- When the gear set, bearing, and/or gear case has been replaced, check the tooth contact pattern (page 12-10) and gear backlash (page 12-9).

*Keep dust and dirt out of the case and cover.*

Clean the mating surface of the gear case and cover, being careful not to damage them.

Remove the breather cap, being careful not to deform it.

Blow compressed air through the breather hole in the gear case.

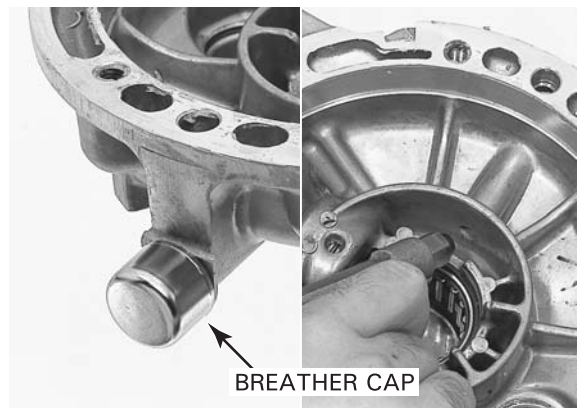

Apply liquid sealant to the mating surface of the gear case.

Install the case cover onto the gear case.

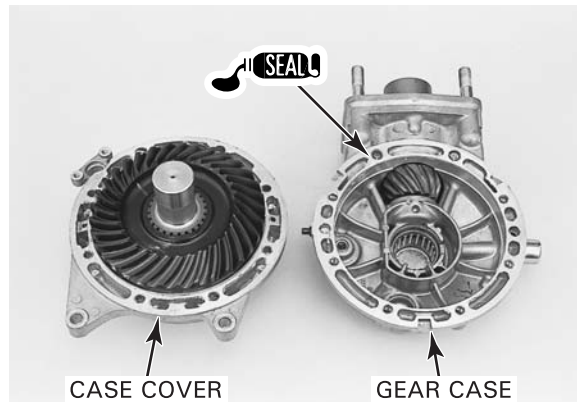

Apply locking agent to the threads of the case cover bolts.

Install the bolts and tighten them in several steps until the cover evenly touches the gear case. Then, while rotating the pinion gear, tighten the bolts to the specified torque in a crisscross pattern in several steps.

**TORQUE: 10 mm bolt: 62 N·m (6.3 kgf·m, 46 lbf·ft)**  
**8 mm bolt: 25 N·m (2.6 kgf·m, 19 lbf·ft)**

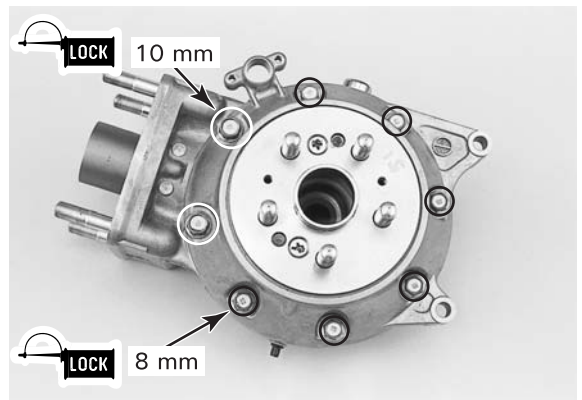

Check that the gear assembly turns smoothly without binding.

Measure the gear assembly preload.

**STANDARD:**

**0.2 – 1 N·m (2 – 10 kgf·cm, 1.7 – 8.7 lbf·in)**

If the preload reading does not fall within the limit, check the bearings for proper installation.

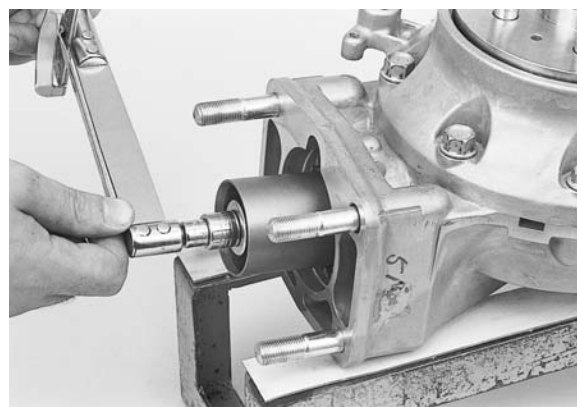

## FINAL DRIVE

### FINAL DRIVE INSTALLATION

Check that the gear case stud bolts are tight.  
If any are loose, remove them, clean their threads with contact cleaner, then install using locking agent.

After installing, be sure to measure the distance from top of each stud to the gear case surface as shown.

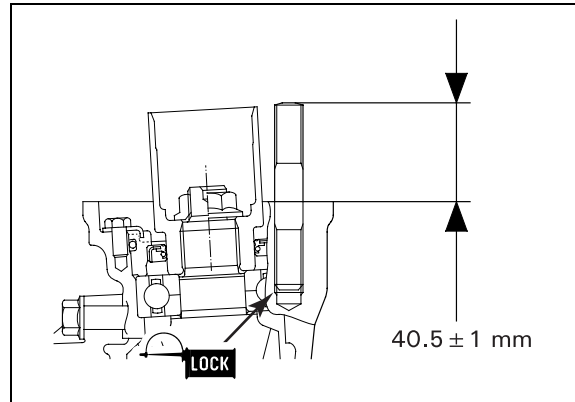

Install a new stopper ring into the groove in the joint shaft splines.

Install a new dust seal onto the joint shaft with the flat side facing the spring and pack molybdenum disulfide grease into the seal lip cavity.

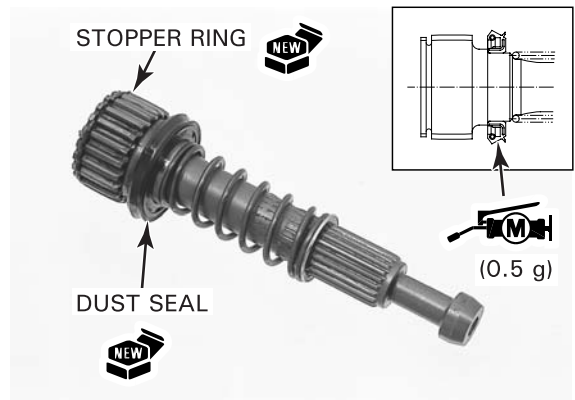

Apply molybdenum disulfide grease to the pinion joint splines.

Install the joint shaft assembly into the pinion joint until the stopper ring on the shaft seats in the pinion joint groove.

Make sure the stopper ring is seated properly by pulling on the joint shaft lightly.

Clean the mating surfaces of the swingarm and final gear case.

Install the two dowel pins.

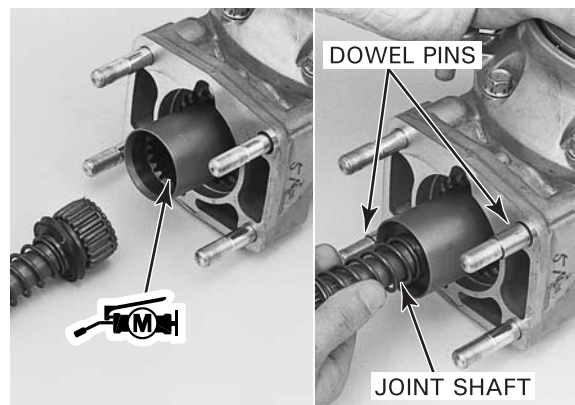

Apply molybdenum disulfide grease to the joint shaft splines.

Install the final drive assembly, while aligning the splines of the joint shaft and drive shaft.

Install the four washers and nuts, and tighten them.

**TORQUE: 88 N·m (9.0 kgf·m, 65 lbf·ft)**

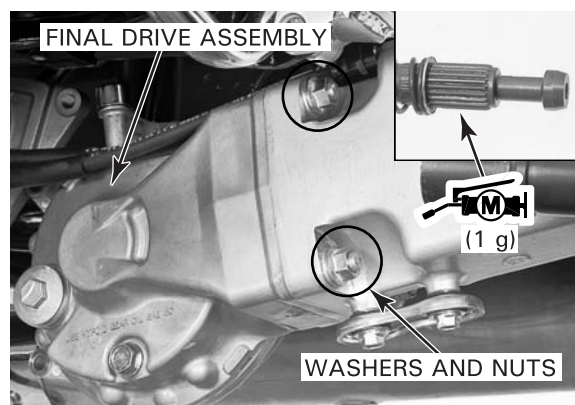

Clean the mating surfaces of the brake disc and final drive assembly, and make sure that no foreign materials enter the final drive assembly.

Install the brake disc onto the stud bolts.

Install new screws and tighten them.

**TORQUE: 9 N·m (0.9 kgf·m, 6.5 lbf·ft)**



Install the brake caliper with new bolts and tighten them.

**TORQUE: 45 N·m (4.6 kgf·m, 33 lbf·ft)**

Install the brake pipe clamp bolt and tighten it.

**TORQUE: 12 N·m (1.2 kgf·m, 9 lbf·ft)**

'01 - '03 only: Install the brake hose clamp onto the gear case and tighten the bolt.

**TORQUE: 12 N·m (1.2 kgf·m, 9 lbf·ft)**

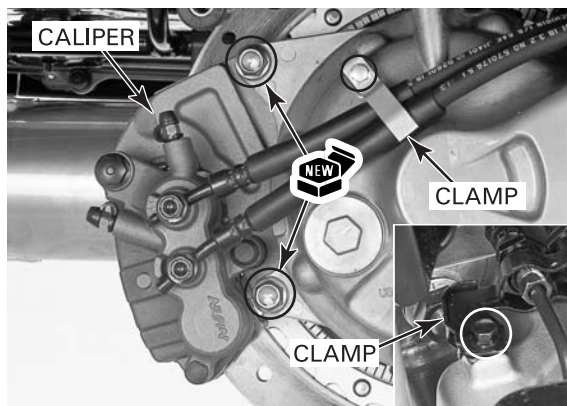

'01 - '03: Install the wheel speed sensor and tighten the bolts.

**TORQUE: 12 N·m (1.2 kgf·m, 9 lbf·ft)**

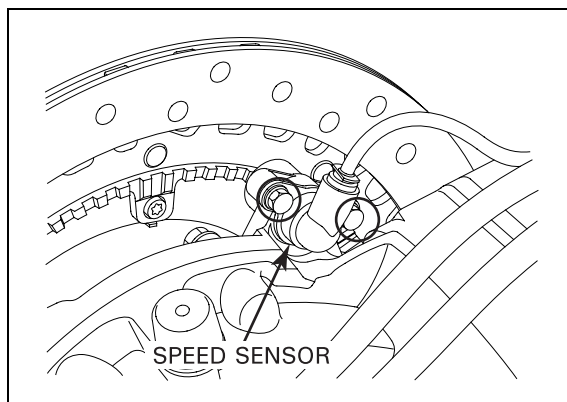

After '03: Install the wheel speed sensor, brake hose guide and tighten the bolts.

**TORQUE: 12 N·m (1.2 kgf·m, 9 lbf·ft)**

Install the following:

- rear wheel (page 14-14)
- right muffler (page 2-20)

Fill the gear case with the recommended oil if it was disassembled (page 3-16).

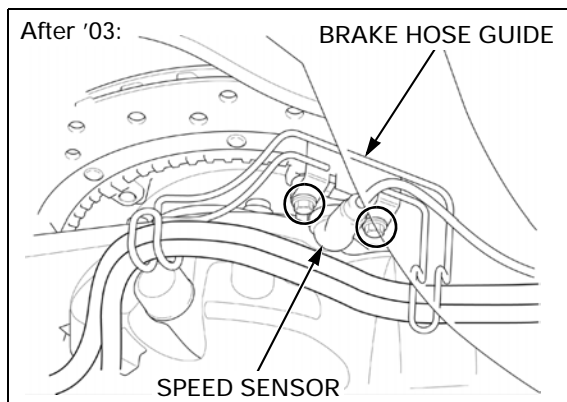

---

**MEMO**

---



# 13. FRONT WHEEL/SUSPENSION/STEERING

---

COMPONENT LOCATION .....	13-2	FRONT WHEEL .....	13-16
SERVICE INFORMATION .....	13-3	FORK .....	13-24
TROUBLESHOOTING .....	13-6	STEERING STEM .....	13-41
HANDLEBAR .....	13-7		

# FRONT WHEEL/SUSPENSION/STEERING

## COMPONENT LOCATION

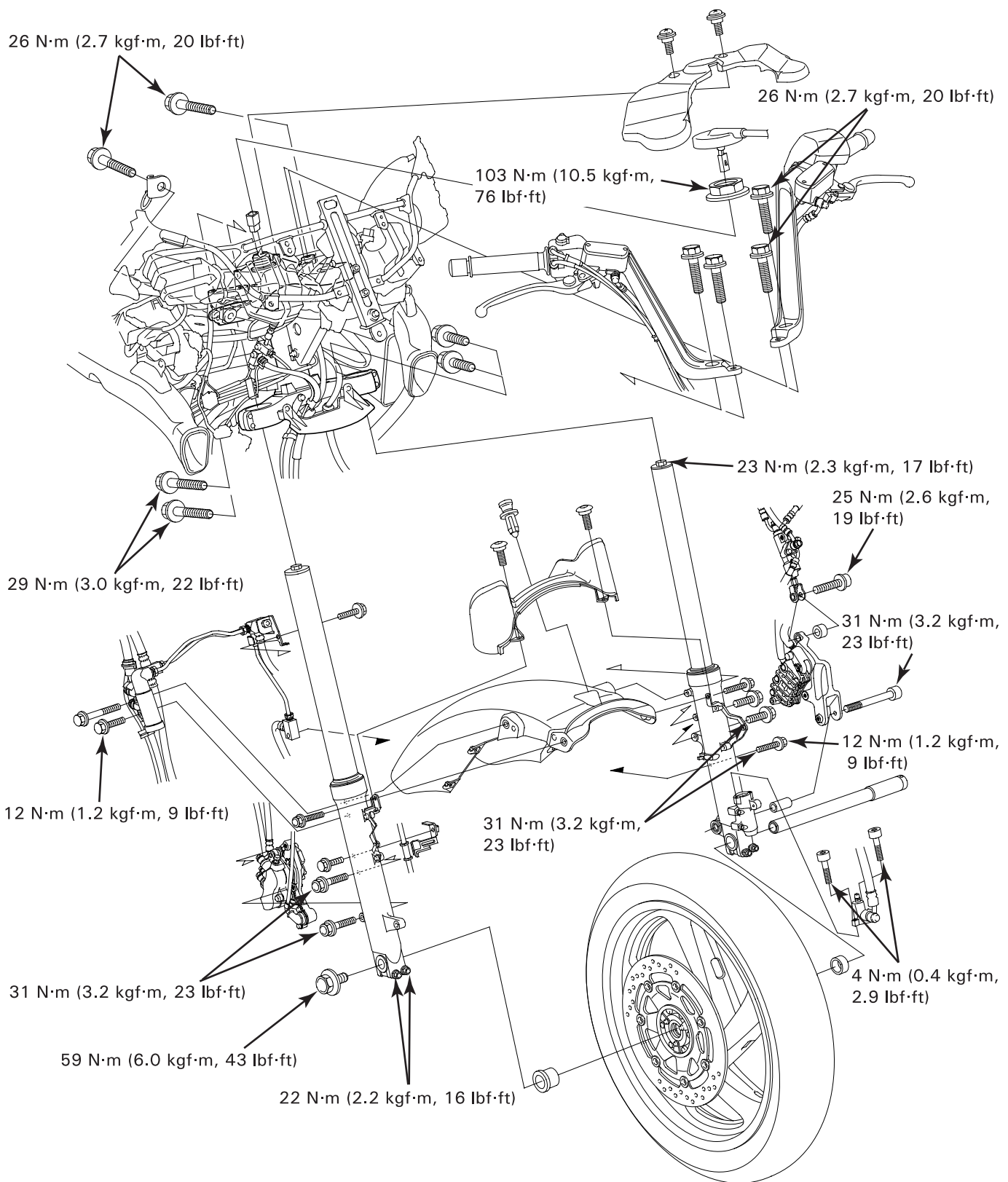

## SERVICE INFORMATION

### GENERAL

- Riding on damaged rims impairs safe operation of the vehicle.
- A contaminated brake disc or pad reduces stopping power. Discard contaminated pads and clean a contaminated disc with a high quality brake degreasing agent.
- A hoist or equivalent is required to support the motorcycle when servicing the front wheel, fork and steering stem.
- After installing the front wheel, perform the air gap inspection (page 16-29).
- Refer to section 15 for hydraulic brake system service.

### SPECIFICATIONS

Unit: mm (in)





ITEM		STANDARD	SERVICE LIMIT
Minimum tire tread depth		–	1.5 (0.06)
Cold tire pressure	Driver only	250 kPa (2.50 kgf/cm <sup>2</sup> , 36 psi)	–
	Driver and passenger	250 kPa (2.50 kgf/cm <sup>2</sup> , 36 psi)	–
Axle runout		–	0.20 (0.008)
Wheel rim runout	Radial	–	2.0 (0.08)
	Axial	–	2.0 (0.08)
Wheel balance weight		–	60 g (2.1 oz) max.
Fork	Spring free length		335.3 (13.20)
	Tube runout		–
	Recommended fluid		Fork fluid
	Fluid level		128 (5.0)
	Fluid capacity	Left	529 ± 2.5 cm <sup>3</sup> (17.9 ± 0.08 US oz, 18.6 ± 0.09 Imp oz)
Right		485 ± 2.5 cm <sup>3</sup> (16.4 ± 0.08 US oz, 17.1 ± 0.09 Imp oz)	–
Steering head bearing pre-load		8.8 – 13.7 N (0.9 – 1.4 kgf, 2.0 – 3.1 lbf)	–

### TORQUE VALUES



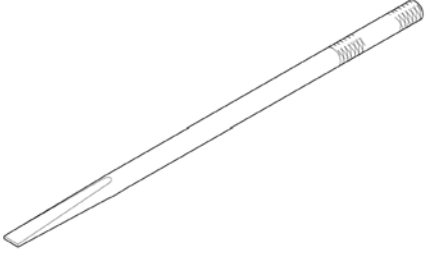

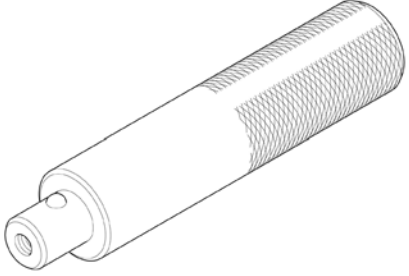
Handlebar weight mounting screw	10 N·m (1.0 kgf·m, 7 lbf·ft)	ALOC screw: replace with a new one.
Handlebar mounting bolt	26 N·m (2.7 kgf·m, 20 lbf·ft)	
Front brake disc bolt	20 N·m (2.0 kgf·m, 14 lbf·ft)	ALOC bolt: replace with a new one.
Front pulser ring bolt (ABS model only)	8 N·m (0.8 kgf·m, 5.8 lbf·ft)	ALOC bolt: replace with a new one.
Front axle bolt	59 N·m (6.0 kgf·m, 43 lbf·ft)	
Front axle holder bolt	22 N·m (2.2 kgf·m, 16 lbf·ft)	
Fork center bolt	20 N·m (2.0 kgf·m, 14 lbf·ft)	Apply locking agent to the threads.
Fork damper lock nut (right fork only)	20 N·m (2.0 kgf·m, 14 lbf·ft)	
Fork cap	23 N·m (2.3 kgf·m, 17 lbf·ft)	
Anti-dive plunger case bolt	4 N·m (0.4 kgf·m, 2.9 lbf·ft)	ALOC bolt: replace with a new one.
Fork top bridge pinch bolt	26 N·m (2.7 kgf·m, 20 lbf·ft)	
Fork bottom bridge pinch bolt	29 N·m (3.0 kgf·m, 22 lbf·ft)	
Steering bearing adjustment nut	27 N·m (2.8 kgf·m, 20 lbf·ft)	Apply oil to the threads and seating surface.
Steering stem nut	103 N·m (10.5 kgf·m, 76 lbf·ft)	
Delay valve mounting bolt	12 N·m (1.2 kgf·m, 9 lbf·ft)	
Right front brake caliper mounting bolt	31 N·m (3.2 kgf·m, 23 lbf·ft)	ALOC bolt: replace with a new one.
Secondary master cylinder mounting bolt	31 N·m (3.2 kgf·m, 23 lbf·ft)	ALOC bolt: replace with a new one.
Left front brake caliper lower pivot bolt	31 N·m (3.2 kgf·m, 23 lbf·ft)	ALOC bolt: replace with a new one.
Left front brake caliper-to-secondary master cylinder joint bolt	25 N·m (2.6 kgf·m, 19 lbf·ft)	ALOC bolt: replace with a new one.
Brake hose joint attaching bolt	12 N·m (1.2 kgf·m, 9 lbf·ft)	
Brake hose clamp bolt	12 N·m (1.2 kgf·m, 9 lbf·ft)	

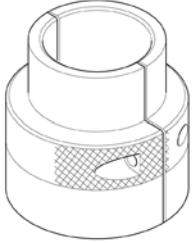
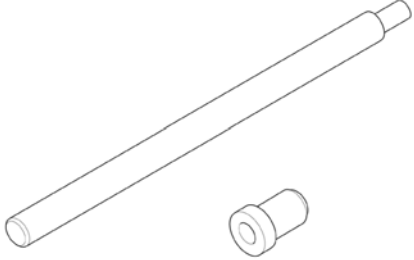
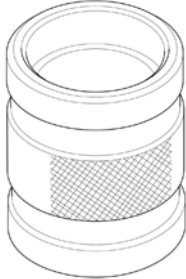
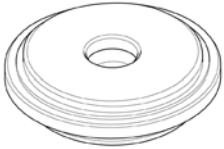
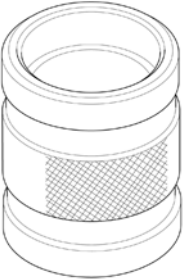
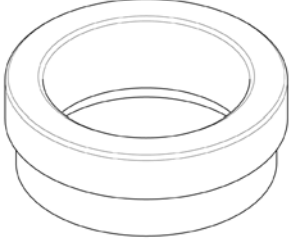
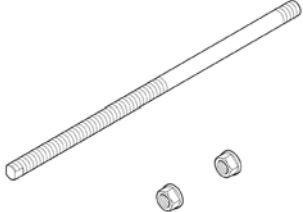
# FRONT WHEEL/SUSPENSION/STEERING

## TOOLS

<p>Bearing remover shaft 07GGD-0010100</p> 	<p>Bearing remover head, 20 mm 07746-0050600</p> 	<p>Driver 07749-0010000</p> 
<p>Attachment, 42 x 47 mm 07746-0010300</p> 	<p>Pilot, 20 mm 07746-0040500</p> 	<p>Fork seal driver 07KMD-KZ30100</p>  <p>07KMD-KZ3010A (U.S.A. only)</p>
<p>Needle bearing remover 07946-KA50000</p> 	<p>Steering stem socket 07916-3710101</p>  <p>or 07916-3710100</p>	<p>Main bearing driver attachment 07946-ME90200</p> 
<p>Fork seal driver weight 07947-KA50100</p> 	<p>Oil seal driver 07965-MA60000</p> 	<p>Installer shaft 07VMF-KZ30200</p> 

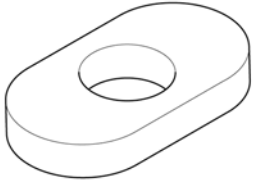
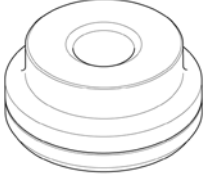
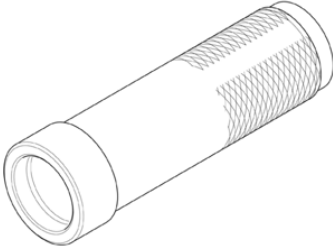
# FRONT WHEEL/SUSPENSION/STEERING

<p>Installer attachment A 07VMF-MAT0100</p> 	<p>Remover attachment A 07VMF-MAT0300</p> 	<p>Remover attachment B 07VMF-MAT0400</p> 
<p>Installer attachment B 07ZMF-MCAA100</p> 	<p>Inner driver handle, 40 mm 07746-0030100</p> 	<p>Attachment, 35 mm 07746-0030400</p> 

### TROUBLESHOOTING

#### Hard steering

- Steering bearing adjustment nut too tight
- Worn or damaged steering head bearings
- Worn or damaged steering head bearing races
- Bent steering stem
- Insufficient tire pressure
- Faulty front tire

#### Steers to one side or does not track straight

- Bent fork leg
- Damaged steering head bearings
- Loose steering head bearings
- Bent frame
- Worn wheel bearings
- Bent front axle
- Worn swingarm pivot component (section 14)

#### Front wheel wobbling

- Bent rim
- Worn wheel bearings
- Faulty tire
- Unbalanced tire and wheel

#### Soft suspension

- Weak fork spring
- Low fluid level in fork
- Insufficient fluid weight (low viscosity)
- Low tire pressure

#### Hard suspension

- High tire pressure
- Bent fork tube
- Fork slider binds
- High fluid level in fork leg
- Incorrect fluid weight (high viscosity)
- Clogged fork fluid passage
- Clogged anti-dive orifice

#### Front suspension noisy

- Loose fork fasteners
- Insufficient fluid weight (low viscosity)

#### Wheel turns hard

- Faulty wheel bearings
- Bent front axle
- Brake drag



# HANDLEBAR

## LEFT HANDLEBAR REMOVAL

Remove the meter panel (page 2-7).

Remove the two screws and handlebar center cover.

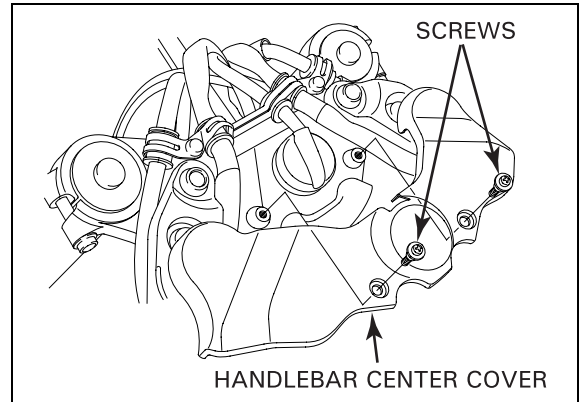

Hold the handlebar weight and remove the mounting screw and the weight.



Remove the holder cap from the clutch master cylinder holder bolts.



Disconnect the clutch switch connectors.  
Disconnect the clutch cruise switch connectors.

*Keep the clutch reservoir upright to prevent air from entering the hydraulic system.*

Remove the two bolts, holder and the clutch master cylinder assembly.

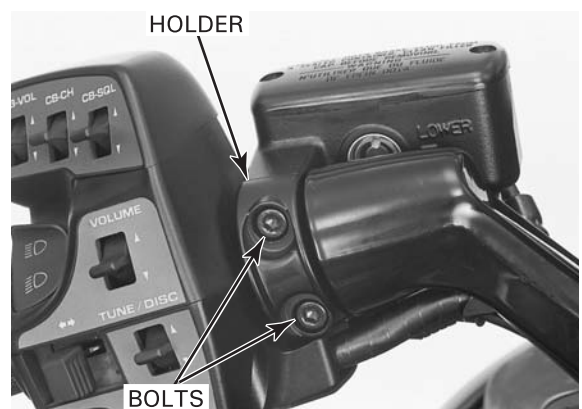

## FRONT WHEEL/SUSPENSION/STEERING

Remove the left handlebar mounting bolts.



Remove the two screws and handlebar setting plate.

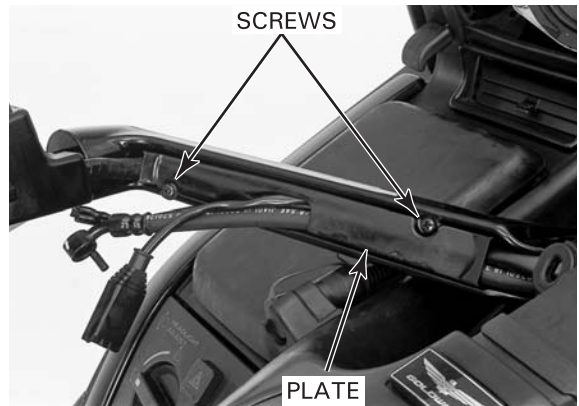

Remove the two screws from the left handlebar switch.

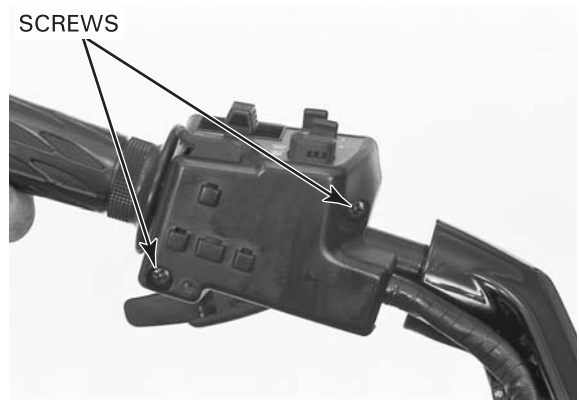

Remove the screw, setting plate and the left handlebar switch.  
Remove the left handlebar grip.

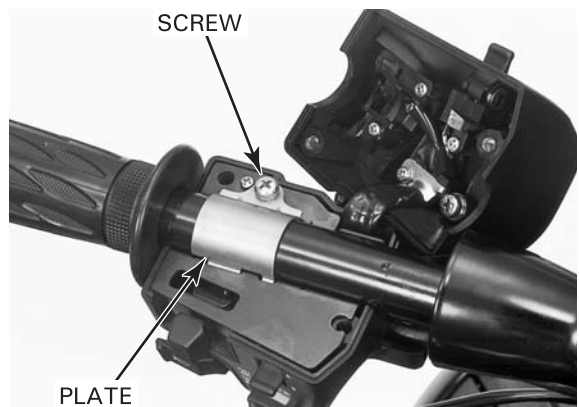

**LEFT HANDLEBAR INSTALLATION**

Clean the inside surface of the left handlebar grip and the outside surface of the handlebar. Apply Honda Bond A or equivalent to the inside surface of the left handlebar grip and to the outside surface of the left handlebar. Wait 3 – 5 minutes and install the grip.

*Allow the adhesive to dry for an hour before using.*

Rotate the grip for even application of the adhesive.

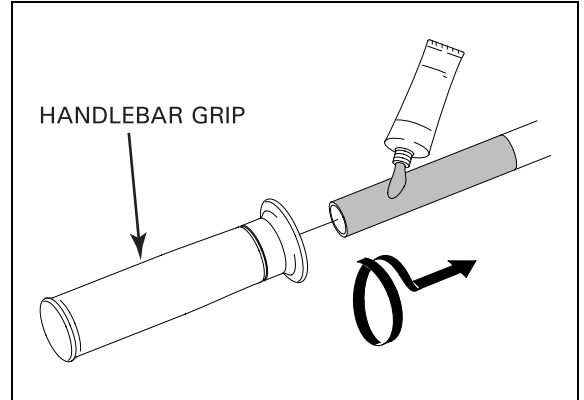

Install the left handlebar switch, aligning its locating pin with the hole in the left handlebar.

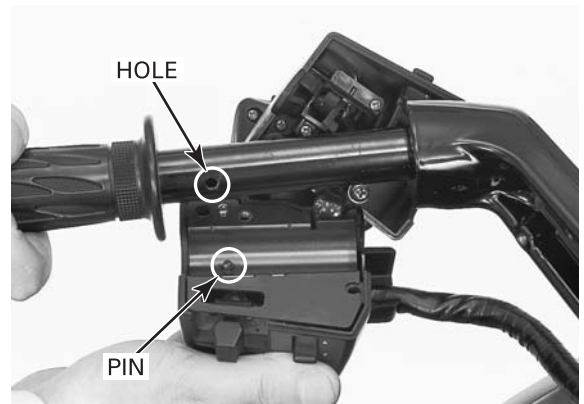

Install the setting plate and tighten the screw.

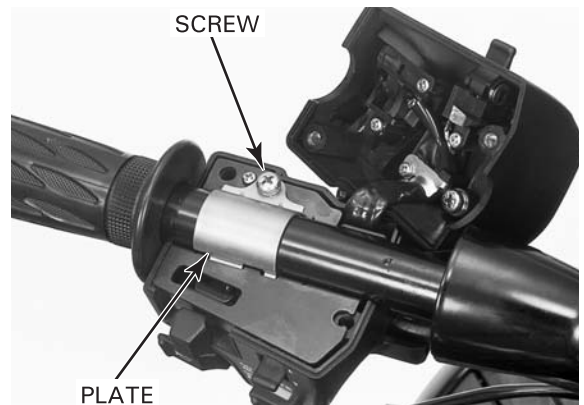

Install the left handlebar switch screws. Tighten the forward screw first, then the rear screw.

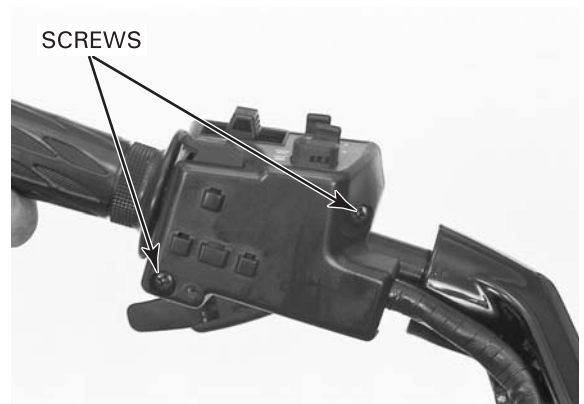

## FRONT WHEEL/SUSPENSION/STEERING

Route the wires and hose properly (page 1-23).

Install the handlebar setting plate and tighten the screws.

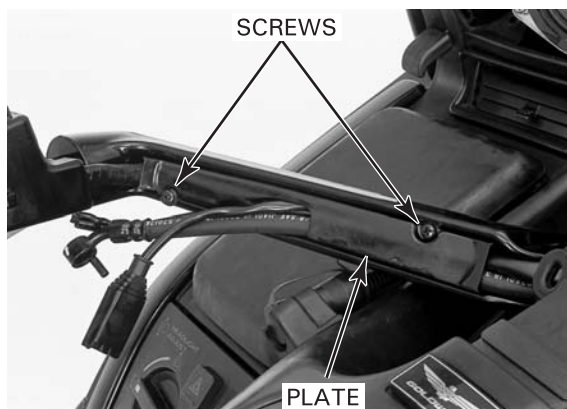

Place the left handlebar onto the top bridge and align the bolt holes securely, then install the handlebar mounting bolts and tighten them to the specified torque.

**TORQUE: 26 N·m (2.7 kgf·m, 20 lbf·ft)**

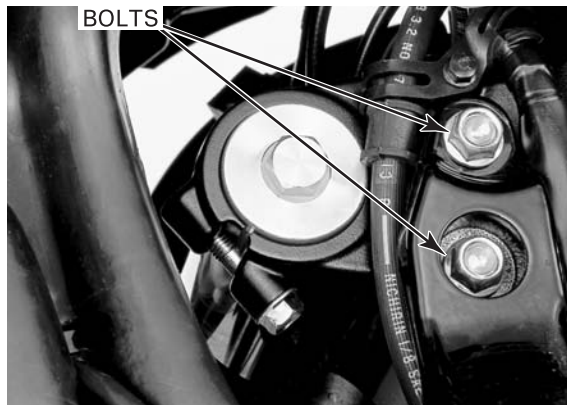

Install the clutch master cylinder and holder. Align the end of the master cylinder with the punch mark on the handlebar, and tighten the upper bolt first, then the lower bolt.

**TORQUE: 12 N·m (1.2 kgf·m, 9 lbf·ft)**

Connect the clutch switch connectors.  
Connect the clutch cruise switch connectors.

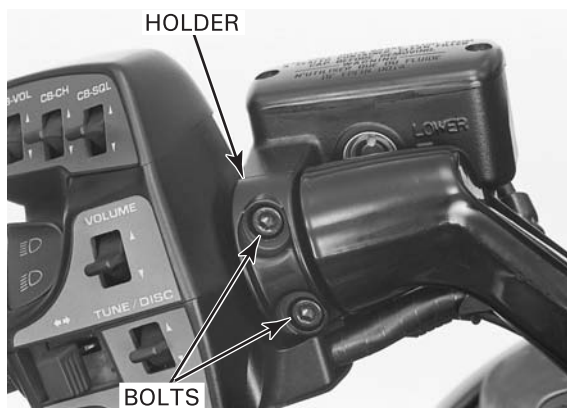

Install the holder cap onto the clutch master cylinder holder bolts.



Install the handlebar outer weight onto the inner weight, aligning the bosses and grooves. Install a new mounting screw and tighten it while holding the weight.

**TORQUE: 10 N·m (1.0 kgf·m, 7 lbf·ft)**

Install the handlebar center cover (page 13-7).  
Install the meter panel (page 2-7).

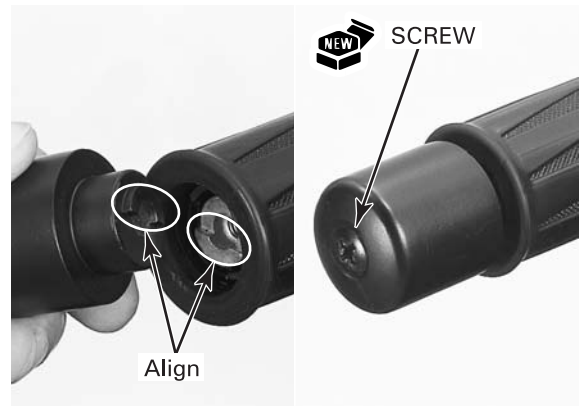

### RIGHT HANDLEBAR REMOVAL

Remove the meter panel (page 2-7).  
Remove the handlebar center cover (page 13-7).  
Hold the handlebar weight and remove the mounting screw and weight.

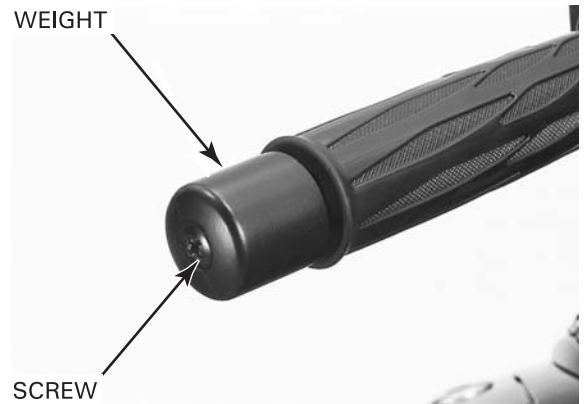

Remove the holder cap from the brake master cylinder holder bolts.



Disconnect the brake light/cruise cancel switch connectors.

Loosen the two brake master cylinder holder bolts, but do not remove them.





## FRONT WHEEL/SUSPENSION/STEERING

Release the throttle cables from the handlebar clamp.

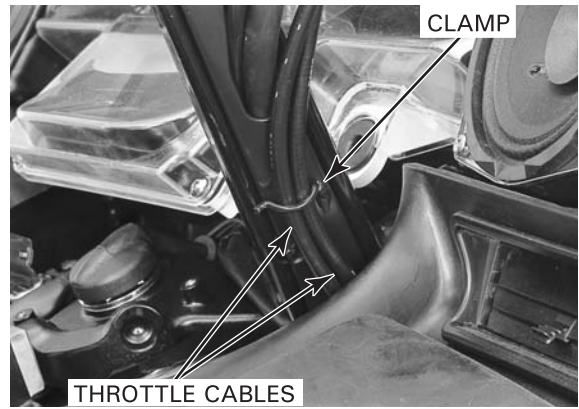

Remove the right handlebar mounting bolts.

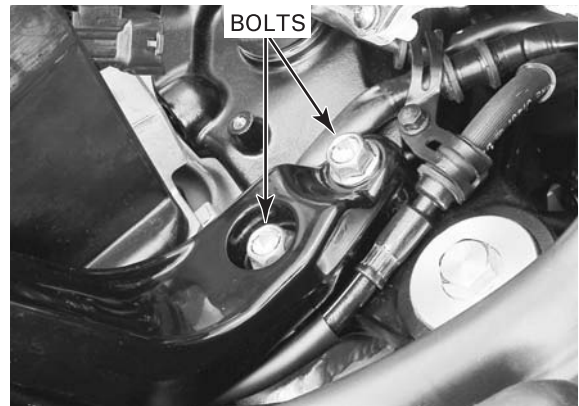

Remove the two screws and handlebar setting plate.

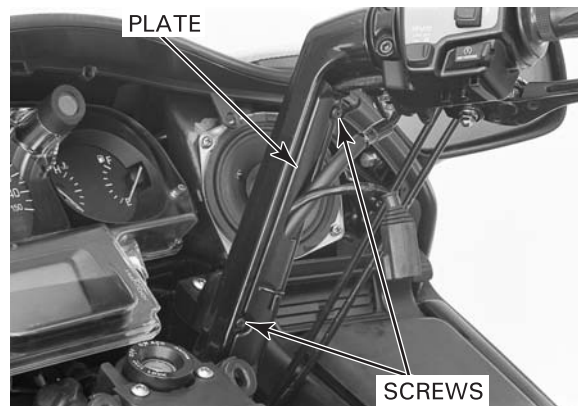

*Keep the brake reservoir upright to prevent air from entering the hydraulic system.*

Remove the two bolts, holder and the brake master cylinder assembly.

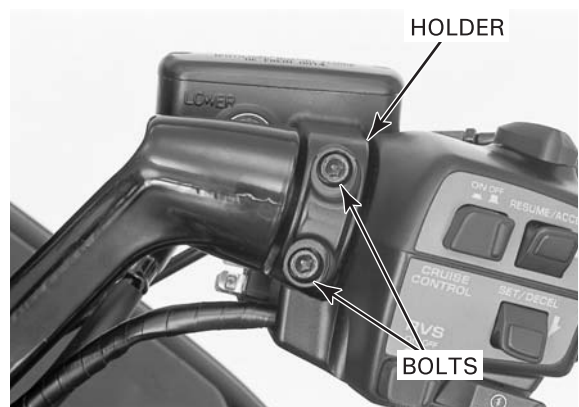



Remove the two screws from the right handlebar switch.

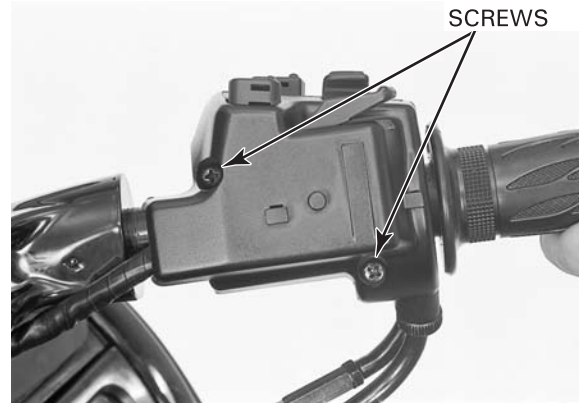

Remove the screw, and setting plate from the right handlebar switch.

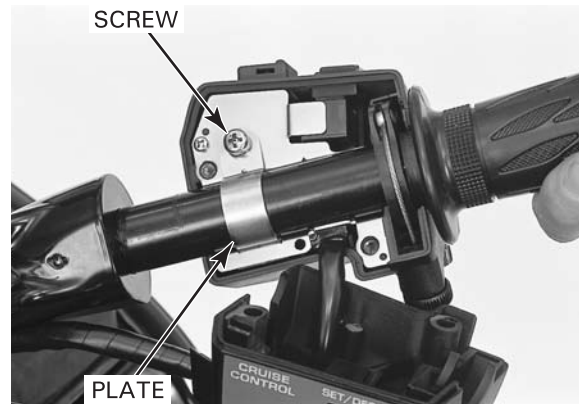

Remove the throttle grip from the right handlebar and disconnect the throttle cables from the throttle grip flange. Remove the throttle grip from the throttle pipe.

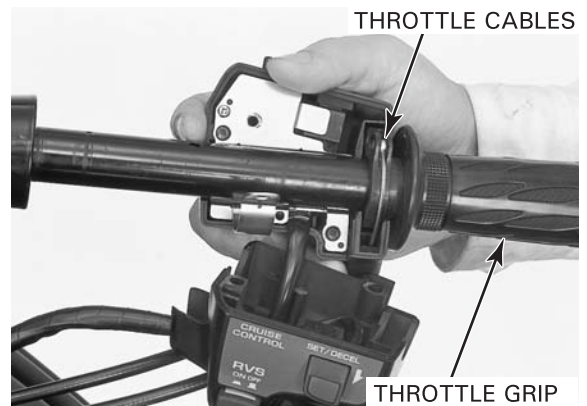

**RIGHT HANDLEBAR INSTALLATION**

Clean the inside surface of the throttle grip and the outside surface of the throttle pipe.

Apply Honda Bond A or equivalent to the inside surface of the throttle grip and to the outside surface of the throttle pipe.

Wait 3 - 5 minutes and install the grip.

Rotate the grip for even application of the adhesive.

*Allow the adhesive to dry for 1 hour before using.*

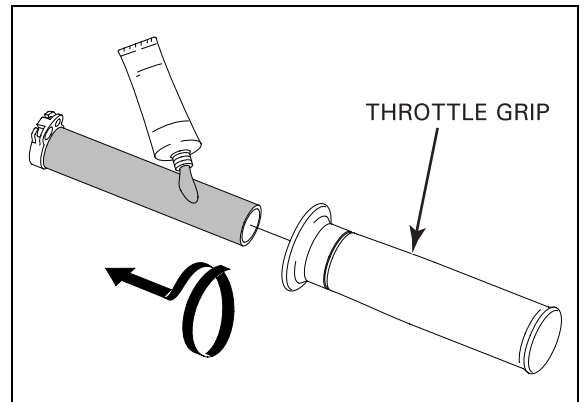

## FRONT WHEEL/SUSPENSION/STEERING

Apply grease to the throttle grip pipe flange and sliding surface.

*Route the cables properly (page 1-23).*

Connect the throttle cables to the throttle grip pipe flange and install the throttle grip onto the handlebar.

Install the right handlebar switch, aligning its locating pin with the hole in the right handlebar.

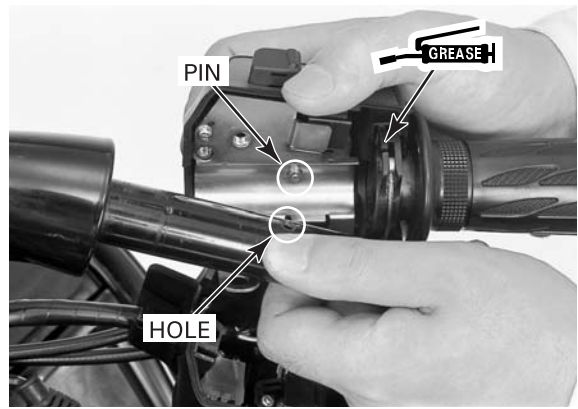

Install the setting plate and tighten the screw.

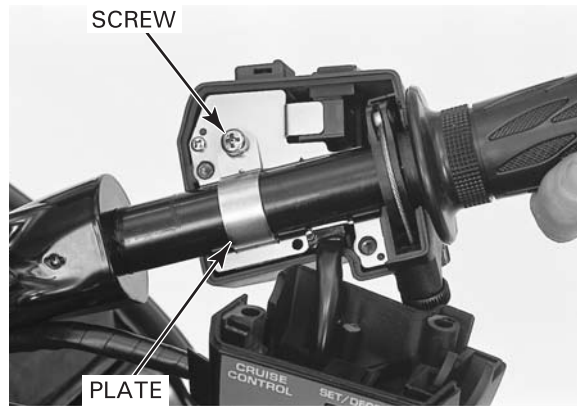

Install the right handlebar switch screws. Tighten the forward screw first, then the rear screw.

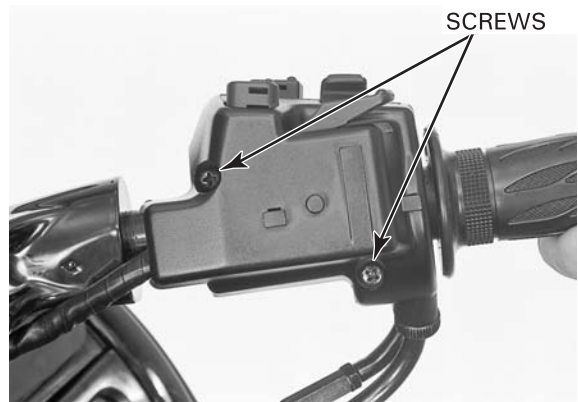

Install the brake master cylinder and holder. Align the end of the master cylinder with the punch mark on the handlebar and temporarily tighten the holder bolts.

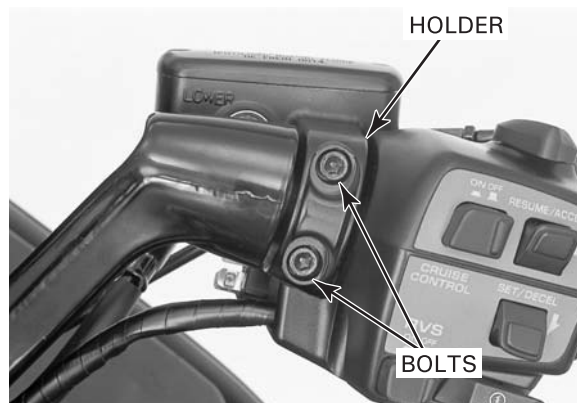

## FRONT WHEEL/SUSPENSION/STEERING

*Route the wires and hose properly (page 1-23).*

Install the handlebar setting plate and tighten the screws.

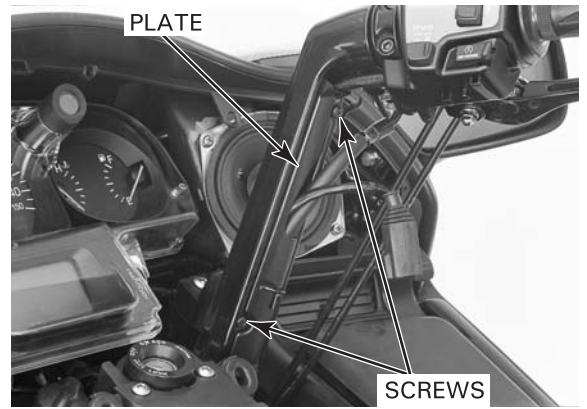

Place the right handlebar onto the top bridge and align the bolt holes securely. Then install the handlebar mounting bolts and tighten them to the specified torque.

**TORQUE: 26 N·m (2.7 kgf·m, 20 lbf·ft)**

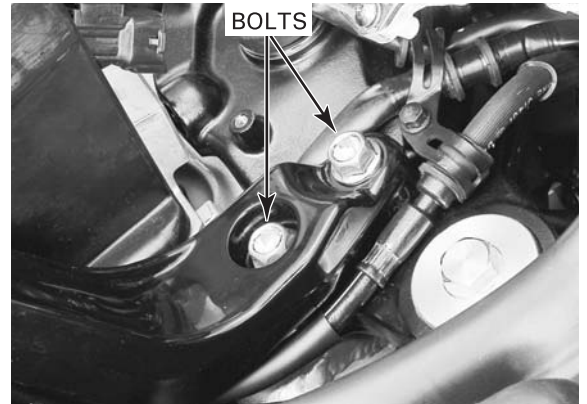

Securely clamp the throttle cables with the handlebar clamp.

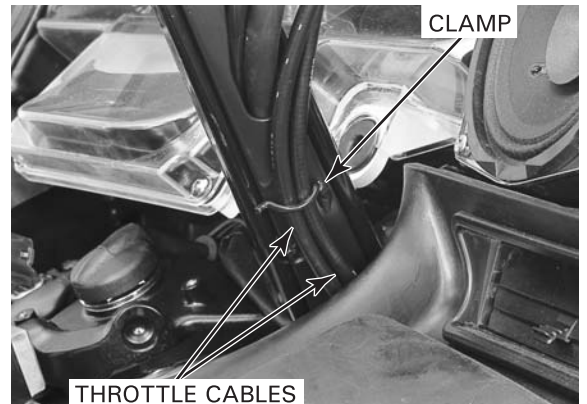

Make sure the end of the master cylinder aligns with the handlebar, and tighten the upper bolt first, then the lower bolt.

**TORQUE: 12 N·m (1.2 kgf·m, 9 lbf·ft)**

Connect the brake light/cruise cancel switch connectors.



## FRONT WHEEL/SUSPENSION/STEERING

Install the holder cap onto the brake master cylinder holder bolts.



Install the handlebar outer weight onto the inner weight, aligning the bosses and grooves. Install a new mounting screw and tighten it while holding the weight.

**TORQUE: 10 N·m (1.0 kgf·m, 7 lbf·ft)**

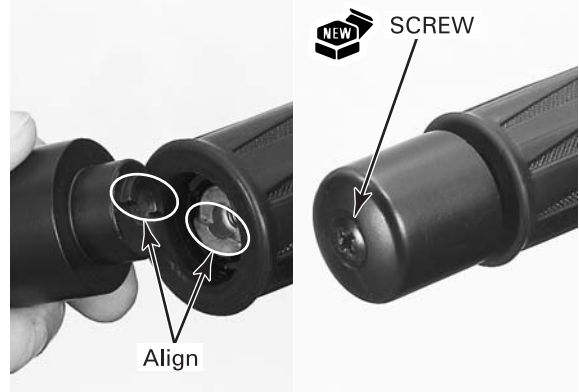

Install and secure the handlebar center cover with the two screws.

Install the meter panel (page 2-7).

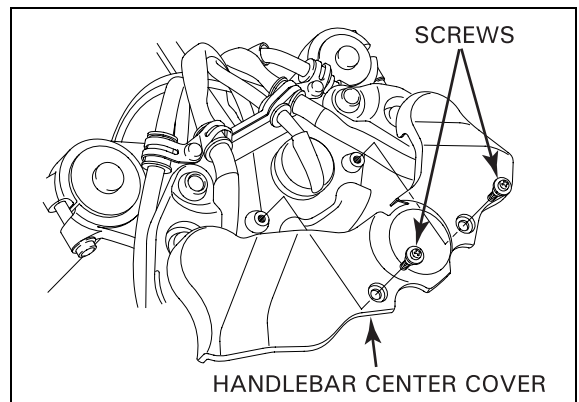

## FRONT WHEEL

### REMOVAL

*Be careful not to damage the wheel speed sensor and pulse ring.*

Remove the front fender covers and front fender A (page 2-6).

Support the motorcycle securely using a hoist or equivalent and raise the front wheel off the ground.

#### NOTE:

- Do not operate the brake lever and pedal after removing the brake caliper.

Cover both sides of the front wheel with protective tape or an equivalent to prevent damaging it.

*Support the brake caliper so that it does not hang from the brake hoses. Do not twist the brake hoses.*

Remove the two mounting bolts (lower pivot and upper joint bolts) and left front brake caliper. Remove the pivot collars from the fork and caliper bracket.

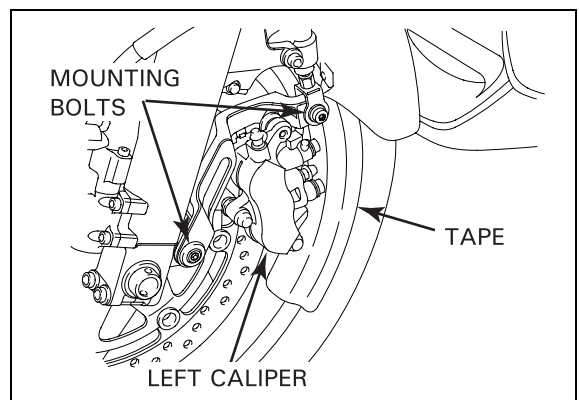



## FRONT WHEEL/SUSPENSION/STEERING

Remove the clamp bolt and speed sensor wire clamp.

*Support the brake caliper so that it does not hang from the brake hoses. Do not twist the brake hoses.*

Remove the two brake caliper mounting bolts and right front brake caliper.

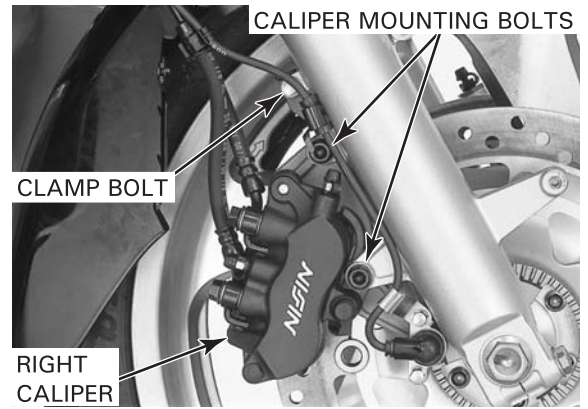

Loosen the right axle holder bolts.  
Remove the front axle bolt.

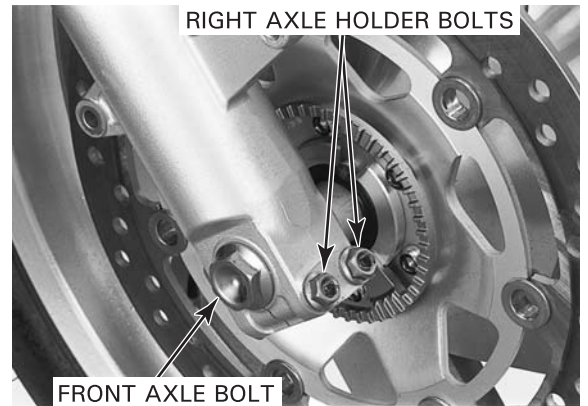

Loosen the left front axle holder bolts.  
Remove the front axle and the front wheel.

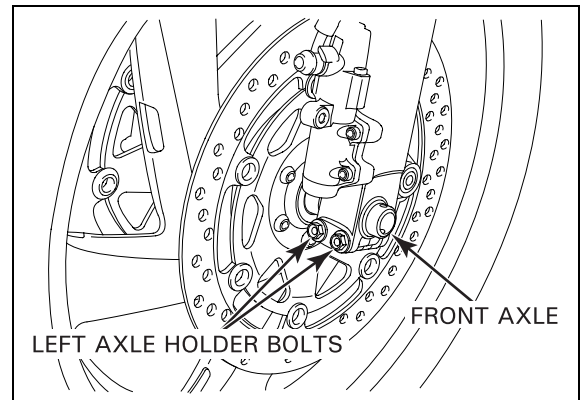

Remove the side collars.

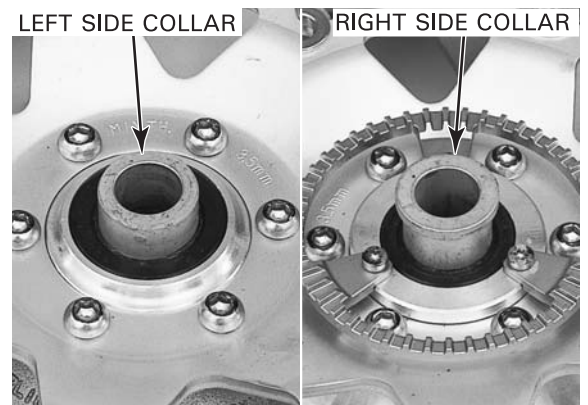

## FRONT WHEEL/SUSPENSION/STEERING

### INSPECTION

#### AXLE

Set the front axle in V-blocks.  
Turn the front axle and measure the runout using a dial indicator.  
Actual runout is 1/2 the total indicator reading.

**SERVICE LIMIT: 0.20 mm (0.008 in)**

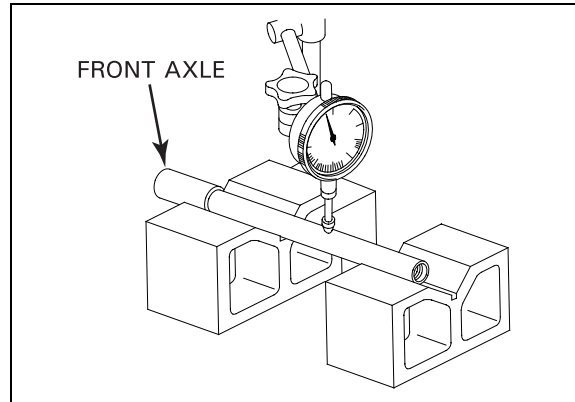

#### WHEEL RIM

Check the rim runout by placing the wheel in a truing stand.  
Spin the wheel slowly and read the runout using a dial indicator.  
Actual runout is 1/2 the total indicator reading.

**SERVICE LIMITS: Radial: 2.0 mm (0.08 in)  
Axial: 2.0 mm (0.08 in)**

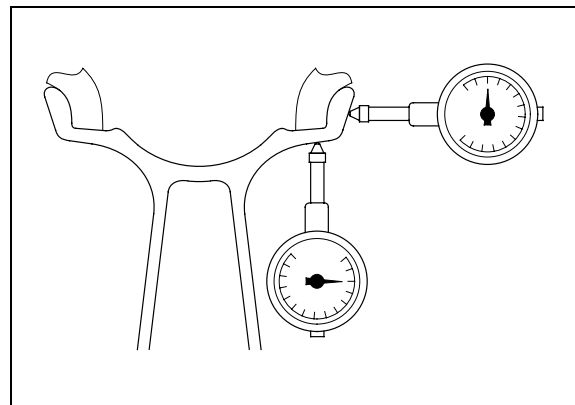

#### WHEEL BEARING

*Replace the wheel bearings in pairs.*

Turn the inner race of each bearing with your finger; the bearings should turn smoothly and quietly. Also check that the bearing outer race fits tightly in the hub.

Remove and discard the bearings if the races do not turn smoothly and quietly, or if they fit loosely in the hub.

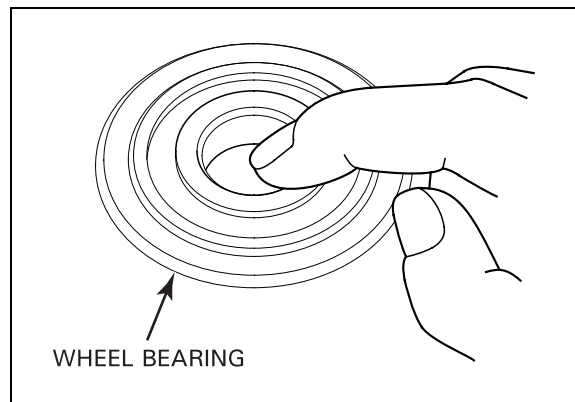

### DISASSEMBLY

Remove the dust seals.

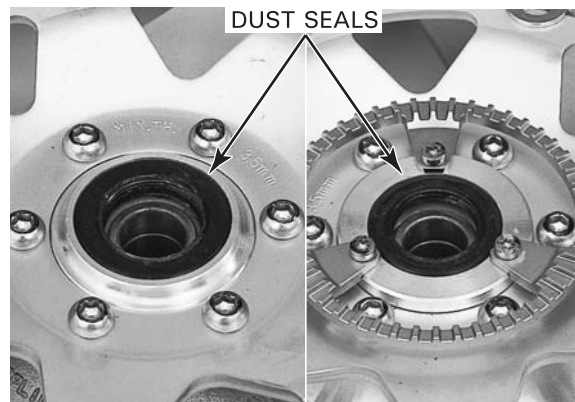



## FRONT WHEEL/SUSPENSION/STEERING

Remove the three bolts and front pulser ring from the right wheel hub.

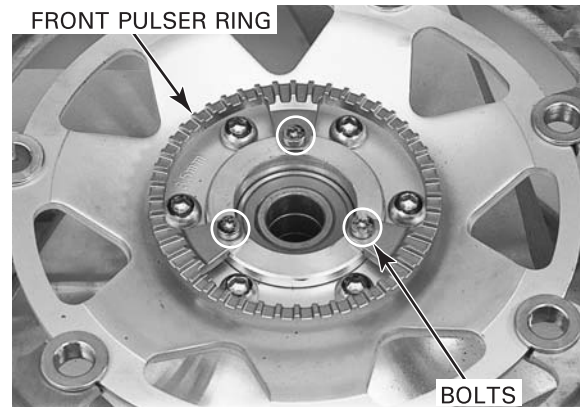

Remove the six brake disc bolts and brake disc from the right wheel hub.

Remove the six brake disc bolts and brake disc from the left wheel hub.

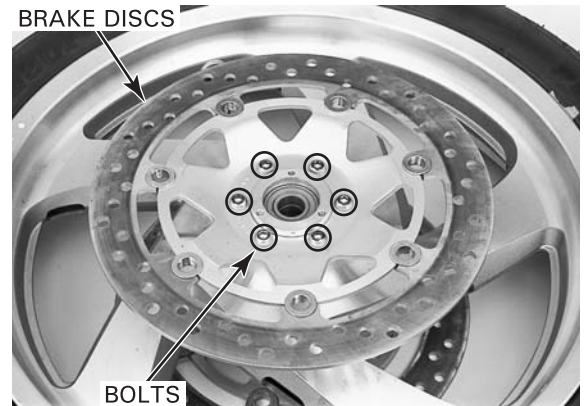

*Replace the wheel bearings in pairs. Do not reuse old bearings.*

Install the bearing remover head into the bearing. From the opposite side of the wheel, install the bearing remover shaft and drive the bearing out of the wheel hub. Remove the distance collar and drive out the other bearing.

### TOOLS:

**Bearing remover shaft** 07746-0050100  
**Bearing remover head, 20 mm** 07746-0050600

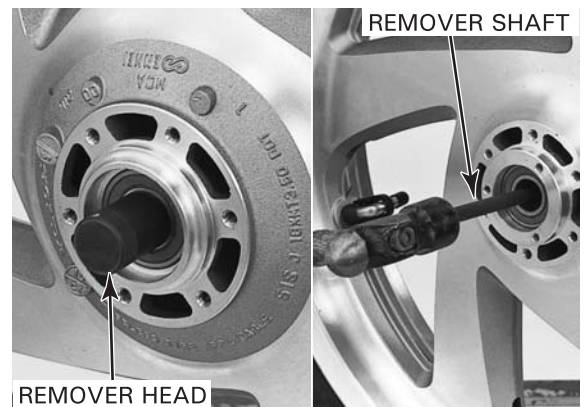

# FRONT WHEEL/SUSPENSION/STEERING

## ASSEMBLY

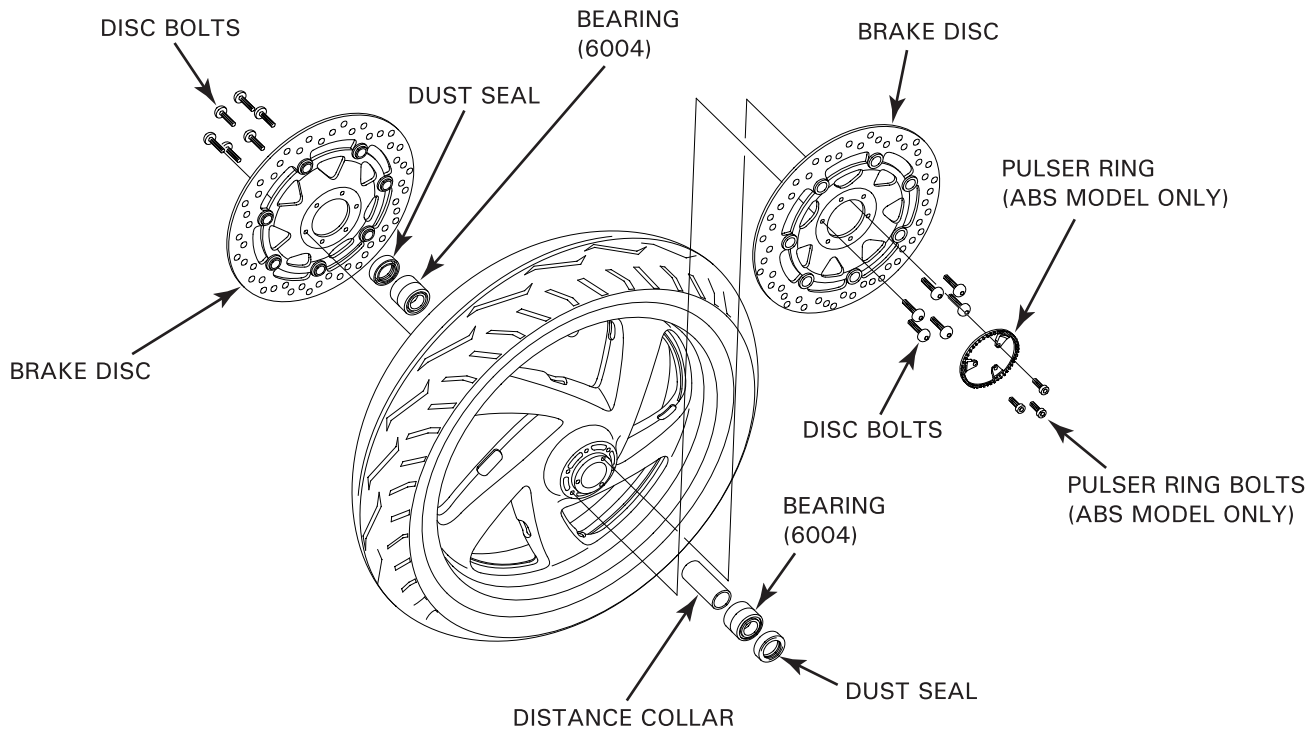

Drive in a new right bearing squarely with the marked side facing up until it is fully seated.  
Install the distance collar.  
Drive in a new left bearing squarely with the marked side facing up until it is fully seated.

### TOOLS:

<b>Driver</b>	<b>07749-0010000</b>
<b>Attachment, 42 x 47 mm</b>	<b>07746-0010300</b>
<b>Pilot, 20 mm</b>	<b>07746-0040500</b>

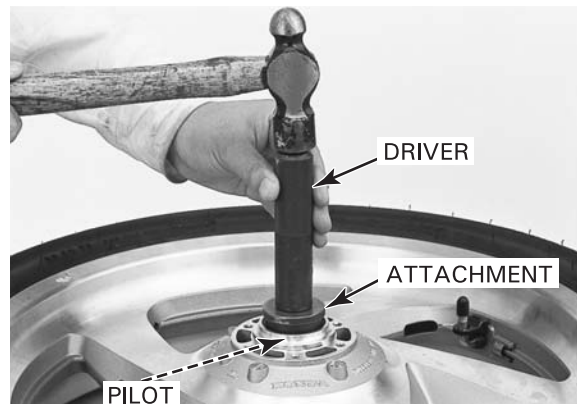

Install the brake discs with the arrow mark facing out.  
Install new disc bolts and tighten them in a criss-cross pattern in two or three steps.

**TORQUE: 20 N·m (2.0 kgf·m, 14 lbf·ft)**



Install the pulser ring onto the right wheel hub.  
Install new pulser ring bolts and tighten them in a crisscross pattern in two or three steps.

**TORQUE: 8 N·m (0.8 kgf·m, 5.8 lbf·ft)**

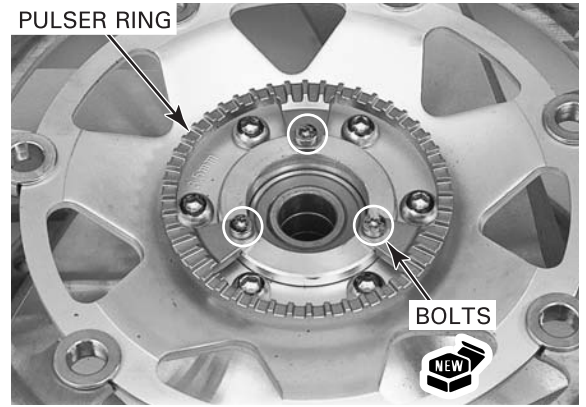

### WHEEL BALANCE

#### NOTE:

*Wheel balance directly affects the stability, handling and overall safety of the motorcycle. Carefully check balance before re-installing the wheel.*

- Mount the tire with the arrow mark facing in the direction of rotation.
- The wheel balance must be checked when the tire is remounted.
- For optimum balance, the tire balance mark (a paint dot on the side wall) must be located next to the valve stem. Remount the tire if necessary.

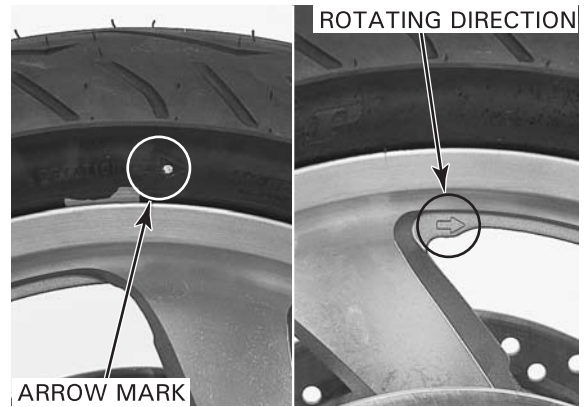

Mount the wheel, tire and brake discs and pulser ring (ABS model only) assembly on an inspection stand.

Spin the wheel, allow it to stop, and mark the lowest (heaviest) part of the wheel with chalk.

Do this two or three times to verify the heaviest area.

If the wheel is balanced, it will not stop consistently in the same position.

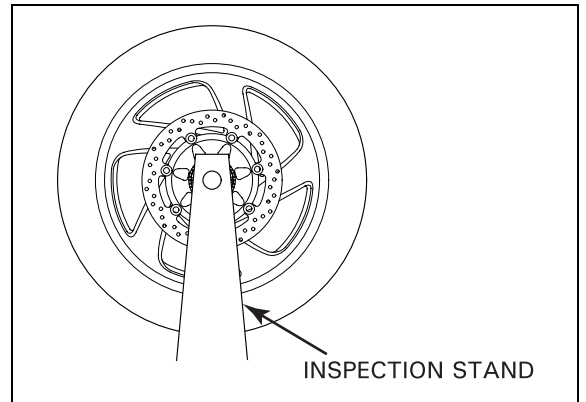

To balance the wheel, install a balance weight on the lightest side of the spoke, on the side opposite the chalk marks. Add just enough weight so the wheel will no longer stop in the same position when it is spun.

Do not add more than 60 g (2.1 oz) to the front wheel.

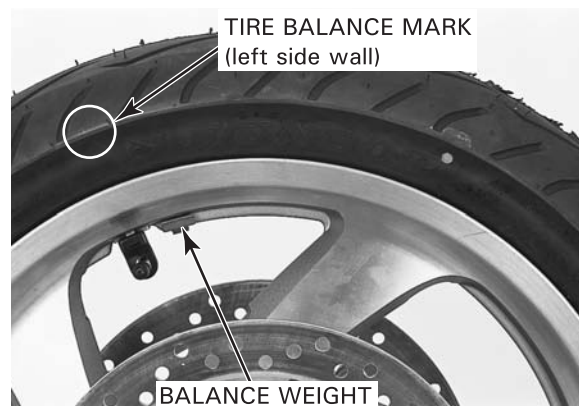

## FRONT WHEEL/SUSPENSION/STEERING

*Do not get grease on the brake discs or stopping power will be reduced.*

Apply grease to new dust seal lips and install the dust seals until they are flush with the wheel hub.

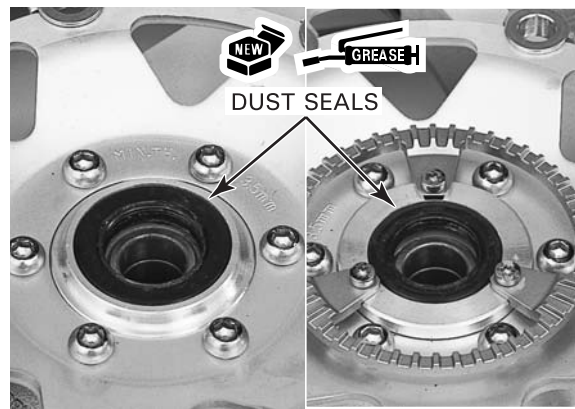

### INSTALLATION

Install the side collars.

*Be careful not to damage the wheel speed sensor and pulser ring.*

#### NOTE:

- The right side collar is longer than the left side collar.

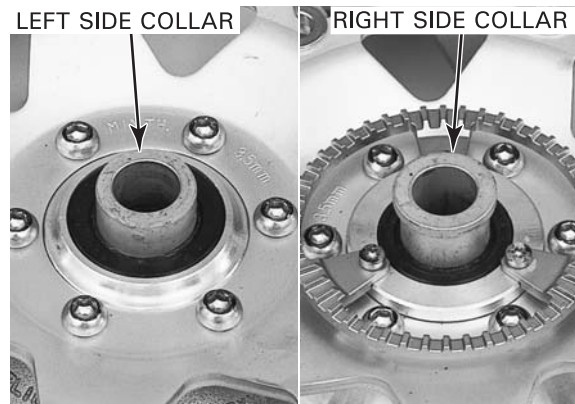

Place the front wheel between the fork legs. Insert the front axle from the left side until it is fully seated.

Make sure the index line on the axle is aligned with the fork leg.

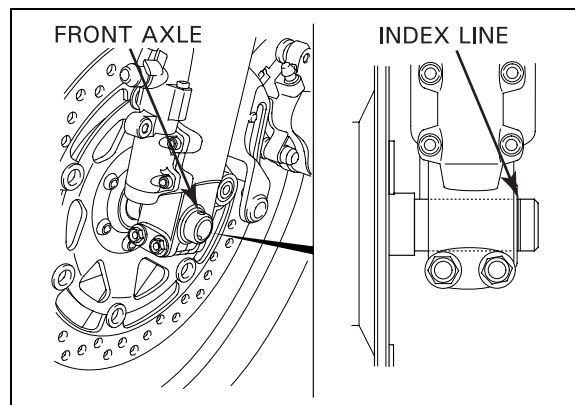

Install the axle bolt and tighten it to the specified torque while holding the axle.

**TORQUE: 59 N·m (6.0 kgf·m, 43 lbf·ft)**

Tighten the right axle holder bolts to the specified torque.

**TORQUE: 22 N·m (2.2 kgf·m, 16 lbf·ft)**

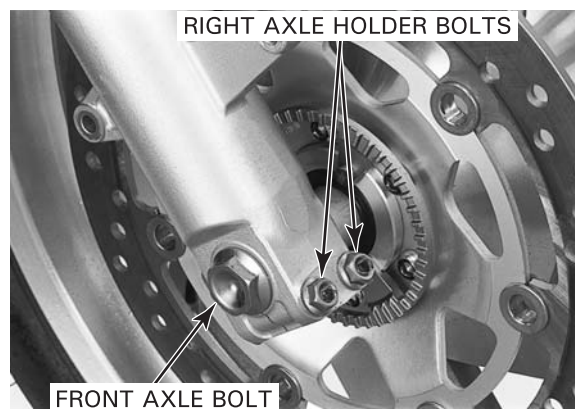



## FRONT WHEEL/SUSPENSION/STEERING

Install the right front brake caliper with new mounting bolts so the disc is positioned between the pads, being careful not to damage the pads. Tighten the mounting bolts.

**TORQUE: 31 N·m (3.2 kgf·m, 23 lbf·ft)**

Install the speed sensor wire clamp and tighten the bolt.

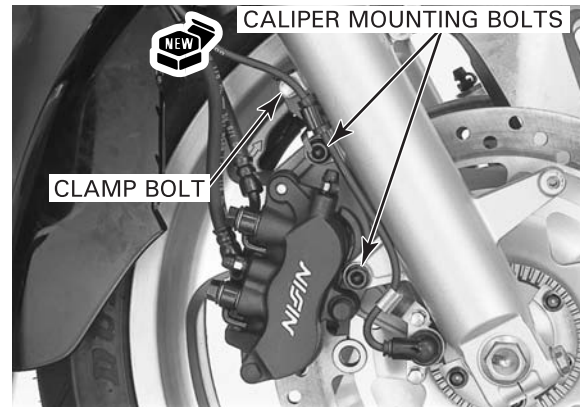

Apply grease to the lower pivot bearing and dust seal lips, and to the outer surface of the upper pivot collar.

Install the pivot collars into the fork and caliper bracket.

Install the left front brake caliper with new mounting bolts (lower pivot and upper joint bolts) and tighten them.

**TORQUE: Pivot bolt: 31 N·m (3.2 kgf·m, 23 lbf·ft)**  
**Joint bolt: 25 N·m (2.6 kgf·m, 19 lbf·ft)**

Remove the protective tape.

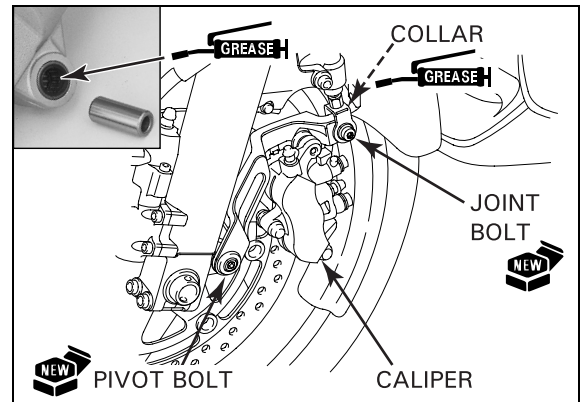

With the front brake applied, pump the forks up and down several times to seat the axle and check brake operation.



Tighten the left axle holder bolts to the specified torque.

**TORQUE: 22 N·m (2.2 kgf·m, 16 lbf·ft)**

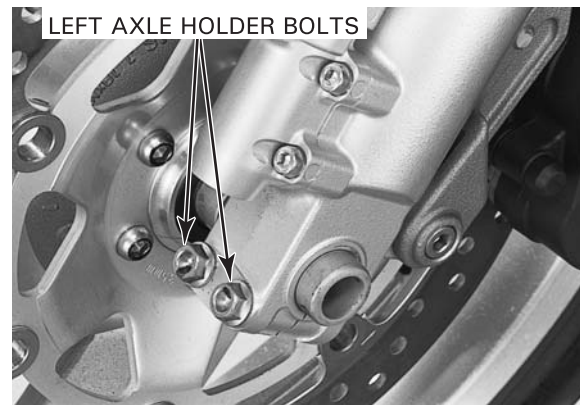

## FRONT WHEEL/SUSPENSION/STEERING

Check the clearance between the brake disc and caliper bracket on each side after installation. The clearance should be at least 0.7 mm (0.28 in).

If the feeler gauge cannot be inserted easily, loosen the axle holder bolts and pull the fork outward or push inward to adjust the clearance. Then tighten the axle holder bolts to the specified torque.

### NOTICE

*After installing the wheel, apply the front and rear brakes several times and recheck the caliper clearances between each surface of the brake disc and the brake caliper. Failure to provide clearance will damage the brake disc and affect braking efficiency.*

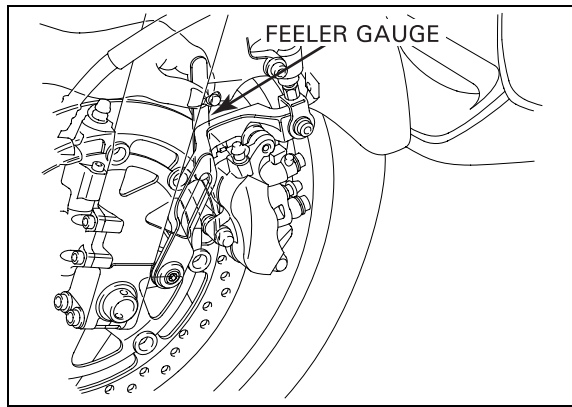

*ABS model only.* Check the front wheel speed sensor air gap (page 16-29).

Install front fender A (page 2-6).

Install the front fender side covers (page 2-6).

## FORK

### REMOVAL

Remove the front wheel (page 13-16).

Remove the following:

- trim clip
- two bolts
- front fender top cover

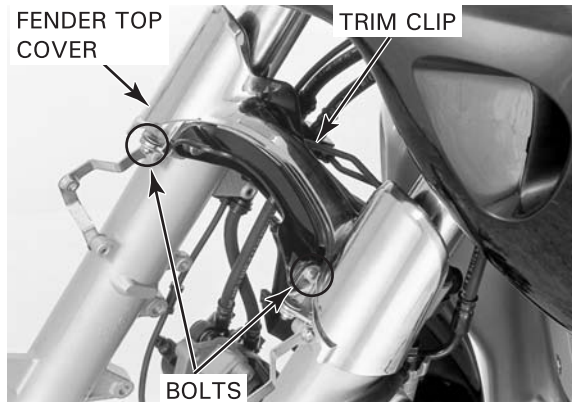

- two front fender B mounting bolts from the left fork leg

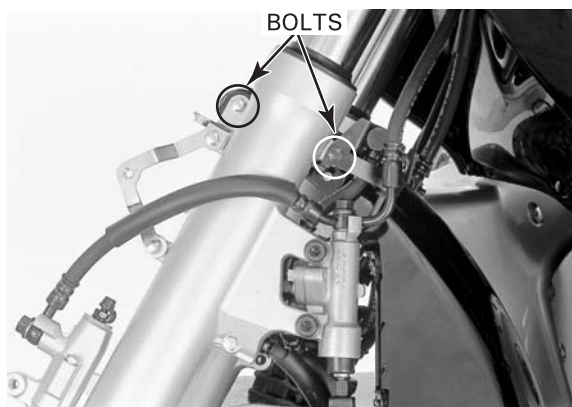



## FRONT WHEEL/SUSPENSION/STEERING

- two front fender B mounting bolts from the right fork leg
- front fender B
- delay valve mounting bolt

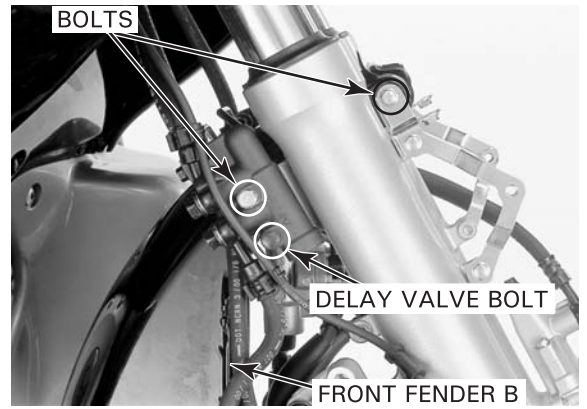

- two bolts and anti-dive plunger case
  - oil hose joint attaching bolt
  - two secondary master cylinder mounting bolts
- Do not hang the brake caliper and secondary master cylinder from the brake hoses.

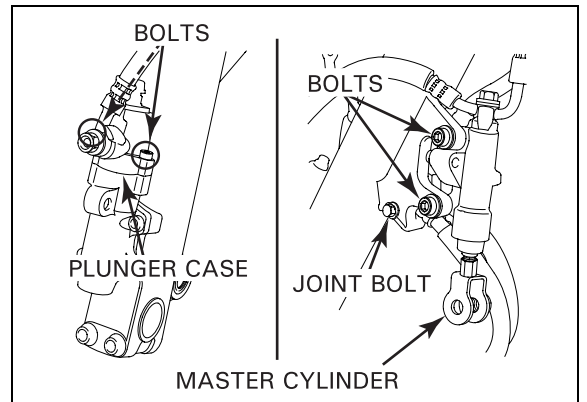

*The fork cap is under spring pressure; use care when loosening it.*

Loosen the fork top bridge pinch bolts. When the fork is ready to be disassembled, loosen the fork caps, but do not remove them.

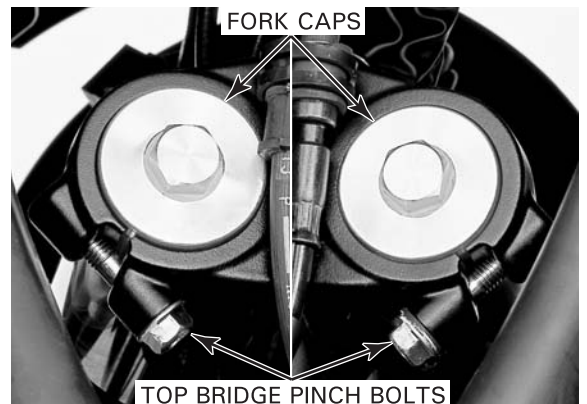

*Be careful not to drop the fork legs when loosening the bolts.*

Loosen the bottom bridge pinch bolts and remove the fork tubes from the fork bridges.

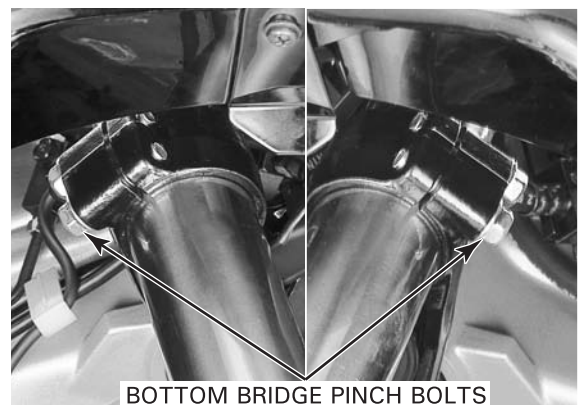

## FRONT WHEEL/SUSPENSION/STEERING

### LEFT FORK LEG DISASSEMBLY

Remove the two bolts and front fender mounting plate.  
Remove the axle holder bolts.

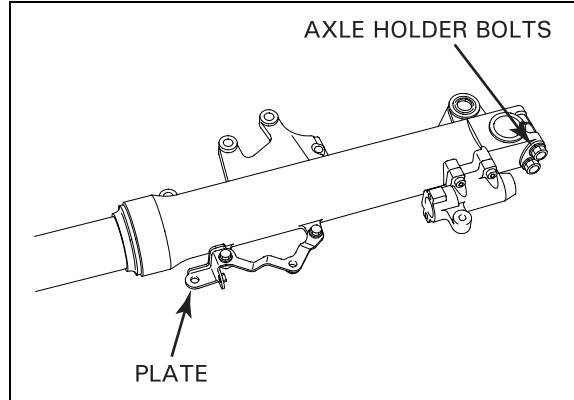

Remove the joint collar.

Check the dust seals for wear, damage or fatigue.  
Check the needle bearings for damage or loose fit.

If the needle bearings are damaged, replace them (page 13-32).

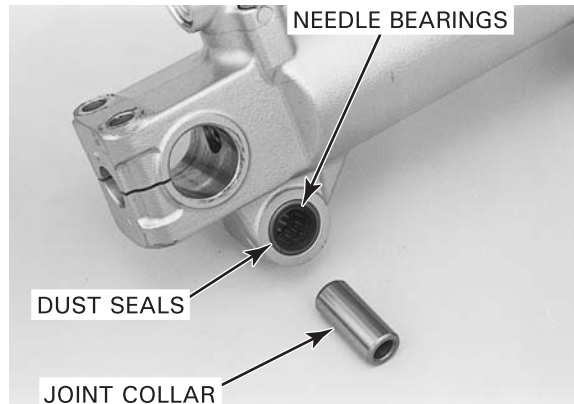

*The fork cap is under spring pressure; use care when removing it.*

Remove the fork cap from the fork tube.  
Remove the O-ring from the fork cap.



Remove the following:

- spacer
- spring seat
- fork spring

Pour out the fork fluid by pumping the fork tube up and down several times.

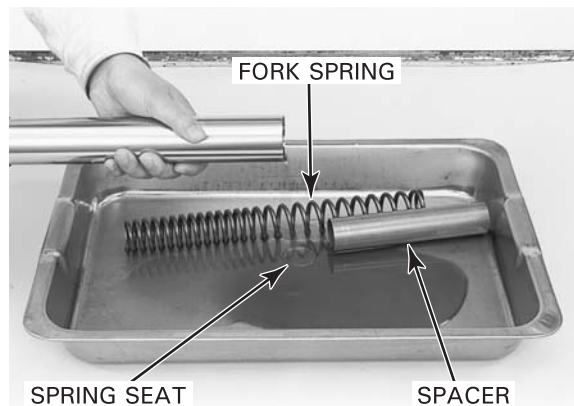

## FRONT WHEEL/SUSPENSION/STEERING

*If the fork piston turns with the center bolt, temporarily install the fork spring, spring seat, spacer and fork cap.*

Hold the fork slider in a vise with soft jaws or shop towel and remove the center bolt and sealing washer.

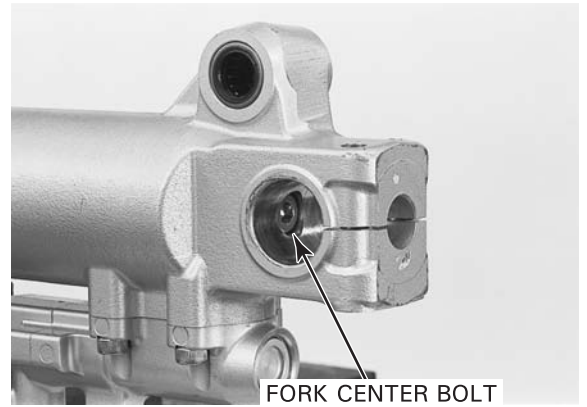

Remove the dust seal.  
Remove the stopper ring being careful not to scratch the fork tube sliding surface.

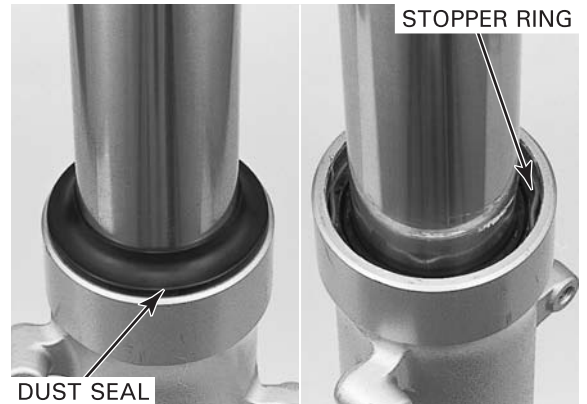

Using quick successive motions, pull the fork tube out of the fork slider.

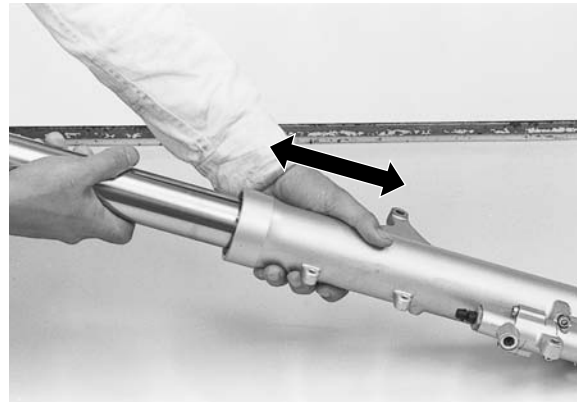

Remove the following:

- stopper ring
- oil lock valve
- oil lock spring
- spring seat
- stopper ring

Remove the fork piston and rebound spring from the fork tube.

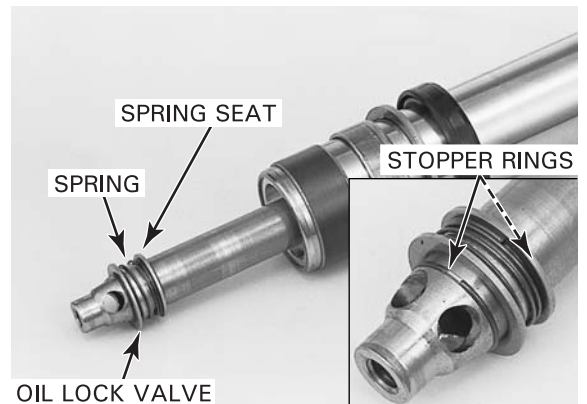

## FRONT WHEEL/SUSPENSION/STEERING

Remove the oil seal, back-up ring and guide bushing from the fork tube.

*Do not remove the slider bushing unless it is necessary to replace it with a new one.*

Carefully remove the slider bushing by prying the slot with a screwdriver until the bushing can be pulled off by hand.

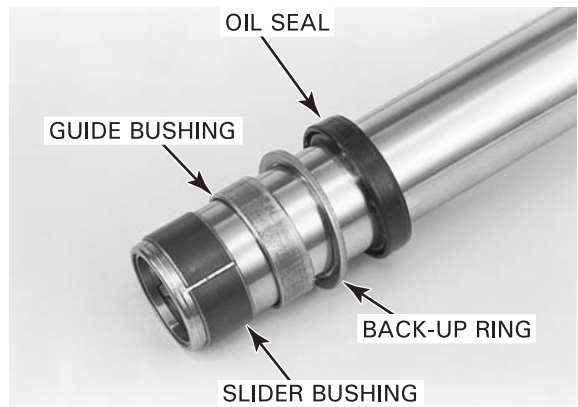

### LEFT FORK LEG INSPECTION

#### FORK SPRING

Measure the fork spring free length.

**SERVICE LIMIT: 328.6 mm (12.94 in)**

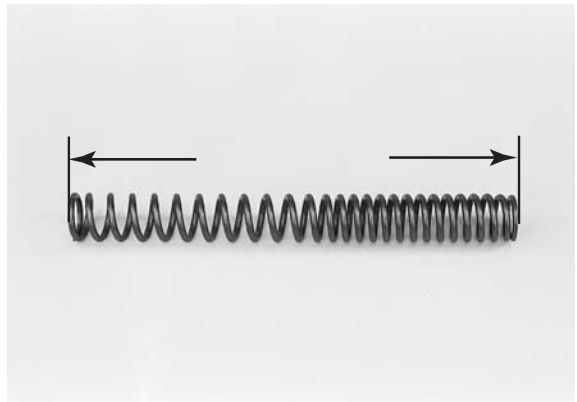

#### FORK TUBE/SLIDER/PISTON

Check the fork tube, slider and fork piston for score marks, and excessive or abnormal wear.

Check the rebound spring for fatigue or damage.

Check the fork piston ring for wear or damage.

Replace any damaged component if necessary.

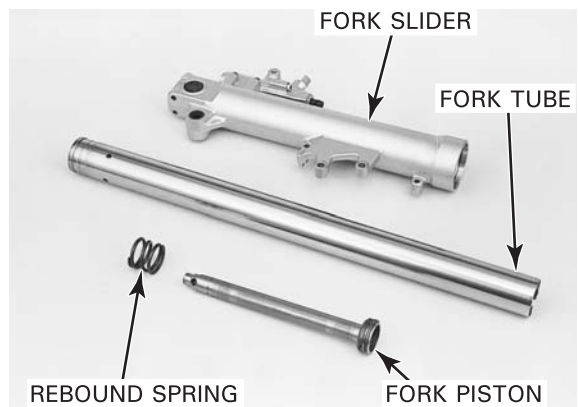

Set the fork tube in V-blocks and measure the fork tube runout with a dial indicator.

Actual runout is 1/2 the total indicator reading.

**SERVICE LIMIT: 0.20 mm (0.008 in)**

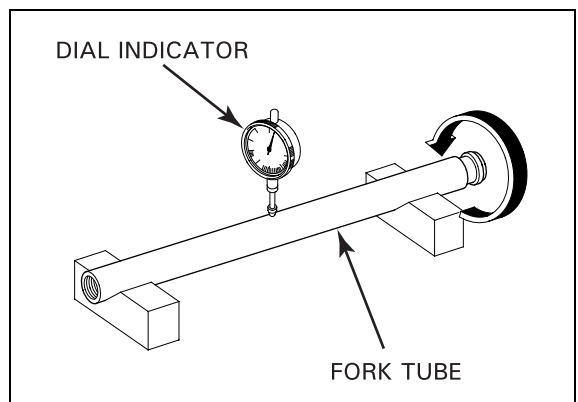

Visually inspect the slider and guide bushings. Replace the bushings if there is excessive scoring or scratching, or if the teflon is worn so that the copper surface appears on more than 3/4 of the entire surface.

Check the back-up ring; replace it if there is any distortion at the points shown.

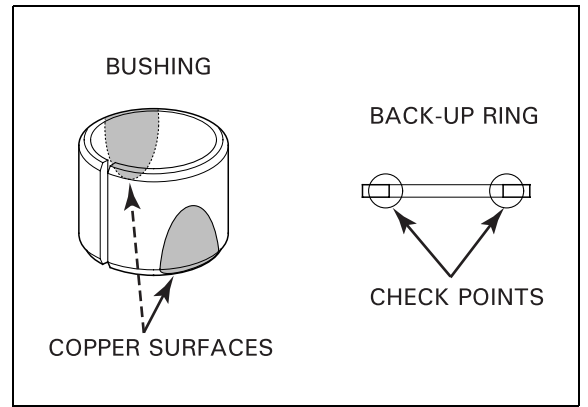

**LEFT FORK LEG ASSEMBLY**

Before assembly, wash all parts with a high flash point or non-flammable solvent and wipe them off completely.

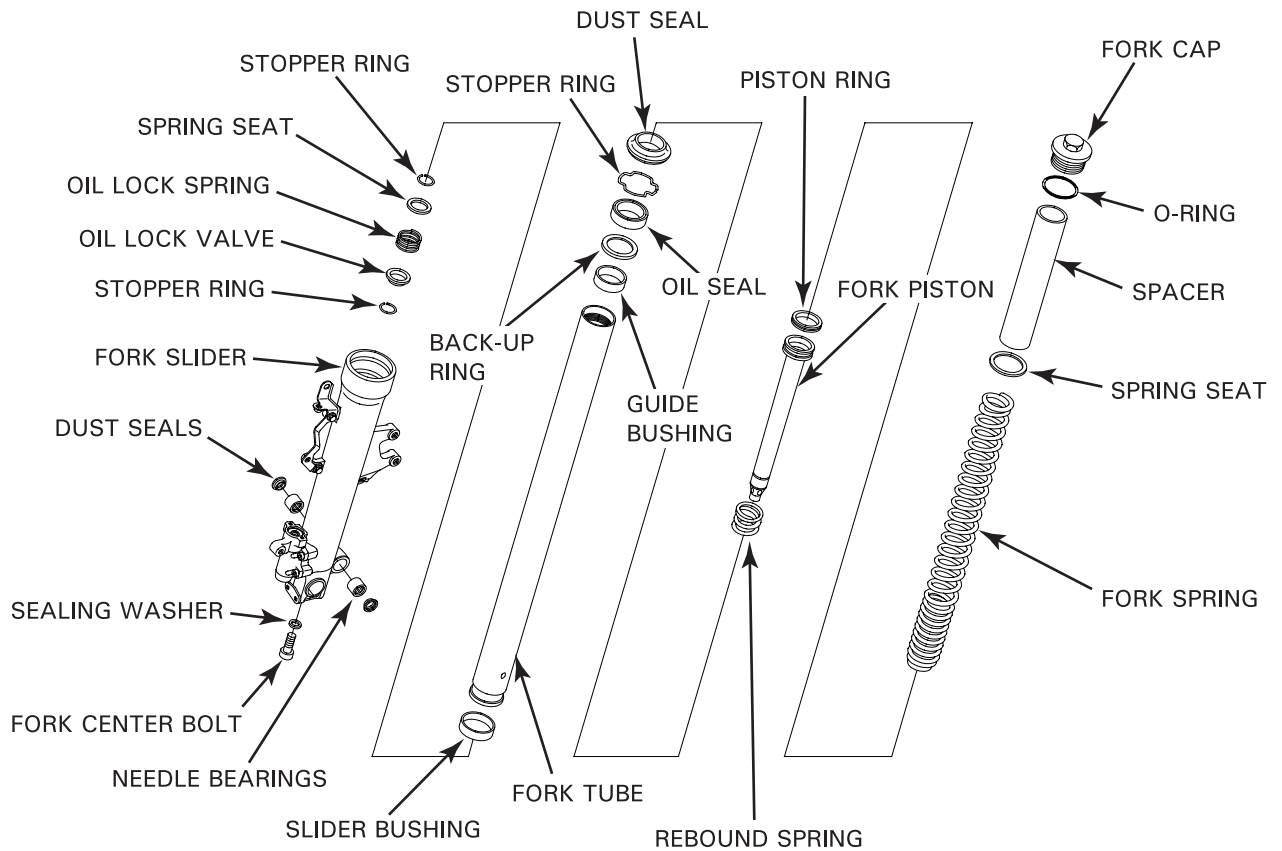

## FRONT WHEEL/SUSPENSION/STEERING

*Be careful not to damage the coating of the bushing. Do not spread open the bushing more than necessary.*

Install a new slider bushing if the bushing has been removed.

**NOTE:**

- Remove the burrs from the bushing mating surface, being careful not to peel off the coating.

Install the guide bushing and install the back-up ring with its chamfered surface side facing down.

Apply fork fluid to a new oil seal lip.

Install the oil seal with the marks side facing up.

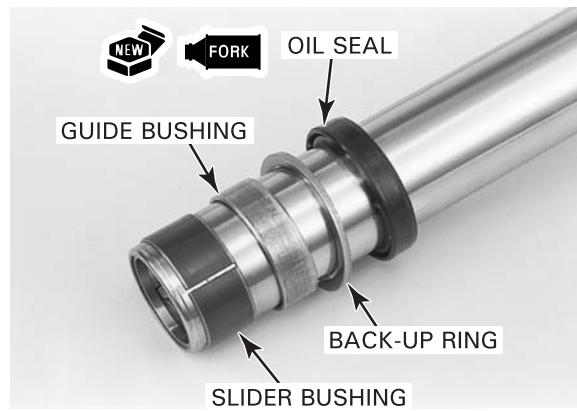

Install the rebound spring onto the fork piston. Install the fork piston into the fork tube.

Install the following:

- stopper ring
- spring seat
- oil lock spring
- oil lock valve
- stopper ring

Install the fork tube into the fork slider.

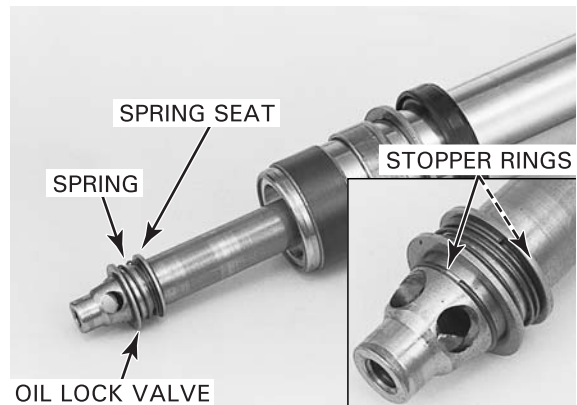

*If the fork piston turns with the center bolt, temporarily install the fork spring, spring seat, spacer and fork cap.*

Hold the fork slider in a vise with soft jaws or a shop towel.

Apply locking agent to the center bolt threads.

Install the center bolt with a new sealing washer and tighten it to the specified torque.

**TORQUE: 20 N·m (2.0 kgf·m, 14 lbf·ft)**

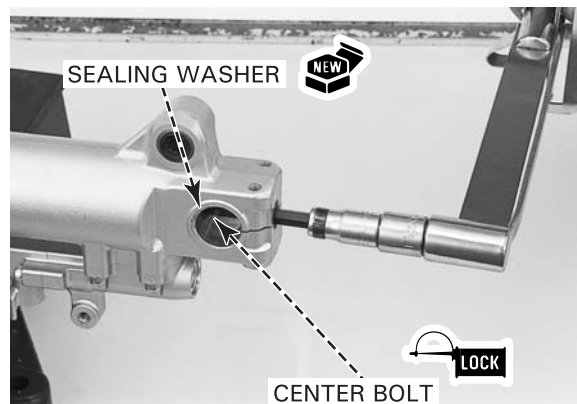

Drive the oil seal into the fork slider until the stopper ring groove is visible using the special tool.

**TOOL:**

**Fork seal driver, 45 mm**

**07KMD-KZ30100 or  
07KMD-KZ3010A  
(U.S.A. only)**





Install the stopper ring into the groove into the fork slider being careful not to scratch the fork tube sliding surface.  
Apply fork fluid to the lip of a new dust seal and install the dust seal.

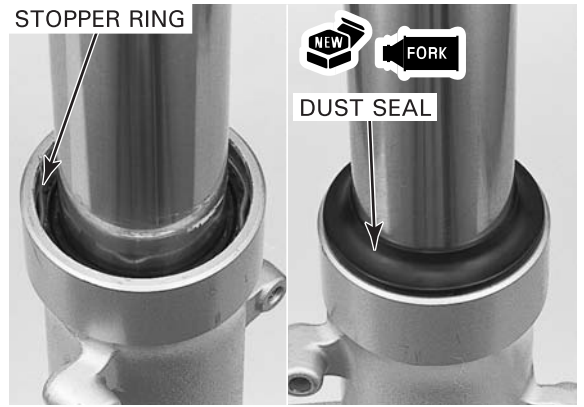

Pour the specified amount of the recommended fork fluid into the fork tube.

**RECOMMENDED FORK FLUID:**  
**Pro Honda Suspension Fluid SS-8**

**FORK FLUID CAPACITY:**  
**529 ± 2.5 cm<sup>3</sup> (17.9 ± 0.08 US oz,**  
**18.6 ± 0.09 Imp oz)**

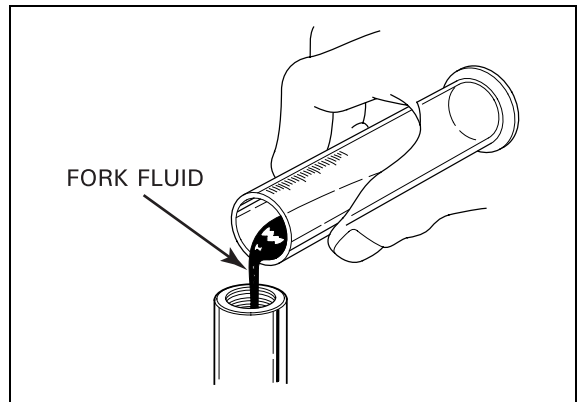

Slowly pump the fork tube several times to remove any trapped air from the lower portion of the fork tube.

Compress the fork tube fully.  
Measure the oil level from the top of the fork tube.

**FORK FLUID LEVEL: 128 mm (5.0 in)**

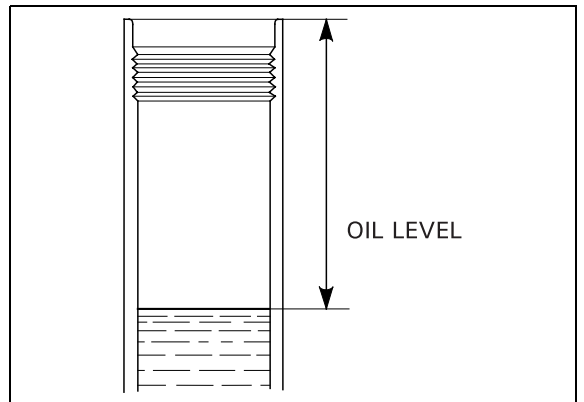

Pull the fork tube up and install the fork spring with the tightly wound coil side facing down.

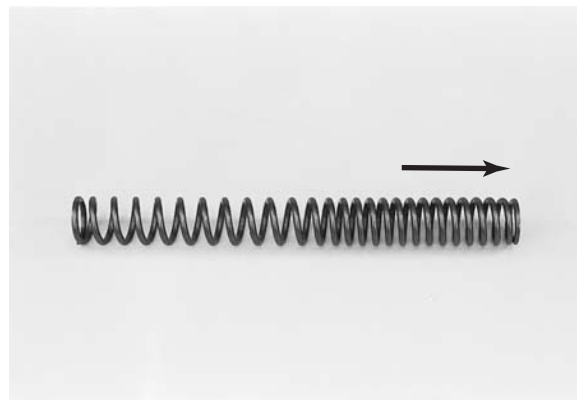

## FRONT WHEEL/SUSPENSION/STEERING

Install the spring seat and spacer.

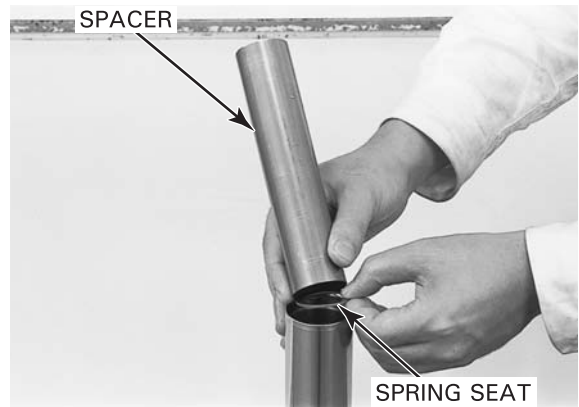

*Tighten the fork cap after installing the fork tube into the fork bridges.*

Coat a new O-ring with fork fluid and install it into the fork cap groove.

Install the fork cap into the fork tube.



### LEFT FORK LEG NEEDLE BEARING REPLACEMENT

Remove the dust seals from the fork slider.

Press the needle bearings out of the fork slider using the special tools and a hydraulic press.

#### TOOL:

**Needle bearing remover**      **07946-KA50000**

**Assembly collar**              **07965-166030A**



Apply grease to the needle rollers of the new bearings.

Carefully press the needle bearings in the fork slider until the depth from the fork slider outer surfaces is specified value, using the same tool and a hydraulic press.

**SPECIFIED DEPTH: 3.5 mm (1.4 in)**

Apply grease to the new dust seal lips and install the seal until it is fully seated.

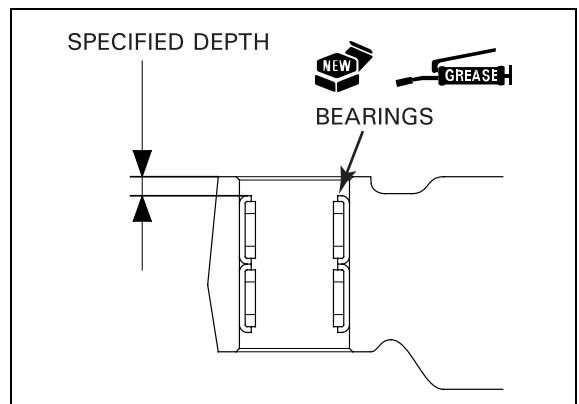

## RIGHT FORK DISASSEMBLY

Remove the two bolts and front fender mounting plate.  
Remove the axle holder bolts.

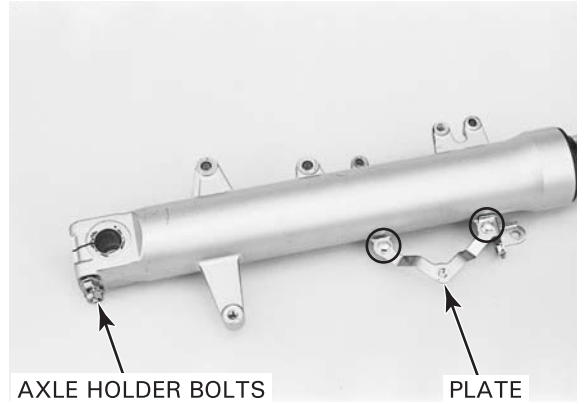

Remove the fork cap from the fork tube.



Hold the fork damper lock nut and remove the fork cap from the fork damper.  
Remove the O-ring from the fork cap.

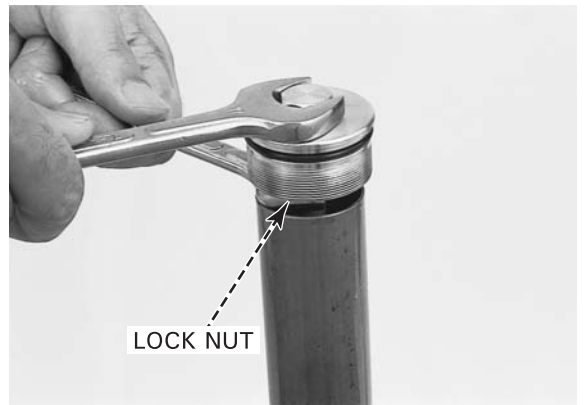

Remove the following:

- spacer
- spring seat
- fork spring

Pour out the fork fluid by pumping the fork tube up and down several times.

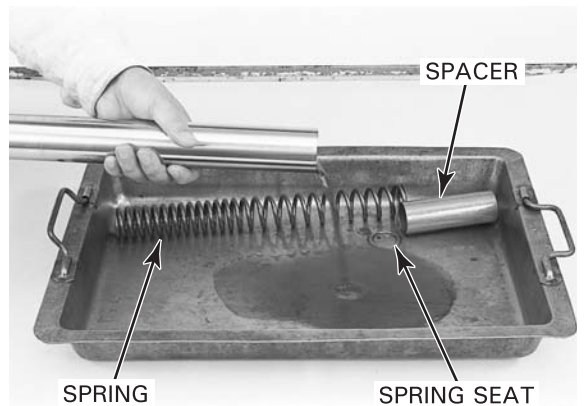

## FRONT WHEEL/SUSPENSION/STEERING

If the fork damper turns with the center bolt, temporarily install the fork spring, spring seat, spacer and fork cap.

Hold the fork slider in a vise with soft jaws or a shop towel and remove the center bolt and sealing washer.

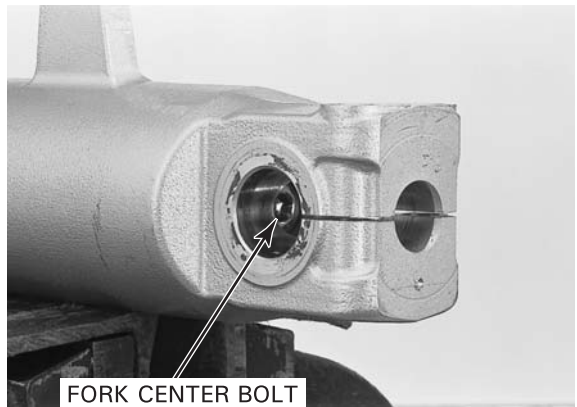

Remove the dust seal.  
Remove the stopper ring being careful not to scratch the fork tube sliding surface.

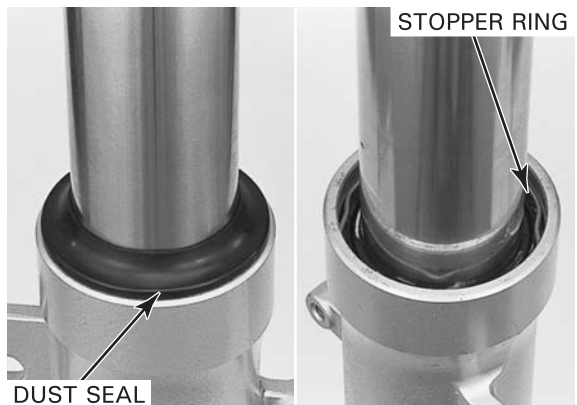

Using quick successive motions, pull the fork tube out of the fork slider.

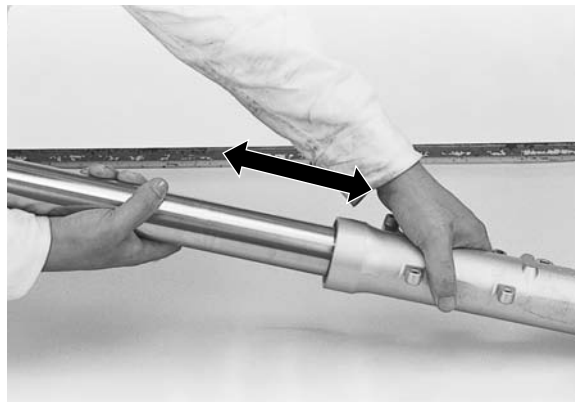

Remove the fork damper and rebound spring from the fork tube.  
Remove the oil lock piece.

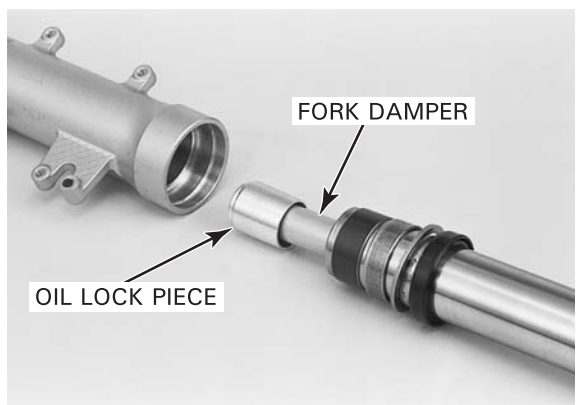

Remove the oil seal, back-up ring and guide bushing from the fork tube.

*Do not remove the slider bushing unless it is necessary to replace it with a new one.*

Carefully remove the slider bushing by prying the slot with a screwdriver until the bushing can be pulled off by hand.

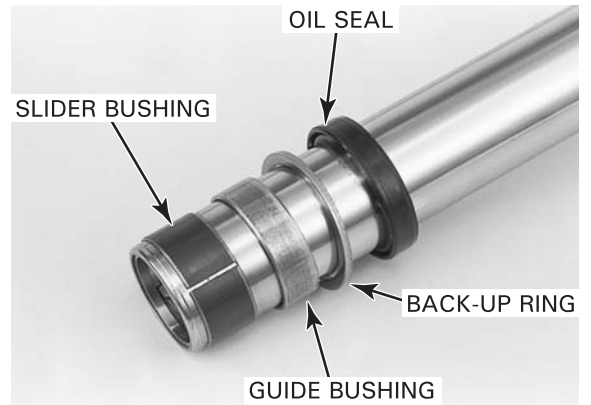

### RIGHT FORK LEG INSPECTION

#### FORK SPRING

Measure the fork spring free length.

**SERVICE LIMIT: 328.6 mm (12.94 in)**

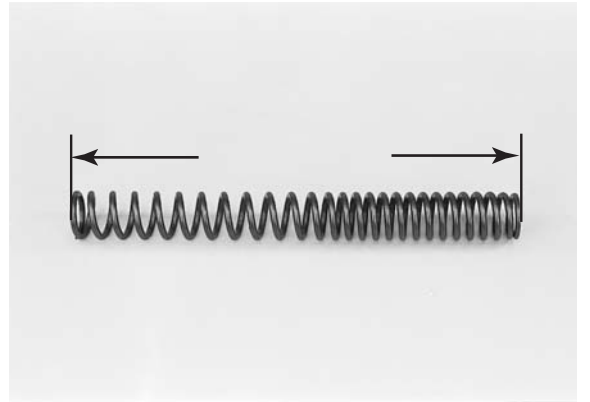

#### FORK TUBE/SLIDER/DAMPER

Check the fork tube, slider and fork damper for score marks, and excessive or abnormal wear. Check the rebound spring for fatigue or damage.

Replace the component if necessary.



Set the fork tube in V-blocks and measure the fork tube runout with a dial indicator.

Actual runout is 1/2 the total indicator reading.

**SERVICE LIMIT: 0.20 mm (0.008 in)**

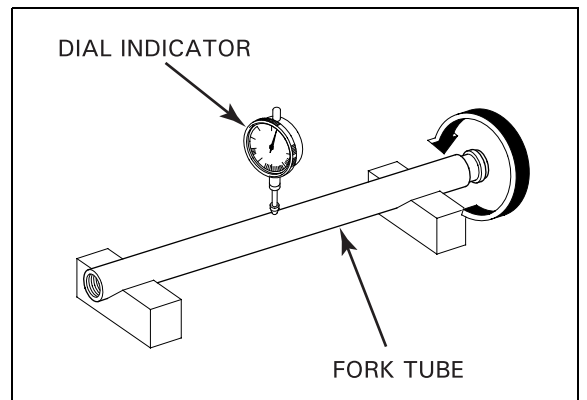

## FRONT WHEEL/SUSPENSION/STEERING

Visually inspect the slider and guide bushings. Replace the bushings if there is excessive scoring or scratching, or if the teflon is worn so that the copper surface appears on more than 3/4 of the entire surface.

Check the back-up ring; replace it if there is any distortion at the points shown.

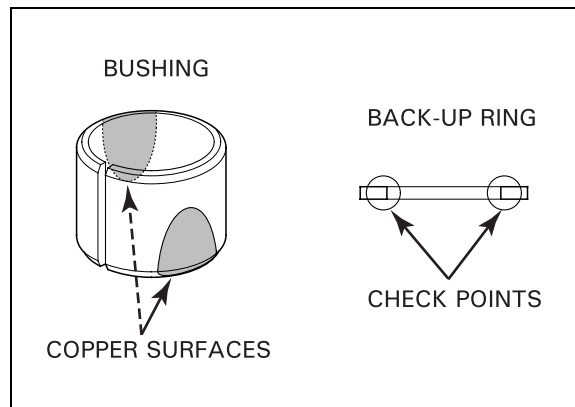

### RIGHT FORK LEG ASSEMBLY

Before assembly, wash all parts with a high flash point or non-flammable solvent and wipe them off completely.

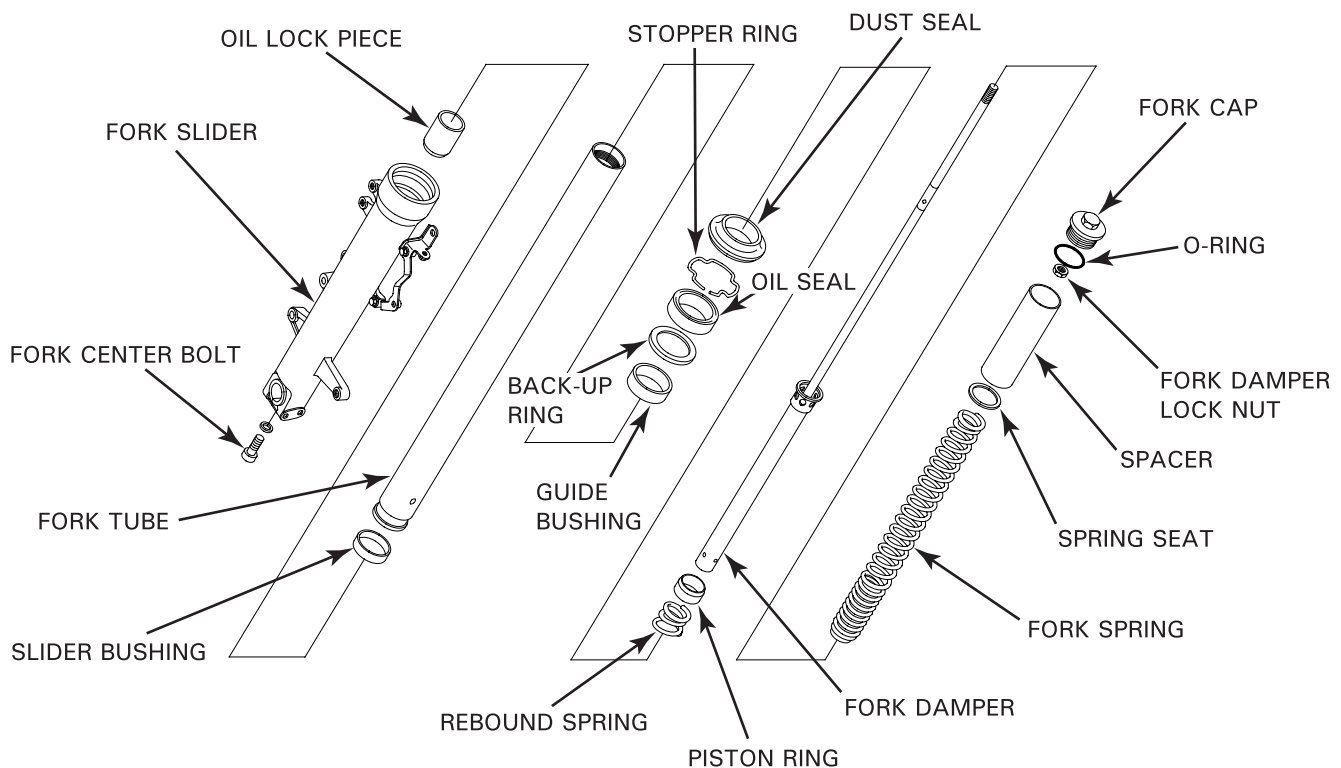

*Be careful not to damage the coating of the bushing. Do not spread open the bushing more than necessary.*

Install a new slider bushing if the bushing has been removed.

#### NOTE:

- Remove the burrs from the bushing mating surface, being careful not to peel off the coating.

Install the guide bushing and install the back-up ring with its chamfered surface side facing down.

Apply fork fluid to a new oil seal lip.

Install the oil seal with the marked side facing up.

Install the rebound spring onto the fork damper.

Install the fork damper into the fork tube.

Install the oil lock piece onto the damper end.

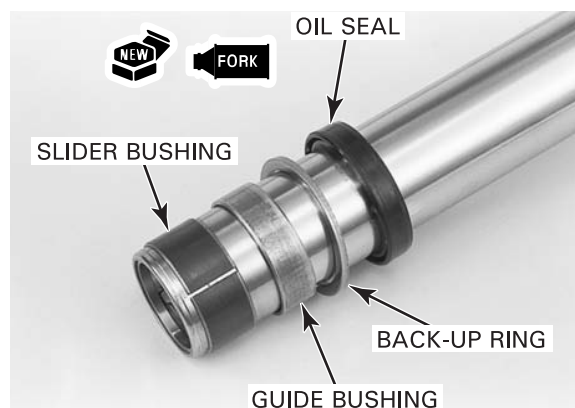



Install the fork tube into the fork slider.

*If the fork damper turns with the center bolt, temporarily install the fork spring, spring seat, spacer and fork cap.*

Hold the fork slider in a vise with soft jaws or a shop towel. Apply locking agent to the center bolt threads. Install the center bolt with a new sealing washer and tighten it to the specified torque.

**TORQUE: 20 N·m (2.0 kgf·m, 14 lbf·ft)**

Drive the oil seal into the fork slider until the stopper ring groove is visible using the special tool.

**TOOL:**

**Fork seal driver, 45 mm**

**07KMD-KZ30100  
07KMD-KZ3010A  
(U.S.A. only)**

Install the stopper ring into the groove in the fork slider being careful not to scratch the fork tube sliding surface.

Apply fork fluid to the lip of a new dust seal and install the dust seal.

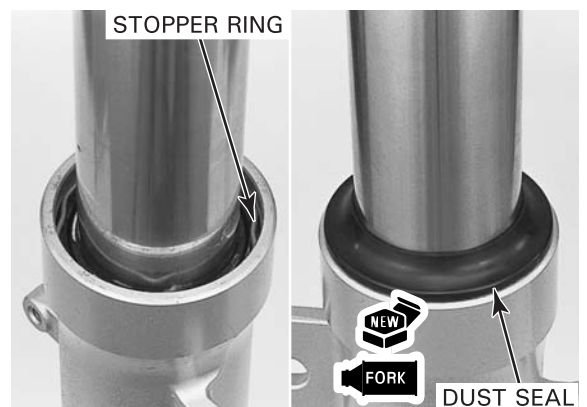
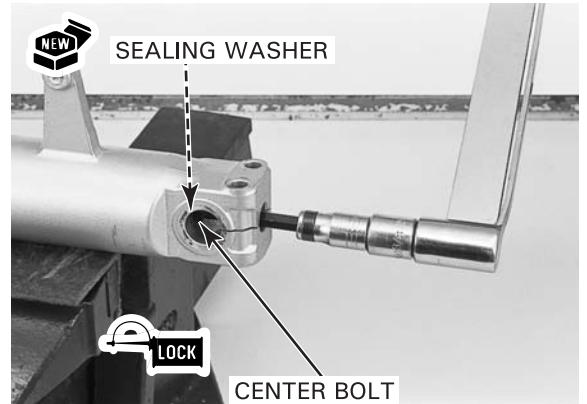
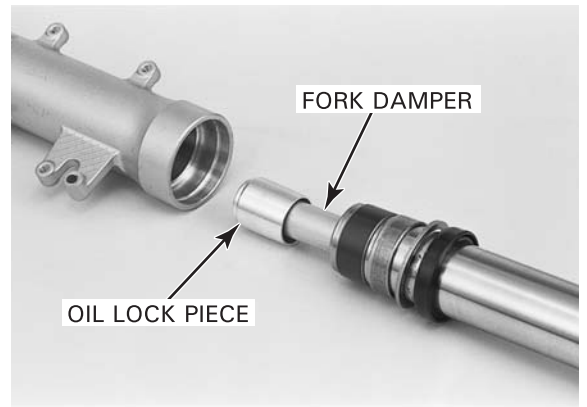

## FRONT WHEEL/SUSPENSION/STEERING

Pour the specified amount of the recommended fork fluid into the fork tube.

**RECOMMENDED FORK FLUID:**  
**Pro Honda Suspension Fluid SS-8**

**FORK FLUID CAPACITY:**  
**485 ± 2.5 cm<sup>3</sup> (16.4 ± 0.08 US oz,**  
**17.1 ± 0.09 Imp oz)**

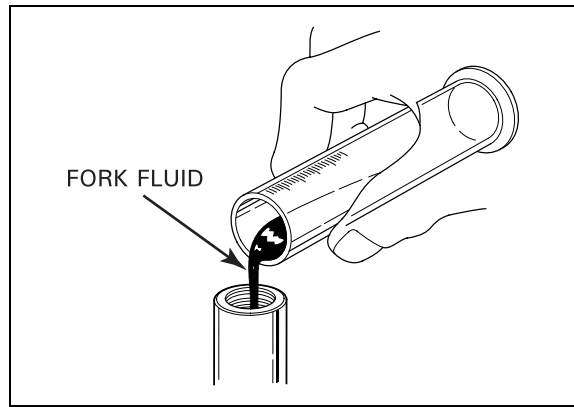

Slowly pump the fork tube several times to remove any trapped air from the lower portion of the fork tube.

Compress the fork tube fully.  
Measure the oil level from the top of the fork tube.

**FORK FLUID LEVEL: 128 mm (5.0 in)**

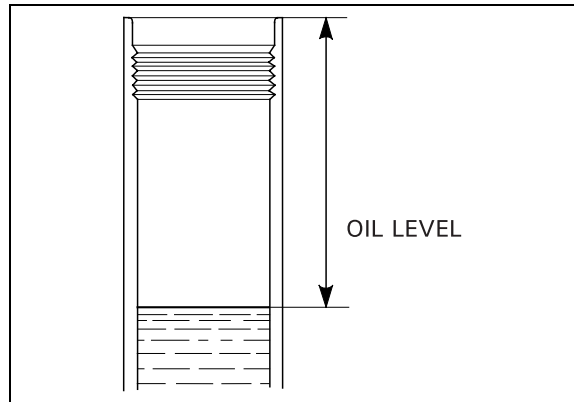

Pull the fork tube up and install the fork spring with the tightly wound coil side facing down.

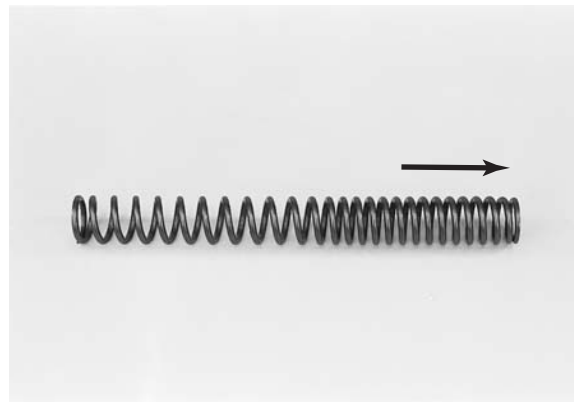

Install the spring seat and spacer.

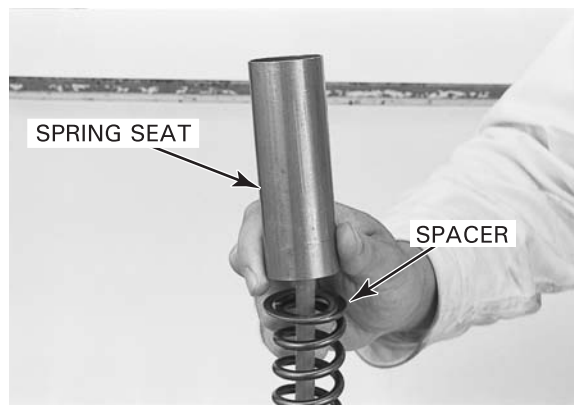

Coat a new O-ring with fork fluid and install it into the fork cap groove.  
Install the fork cap onto the fork damper.  
Hold the fork damper and screw the fork cap onto it.

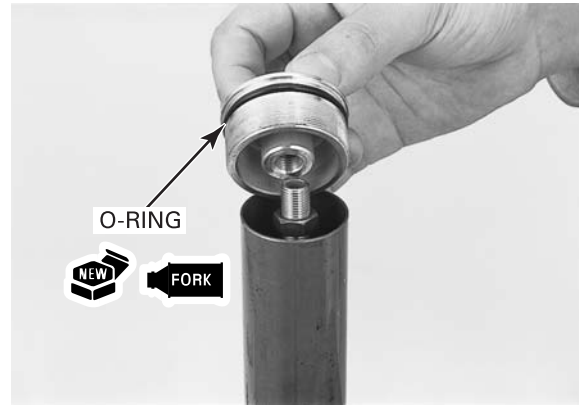

Hold the fork damper lock nut and tighten the fork cap to the specified torque.

**TORQUE:**

**Fork damper lock nut: 20 N·m (2.0 kgf·m, 14 lbf·ft)**

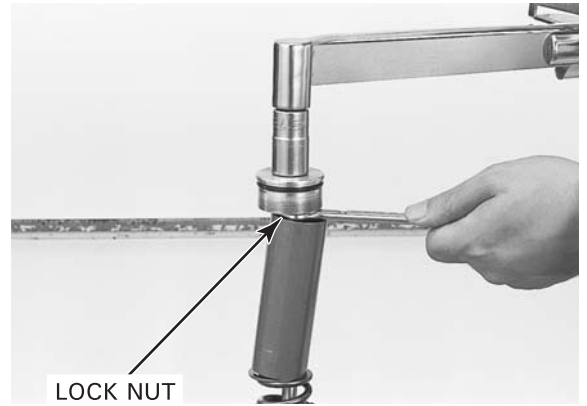

*Tighten the fork cap after installing the fork tube into the fork bridges.*

Screw the fork cap into the fork tube.



## INSTALLATION

*Route the wires, cables and hoses properly (page 1-23).*

Install the fork tubes into the fork bridges.  
Align the top of the fork tubes with the upper surface of the top bridge as shown.

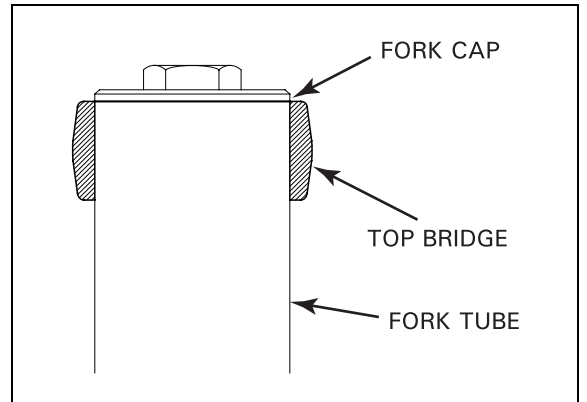

## FRONT WHEEL/SUSPENSION/STEERING

Tighten the bottom bridge pinch bolts to the specified torque.

**TORQUE: 29 N·m (3.0 kgf·m, 22 lbf·ft)**

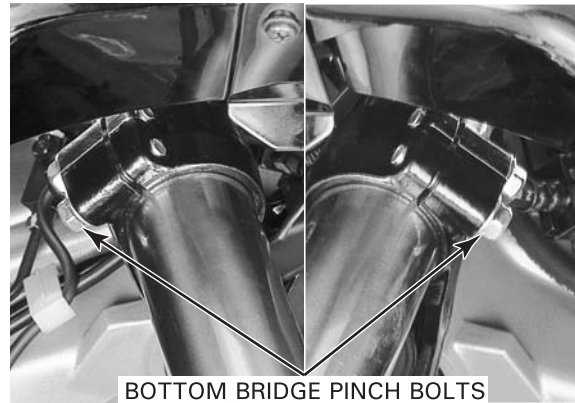

Tighten the fork caps to the specified torque.

**TORQUE: 23 N·m (2.3 kgf·m, 17 lbf·ft)**

Tighten the top bridge pinch bolts to the specified torque.

**TORQUE: 26 N·m (2.7 kgf·m, 20 lbf·ft)**

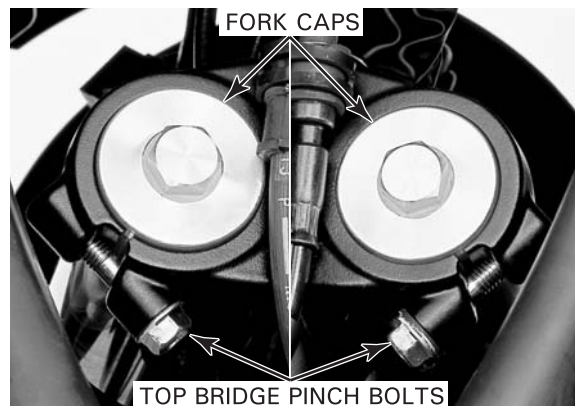

Install the secondary master cylinder onto the left fork with new mounting bolts and tighten them.

**TORQUE: 31 N·m (3.2 kgf·m, 23 lbf·ft)**

Install the brake hose joint and tighten the bolt.

**TORQUE: 12 N·m (1.2 kgf·m, 9 lbf·ft)**

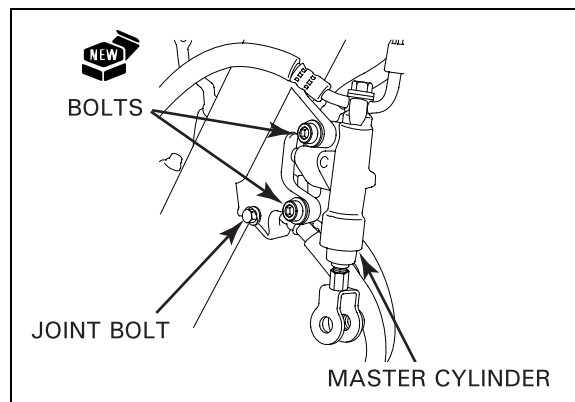

Clean the mating areas of the plunger case and front fork with compressed air, and be sure that no foreign materials are allowed.

Apply silicone grease to the anti-dive plunger tip. Install the anti-dive plunger case with new socket bolts and tighten them.

**TORQUE: 4 N·m (0.4 kgf·m, 2.9 lbf·ft)**

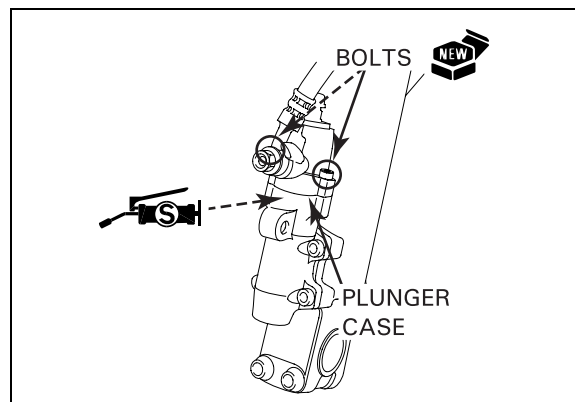

Install the following:

- delay valve and mounting bolt
- front fender B
- four fender mounting bolts with brake hose clamp

**TORQUE: Delay valve mounting bolt:  
12 N·m (1.2 kgf·m, 9 lbf·ft)**

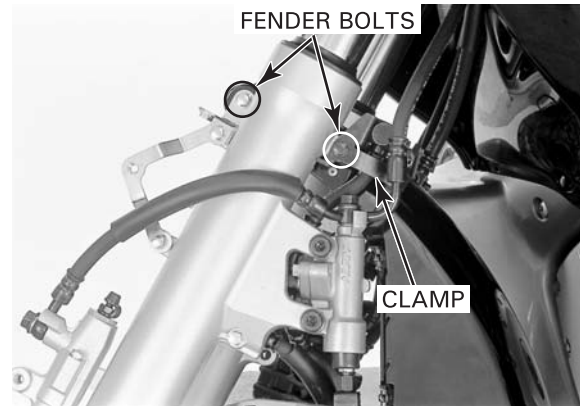
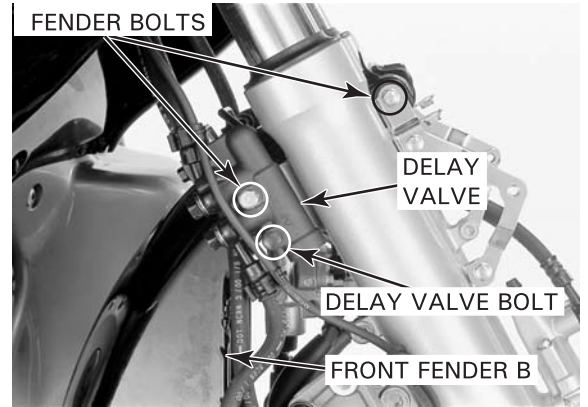

- fender top cover and two bolts
- trim clip

Install the front wheel (page 13-16).

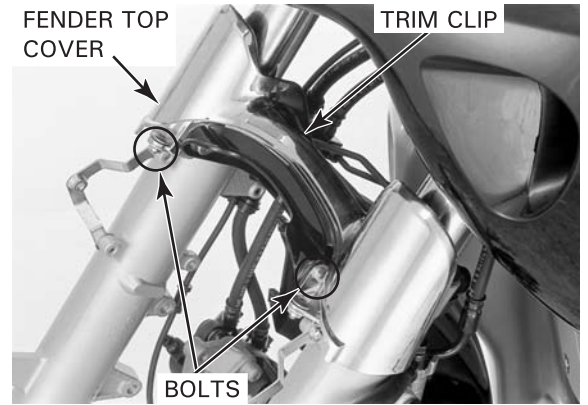

## STEERING STEM

### REMOVAL

Remove the combination meter (page 20-17).  
Remove the handlebar center cover (page 13-7).

*Keep the brake and clutch reservoir upright to prevent air from entering the hydraulic system.*

Remove the two bolts and hydraulic hose clamp.  
Remove the handlebar mounting bolts.

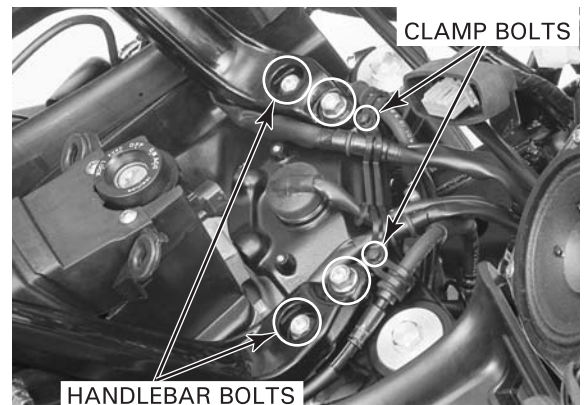



## FRONT WHEEL/SUSPENSION/STEERING

Remove the steering stem nut cap and disconnect the turn signal cancel unit connector.

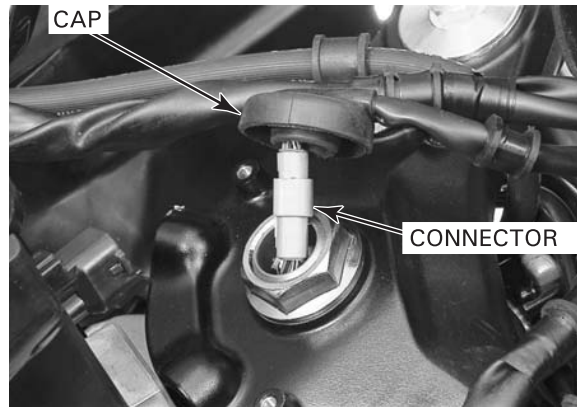

Loosen the steering stem nut.  
Remove the fork legs (page 13-24).  
Remove the steering stem nut and top bridge.

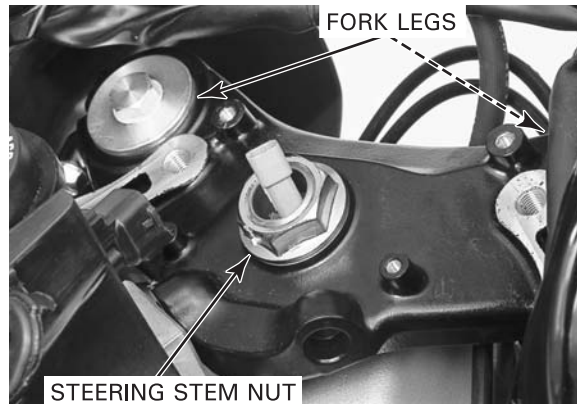

Remove the following:

- two bolts
- two screws

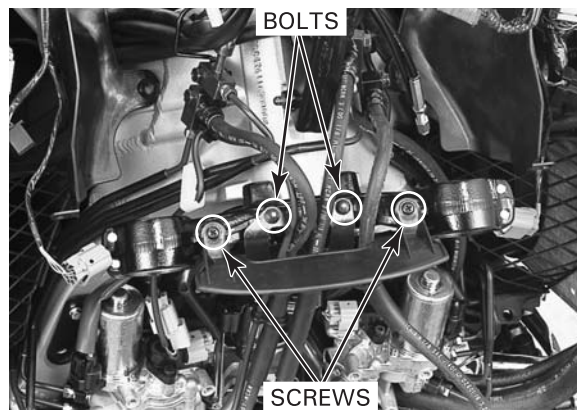

- three screws
- turn signal cancel unit
- wind protector

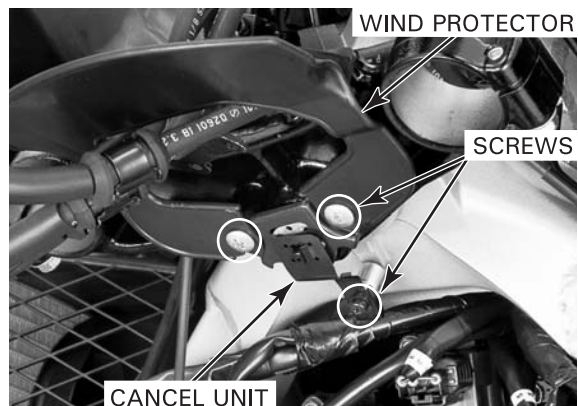



## FRONT WHEEL/SUSPENSION/STEERING

Straighten the lock washer tabs.  
Remove the steering bearing adjustment nut, lock nut and lock washer.

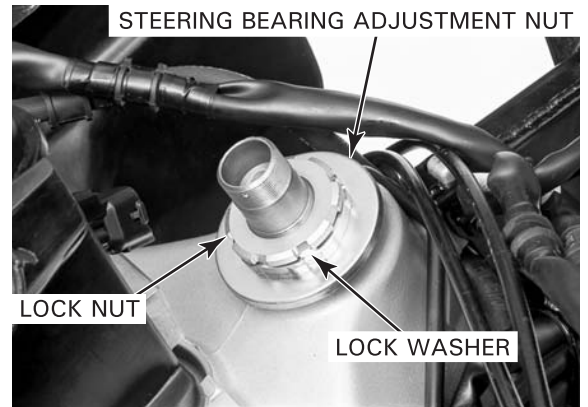

Remove the steering bearing adjustment nut using the special tool.

**TOOL:**

**Steering stem socket**

**07916-3710101 or  
07916-3710100**



Remove the following:

- dust seal



- upper bearing inner race
- steering stem
- upper bearing

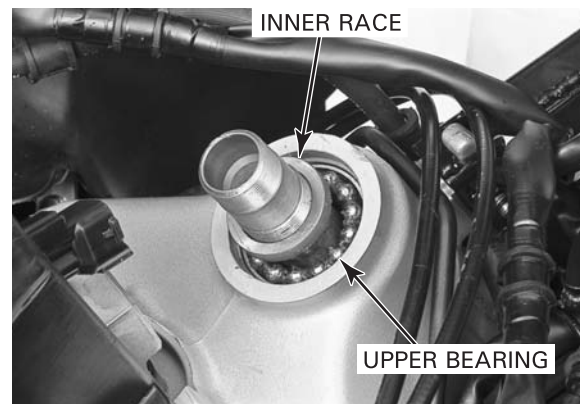

## FRONT WHEEL/SUSPENSION/STEERING

- lower bearing from the steering stem

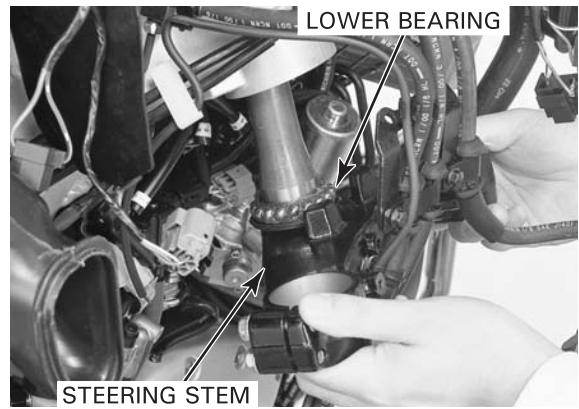

### STEERING BEARING REPLACEMENT

*Always replace the bearings and races as a set.*

Replace the steering bearing outer races using the special tools listed below.

#### TOOLS:

<b>Main bearing driver attachment</b>	<b>07946-ME90200</b>
<b>Fork seal driver weight</b>	<b>07947-KA50100</b>
<b>Oil seal driver</b>	<b>07965-MA60000</b>
<b>Installer shaft</b>	<b>07VMF-KZ30200</b>
<b>Installer attachment A</b>	<b>07VMF-MAT0100</b>
<b>Remover attachment A</b>	<b>07VMF-MAT0300</b>
<b>Remover attachment B</b>	<b>07VMF-MAT0400</b>
<b>Installer attachment B</b>	<b>07ZMF-MCAA100</b>

Install the special tools into the steering head pipe as shown.

Align remover attachment A with the groove in the steering head.

While holding the installer shaft with the wrench, turn the upper nut gradually to remove the upper bearing outer race.

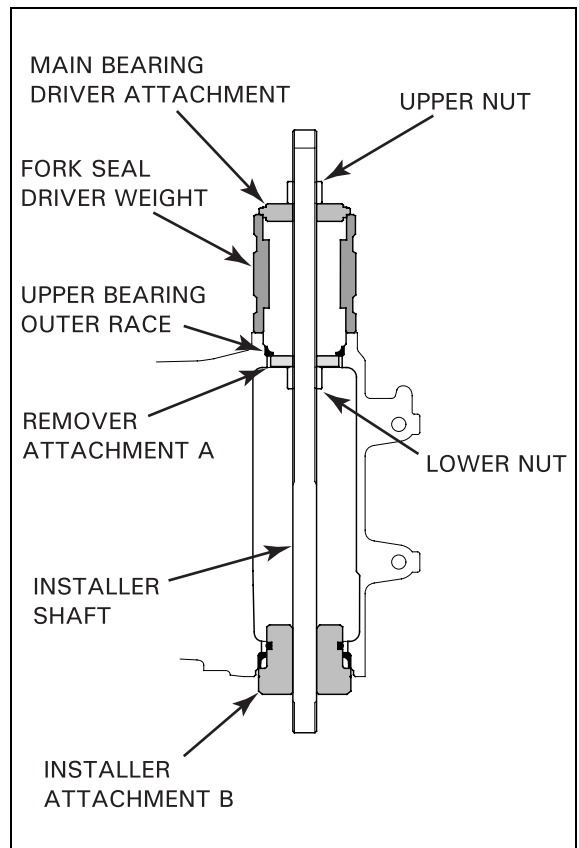

## FRONT WHEEL/SUSPENSION/STEERING

Install the special tools into the steering head pipe as shown.  
Align remover attachment B with the groove in the steering head.  
While holding the installer shaft with the wrench, turn the lower nut gradually to remove the lower bearing outer race.

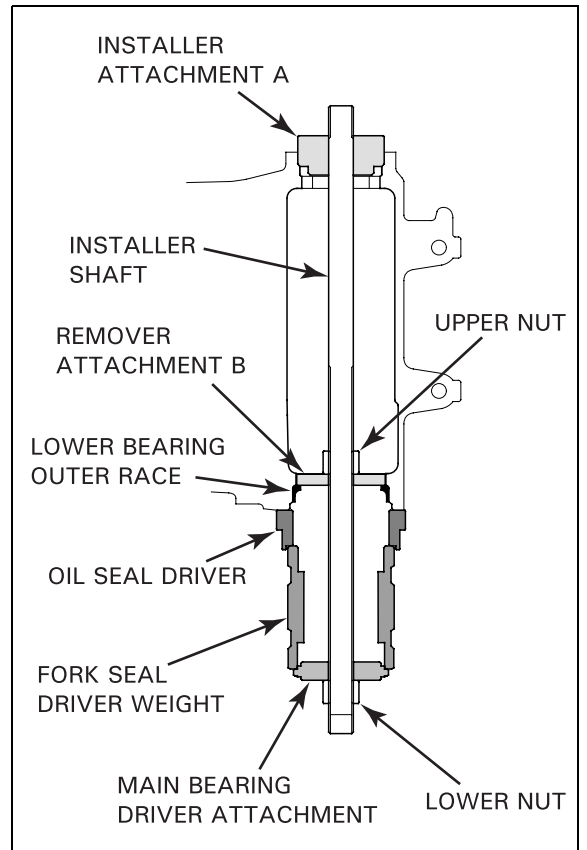

Install a new upper bearing outer race and the special tools as shown.  
While holding the installer shaft with the wrench, turn the lower nut gradually until the outer race bottoms on the steering head pipe.

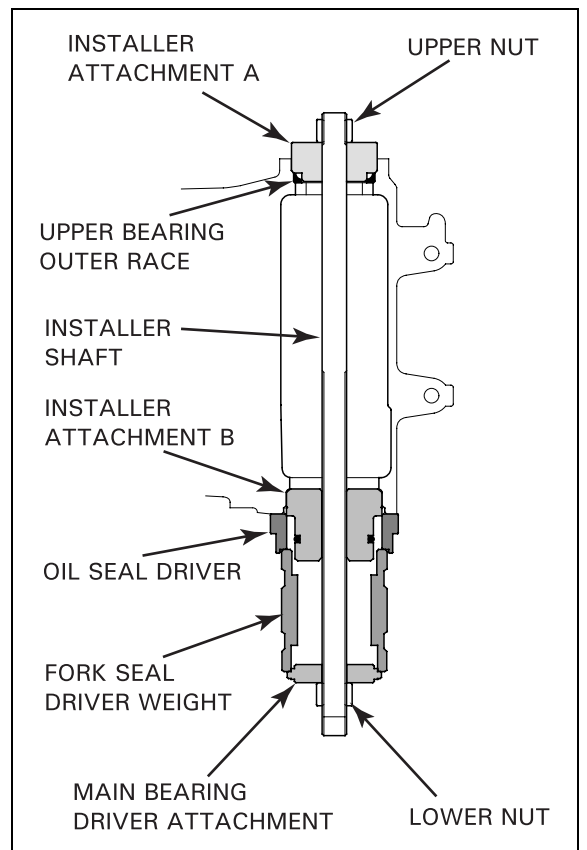

## FRONT WHEEL/SUSPENSION/STEERING

Install a new lower bearing outer race and the special tools as shown. While holding the installer shaft with the wrench, turn the upper nut gradually until the outer race bottoms on the steering head pipe.

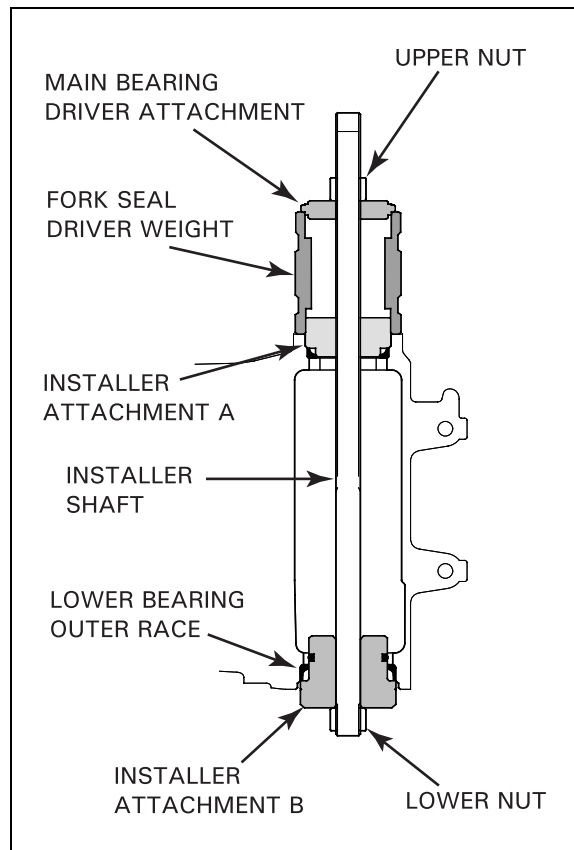

Install the stem nut onto the stem to prevent the threads from being damaged when removing the lower bearing inner race from the stem. Remove the lower bearing inner race with a chisel or equivalent tool, being careful not to damage the stem. Remove the dust seal.



Apply grease to a new dust seal lip and install it onto the steering stem. Press a new lower bearing inner race onto the steering stem using the special tools.

### TOOL:

Attachment, 35 mm

07746-0030400



**INSTALLATION**

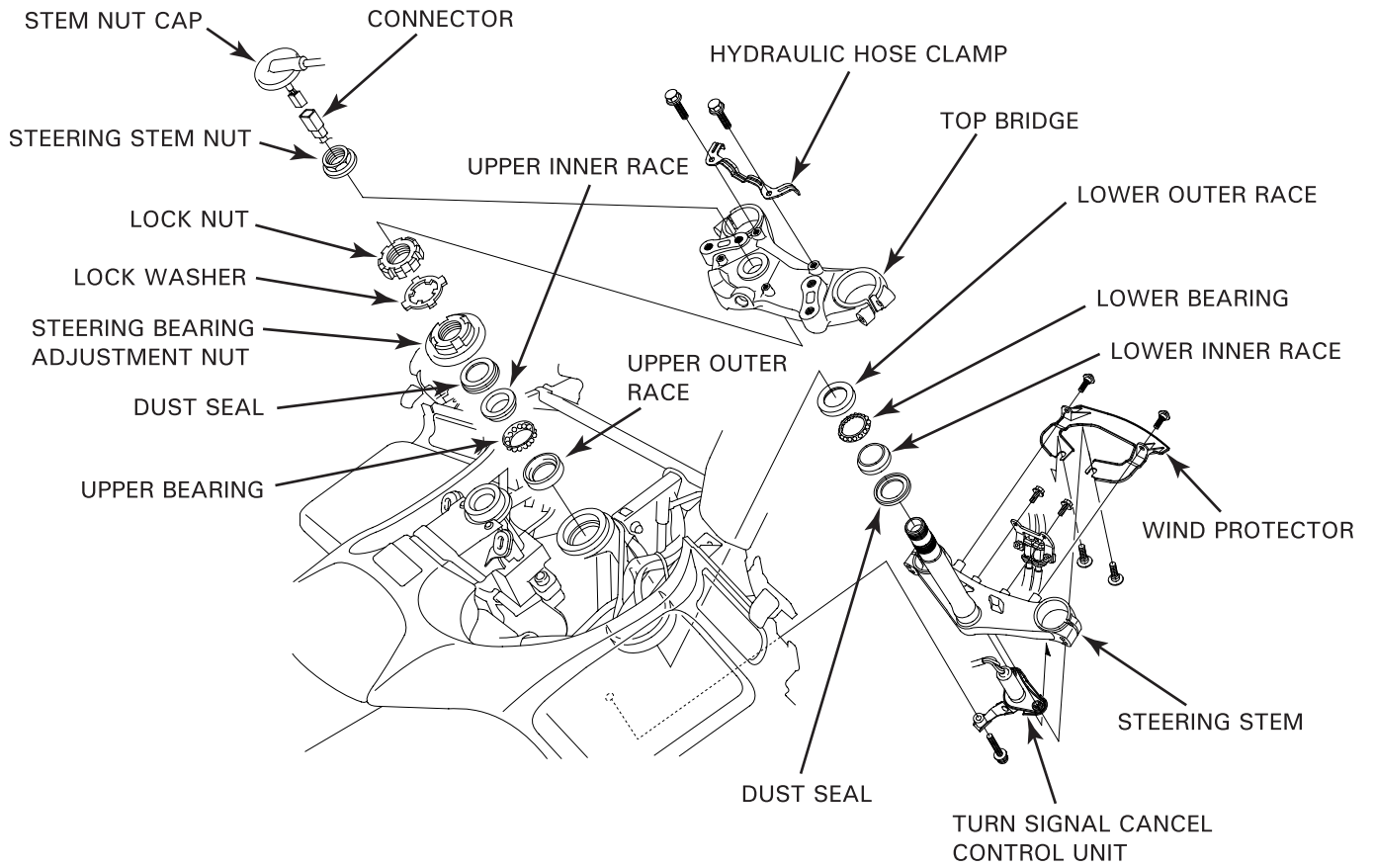

Apply grease to the steering bearings and bearing races.  
 Install the lower bearing onto the steering stem.  
 Install the steering stem into the steering head pipe.

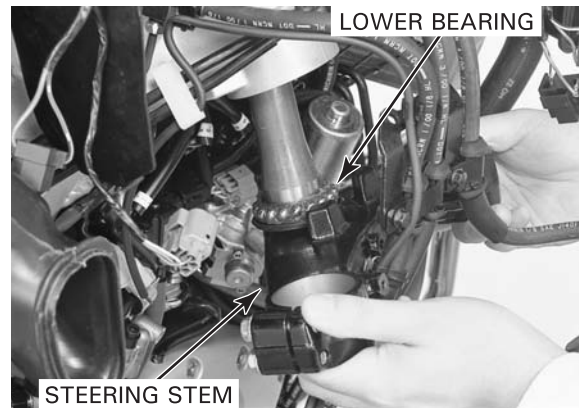

Install the upper bearing and inner race.

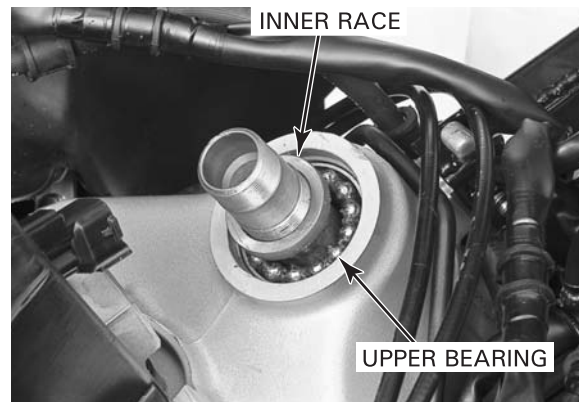

## FRONT WHEEL/SUSPENSION/STEERING

Apply grease to a new dust seal lip and install it.



Apply engine oil to the steering bearing adjustment nut threads and install it.



1. Tighten the steering bearing adjustment nut to the specified torque.

**TOOL:**

**Steering stem socket**      **07916-3710101 or  
07916-3710100**

**TORQUE: 27 N·m (2.8 kgf·m, 20 lbf·ft)**

2. Loosen the steering bearing adjustment nut and retighten it to the same torque.



3. Turn the steering stem left and right, lock-to-lock at least four times to seat the bearings.

Retighten the adjustment nut to the same torque.

4. Repeat step 3.





## FRONT WHEEL/SUSPENSION/STEERING

Install a new lock washer and bend the two opposite tabs down into the grooves in the steering bearing adjustment nut.

Install and finger tighten the lock nut all the way. Hold the steering bearing adjustment nut and further tighten the lock nut, within 90 degrees, to align its grooves with the tabs of the lock washer. Bend up the lock washer tabs into the grooves of the lock nut.



Put the turn signal cancel unit wire through the steering stem.

Install the following:

- wind protector
- turn signal cancel unit
- three screws

Tighten the screws.

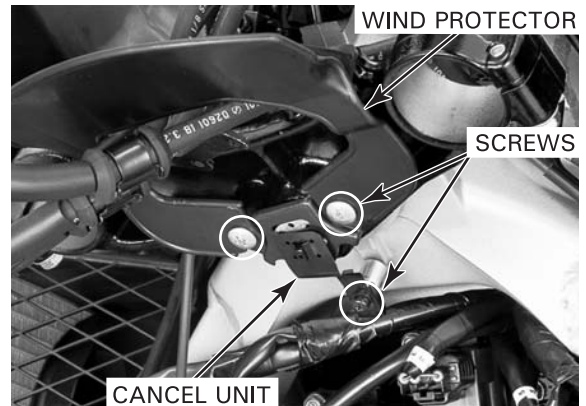

Install the two screws and two bolts and tighten them.

**TORQUE: Clamp bolt: 12 N·m (1.2 kgf·m, 9 lbf·ft)**

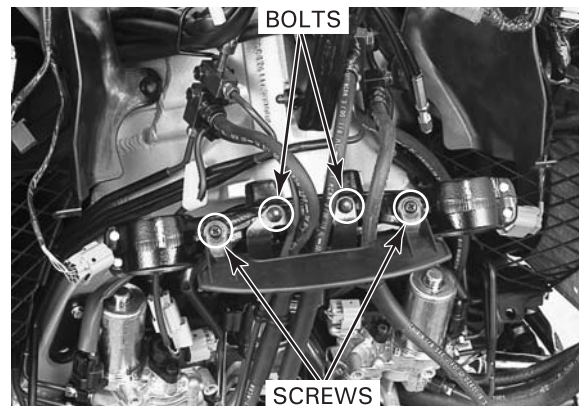

Install the top bridge and steering stem nut.

Temporarily install the fork legs into the fork bridges.

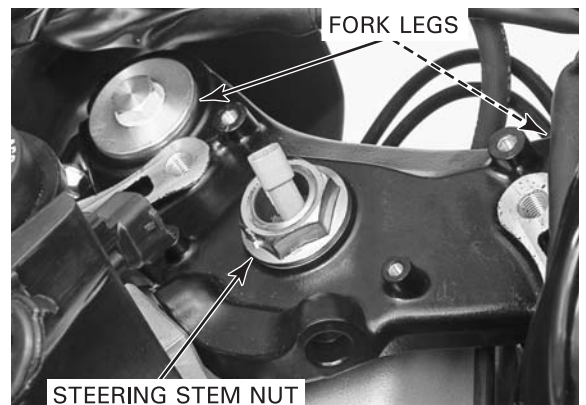

## FRONT WHEEL/SUSPENSION/STEERING

Tighten the steering stem nut to the specified torque.

**TORQUE: 103 N·m (10.5 kgf·m, 76 lbf·ft)**

Remove the fork legs.  
Make sure that the steering stem moves smoothly, without play or binding.

Install the forks legs (page 13-24).



Connect the turn signal cancel unit connector and install the steering stem nut cap.

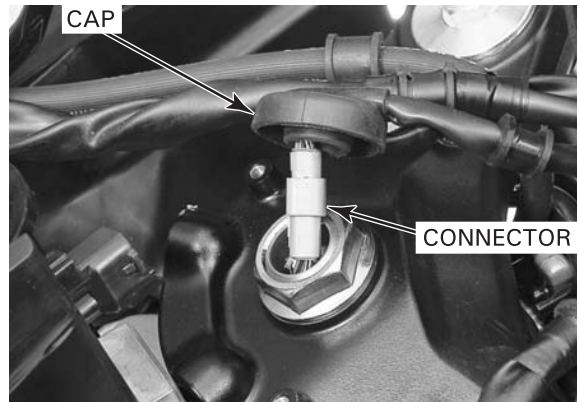

Install the hydraulic hose clamp with the two bolts and tighten the bolts.

Place the left and right handlebars onto the top bridge and align the bolt holes, then install the handlebar mounting bolts and tighten them to the specified torque.

**TORQUE: 26 N·m (2.7 kgf·m, 20 lbf·ft)**

Install the handlebar center cover (page 13-7).  
Install the combination meter (page 20-17).

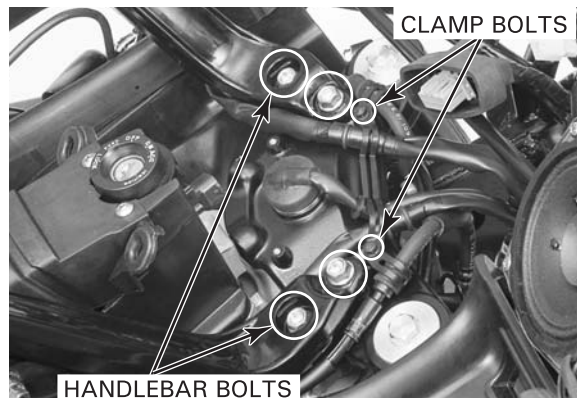

### STEERING BEARING PRE-LOAD

Remove the front fairing (page 2-10).

Support the motorcycle securely using safety stands or a hoist and raise the front wheel off the ground.

Position the steering stem to the straight ahead position.

Hook a spring scale to the fork tube between the fork top and bottom bridges.

Make sure there is no cable, wire harness or hose interference.

Pull the spring scale keeping it at a right angle to the steering stem.

Read the scale at the point where the steering stem just starts to move.

### STEERING BEARING PRE-LOAD:

**8.8 – 13.7 N (0.9 – 1.4 kgf, 2.0 – 3.1 lbf)**

If the readings do not fall within the limits, readjust the steering bearing adjustment.

Install the front fairing (page 2-10).

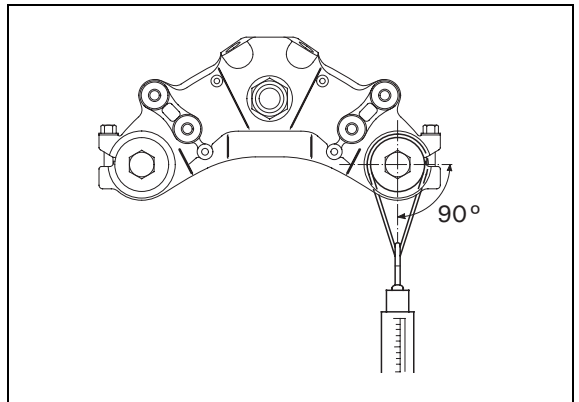

# 14. REAR WHEEL/SUSPENSION

---

COMPONENT LOCATION .....	14-2	SHOCK ABSORBER .....	14-16
SERVICE INFORMATION .....	14-3	SUSPENSION LINKAGE .....	14-18
TROUBLESHOOTING .....	14-5	SWINGARM .....	14-22
REAR WHEEL .....	14-14	SUSPENSION LEVEL RELAY .....	14-29

# REAR WHEEL/SUSPENSION

## COMPONENT LOCATION

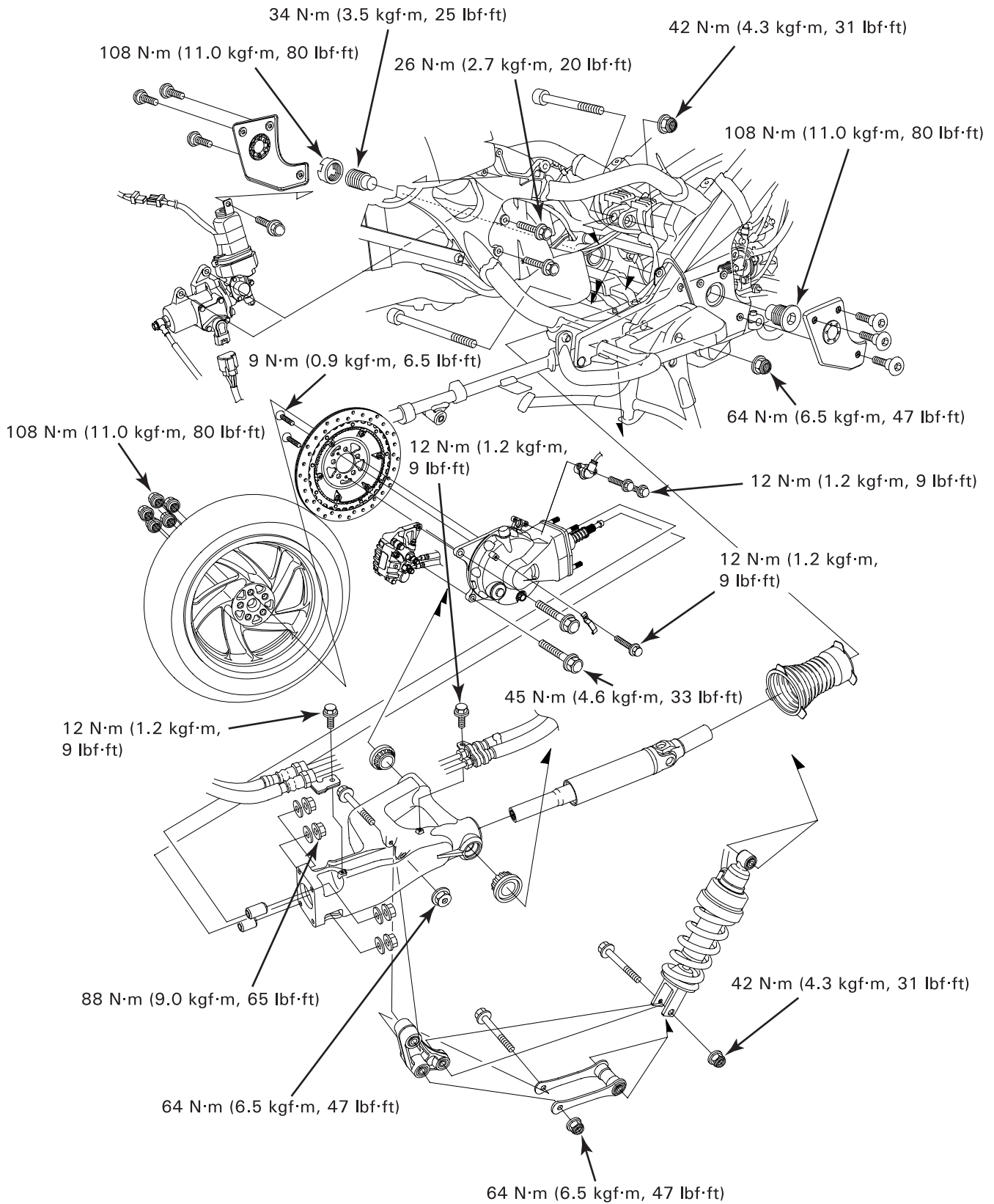

# SERVICE INFORMATION

## GENERAL

- Riding on damaged rims impairs safe operation of the vehicle.
- When servicing the rear wheel, shock absorber, or swingarm, raise the rear wheel off the ground by supporting the frame securely.
- A contaminated brake disc or pad reduces stopping power. Discard contaminated pads and clean a contaminated disc with a high quality brake degreasing agent.

### NOTICE

- *The shock absorber contains nitrogen gas under high pressure. Do not allow fire or heat near the shock absorber.*
- *Before discarding the shock absorber, release the nitrogen.*
- *The damper unit is filled with nitrogen gas under high pressure, do not try to disassemble.*
- Use only genuine Honda replacement bolts and nuts for all suspension pivot and mounting points.
- When using the lock nut wrench, use a deflecting beam type torque wrench 20 inches long. The lock nut wrench increases the torque wrench's leverage, so the torque wrench reading will be less than the torque actually applied to the lock nut. The specification given on page 14-3 is the actual torque applied to the lock nut, not the reading on the torque wrench when used with the lock nut wrench. The procedure later in the text gives both actual and indicated.
- After installing the rear wheel, perform the air gap inspection if the rear brake disc was removed (page 16-31).
- Refer to section 15 for hydraulic brake system service.
- The angle sensor digital pulse signal is sent to the suspension level control unit in the combination meter. For combination meter servicing, see section 19.
- The following color codes are indicated throughout this section.

Bl: Black                      G: Green                      Lg: Light Green              R: Red  
 Br: Brown                     W: White                     Bu: Blue                      Y: Yellow

## SPECIFICATIONS

Unit: mm (in)







ITEM		STANDARD	SERVICE LIMIT
Minimum tire tread depth		-	2.0 (0.08)
Cold tire pressure	Driver only	280 kPa (2.80 kgf/cm <sup>2</sup> , 41 psi)	-
	Driver and passenger	280 kPa (2.80 kgf/cm <sup>2</sup> , 41 psi)	-
Wheel rim runout	Radial	-	2.0 (0.08)
	Axial	-	2.0 (0.08)
Wheel balance weight		-	70 g (2.5 oz) max.

## TORQUE VALUES

Rear wheel nut	108 N·m (11.0 kgf·m, 80 lbf·ft)	
Rear pulser ring bolt (ABS model only)	8 N·m (0.8 kgf·m, 5.8 lbf·ft)	ALOC bolt: replace with a new one.
Rear brake disc screw	9 N·m (0.9 kgf·m, 6.5 lbf·ft)	ALOC screw: replace with a new one.
Shock absorber mounting nut	42 N·m (4.3 kgf·m, 31 lbf·ft)	U-nut.
Suspension level actuator mounting bolt	26 N·m (2.7 kgf·m, 20 lbf·ft)	
Shock arm-to-swingarm nut	64 N·m (6.5 kgf·m, 47 lbf·ft)	U-nut.
Shock arm-to-shock link nut	64 N·m (6.5 kgf·m, 47 lbf·ft)	U-nut.
Shock link-to-frame nut	64 N·m (6.5 kgf·m, 47 lbf·ft)	U-nut.
Swingarm right pivot bolt	108 N·m (11.0 kgf·m, 80 lbf·ft)	
Swingarm left pivot bolt	34 N·m (3.5 kgf·m, 25 lbf·ft)	
Swingarm left pivot lock nut	108 N·m (11.0 kgf·m, 80 lbf·ft)	
Rear brake light/cruise cancel switch holder screw	2 N·m (0.2 kgf·m, 1.4 lbf·ft)	Apply locking agent to the threads.
Brake hose pipe clamp bolt (swing arm)	12 N·m (1.2 kgf·m, 9 lbf·ft)	

# REAR WHEEL/SUSPENSION

## TOOLS:

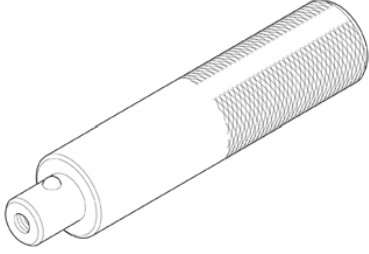
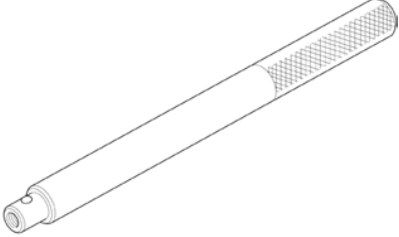
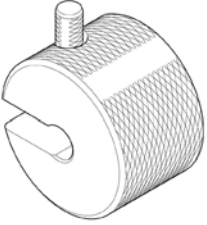
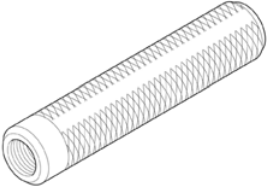
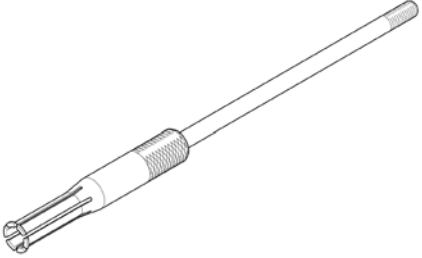
<p>Attachment, 32 x 35 mm 07746-0010100</p>  <p>used with 3/8" x 16 mm thread slide hammer (commercially available in U.S.A.)</p>	<p>Attachment, 42 x 47 mm 07746-0010300</p> 	<p>Attachment, 24 x 26 mm 07746-0010700</p> 
<p>Attachment, 22 x 24 mm 07746-0010800</p> 	<p>Attachment, 28 x 30 mm 07946-1870100</p> 	<p>Pilot, 17 mm 07746-0040400</p> 
<p>Pilot, 20 mm 07746-0040500</p> 	<p>Driver 07749-0010000</p> 	<p>Driver 07949-3710001</p> 
<p>Remover weight 07741-0010201</p>  <p>or 07936-371020A or 07936-3710200 (U.S.A. only)</p>	<p>Remover handle 07936-3710100</p> 	<p>Bearing remover, 20 mm 07936-3710600</p> 



Lock nut wrench, 9 x 45 mm  
07ZMA-MCA0100

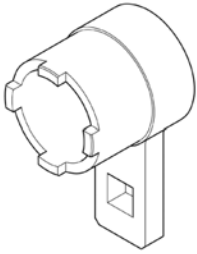

## **TROUBLESHOOTING**

### **Soft suspension**

- Weak shock absorber spring
- Incorrect suspension adjustment
- Oil leakage from damper unit
- Insufficient tire pressure

### **Hard suspension**

- Incorrect suspension adjustment
- Damaged rear suspension pivot bearings
- Improperly tightened swingarm pivot
- Bent damper rod
- Tire pressure too high

### **Rear suspension noise**

- Faulty rear shock absorber
- Loose rear suspension fasteners
- Worn rear suspension pivot bearings

### **Rear wheel wobbling**

- Bent rim
- Faulty rear tire
- Unbalanced rear tire and wheel
- Insufficient rear tire pressure
- Faulty swingarm pivot bearings
- Axle fastener not tightened properly
- Low tire pressure

### **Rear wheel turns hard**

- Rear brake drag (section 15)

## REAR WHEEL/SUSPENSION

### SHOCK ABSORBER SPRING PRE-LOAD ADJUSTMENT SYSTEM

#### NOTE:

- This electric shock absorber spring pre-load adjustment system functions with the following conditions:
  - The ignition switch is turned to "ON" or "ACC."
  - The motorcycle is stopped.
  - The transmission is in neutral.
  - The reverse system is off.
- If the transmission is shifted, the reverse system is on or the motorcycle moves above 1 km/h when the system is controlling the spring pre-load, the system will stop controlling and the pre-load position indicator bar will blink for 3 seconds.
- The spring pre-load system has 26 positions (from 0 to 25) for different road or riding conditions.

#### CIRCUIT DIAGRAM

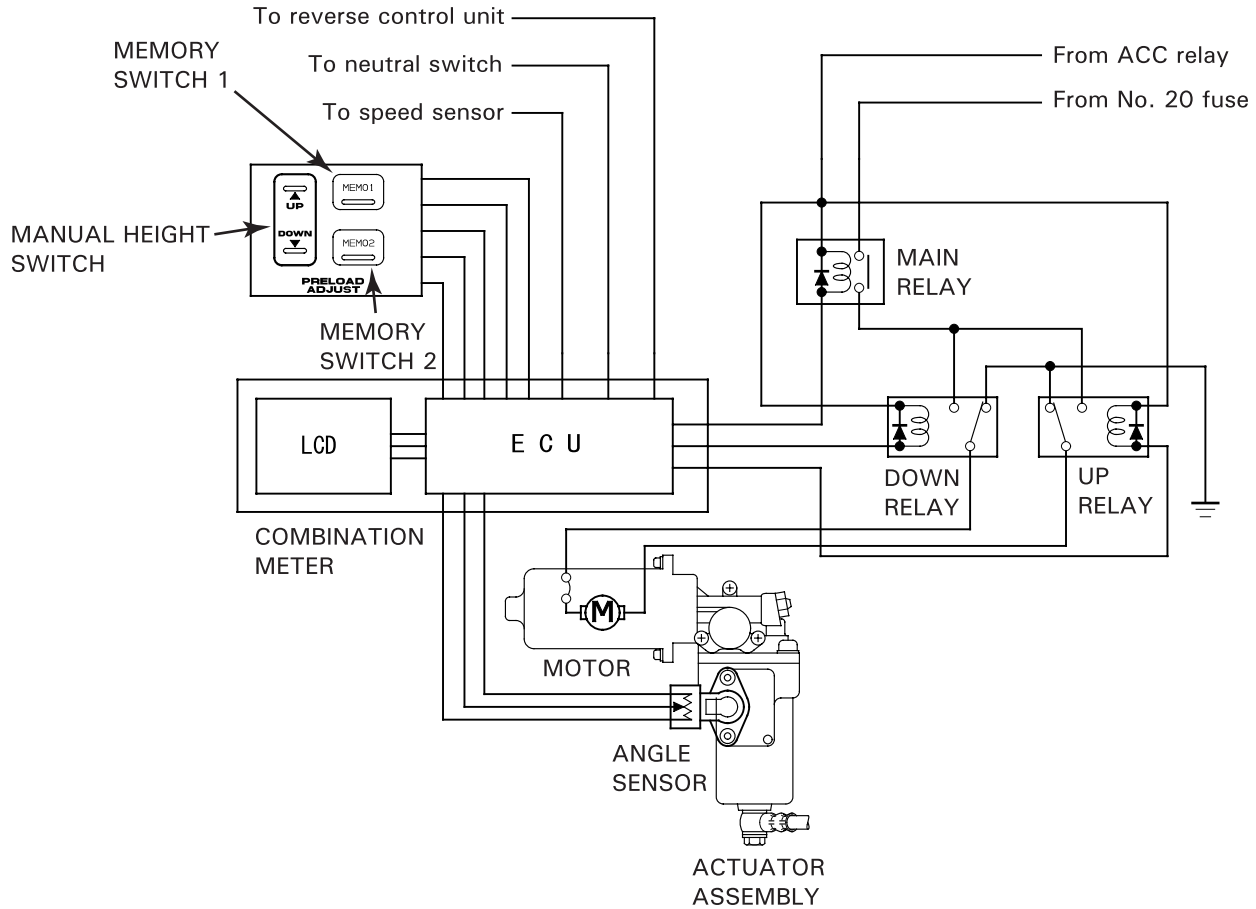

#### BEFORE TROUBLESHOOTING

- Check that the battery is fully charged and in good condition.
- Check for a blown No. 20 fuse.
- Check that the audio system functions properly.
- Check that the neutral indicator comes on when the ignition switch is turned to "ON" with the transmission in neutral.
- Check that the reverse shift switch is pushed to "OFF" (the reverse indicator stays off).

**Suspension level actuator operates and the pre-load position varies between 0 and 25 on the multi-display with the manual height switch but the suspension level does not vary**

- Pre-load adjustment hydraulic system leakage; replace the shock absorber as an assembly (page 14-16).

NOTE:

- If the "SUS ADJ ERROR" indication appears on the multi-display when the ignition switch is turned to "ON," it will go off after 30 seconds.

**Suspension level actuator does not operate with the manual height switch**

**1. Suspension System Error Indicator Inspection**

Turn the ignition switch to "ON" or "ACC" and operate the manual height switch. Check that the "SUS ADJ ERROR" indication blinks on the multi-display.

**Does "SUS ADJ ERROR" blink on the multi-display?**

**YES** – GO TO STEP 5.

**NO** – GO TO STEP 2.

**2. Manual Height Switch Operation Inspection**

Turn the ignition switch to "OFF." Remove the left fairing pocket (page 2-11). Disconnect the panel switch 14P gray connector. Check for continuity between the wire terminals of the switch side connector in each manual height switch position. Continuity should exist between the color coded wires as follows:

Color Position	Lg/Bl	G/Y	Br/W
UP	○	○	
FREE			
DOWN		○	○

**Is there continuity?**

**NO** – Faulty manual height switch; replace the panel switch assembly (page 20-32).

**YES** – GO TO STEP 3.

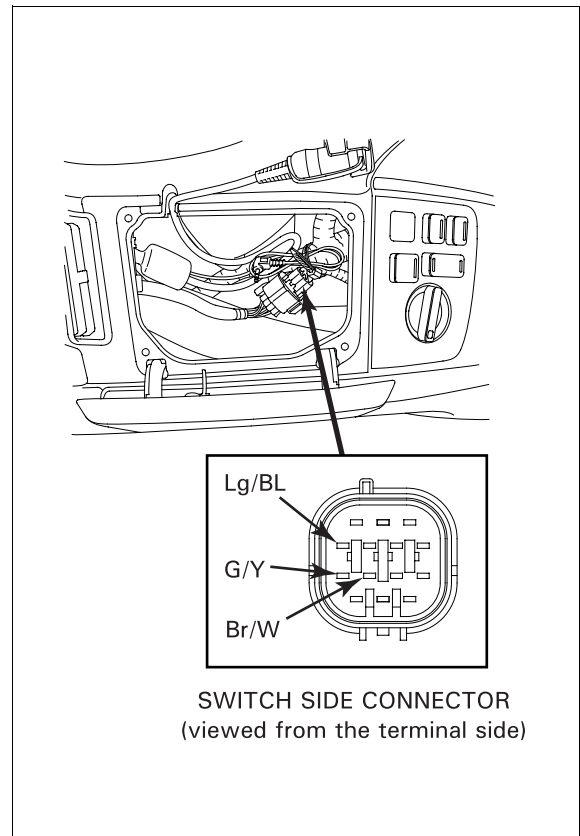

SWITCH SIDE CONNECTOR  
(viewed from the terminal side)

## REAR WHEEL/SUSPENSION

### 3. Manual Height Switch Harness Short Circuit Inspection

Remove the combination meter (page 20-17).  
Check the following wires for continuity to ground at the panel switch 14P gray connector.

- Light green/yellow
- Brown/white

#### *Is there continuity?*

**YES** - Short circuit in the fairing sub-wire harness.

**NO** - GO TO STEP 4.

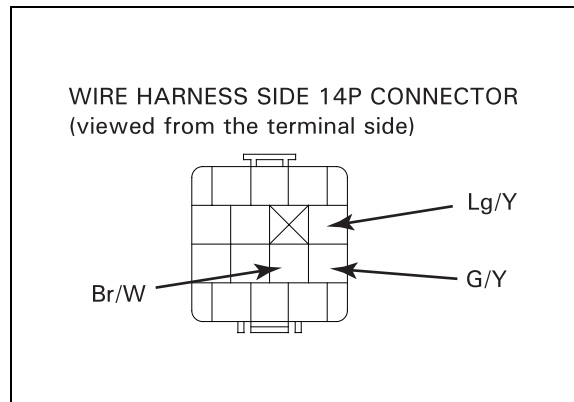

### 4. Manual Height Switch Harness Continuity Inspection

Check the following wires for continuity between the panel switch 14P gray connector and combination meter 16P black connector.

- Light green/yellow
- Brown/white
- Green/yellow

#### *Is there continuity?*

**NO** - Open circuit in the fairing sub-wire harness.

**YES** - • Loose or poor contact of the switch 14P gray connector and meter 16P black connector.  
• Faulty combination meter; replace the meter/ gauge assembly (page 20-15).

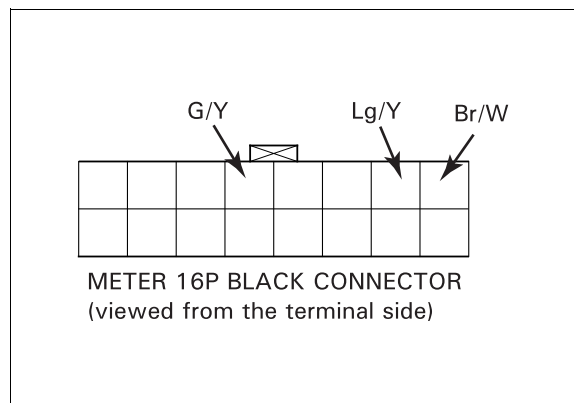

### 5. Angle Sensor Power Input and Ground Line Inspection at Combination Meter

Turn the ignition switch to "OFF."  
Remove the combination meter (page 20-17).  
Measure the angle sensor resistance between the Black/red and Blue/green wire terminals of the combination meter 16P black connector.

**STANDARD: 4.0 – 6.0 k $\Omega$  (20° C/68° F)**

#### *Is the resistance within the specified value?*

**NO** - GO TO STEP 8.

**YES** - GO TO STEP 6.

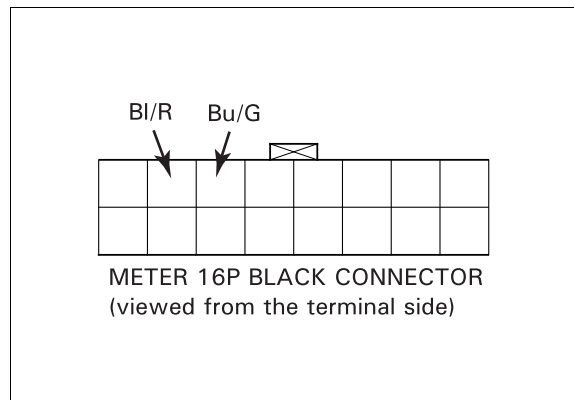

**6. Angle Sensor Signal Line Inspection at Combination Meter**

Measure the angle sensor resistance between the Yellow/red and Blue/green wire terminals of the combination meter 16P black connector.

**STANDARD: 0.4 – 5.4 kΩ (20° C/68° F)**

*Is the resistance within the specified value?*

**NO** – GO TO STEP 9.

**YES** – GO TO STEP 7.

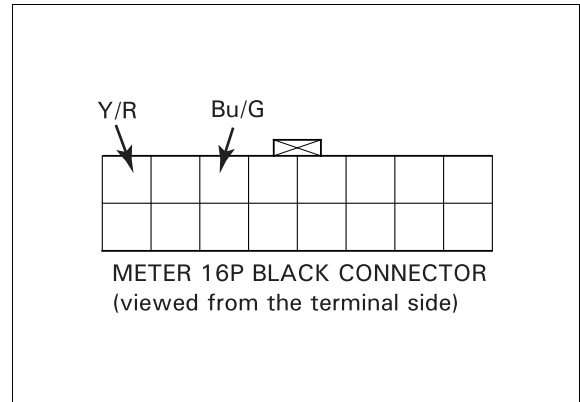

**7. Actuator Motor Operation Inspection at Suspension Level Relays**

Remove the suspension level UP and DOWN relays (page 14-29). Check the actuator motor operation by connecting a fully charged 12-V battery.

- If the angle sensor resistance measured on the previous step is 2.5 kΩ or more: Connect the battery positive (+) terminal to the UP relay connector Brown/white wire terminal and the battery negative (-) terminal to the DOWN relay connector Green wire terminal within 3 seconds (max. 3 seconds).
- If the angle sensor resistance measured on the previous step is 2.5 kΩ or less: Connect the battery positive (+) terminal to the DOWN relay connector Green wire terminal and the battery negative (-) terminal to the UP relay connector Brown/white wire terminal within 3 seconds (max. 3 seconds).

**NOTE:**

Do not connect the battery to the connector terminals for more than 3 seconds.

*Does the actuator motor operate when connected as described above?*

**NO** – GO TO STEP 12.

**YES** – GO TO STEP 10.

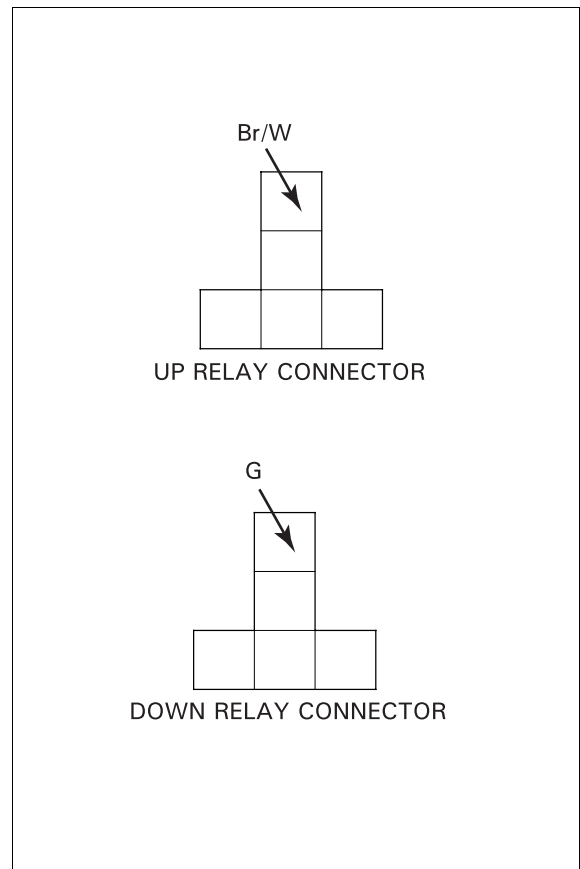

## REAR WHEEL/SUSPENSION

### 8. Angle Sensor Power Input and Ground Line Inspection at Angle

Remove the right saddlebag (page 2-15).  
Disconnect the angle sensor connector.  
Measure the angle sensor resistance between the Black/red and Blue/green wire terminals of the sensor side connector.

**STANDARD: 4.0 – 6.0 k $\Omega$  (20° C/68° F)**

***Is the resistance within the specified value?***

**NO** – Faulty angle sensor; replace the shock absorber assembly (page 14-16).

**YES** –

- Open or short circuit in the Black/red and Blue/green wires between the combination meter 16P black connector and angle sensor connector.
- Loose or poor contact of the angle sensor connector.

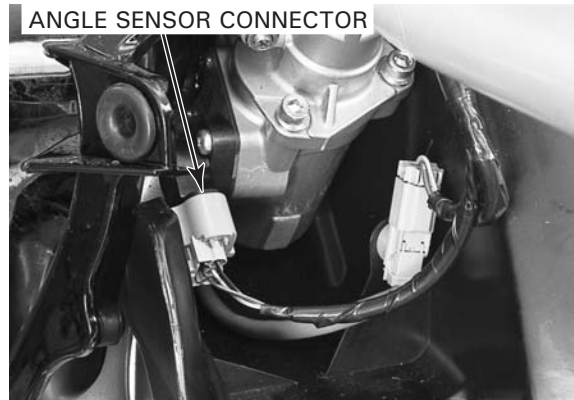

### 9. Angle Sensor Signal Line Inspection at Angle Sensor

Remove the right saddlebag (page 2-15).  
Disconnect the angle sensor connector.  
Measure the angle sensor resistance between the Yellow/red and Blue/green wire terminals of the sensor side connector.

**STANDARD: 0.4 – 5.4 k $\Omega$  (20° C/68° F)**

***Is the resistance within the specified value?***

**NO** – Faulty angle sensor; replace the shock absorber assembly (page 14-16).

**YES** –

- Open or short circuit in the Yellow/red wire between the combination meter 16P black connector and angle sensor connector.
- Loose or poor contact of the angle sensor connector.

### 10. Suspension Level Relays Inspection

Check the suspension level relays and their circuits (page 14-29).

***Does the suspension level relays and circuit check OK?***

**NO** –

- Faulty suspension level relay(s).
- Open circuit in the wire harness.
- Loose or poor contact of the related connectors.

**YES** – GO TO STEP 11.



**11. Suspension Level Relay Control Line Inspection**

Turn the ignition switch to "ON" or "ACC."  
 Measure the voltage between the following wire terminal (+) of the meter 20P black connector and ground (-).

- Red
- Green/red
- Green/yellow

There should be battery voltage.

**Is battery voltage present?**

- NO** - • Open or short circuit in the wire harness between the combination meter and suspension level relays.  
 • Loose or poor contact of the related connectors.
- YES** - Faulty combination meter; replace the meter/gauge assembly (page 20-17).

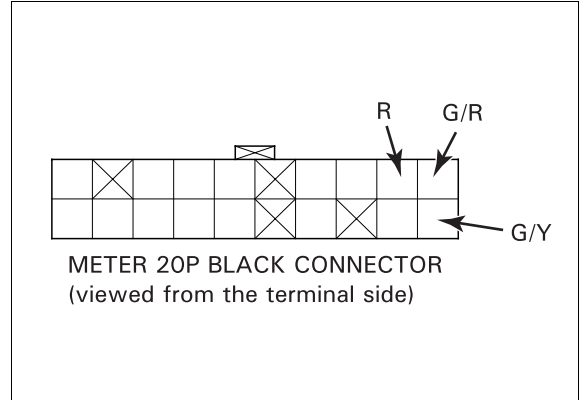

**12. Actuator Motor Operation Inspection at Actuator Motor**

Remove the right saddlebag (page 2-15).  
 Disconnect the actuator motor connector.  
 Check the actuator motor operation by connecting the fully charged 12-V battery.

- If the angle sensor resistance is 2.5 kΩ or more:  
 Connect the battery positive (+) terminal to the Light green/red wire terminal of the actuator motor connector and the battery negative (-) terminal to the Green wire terminal within 3 seconds (max. 3 seconds).
- If the angle sensor resistance is 2.5 kΩ or less:  
 Connect the battery positive (+) terminal to the Green wire terminal of the actuator motor connector and the battery negative (-) terminal to the Light green/red wire terminal within 3 seconds (max. 3 seconds).



**Does the actuator motor operate when connected as described above?**

- NO** - Faulty actuator motor; replace the shock absorber assembly (page 14-16).
- YES** - Open circuit in the Brown/white and Green wires between the suspension level relays and actuator motor connector.

## REAR WHEEL/SUSPENSION

**Suspension level cannot be memorized with the memory switch**

### 1. Memory Switch 1 and 2 Operation Inspection

Remove the left fairing pocket (page 2-11).  
Disconnect the panel switch 14P gray connector.  
Check for continuity between the wire terminals of the switch side connector in either MEMO 1 or MEMO 2 switch positions. Continuity should exist between the color coded wires as follows:

#### MEMO 1 SWITCH

Position \ Color	Br/Y	G/Y
	PUSH	○ — ○
FREE		

#### MEMO 2 SWITCH

Position \ Color	Br/Bu	G/Y
	PUSH	○ — ○
FREE		

**Is there continuity between the wires as shown in the charts?**

- NO** – Faulty memory switch; replace the panel switch assembly (page 20-32).  
**YES** – GO TO STEP 2.

### 2. Memory Switch 1 and 2 Control Line Short Circuit inspection

Remove the combination meter (page 20-17).  
Check the following wires for continuity to ground at the panel switch 14P gray connector.

- Brown/yellow
- Brown/blue

**Is there continuity?**

- YES** – Short circuit in the fairing sub-wire harness.  
**NO** – GO TO STEP 3.

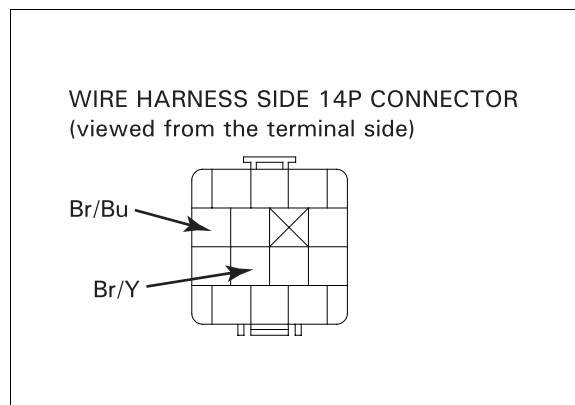
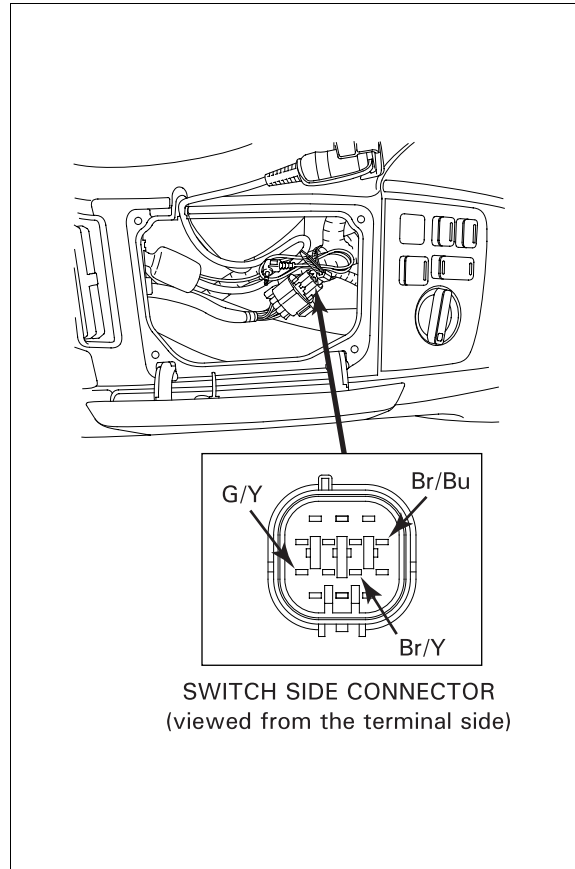

### 3. Memory Switch 1 and 2 Control Line Continuity inspection

Check the following wires for continuity between the panel switch 14P gray connector and combination meter 16P black connector.

- Brown/yellow
- Brown/blue

#### ***Is there continuity?***

**NO** - Open circuit in the fairing sub-wire harness.

**YES** -

- Loose or poor contact of the switch 14P gray connector and meter 16P black connector.
- Faulty combination meter; replace the meter/gauge assembly (page 20-19).

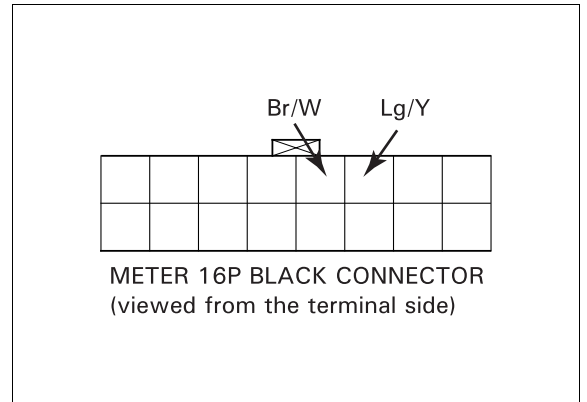

## REAR WHEEL/SUSPENSION

### REAR WHEEL

#### REAR WHEEL REMOVAL

Remove rear fender A (page 2-13).

Set the rear wheel on the ground and loosen the five rear axle nuts while applying the rear brake. Put the motorcycle on its center stand and support the motorcycle securely.

Remove the five rear wheel nuts.

Move the rear wheel to the left to separate it from the final gear case and remove the rear wheel.

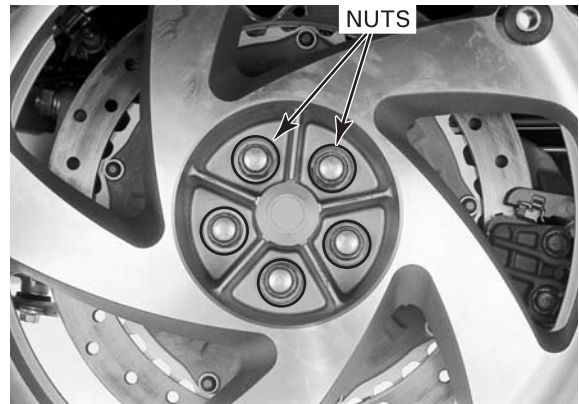

#### REAR BRAKE DISC REPLACEMENT

Remove the rear wheel (page 14-14).

Remove the following:

- bolt and brake hose clamp
- two bolts and brake caliper
- two screws (using an impact driver)
- brake disc
- ABS model only: six bolts and pulser ring if necessary

*ABS model:* Install a new pulser ring with new bolts and tighten them.

**TORQUE: 8 N·m (0.8 kgf·m, 5.8 lbf·ft)**

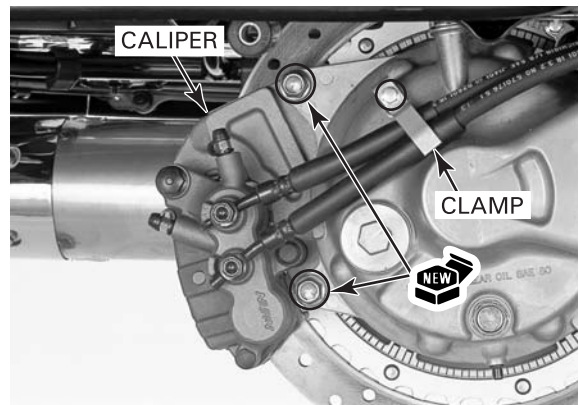

Clean the mating surfaces of the final drive assembly and brake disc, and make sure that no foreign materials are allowed.

Install a new brake disc onto the stud bolts. Install new screws and tighten them.

**TORQUE: 9 N·m (0.9 kgf·m, 6.5 lbf·ft)**

Install the brake caliper with new bolts and tighten them.

**TORQUE: 45 N·m (4.6 kgf·m, 33 lbf·ft)**



Install the brake hose clamp onto the gear case and tighten the bolt.

**TORQUE: 12 N·m (1.2 kgf·m, 9 lbf·ft)**

For rear wheel installation, see page 14-14.

*ABS model:* After installing the rear wheel, check the rear wheel speed sensor air gap (page 16-29).

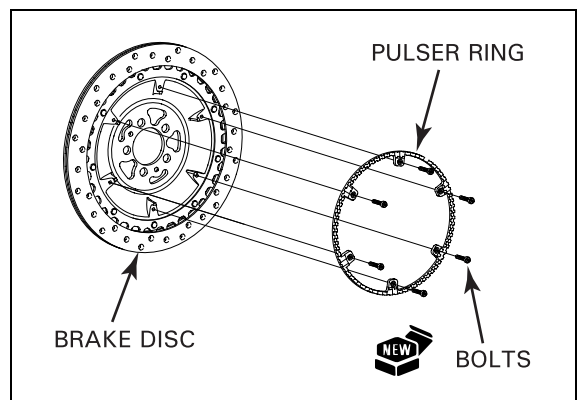

**WHEEL RIM INSPECTION**

Remove the axle cap from the rear wheel. Check the rim runout by placing the wheel in a truing stand. Spin the wheel slowly and read the runout using a dial indicator. Actual runout is 1/2 the total indicator reading.

**SERVICE LIMITS: Radial: 2.0 mm (0.08 in)  
Axial: 2.0 mm (0.08 in)**

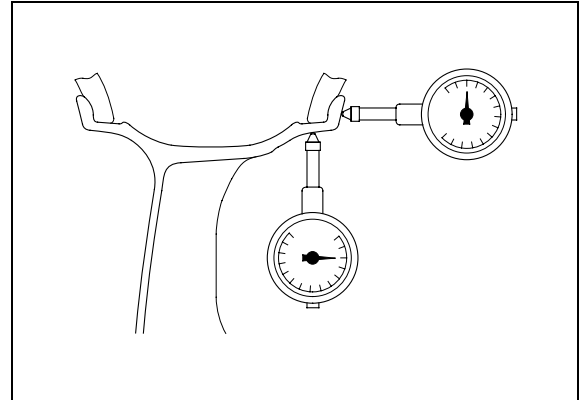

**WHEEL BALANCE**

NOTE:

*Wheel balance directly affects the stability, handling and overall safety of the motorcycle. Carefully check balance before reinstalling the wheel.*

- Mount the tire with the arrow facing in the normal direction of rotation.
- The wheel balance must be checked when the tire is remounted.
- For optimum balance, the tire balance mark (a paint dot on the side wall) must be located next to the valve stem. Remount the tire if necessary.

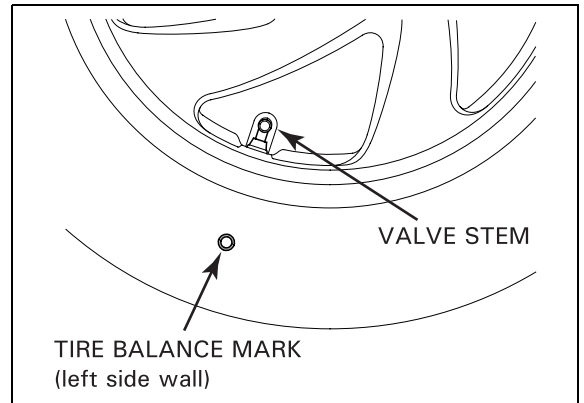

Mount the wheel and tire assembly on an inspection stand. Spin the wheel, allow it to stop, and mark the lowest (heaviest) part of the wheel with chalk. Do this two or three times to verify the heaviest area. If the wheel is balanced, it will not stop consistently in the same position.

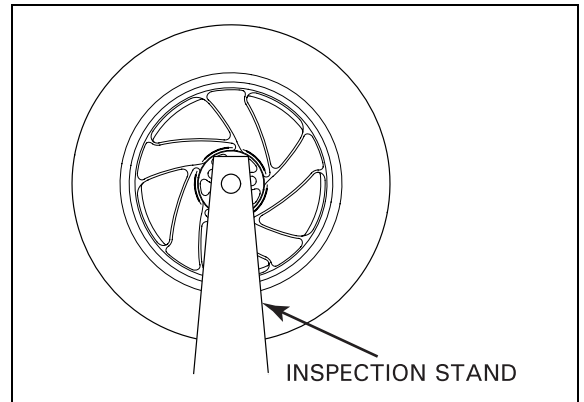

To balance the wheel, install a balance weight on the lightest side of the spoke, the side opposite the chalk marks. Add just enough weight so the wheel will no longer stop in the same position when it is spun. Do not add more than 70 g (2.5 oz) to the rear wheel. Install the axle cap.

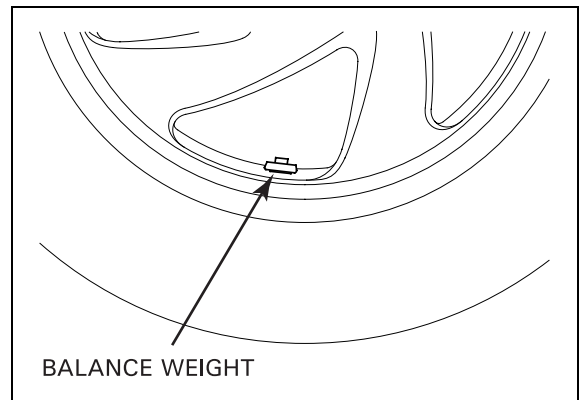

## REAR WHEEL/SUSPENSION

### REAR WHEEL INSTALLATION

Check the wheel bolt holes for wear, cracks or other damage.

Clean the mating surfaces of the rear wheel and brake disc, and remove any foreign material.

Install the rear wheel by aligning the bolt holes in the rear wheel with the stud bolts of the final drive assembly.

Install five wheel nuts and temporarily tighten them.

Place the motorcycle on its side stand so the rear wheel touches the ground.

Tighten the five axle nuts to the specified torque while applying the rear brake.

**TORQUE: 108 N·m (11.0 kgf·m, 80 lbf·ft)**

Perform the air gap inspection if the rear brake disc was removed (page 16-29).

Install rear fender A (page 2-6).

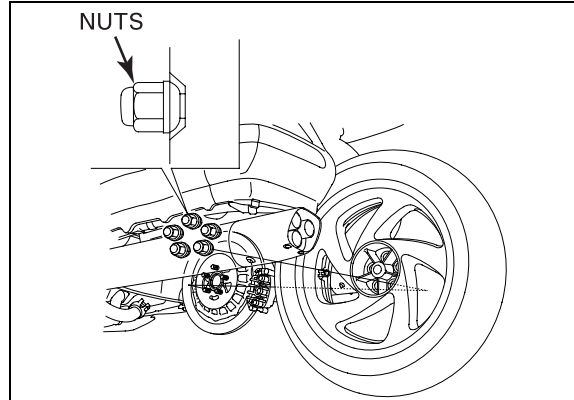

## SHOCK ABSORBER

### REMOVAL

Remove the right saddlebag (page 2-17).

Remove the fuel tank (page 5-56).

Remove the rear wheel (page 14-14).

Disconnect the angle sensor connectors from the suspension level actuator and disconnect the control motor connector.

Release the control motor connector from the clamp.

Remove the three mounting bolts and suspension level actuator from the frame.

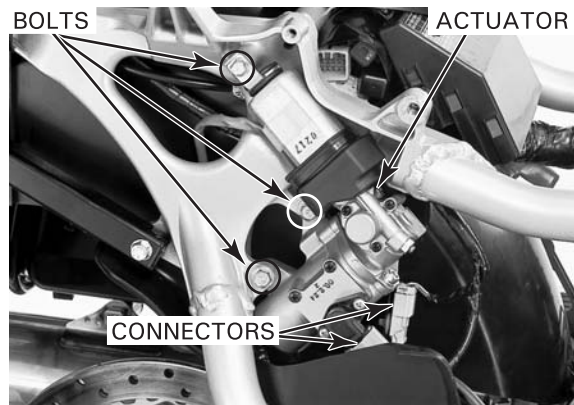

Remove the shock absorber lower mounting nut and bolt.

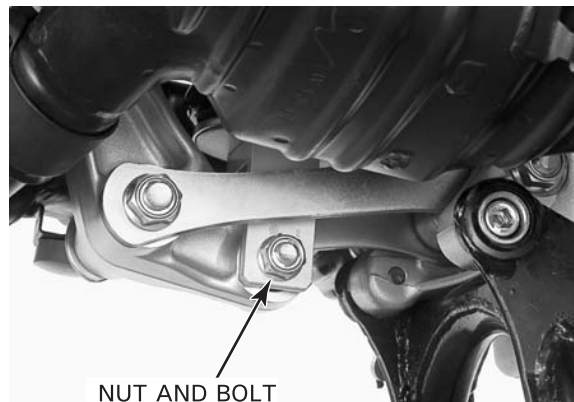



Remove the shock absorber upper mounting nut and bolt.  
Release the actuator hose from the clamp.  
Remove the shock absorber assembly.

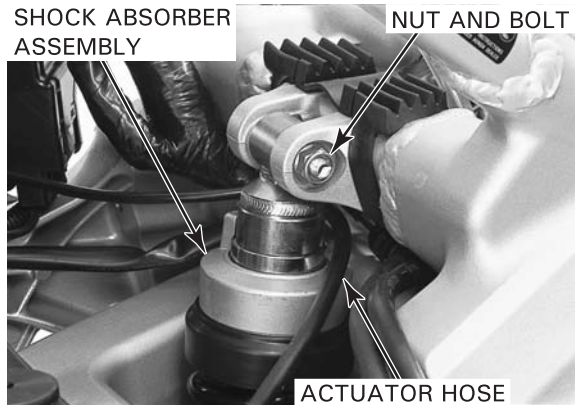

### INSPECTION

Check the damper unit for leakage or other damage.  
Check the upper joint bushing and damper rubber for wear or damage.  
Inspect the actuator hose and fittings for loose connections, deterioration, cracks, damage or signs of leakage.

If necessary, replace the shock absorber as an assembly.



### DISPOSAL

Center punch the damper case to mark the drilling point.

#### DRILLING POINT:

**40 mm (1.6 in) from the center of the upper eyelet as shown**

Wrap the shock absorber inside a plastic bag.  
Support the shock absorber upright in a vise as shown.  
Through the open end of the bag, insert a drill motor with a sharp 2 – 3 mm (5/64 – 1/8 in) drill bit.

#### NOTICE

- Do not use a dull drill bit which could cause a build-up of excessive heat and pressure inside the damper, leading to an explosion and severe injury.
- The shock absorber contains nitrogen gas and oil under high pressure. Do not drill any further down the damper case than the measurement given above, or you may drill into the oil chamber. Then high pressure oil may cause serious injury.
- Always wear eye protection to avoid getting metal shavings in your eyes when the gas pressure is released. The plastic bag is only intended to shield you from the escaping gas.

Hold the bag around the drill motor and briefly run the drill motor inside the bag; this will inflate the bag with air from the motor and help keep the bag from the getting caught in the drill bit when you start drilling into the shock.

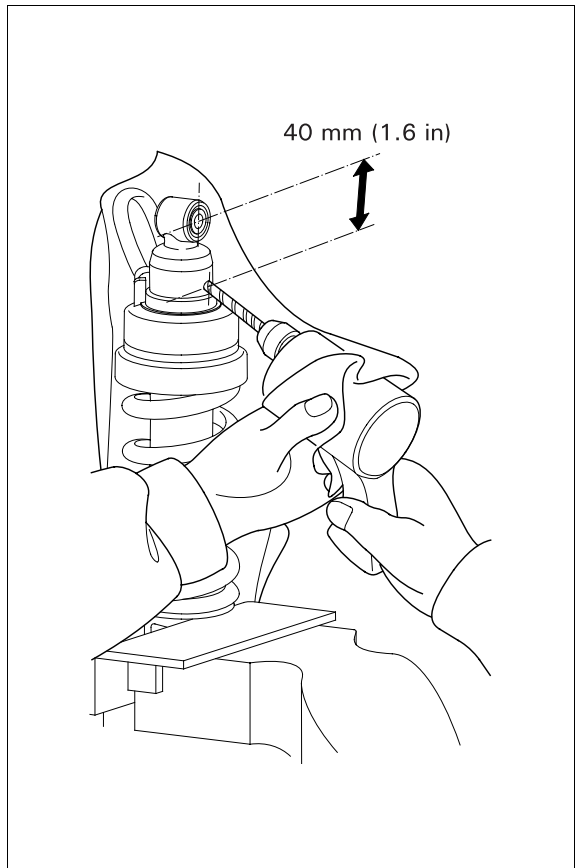

## REAR WHEEL/SUSPENSION

### INSTALLATION

*Route the wires and hose properly (page 1-23).*

Install the shock absorber assembly in the frame by inserting the upper mounting bolt from the left side. Install the upper mounting nut.

Securely clamp the actuator hose with the clamp.

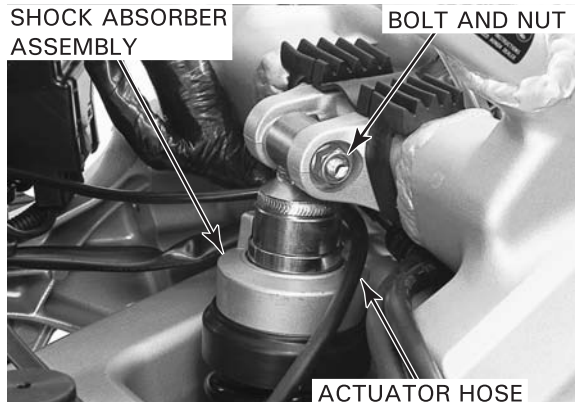

Install the lower mounting bolt from the left side. Install the lower mounting nut. Tighten the shock absorber upper and lower mounting nuts to the specified torque.

**TORQUE: 42 N·m (4.3 kgf·m, 31 lbf·ft)**

Install the suspension level actuator with the three mounting bolts.

Tighten the mounting bolt and the two 8-mm bolts to the specified torque.

**TORQUE: 26 N·m (2.7 kgf·m, 20 lbf·ft)**

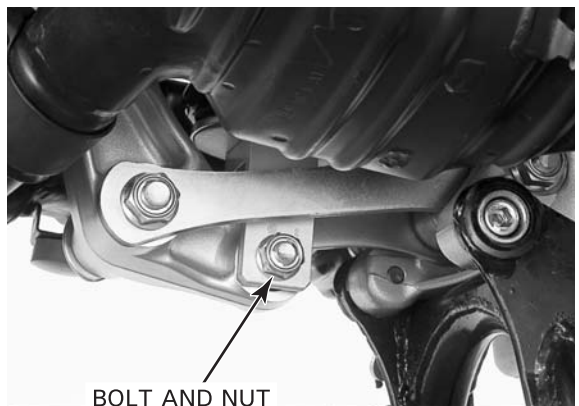

Connect the angle sensor connector to the suspension level actuator and connect the control motor connector. Clamp the control motor connector onto the clamp.

Install the rear wheel (page 14-14).

Install the fuel tank (page 5-56).

Install the right saddlebag (page 2-15).

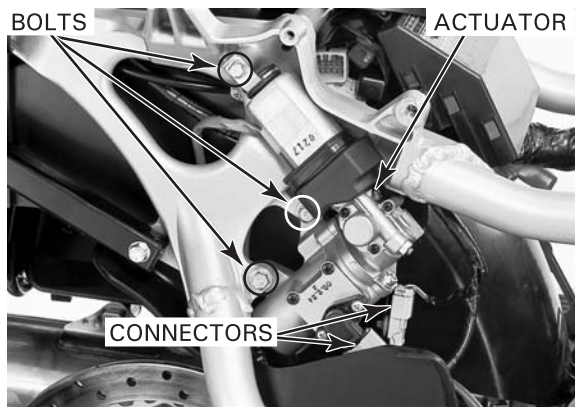

## SUSPENSION LINKAGE

### SHOCK ARM REMOVAL

Remove the exhaust system (page 2-18).

Remove the rear wheel (page 14-14).

Remove the shock absorber lower mounting nut and bolt.

Remove the shock arm-to-swingarm nut and bolt.

Remove the shock arm-to-shock link nut and bolt.

Remove the shock arm.



Remove the pivot collars and dust seals from the shock arm.

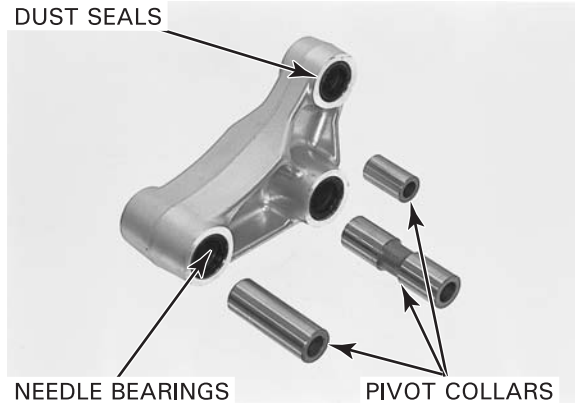

**SHOCK ARM INSPECTION**

Check the dust seals and collars for wear, damage or fatigue.

Check the needle bearings for damage or loose fit.

If the needle bearings are damaged, replace them (page 14-19).

**SHOCK ARM NEEDLE BEARING REPLACEMENT**

**SWINGARM AND SHOCK LINK SIDE:**

Remove the needle bearings from the shock arm pivot using the special tools.

**TOOLS:**

- |                            |   |
|----------------------------|---|
| <b>Bearing remover set</b> | <b>07936-371001</b><br>(not available in U.S.A.)              |
| - remover weight           | 07741-0010201 or 07936-371020A or 07936-3710200 (U.S.A. only) |
| - remover handle           | 07936-3710100   |
| - remover, 20 mm           | 07936-3710600   |



**SHOCK ABSORBER SIDE:**

Remove the needle bearing from the shock arm pivot using the special tools and a hydraulic press.

**TOOLS:**

- |                               |                      |
|-------------------------------|----------------------|
| <b>Driver</b>                 | <b>07949-3710001</b> |
| <b>Attachment, 22 x 24 mm</b> | <b>07746-0010800</b> |
| <b>Pilot, 17 mm</b>           | <b>07746-0040400</b> |

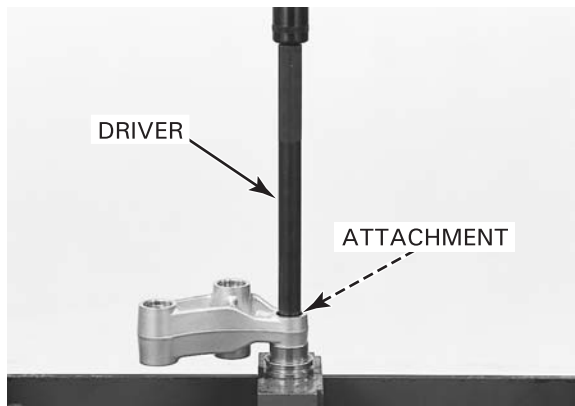

Apply grease to the needle rollers of new bearings. Carefully press the needle bearing in the shock arm pivot until the depth from the shock arm outer surface is at specification, using the special tools and a hydraulic press.

**SPECIFIED DEPTH:**

- Swingarm side: 5.5 – 6.0 mm (0.22 – 0.24 in)**
- Shock link side: 5.5 – 6.0 mm (0.22 – 0.24 in)**
- Shock absorber side: 5.3 – 5.7 mm (0.21 – 0.22 in)**

**TOOLS:**

- |   |                      |
|---|----------------------|
| <b>Swingarm side and shock link side:</b> |                      |
| <b>Driver</b>                             | <b>07749-0010000</b> |
| <b>Attachment, 24 x 26 mm</b>             | <b>07746-0010700</b> |
| <b>Pilot, 20 mm</b>                       | <b>07746-0040500</b> |

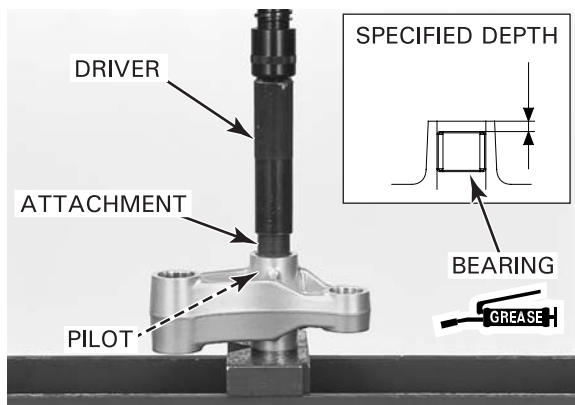

## REAR WHEEL/SUSPENSION

### Shock absorber side:

Driver	07749-0010000
Attachment, 24 x 26 mm	07746-0010700
Pilot, 17 mm	07746-0040400

### SHOCK ARM INSTALLATION

Apply grease to new dust seal lips and install them into the shock arm pivots until they are fully seated.

Install the pivot collars into the shock arm pivots.

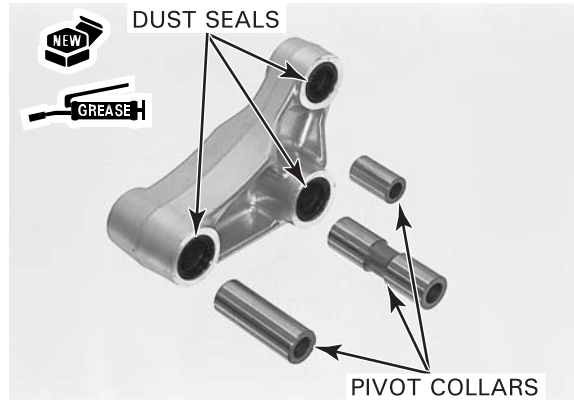

Install the shock arm onto the frame by inserting the mounting bolts from the left side. Install the mounting nuts and tighten the nuts to the specified torque.

#### TORQUE:

- Shock absorber lower mounting nut:  
42 N·m (4.3 kgf·m, 31 lbf·ft)
- Shock arm-to-swingarm nut:  
64 N·m (6.5 kgf·m, 47 lbf·ft)
- Shock arm-to-shock link nut:  
64 N·m (6.5 kgf·m, 47 lbf·ft)

Install the rear wheel (page 14-16).  
Install the exhaust system (page 2-20).

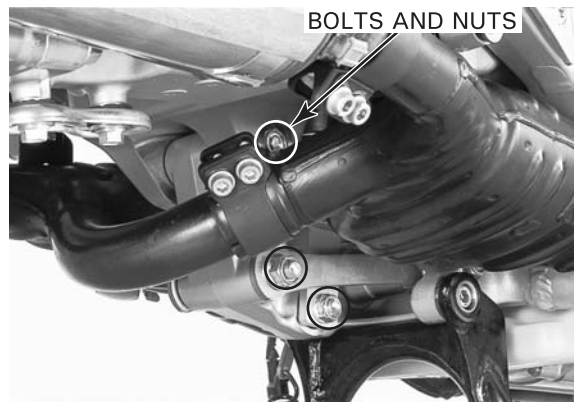

### SHOCK LINK REMOVAL

Remove the exhaust system (page 2-18).  
Remove the rear wheel (page 14-14).

Remove the shock arm-to-shock link nut and bolt.  
Remove the shock link-to-frame nut and bolt.  
Remove the shock link.

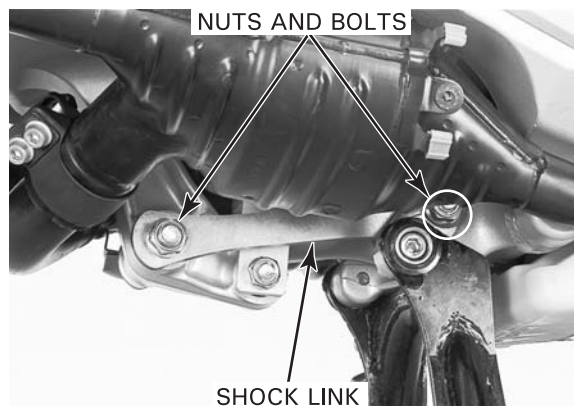

Remove the pivot collar and dust seals from the shock link.

**SHOCK LINK INSPECTION**

Check the dust seals and collar for wear, damage or fatigue.

Check the needle bearings for damage or loose fit.

If the needle bearings are damaged, replace them (page 14-21).

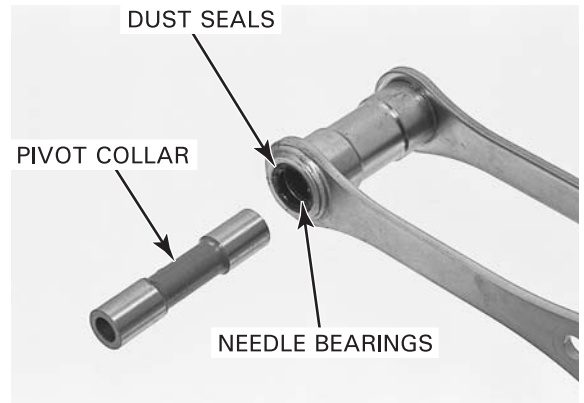

**SHOCK LINK NEEDLE BEARING REPLACEMENT**

Remove the needle bearings from the shock arm pivot using the special tools.

**TOOLS:**

**Bearing remover set**

- remover weight

- remover handle

- remover, 20 mm

**07936-371001**  
(not available in U.S.A.)  
**07741-0010201** or  
**07936-371020A** or  
**07936-3710200**  
(U.S.A. only)  
**07936-3710100**  
**07936-3710600**

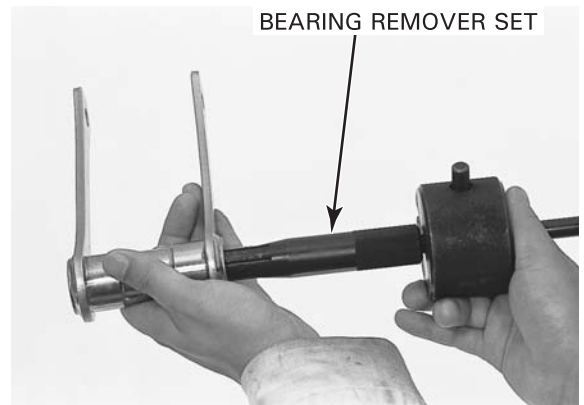

Apply grease to the needle rollers of new bearings. Carefully press the needle bearings into the shock link pivot until the depth from the shock link outer surface is at specification, using the special tools and a hydraulic press.

**SPECIFIED DEPTH: 5.5 – 6.0 mm (0.22 – 0.24 in)**

**TOOLS:**

**Driver**  
**Attachment, 24 x 26 mm**  
**Pilot, 20 mm**

**07749-0010000**  
**07746-0010700**  
**07746-0040500**

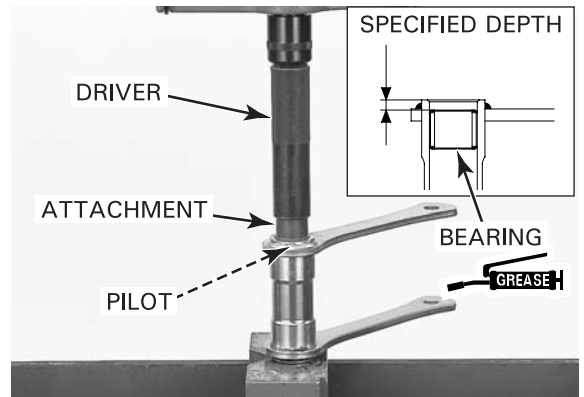

**SHOCK LINK INSTALLATION**

Apply grease to new dust seal lips and install them into the shock link pivot until they are fully seated.

Install the pivot collar into the shock link pivot.

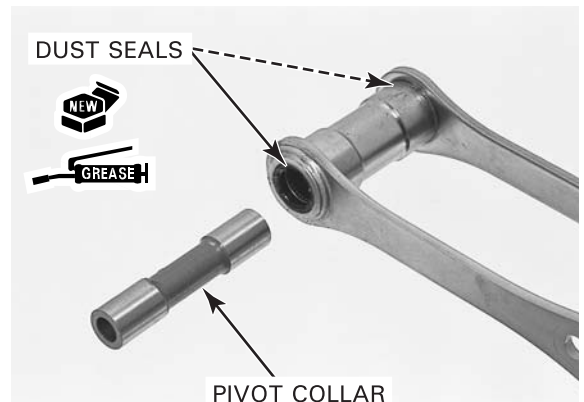



## REAR WHEEL/SUSPENSION

Install the shock link onto the frame by inserting the mounting bolts from the left side.  
Install the mounting nuts and tighten the nuts to the specified torque.

### TORQUE:

**Shock arm-to-frame nut:**

**64 N·m (6.5 kgf·m, 47 lbf·ft)**

**Shock arm-to-shock link nut:**

**64 N·m (6.5 kgf·m, 47 lbf·ft)**

Install the rear wheel (page 14-16).  
Install the exhaust system (page 2-20).

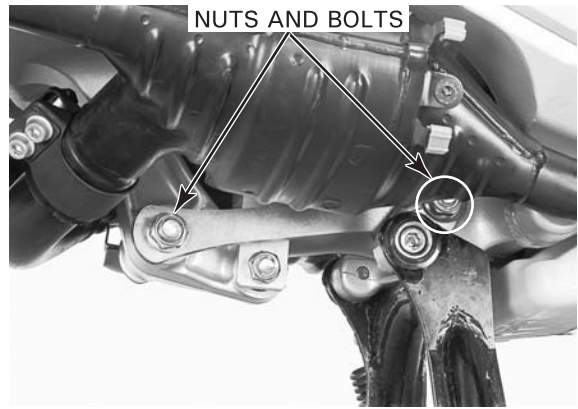

## SWINGARM

### REMOVAL

Remove the final gear case (page 12-10).  
Remove the shock absorber (page 14-16).

Remove the mounting bolts and each swingarm pivot bolt cover.

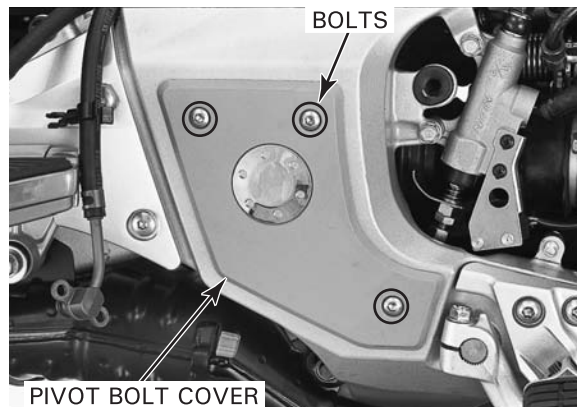

Remove the bolt and brake pipe clamp.

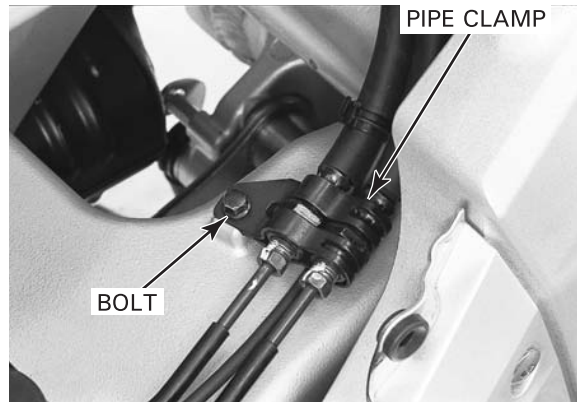

Remove the left pivot lock nut with the special tool.

### TOOL:

**Lock nut wrench, 10 x 44/6 x 46 mm**

**07ZMA-MCAA101**

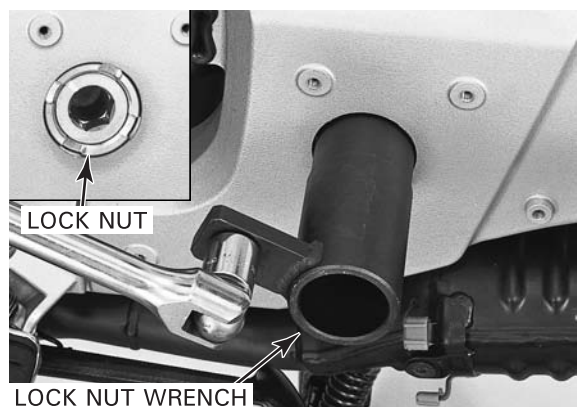



## REAR WHEEL/SUSPENSION

Remove the left pivot bolt.

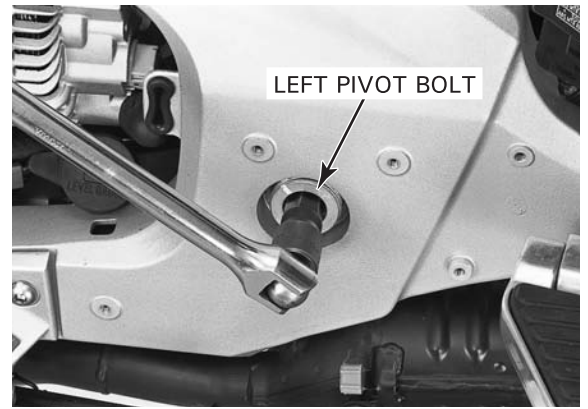

Remove the right pivot bolt.

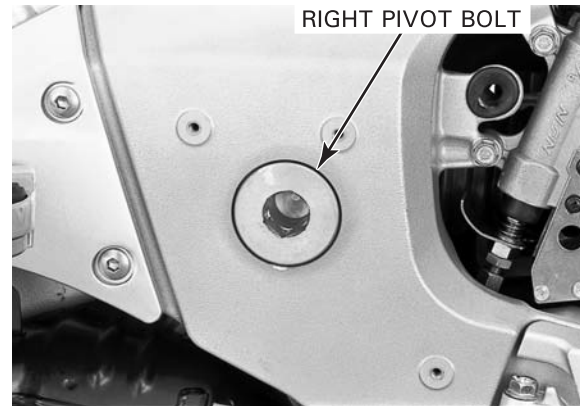

Remove the shock arm-to-shock link nut and bolt.

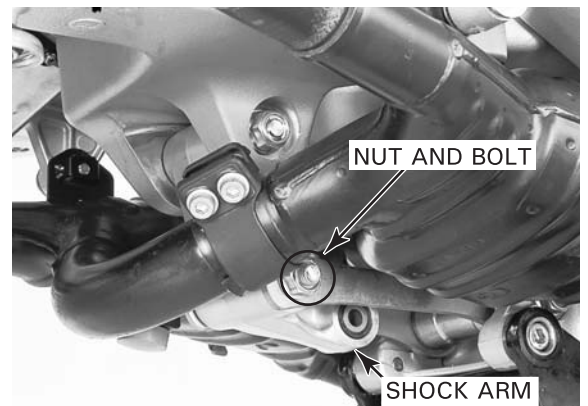

Remove the two screws and brake light/cruise cancel switch assembly from the rear master cylinder.

Remove the joint boot off the engine.  
Separate the drive shaft from the output shaft of the engine, then remove the swingarm.

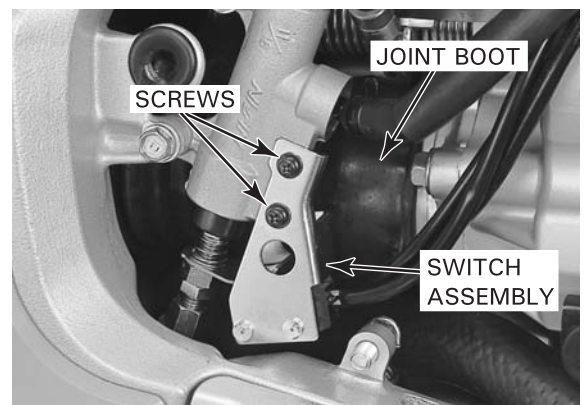

## REAR WHEEL/SUSPENSION

Remove the joint boot.  
Check the joint boot for tears or other damage and replace it if necessary.



Remove the drive shaft from the swingarm.

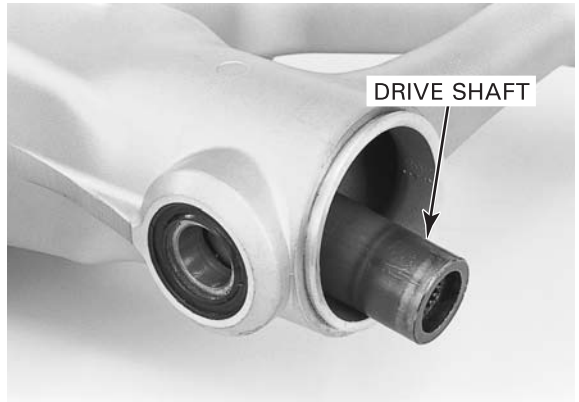

Remove the shock arm-to-swingarm nut and bolt and shock arm from the swingarm.

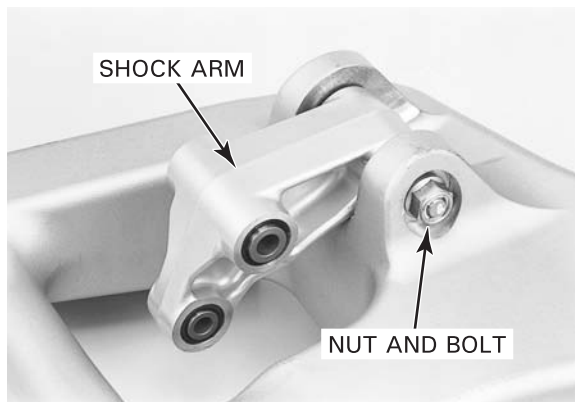

### INSPECTION

*Both bearings, outer races and grease holders must be replaced as a set if any part is damaged or worn.*

Remove the tapered roller bearings from the swing-arm pivots.

Check the bearings and dust seals for damage or wear.

Check the outer races for damage or wear.

Check the grease holders for damage or deformation.

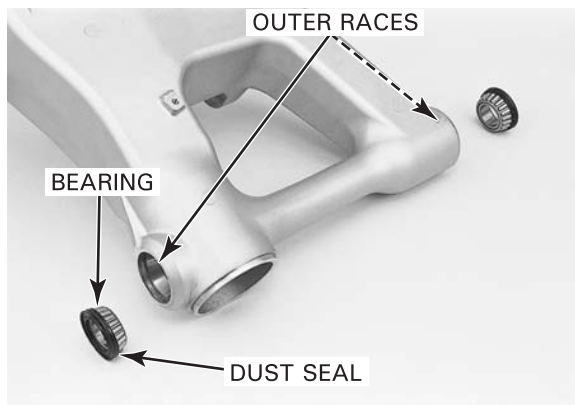

Check that the universal joint moves smoothly without binding or noise.

Check the splines for wear or damage.

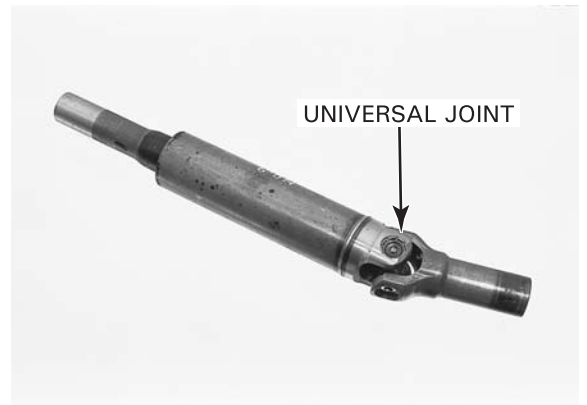

### PIVOT BEARING OUTER RACE REPLACEMENT

Punch or drill a 1/2 inch hole into the grease holder of the bearing race.

Insert the threaded end of the slide hammer into the hole and attach the special tools as shown.

Remove the outer race and grease holder with the installed tools.

**TOOLS:**

<b>Attachment, 32 x 35 mm</b>	<b>07746-0010100</b>
<b>Slide hammer, 3/8" x 16 mm thread</b>	<b>Equivalent commercially available in U.S.A.</b>

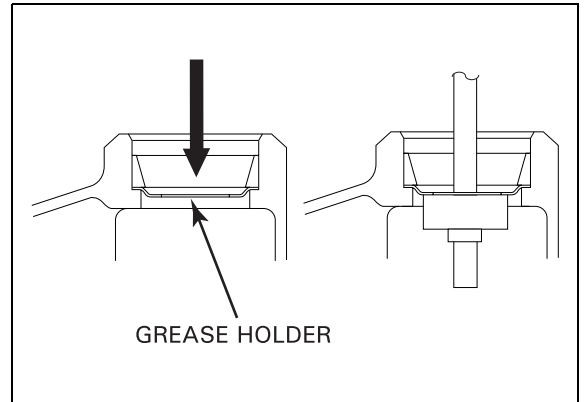

Insert a suitable driver through the swingarm and drive out the other side grease holder and bearing using a suitable hydraulic press.

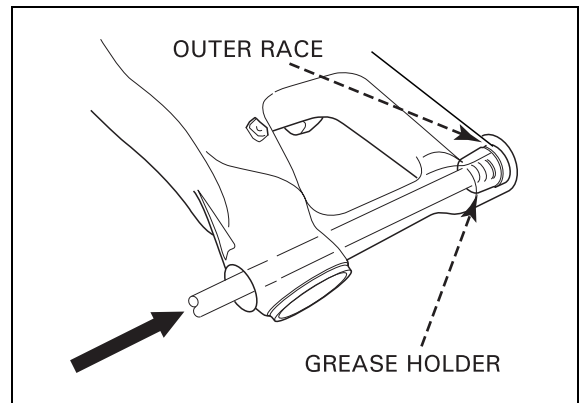

Install the new grease holders into the swingarm pivot.

Carefully press the new outer races into the swingarm pivots until they are fully seated, using the special tools and a hydraulic press.

**TOOLS:**

<b>Driver</b>	<b>07749-0010000</b>
<b>Attachment, 42 x 47 mm</b>	<b>07746-0010300</b>

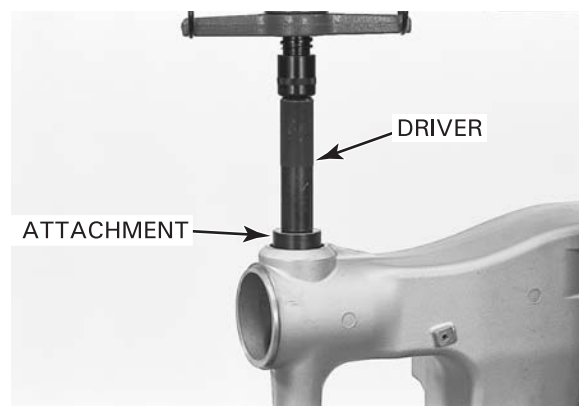

## REAR WHEEL/SUSPENSION

Apply grease to the tapered needle rollers and dust seals lips of new bearings and install them into the swingarm pivots.

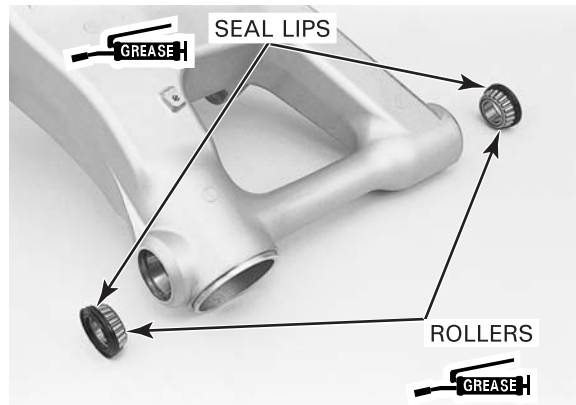

### INSTALLATION

Install the shock arm onto the swingarm by inserting the mounting bolt. Install the shock arm-to-swingarm nut and tighten the nut to the specified torque.

**TORQUE: 64 N·m (6.5 kgf·m, 47 lbf·ft)**

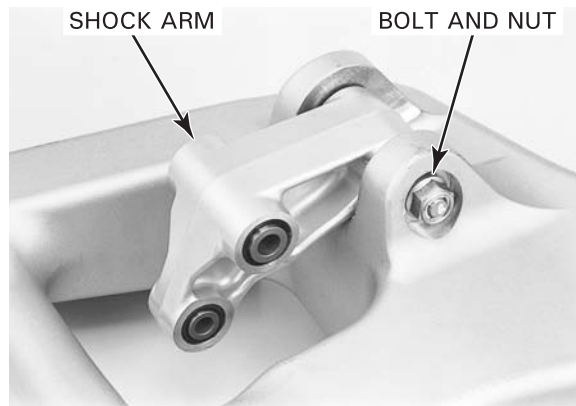

Apply 1 g (0.04 oz) of molybdenum disulfide grease to the output shaft side splines of the drive shaft.

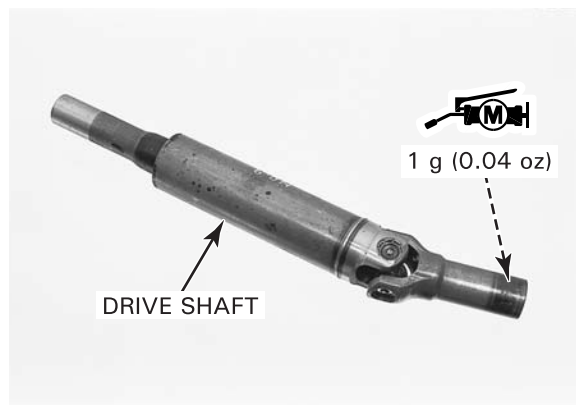

Place the drive shaft into the swingarm with the short shaft facing the front of the motorcycle.

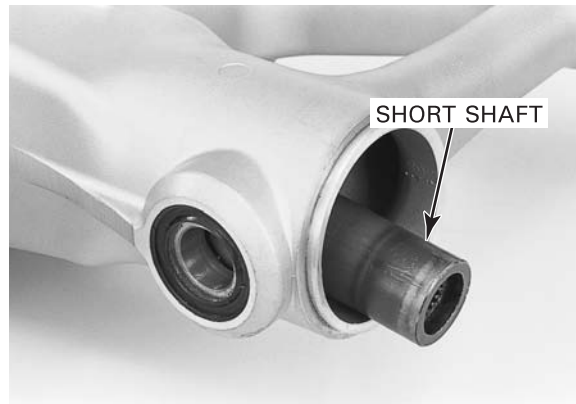

Install the joint boot onto the swingarm with one joint boot tab facing up vertically as shown.

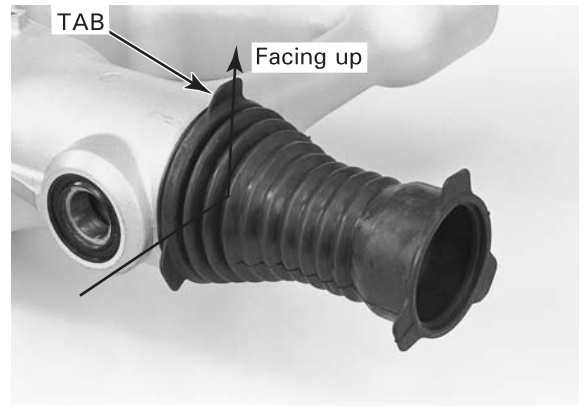

Remove the joint shaft from the final gear case (page 12-10) and temporarily install it into the drive shaft to ease installation of the drive shaft.

*Route the wires, hoses and pipes properly (page 1-23).*

Set the swingarm into the frame and engage the splines of the drive and output shafts securely.

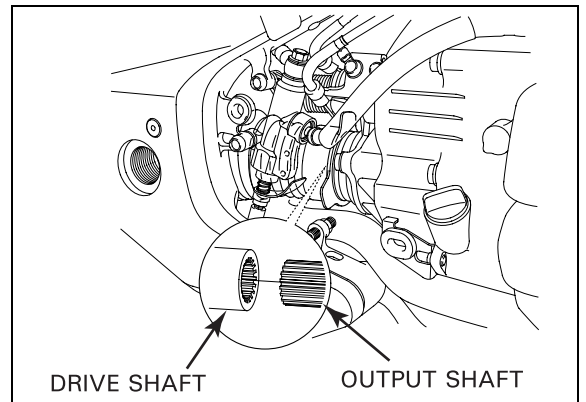

Align the frame pivot bolt hole with the swingarm securely. Install and tighten the right pivot bolt to the specified torque.

**TORQUE: 108 N·m (11.0 kgf·m, 80 lbf·ft)**

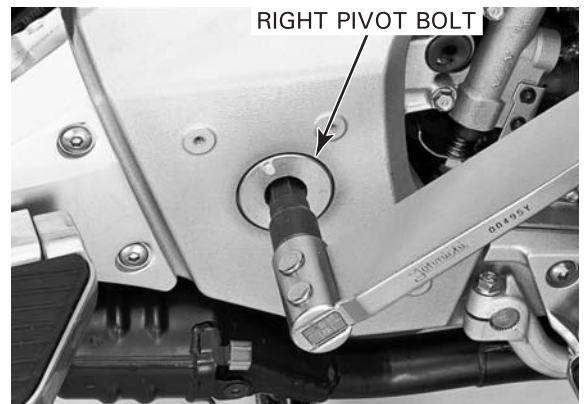

Align the frame pivot bolt hole with the swingarm securely. Install and tighten the left pivot bolt to the specified torque.

**TORQUE: 34 N·m (3.5 kgf·m, 25 lbf·ft)**

Move the swingarm up and down several times to seat the pivot bearings.

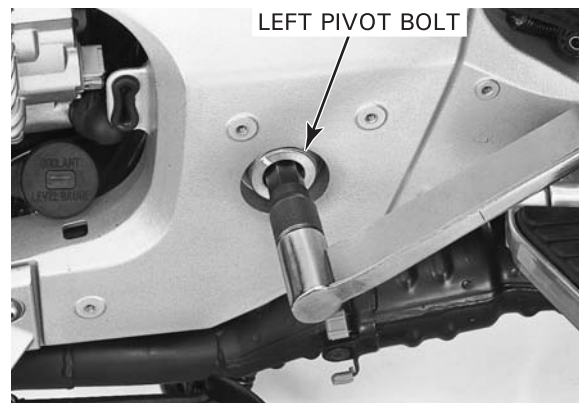



## REAR WHEEL/SUSPENSION

Retighten the right pivot bolt to the same torque.

**TORQUE: 108 N·m (11.0 kgf·m, 80 lbf·ft)**

Install the left pivot lock nut.

*Refer to torque wrench reading information on page 14-3 "Service Information."*

Hold the left pivot bolt while tightening the left pivot lock nut to the specified torque.

**TOOL:**

**Lock nut wrench, 10 x 44/6 x 46 mm  
07ZMA-MCAA101**

**TORQUE: Actual: 108 N·m (11.0 kgf·m, 80 lbf·ft)**

**Indicated: 98 N·m (10.0 kgf·m, 72 lbf·ft)**

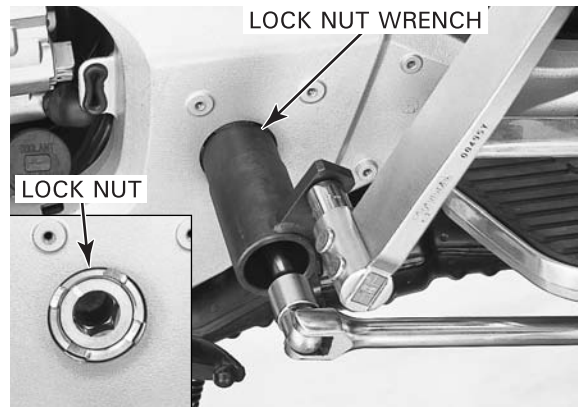

Insert the shock arm-to-shock link bolt from the left side through the shock link, shock arm and shock link.

Install the mounting nut and tighten the nut to the specified torque.

**TORQUE: 64 N·m (6.5 kgf·m, 47 lbf·ft)**

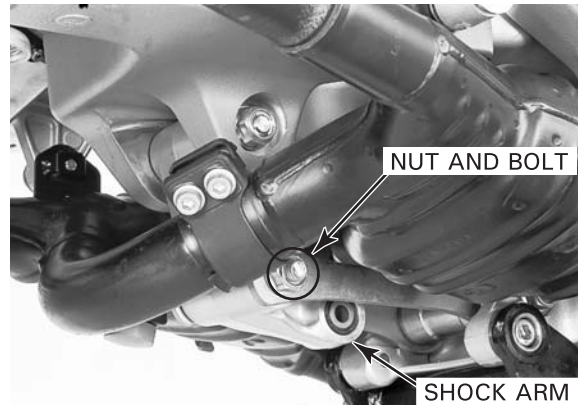

Install the joint boot over the engine securely.

Apply locking agent to the threads of the switch holder screws.

Install the brake light/cruise cancel switch assembly with the screws.

Adjust the switch position so that the brake light comes on when pushing the brake pedal slightly and the push rod moves 0.7 – 1.7 mm.

Tighten the holder screws.

**TORQUE: 2 N·m (0.2 kgf·m, 1.4 lbf·ft)**

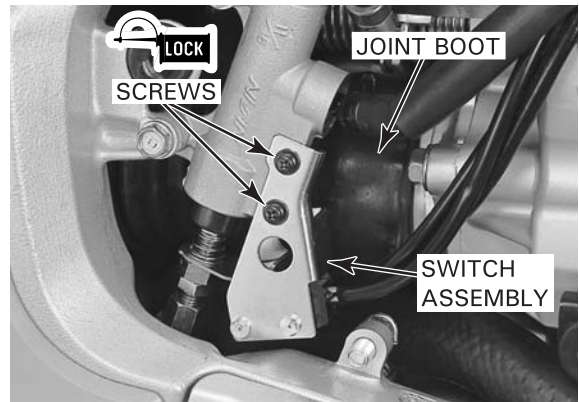

Install the brake pipe clamp with the bolt and tighten the bolt to the specified torque.

**TORQUE: 12 N·m (1.2 kgf·m, 9 lbf·ft)**

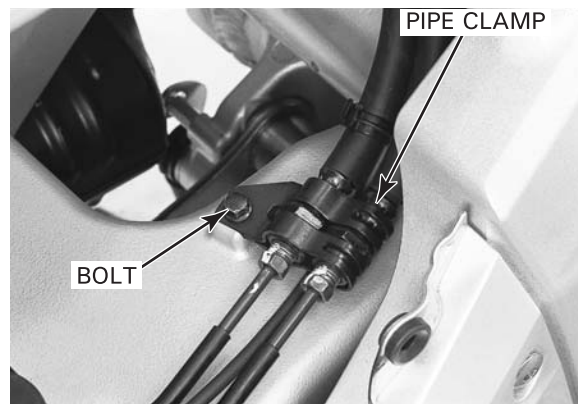



Install each swingarm pivot bolt cover.  
 Install and tighten the mounting bolts.  
 Install the final gear case (page 12-21).  
 Install the shock absorber (page 14-18).

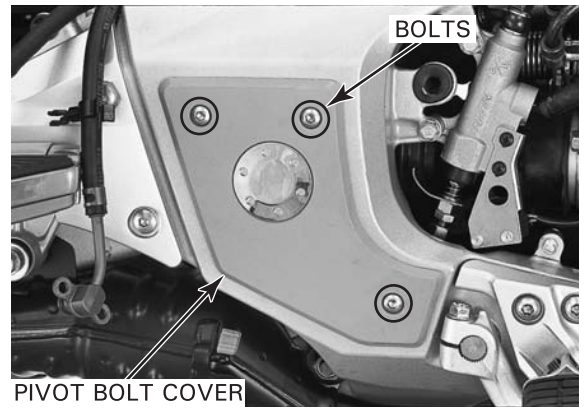

## SUSPENSION LEVEL RELAY

### SYSTEM INSPECTION

Check that the audio system and multi-display functions properly.  
 Shift the transmission into neutral and make sure the reverse system is off.

Remove the seat (page 2-5).

Remove the two screws and remove the relay box.  
 Remove the relay blocks from the relay box.

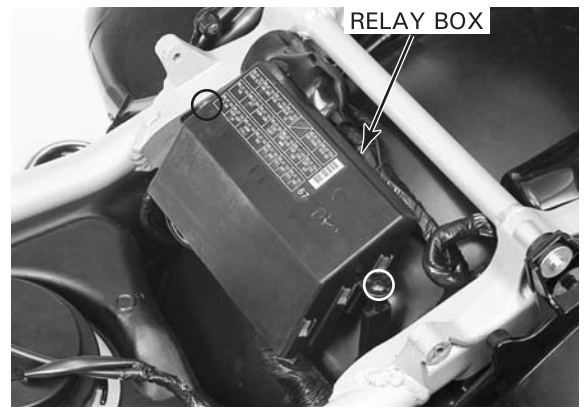

1. Turn the ignition switch to "OFF" and exchange the suspension level main relay with a known-good one.  
 Turn the ignition switch to "ON" or "ACC" and operate the manual height switch.
  - If the suspension level actuator operates, replace the suspension level main relay with a new one.
  - If the suspension level actuator does not operate, go to step 2.
2. Turn the ignition switch to "OFF", and exchange the suspension level UP relay with a known-good one.  
 Turn the ignition switch to "ON" or "ACC" and operate the manual height switch.
  - If the suspension level actuator operates, replace the suspension level UP relay with a new one and check again using the original suspension level main relay.
  - If the suspension level actuator does not operate, go to step 3.
3. Turn the ignition switch to "OFF", and exchange the suspension level DOWN relay a known-good one.  
 Turn the ignition switch to "ON" or "ACC" and operate the manual height switch.
  - If the suspension level actuator operates, replace the suspension level DOWN relay with a new one and check again using the original suspension level main relay and UP relay.
  - If the suspension level actuator does not operate, go to step 4.

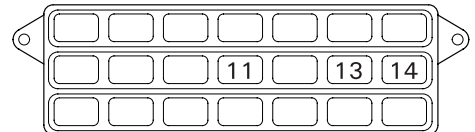

- 11. MAIN RELAY
- 13. UP RELAY
- 14. DOWN RELAY

## REAR WHEEL/SUSPENSION

4. Turn the ignition switch to "OFF" and remove the suspension level main relay. Measure the voltage between the Brown wire terminal (+) of the suspension level main relay connector and ground (-).

- If there is battery voltage, go to step 5.
- If there is no voltage, check for an open circuit in the Brown wire between the suspension level main relay and fuse box (No. 20 fuse).

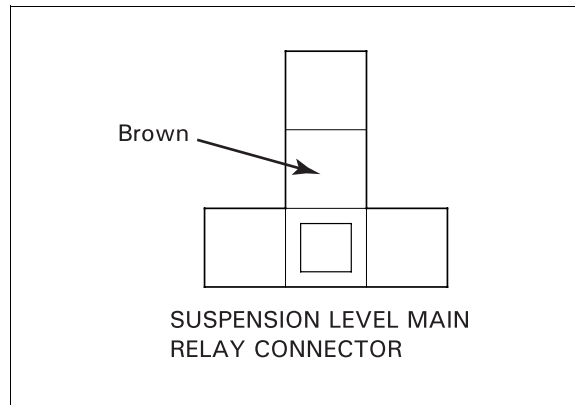

5. Turn the ignition switch to "ON" or "ACC." Measure the voltage between the Light green/black wire terminal (+) of each suspension level main relay connector and ground (-).

- If there is battery voltage, go to step 6.
- If there is no voltage, check for an open circuit in the Light green/black wire between the suspension level main relay and ACC relay.

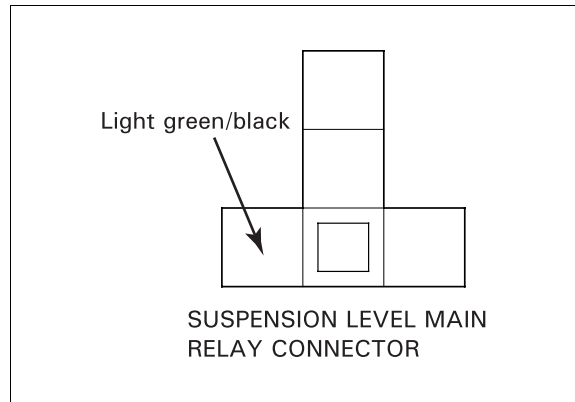

6. Turn the ignition switch to "OFF." Remove the suspension level UP and DOWN relays. Check the Red/black wires for continuity between the suspension level main relay and UP relay, and between the main relay and DOWN relay.

- If there is continuity, go to step 7.
- If there is no continuity, repair an open circuit in the Red/black wire.

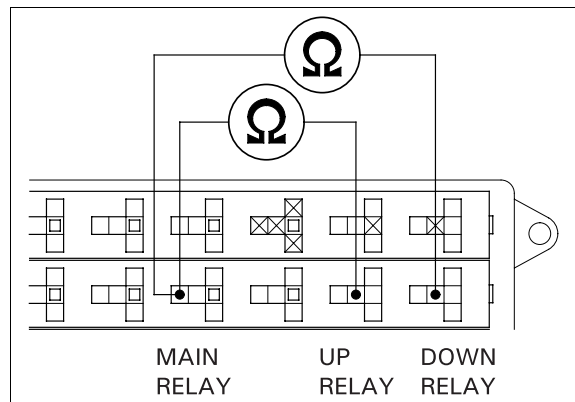

7. Check the actuator motor ground circuit for continuity between each Green wire terminal of the UP and DOWN relay connectors and ground.

- If there is continuity, go to step 8.
- If there is no continuity, repair an open circuit in the Green wire (actuator motor ground circuit).

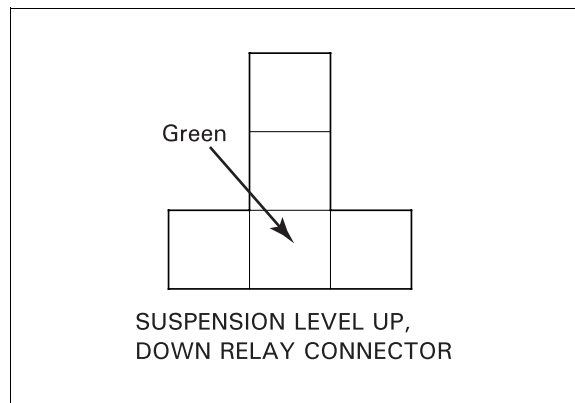

8. Turn the ignition switch to "ON" or "ACC."  
Measure the voltage between each Light green/black wire terminal (+) of the suspension level UP and DOWN relay connectors and ground (-).
- If there is battery voltage, follow the troubleshooting flow chart on (page 14-10).
  - If there is no voltage, check for an open circuit in the Light green/black wire between the suspension level UP and DOWN relay and ACC relay.

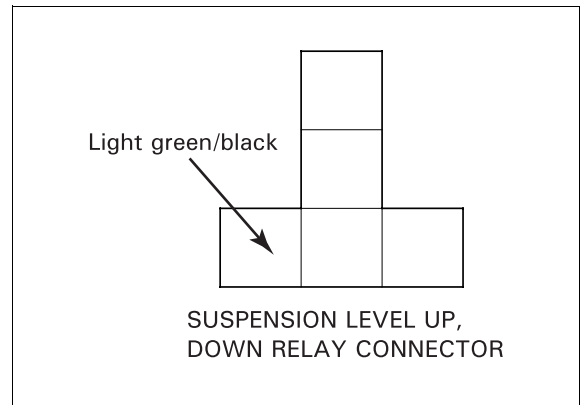

---

**MEMO**

---

# 15. BRAKE SYSTEM (Standard)

---

SYSTEM LOCATION.....	15-2	REAR MASTER CYLINDER/BRAKE PEDAL .....	15-19
SERVICE INFORMATION .....	15-3	SECONDARY MASTER CYLINDER .....	15-24
TROUBLESHOOTING .....	15-5	FRONT BRAKE CALIPER .....	15-27
BRAKE FLUID REPLACEMENT/AIR BLEEDING .....	15-6	REAR BRAKE CALIPER.....	15-34
BRAKE PAD/DISC.....	15-13	DELAY VALVE .....	15-38
FRONT MASTER CYLINDER.....	15-15	PROPORTIONAL CONTROL VALVE (PCV) .....	15-39

**BRAKE SYSTEM (Standard)**

**SYSTEM LOCATION**

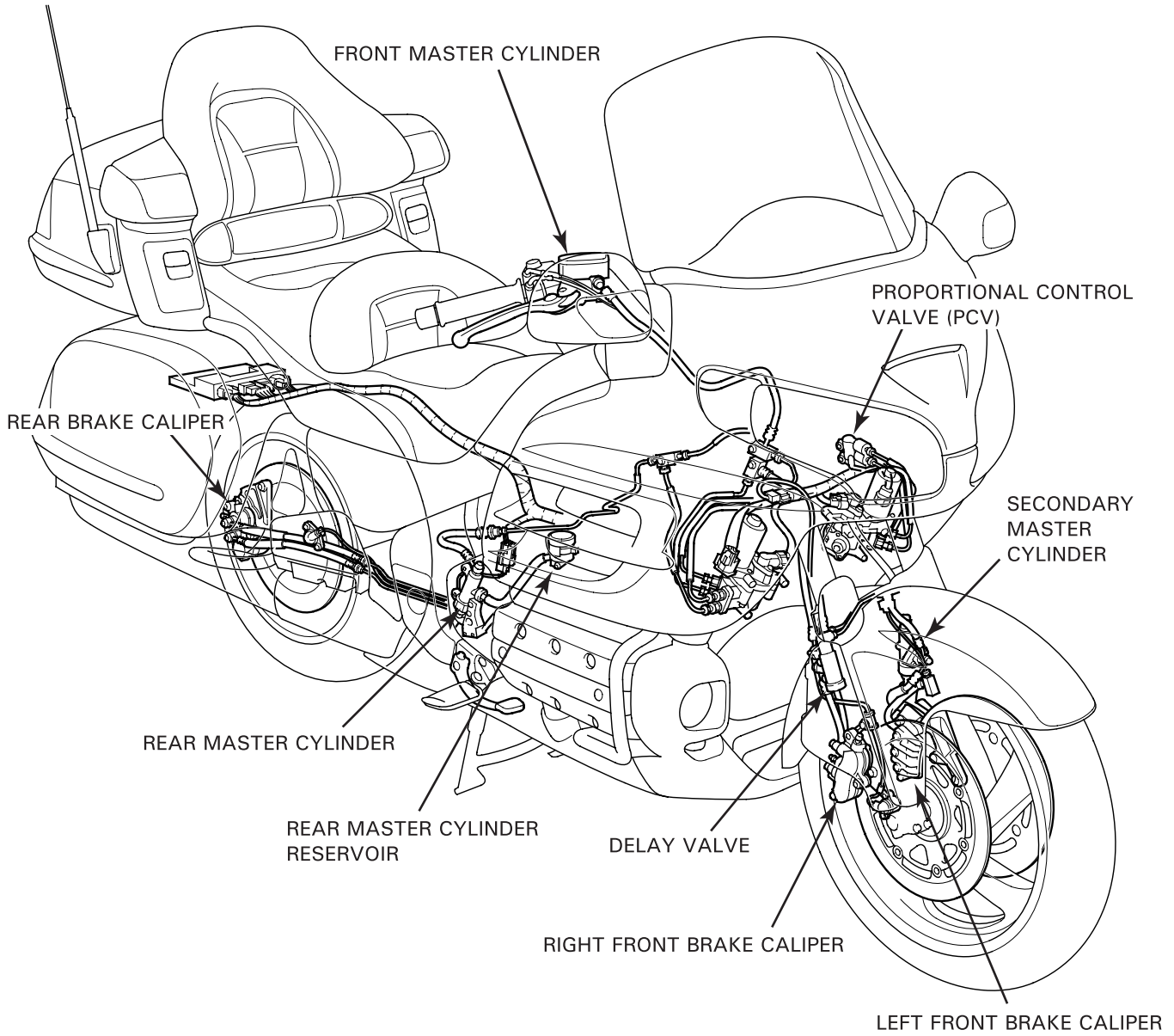



# SERVICE INFORMATION

## GENERAL

### ⚠ CAUTION

Frequent inhalation of brake lining dust, regardless of material composition, could be hazardous to your health.

- Avoid breathing dust particles.
- Never use an air hose or brush to clean brake assemblies. Use an OSHA-approved vacuum cleaner.

- This motorcycle is equipped with the following systems:
  - LBS (Linked Brake System) – that is designed to engage both front and rear brakes when either the brake lever or brake pedal is used.
  - ABS (Anti-lock Brake System) – that is designed to help prevent wheel lock-up during hard braking on loose or slippery surfaces.
- This section (15-A) covers service of the standard brake components (including LBS) of the brake system. For ABS service, see section 15-B.
- Note that there is no brake fluid in the ABS modulator (except in the modulator head), because the modulator is the motor-driven hydraulic pressure type. Therefore, brake fluid replacement and bleeding air from the modulator body is not necessary.
- A contaminated brake disc or pad reduces stopping power. Discard contaminated pads and clean a contaminated disc with a high quality brake degreasing agent.
- Spilled brake fluid will severely damage the plastic parts and painted surfaces. It is also harmful to some rubber parts. Be careful whenever you remove the reservoir cap; make sure the reservoir is horizontal first.
- Never allow contaminants (e.g., dirt, water) to enter an open reservoir.
- Once the hydraulic system has been opened, or if the brake feels spongy, the system must be bled.
- Always use fresh DOT 4 brake fluid from a sealed container when servicing the system. Do not mix different types of fluid as they may not be compatible.
- Always check brake operation before riding the motorcycle.

## SPECIFICATIONS

Unit: mm (in)

ITEM				STANDARD	SERVICE LIMIT	
Specified brake fluid				DOT 4	–	
Front	Brake disc thickness			4.5 (0.18)	3.5 (0.14)	
	Brake disc runout			–	0.30 (0.012)	
	Master cylinder I.D.			14.000 – 14.043 (0.5512 – 0.5529)	14.055 (0.5533)	
	Master piston O.D.			13.957 – 13.984 (0.5495 – 0.5506)	13.945 (0.5490)	
	Caliper cylinder I.D.	Left	Upper	22.650 – 22.700 (0.8917 – 0.8937)	22.71 (0.894)	
			Center	27.000 – 27.050 (1.0630 – 1.0650)	27.06 (1.065)	
			Lower	22.650 – 22.700 (0.8917 – 0.8937)	22.71 (0.894)	
		Right	Upper	25.400 – 25.450 (1.0000 – 1.0020)	25.46 (1.002)	
			Center	25.400 – 25.450 (1.0000 – 1.0020)	25.46 (1.002)	
			Lower	22.650 – 22.700 (0.8917 – 0.8937)	22.71 (0.894)	
	Caliper piston O.D.	Left	Upper	22.585 – 22.618 (0.8892 – 0.8905)	22.56 (0.888)	
			Center	26.935 – 26.968 (1.0604 – 1.0617)	26.91 (1.059)	
			Lower	22.585 – 22.618 (0.8892 – 0.8905)	22.56 (0.888)	
		Right	Upper	25.335 – 25.368 (0.9974 – 0.9987)	25.31 (0.996)	
Center			25.335 – 25.368 (0.9974 – 0.9987)	25.31 (0.996)		
Lower			22.585 – 22.618 (0.8892 – 0.8905)	22.56 (0.888)		
Rear	Brake disc thickness			11.0 (0.43)	10.0 (0.39)	
	Brake disc runout			–	0.30 (0.012)	
	Pedal master cylinder I.D.			17.460 – 17.503 (0.6874 – 0.6891)	17.515 (0.6896)	
	Pedal master piston O.D.			17.417 – 17.444 (0.6857 – 0.6868)	17.405 (0.6852)	
	Secondary master cylinder I.D.			14.000 – 14.043 (0.5512 – 0.5529)	14.055 (0.5533)	
	Secondary master piston O.D.			13.957 – 13.984 (0.5495 – 0.5506)	13.945 (0.5490)	
	Caliper cylinder I.D.			Upper	22.650 – 22.700 (0.8917 – 0.8937)	22.71 (0.894)
				Center	27.000 – 27.050 (1.0630 – 1.0650)	27.06 (1.065)
				Lower	22.650 – 22.700 (0.8917 – 0.8937)	22.71 (0.894)
	Caliper piston O.D.			Upper	22.585 – 22.618 (0.8892 – 0.8905)	22.56 (0.888)
				Center	26.935 – 26.968 (1.0604 – 1.0617)	26.91 (1.059)
				Lower	22.585 – 22.618 (0.8892 – 0.8905)	22.56 (0.888)

## BRAKE SYSTEM (Standard)

### TORQUE VALUES

Brake caliper bleed valve	6 N·m (0.6 kgf·m, 4.3 lbf·ft)	
Front fork anti-dive plunger bleed valve	6 N·m (0.6 kgf·m, 4.3 lbf·ft)	
Front master cylinder reservoir cap screw	2 N·m (0.2 kgf·m, 1.4 lbf·ft)	
Brake pad pin	18 N·m (1.8 kgf·m, 13 lbf·ft)	
Brake hose oil bolt	34 N·m (3.5 kgf·m, 25 lbf·ft)	
Brake lever pivot bolt	1 N·m (0.1 kgf·m, 0.7 lbf·ft)	
Brake lever pivot nut	6 N·m (0.6 kgf·m, 4.3 lbf·ft)	
Front brake light/cruise cancel switch screw	1 N·m (0.1 kgf·m, 0.7 lbf·ft)	
Front master cylinder holder bolt	12 N·m (1.2 kgf·m, 9 lbf·ft)	
Rear master cylinder reservoir mounting bolt	12 N·m (1.2 kgf·m, 9 lbf·ft)	
Rear master cylinder switch plate lock nut	18 N·m (1.8 kgf·m, 13 lbf·ft)	
Rear master cylinder joint nut	18 N·m (1.8 kgf·m, 13 lbf·ft)	
Rear master cylinder mounting bolt	12 N·m (1.2 kgf·m, 9 lbf·ft)	
Brake pedal pinch bolt	26 N·m (2.7 kgf·m, 20 lbf·ft)	
Rider footpeg mounting bolt	26 N·m (2.7 kgf·m, 20 lbf·ft)	
Rear brake light/cruise cancel switch holder screw	2 N·m (0.2 kgf·m, 1.4 lbf·ft)	
Secondary master cylinder mounting bolt	31 N·m (3.2 kgf·m, 23 lbf·ft)	Apply locking agent to the threads.
Front brake caliper bracket pin	13 N·m (1.3 kgf·m, 9 lbf·ft)	ALOC bolt: replace with a new one.
Front brake caliper pin	23 N·m (2.3 kgf·m, 17 lbf·ft)	Apply locking agent to the threads.
Front brake caliper assembly bolt	32 N·m (3.3 kgf·m, 24 lbf·ft)	
Left front brake caliper lower mounting bolt	31 N·m (3.2 kgf·m, 23 lbf·ft)	ALOC bolt: replace with a new one.
Left front brake caliper-to-secondary master cylinder joint bolt	25 N·m (2.6 kgf·m, 19 lbf·ft)	ALOC bolt: replace with a new one.
Right front brake caliper mounting bolt	31 N·m (3.2 kgf·m, 23 lbf·ft)	ALOC bolt: replace with a new one.
Wheel speed sensor bolt	12 N·m (1.2 kgf·m, 9 lbf·ft)	ALOC bolt: replace with a new one.
Rear brake caliper bracket pin	23 N·m (2.3 kgf·m, 17 lbf·ft)	Apply locking agent to the threads.
Rear brake caliper pin bolt	27 N·m (2.8 kgf·m, 20 lbf·ft)	
Rear brake caliper assembly bolt	32 N·m (3.3 kgf·m, 24 lbf·ft)	ALOC bolt: replace with a new one.
Rear brake disc screw	9 N·m (0.9 kgf·m, 6.5 lbf·ft)	ALOC screw: replace with a new one.
Rear brake caliper mounting bolt	45 N·m (4.6 kgf·m, 33 lbf·ft)	ALOC bolt: replace with a new one.
Proportional control valve mounting bolt	12 N·m (1.2 kgf·m, 9 lbf·ft)	
Delay valve mounting bolt	12 N·m (1.2 kgf·m, 9 lbf·ft)	
Brake pipe joint nut	17 N·m (1.7 kgf·m, 12 lbf·ft)	
Brake hose clamp bolt	12 N·m (1.2 kgf·m, 9 lbf·ft)	
Brake hose joint attaching bolt	12 N·m (1.2 kgf·m, 9 lbf·ft)	Apply brake fluid to the threads.

### TOOL

Snap ring pliers  
07914-SA50001

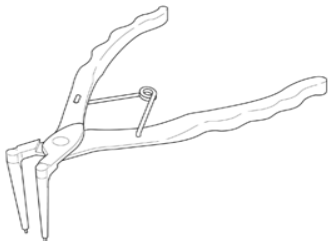

## **TROUBLESHOOTING**

### **Brake lever/pedal soft or spongy**

- Air in hydraulic system
- Leaking hydraulic system
- Contaminated brake pad/disc
- Worn caliper piston seals
- Worn master cylinder piston cups
- Worn brake pad/disc
- Contaminated caliper
- Contaminated master cylinder
- Caliper not sliding properly
- Low brake fluid level
- Clogged fluid passage
- Warped/deformed brake disc
- Sticking/worn caliper piston
- Sticking/worn master piston
- Bent brake lever/pedal

### **Brake lever/pedal hard**

- Clogged/restricted hydraulic system
- Sticking/worn caliper piston
- Sticking/worn master piston
- Caliper not sliding properly
- Bent brake lever/pedal

### **Brake drag**

- Contaminated brake pad/disc
- Misaligned wheel
- Badly worn brake pad/disc
- Warped/deformed brake disc
- Caliper not sliding properly
- Clogged/restricted fluid passage
- Sticking caliper piston
- Improper secondary master cylinder push rod length (rear brake)
- Faulty proportional control valve (rear brake)

### **Excessive nose dive and poor brake performance**

- Secondary master cylinder hydraulic line problem

## BRAKE SYSTEM (Standard)

# BRAKE FLUID REPLACEMENT/AIR BLEEDING

### NOTICE

- A contaminated brake disc or pad reduces stopping power. Discard contaminated pads and clean a contaminated disc with a high quality brake degreasing agent.
- Do not allow foreign material to enter the system when filling the reservoir.
- Avoid spilling fluid on painted, plastic or rubber parts. Place a rag over these parts whenever the system is serviced.
- Use only DOT 4 brake fluid from a sealed container.
- Do not mix different types of fluid. They are not compatible.

### NOTE:

- Once the hydraulic system has been opened, or if the brake feels spongy, the system must be bled.
- When using a commercially available brake bleeder, follow the manufacturer's operating instructions.

## BRAKE FLUID DRAINING

### LEVER BRAKE LINE

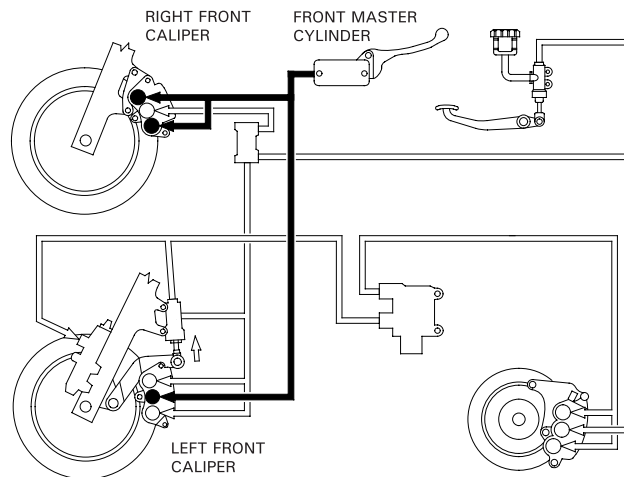

Remove front fender A and the fender covers (page 2-6).

Support the motorcycle on its center stand.

Turn the handlebar to the left until the front master cylinder reservoir is level before removing the reservoir cap.

Remove the screws, reservoir cap, set plate and diaphragm.



## BRAKE SYSTEM (Standard)

Connect a commercially available brake bleeder to the bleed valve of the front caliper at the position as shown.

Loosen the bleed valve and pump the brake bleeder until no more fluid flows out of the bleed valve. Tighten the bleed valve.



Perform the above procedure at the other front caliper.

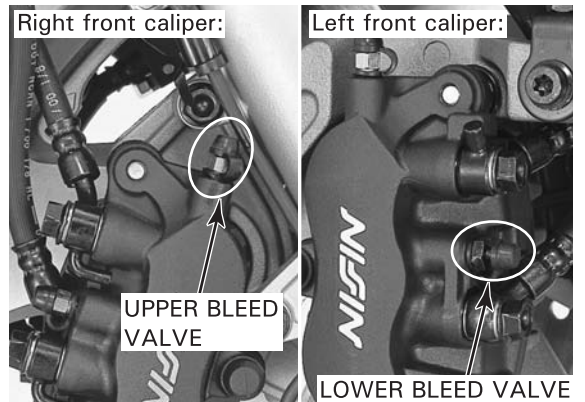

## PEDAL BRAKE LINE

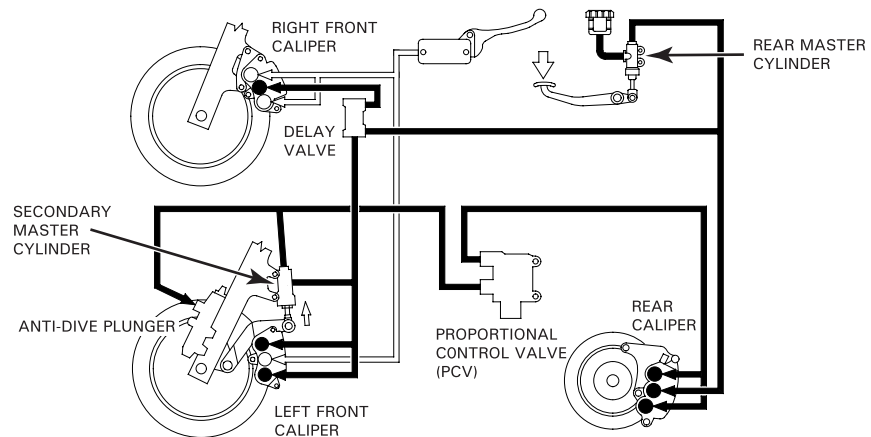

Remove the following:

- right engine side cover (page 2-5)
- front fender A and fender covers (page 2-6)

Support the motorcycle on its center stand.

Remove the rear master cylinder reservoir cap.



## BRAKE SYSTEM (Standard)

Connect a commercially available brake bleeder to the bleed valve of the brake pedal brake line as shown.  
Loosen the bleed valve and pump the brake bleeder until no more fluid flows out of the bleed valve.

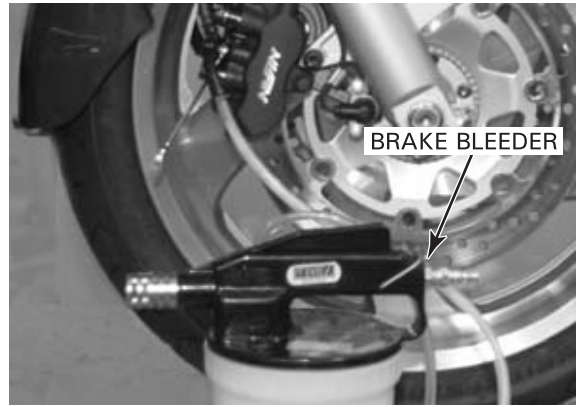

Perform the above procedure at each remaining valve of the brake pedal brake line.

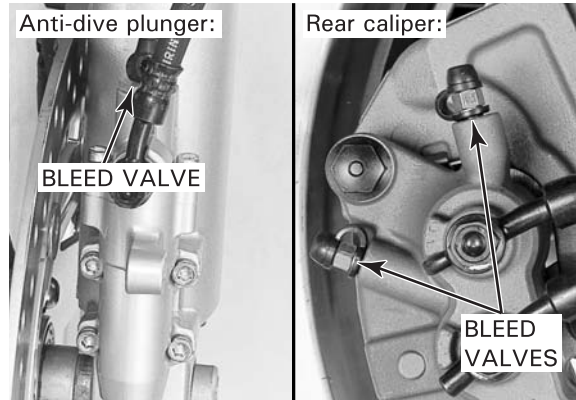
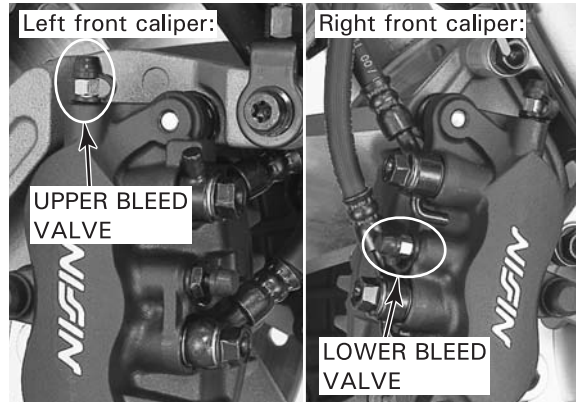

## LEVER BRAKE LINE FLUID FILLING/ AIR BLEEDING

### FLUID FEEDING

#### NOTE:

- It is not a problem if the fluid flowing out from the bleed valve contains air bubbles because the lines will be bled in next steps ("Air Bleeding").

Fill the reservoir with DOT 4 brake fluid from a sealed container.  
Operate the brake lever several times to bleed air from the master cylinder.

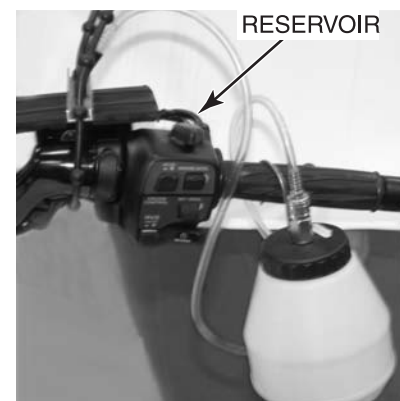



## BRAKE BLEEDER AVAILABLE

Check the fluid level often while bleeding the brake to prevent air from being pumped into the system. If air is entering the bleeder from around the bleed valve threads, seal the threads with teflon tape.

1. Connect a commercially available brake bleeder to the bleed valve of the front caliper at the position as shown. Pump the brake bleeder and loosen the bleed valve. If an automatic refill system is not used, add brake fluid when the fluid level in the reservoir is low. Repeat above procedure until sufficient amount of the fluid flows out from the bleed valve. Close the bleed valve.

### NOTE:

- When using a brake bleeding tool, follow the manufacturer's operating instructions.
2. Perform step 1 at the other front caliper.
- Next, perform the air bleeding without using a brake bleeder tool (page 15-10).

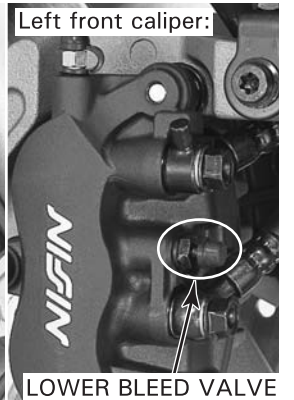
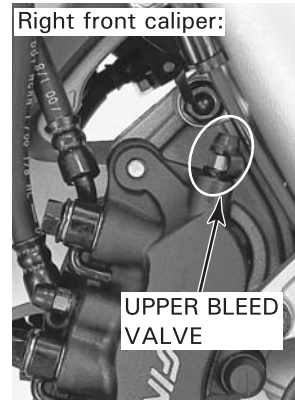

## BRAKE BLEEDER NOT AVAILABLE

Do not release the brake lever until the bleed valve has been closed.

1. Connect a bleed hose to the bleed valve of the front caliper. Pump the brake lever several (5 - 10) times quickly, then squeeze the brake lever all the way and loosen the bleed valve 1/4 turn. Wait several seconds and close the bleed valve. Release the brake lever slowly and wait several seconds after it reaches the end of its travel. Repeat above procedure until sufficient amount of fluid flows out of the bleed valve.
  2. Perform step 1 at the other front caliper.
- Next, perform the air bleeding (page 15-10).

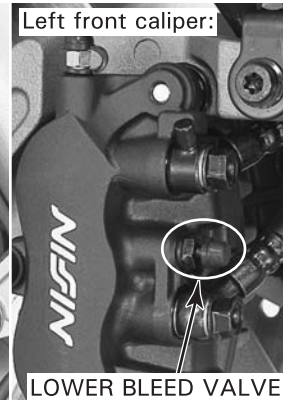
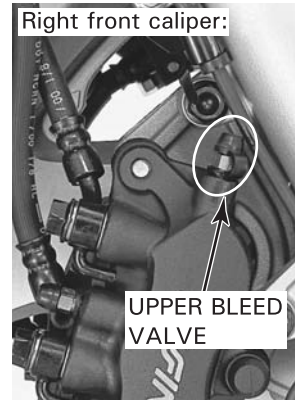

## BRAKE SYSTEM (Standard)

### AIR BLEEDING

Air bleeding procedure is performed in the same way as in the fluid feeding procedure without using a bleeder tool (page 15-9). Repeat this procedure until air bubbles do not appear in the plastic hose of each bleed valve.

Make sure that the bleed valves are closed and operate the brake lever. If it still feels spongy, bleed the system again.

After bleeding air completely, tighten the bleed valves.

**TORQUE: 6 N·m (0.6 kgf·m, 4.3 lbf·ft)**

Fill the reservoir to the casting ledge with DOT 4 brake fluid from a sealed container.

Install the diaphragm, set plate and reservoir cap and tighten the screws.

**TORQUE: 2 N·m (0.2 kgf·m, 1.4 lbf·ft)**

Install the fender covers and front fender A (page 2-6).



### PEDAL BRAKE LINE FLUID FILLING/ AIR BLEEDING

#### NOTE:

- Before performing this service, have at least 500 cc (16.9 US oz, 14.1 Imp oz) of brake fluid.
- Feed fluid and bleed air from the pedal brake line in the following sequence:
  1. Left front caliper upper side bleed valve
  2. Right front caliper lower side bleed valve
  3. Rear caliper lower side bleed valve
  4. Anti-dive plunger bleed valve
  5. Rear caliper upper side bleed valve

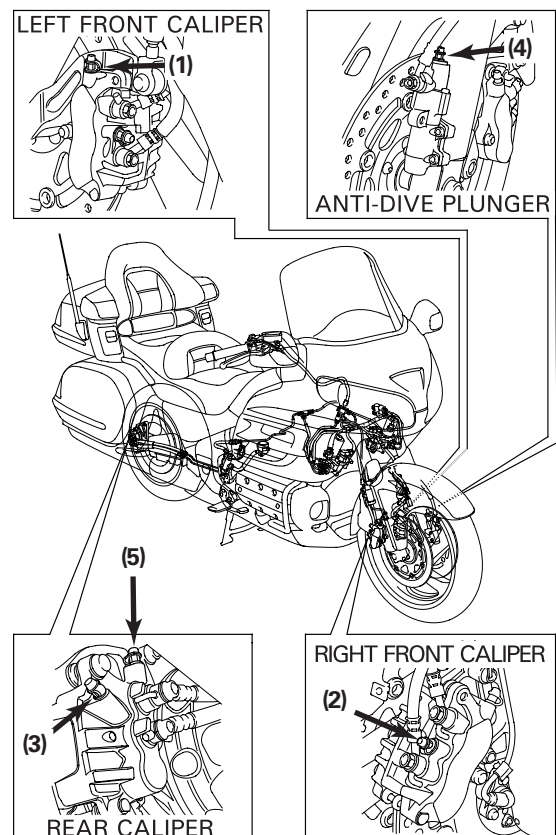

### FLUID FEEDING

#### NOTE:

- It is not a problem if the fluid flowing out of the bleed valve contains air bubbles because the lines will be bled in next steps ("Air Bleeding").

Fill the reservoir with DOT 4 brake fluid from a sealed container.

Operate the brake pedal several times until brake fluid level in the reservoir goes down.

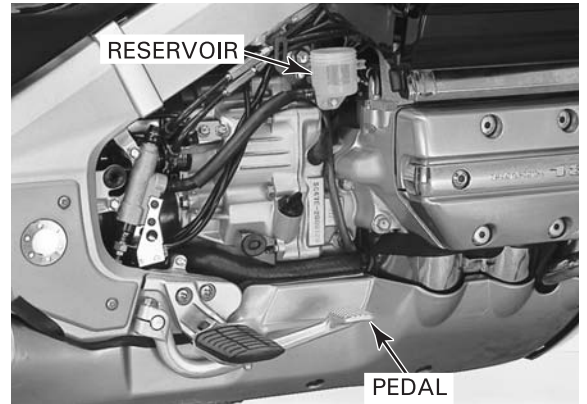

### BRAKE BLEEDER AVAILABLE

1. Connect a commercially available brake bleeder to the upper side bleed valve of the left front caliper.

*Check the fluid level often while bleeding the brake to prevent air from being pumped into the system. If air is entering the bleeder from around the bleed valve threads, seal the threads with teflon tape.*

Pump the brake bleeder and loosen the bleed valve.

If an automatic refill system is not used, add brake fluid when the fluid level in the reservoir is low.

Repeat above procedure until sufficient amount of the fluid flows out of the bleed valve. Close the bleed valve.

#### NOTE:

- When using a brake bleeding tool, follow the manufacturer's operating instructions.

Perform step 1 at each bleed valve in the sequence as follows:

2. Right front caliper lower side bleed valve
3. Rear caliper lower side bleed valve
4. Anti-dive plunger bleed valve
5. Rear caliper upper side bleed valve

Next, perform the air bleeding without using a brake bleeder tool (page 15-12).

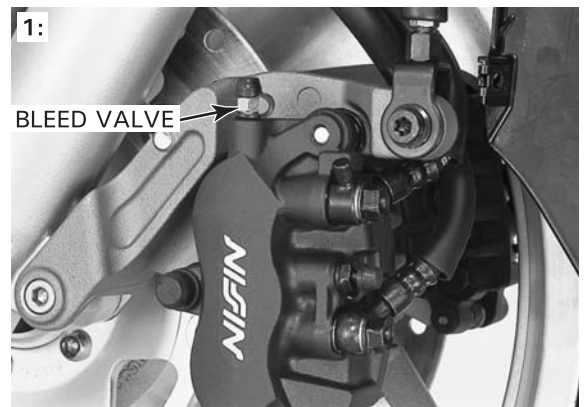

## BRAKE SYSTEM (Standard)

### BRAKE BLEEDER NOT AVAILABLE

1. Connect a bleed hose to the upper side bleed valve of the left front caliper.

*Do not release the brake lever until the bleed valve has been closed.*

Pump the brake pedal several (5 – 10) times quickly, then depress the brake pedal all the way and loosen the bleed valve 1/4 turn. Wait several seconds and close the bleed valve.

Release the brake pedal slowly and wait several seconds after it reaches the end of its travel.

Repeat above procedure until sufficient amount of the fluid flows out of the bleed valve.

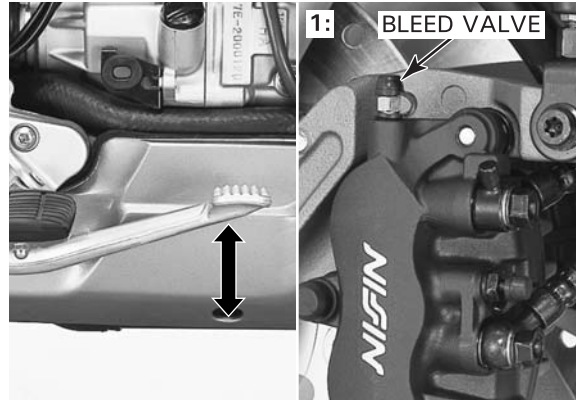

Perform step 1 at each bleed valve in the sequence as follows:

2. Right front caliper lower side bleed valve
3. Rear caliper lower side bleed valve
4. Anti-dive plunger bleed valve
5. Rear caliper upper side bleed valve

Next, perform the air bleeding.

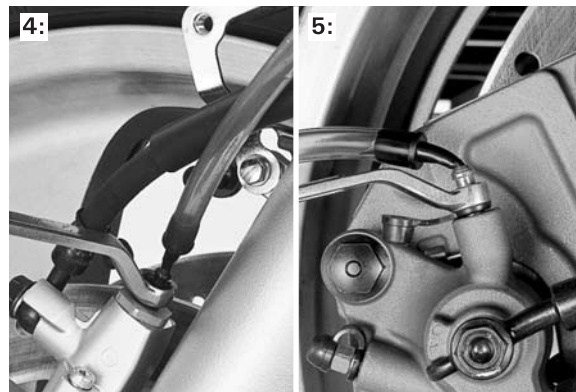
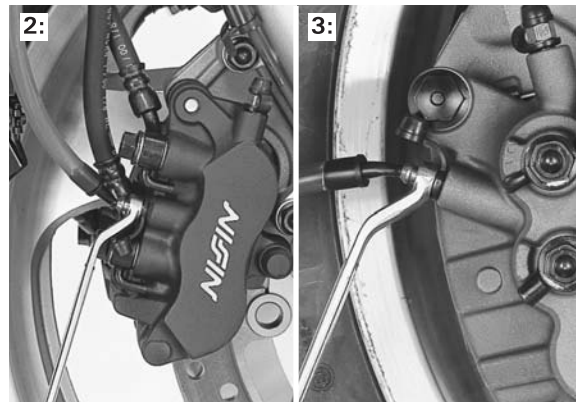

### AIR BLEEDING

#### NOTE:

- Note that you may feel strong resistance on the brake pedal during pumping to bleed air from the right front caliper. This symptom is caused by the delay valve function. Be sure to depress the brake pedal fully to the bottom.

Air bleeding procedure must be performed in the same way as in the fluid feeding procedure without using a brake bleeder tool (page 15-11).

Repeat this procedure until air bubbles do not appear in the plastic hose of each bleed valve.

After air bubbles cease to appear in the fluid, repeat air bleeding procedure about 2 – 3 times.

Make sure that the bleed valves are closed and operate the brake pedal. If it still feels spongy, bleed the system again.



After bleeding air completely, tighten the bleed valves.

**TORQUE: 6 N·m (0.6 kgf·m, 4.3 lbf·ft)**

Fill the reservoir to the upper level line with DOT 4 brake fluid from a sealed container. Install the reservoir cap.

Check the pedal brake operation (page 3-18).

Install the following:

- fender covers and front fender A (page 2-6)
- right engine side cover (page 2-5)

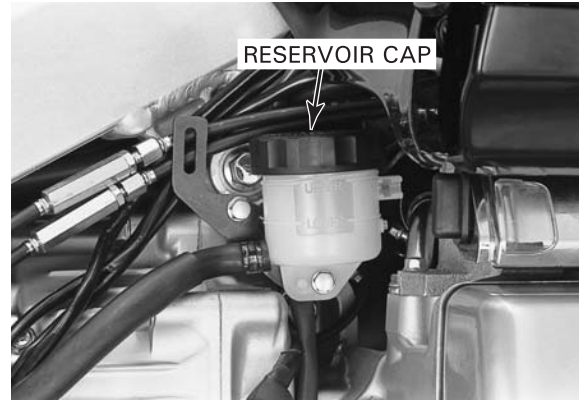

## BRAKE PAD/DISC

### FRONT BRAKE PAD REPLACEMENT

*Always replace the brake pads in pairs to ensure even disc pressure. Check the brake fluid level in the brake reservoir as this operation causes the level to rise.*

Push the caliper piston all the way in to allow installation of new brake pads by pushing the caliper body inward.

Remove the pad pin plug and loosen the pad pin.

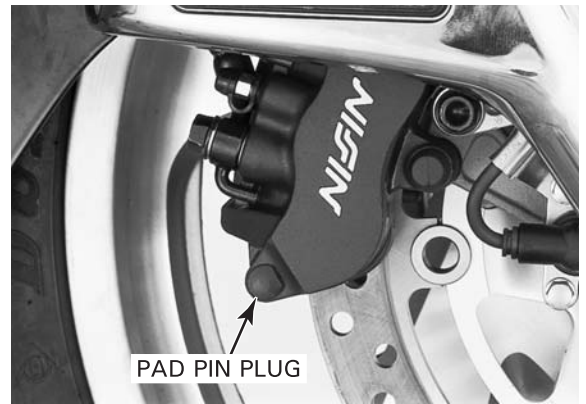

Pull the pad pins out of the caliper body while pushing in the pads against the pad spring. Remove the brake pads.

Coat the stopper ring on the pad pin end with silicone grease.

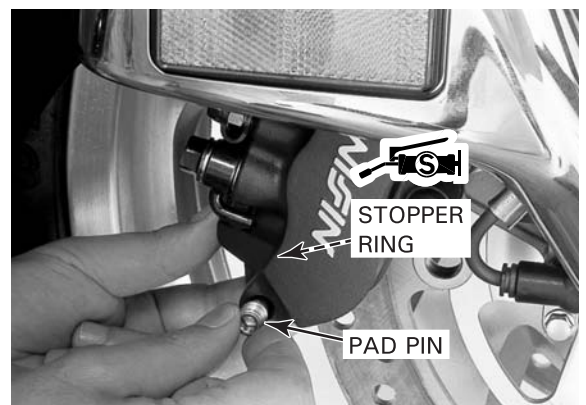

Install new brake pads into the caliper body with the shim facing toward the wheel side so that their ends rest into the pad retainer on the bracket properly.

Install the pad pin by pushing in the pads against the pad spring to align the pad pin holes in the pads and caliper body.

Tighten the pad pin.

**TORQUE: 18 N·m (1.8 kgf·m, 13 lbf·ft)**

Install the pad pin plug securely.

Operate the brake lever and pedal to seat the caliper piston against the pads.

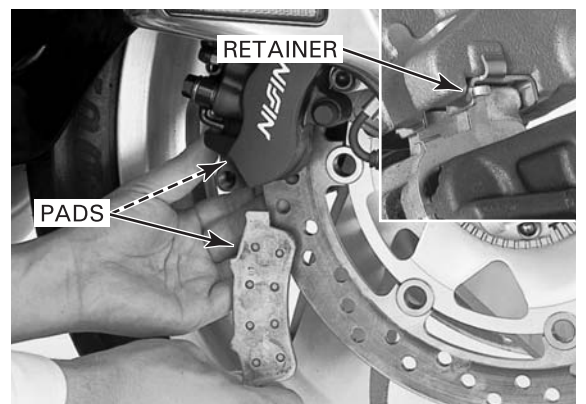

*Make sure the pad spring is installed correctly.*

## BRAKE SYSTEM (Standard)

### REAR BRAKE PAD REPLACEMENT

*Always replace the brake pads in pairs to ensure even disc pressure.  
Check the brake fluid level in the brake reservoirs as this operation causes the level to rise.*

Push the caliper piston all the way in to allow installation of new brake pads by pushing the caliper body inward.

Remove the pad pin plug and loosen the pad pin.

Pull the pad pins out of the caliper body while pushing in the pads against the pad spring. Remove the brake pads.

Coat the stopper ring on the pad pin end with silicone grease.

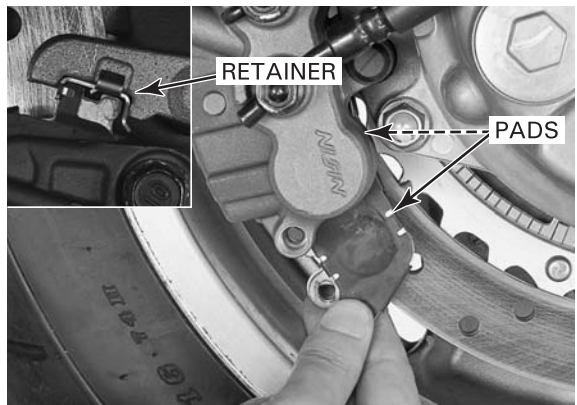
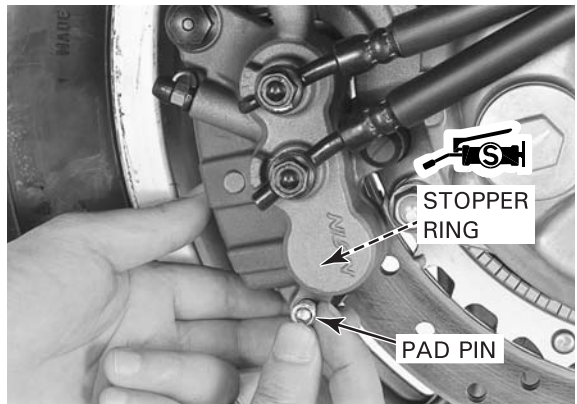
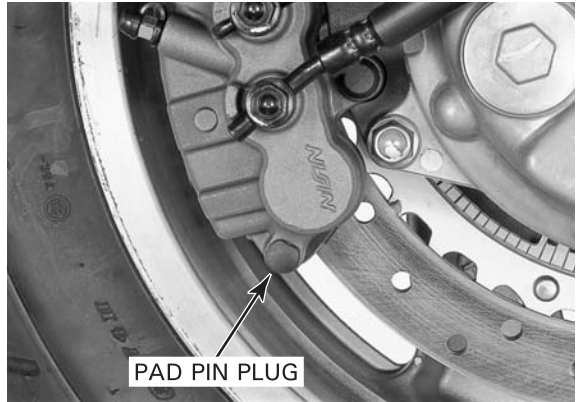

*Make sure the pad spring is installed correctly.*

Install new brake pads into the caliper body so that their ends rest into the pad retainer on the bracket properly.

Install the pad pin by pushing in the pads against the pad spring to align the pad pin holes in the pads and caliper body.

Tighten the pad pin.

**TORQUE: 18 N·m (1.8 kgf·m, 13 lbf·ft)**

Install the pad pin plug securely.

Operate the brake pedal and right front caliper to seat the caliper piston against the pads.

### BRAKE DISC INSPECTION

Visually inspect the disc for damage or cracks.

Measure the brake disc thickness at several points.

**SERVICE LIMITS: Front: 3.5 mm (0.14 in)  
Rear: 10.0 mm (0.39 in)**



Measure the brake disc warpage with a dial indicator.

**SERVICE LIMIT: 0.30 mm (0.012 in)**

Check the bearing for excessive play, if the warpage exceeds the service limit.

Replace the brake disc if the bearings are normal.

For brake disc removal/installation, see section 13 or 14.

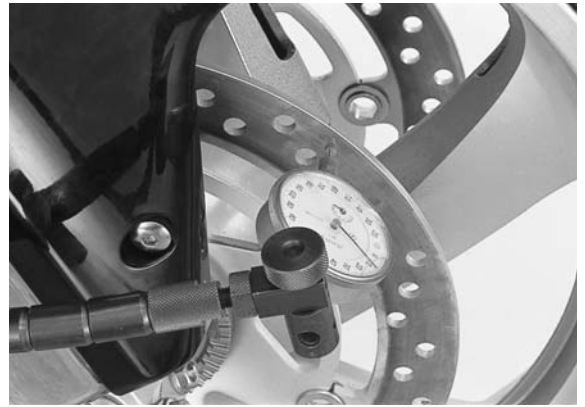

## FRONT MASTER CYLINDER

### DISASSEMBLY

Drain the brake fluid from the front lever brake hydraulic system (page 15-6).

Disconnect the brake light/cruise cancel switch connectors.

*When removing the oil bolt, cover the end of the hose to prevent contamination.*

Disconnect the brake hose from the master cylinder by removing the oil bolt and sealing washers.

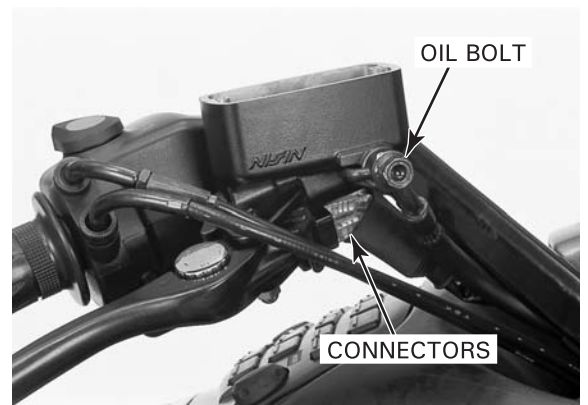

Remove the holder cap.  
Remove the master cylinder holder bolts, holder and the master cylinder.

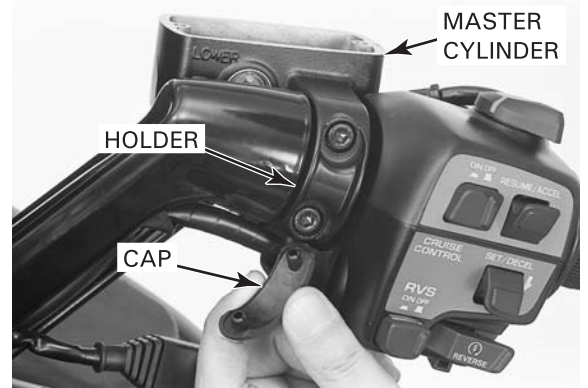

Remove the following from the master cylinder:

- screw and brake light/cruise cancel switch
- pivot nut
- pivot bolt and brake lever

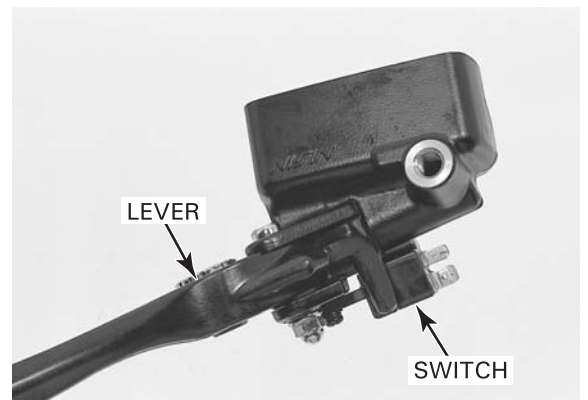

## BRAKE SYSTEM (Standard)

- piston boot
- snap ring

### TOOL:

Snap ring pliers

07914-SA50001

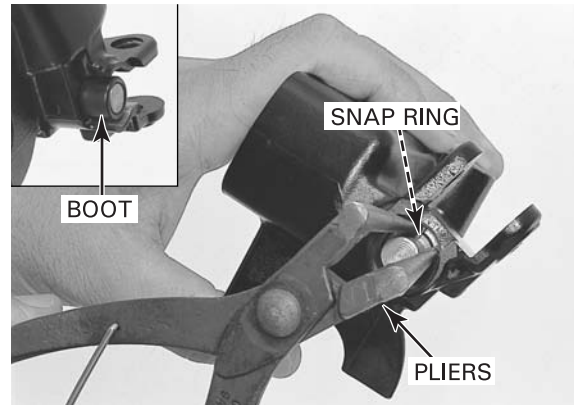

- master piston
- primary cup
- spring

Clean the master cylinder, reservoir and master piston in clean brake fluid.

### INSPECTION

Check the piston cups and boot for wear, deterioration or damage.  
Check the spring for damage.

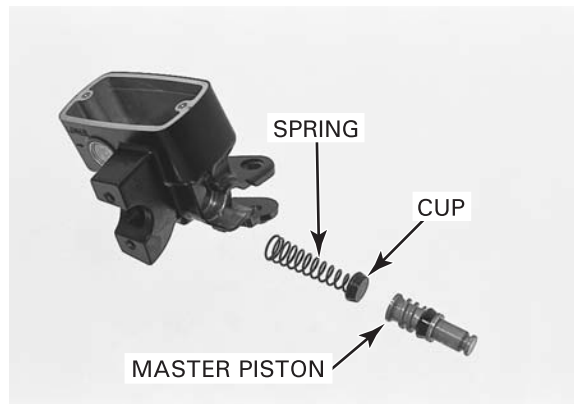

Check the master cylinder and piston for scoring, scratches or damage.  
Measure the master cylinder I.D.

**SERVICE LIMIT: 14.055 mm (0.5533 in)**

Measure the master piston O.D.

**SERVICE LIMIT: 13.945 mm (0.5490 in)**



**ASSEMBLY**

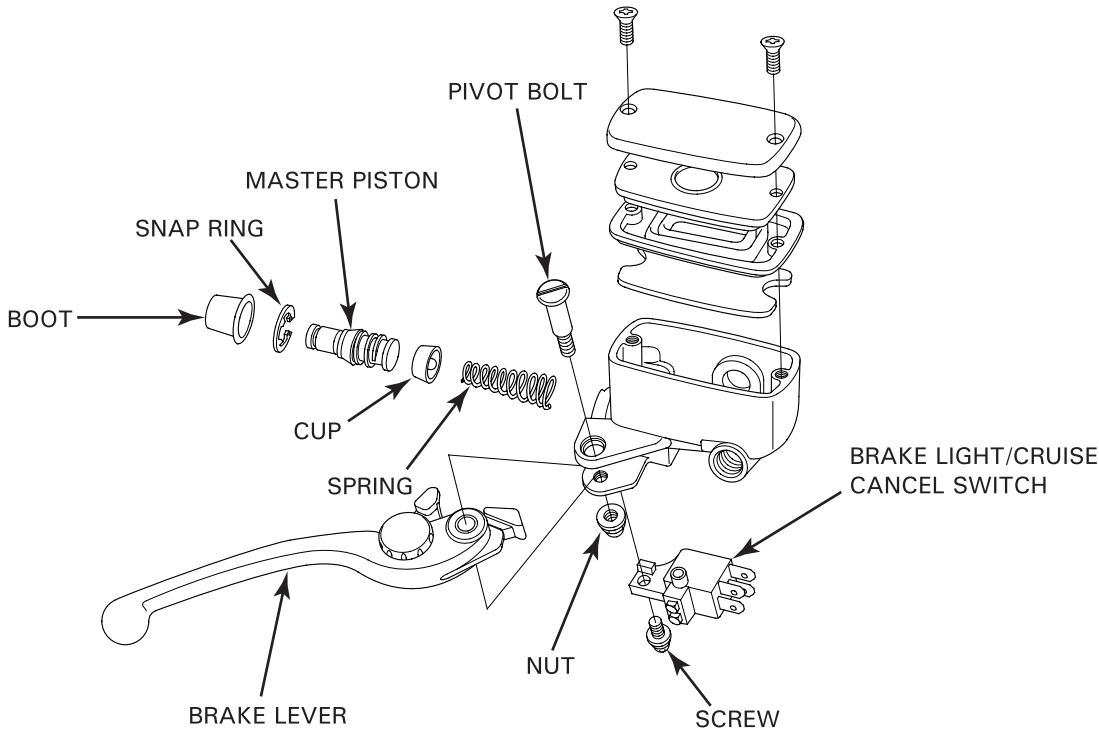

*Do not allow the piston cup lips to turn inside out.*

Coat the master piston and piston cups with clean brake fluid. Install the primary cup onto the spring. Install the spring and master piston into the master cylinder.

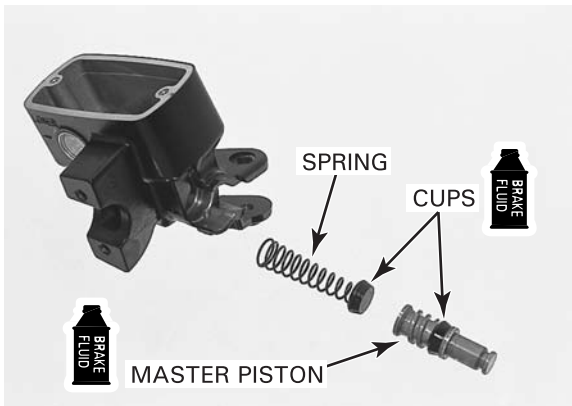

*Make sure the snap ring is firmly seated in the groove.*

Install the snap ring into the groove in the master cylinder using the special tool.

**TOOL:**  
**Snap ring pliers**                      **07914-SA50001**

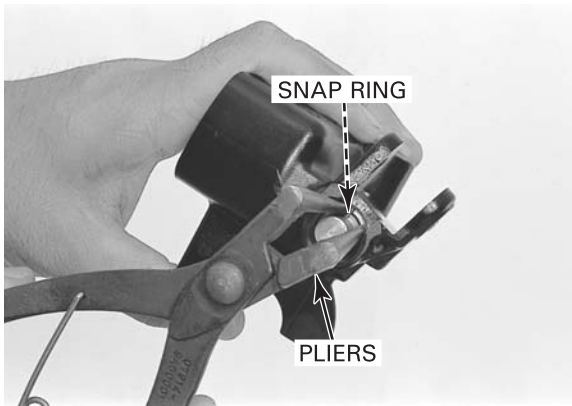

## BRAKE SYSTEM (Standard)

Apply silicone grease to the push rod contacting area of the master piston.  
Install the boot into the master cylinder and the piston groove.

Apply silicone grease to the brake lever contacting surface of the piston.

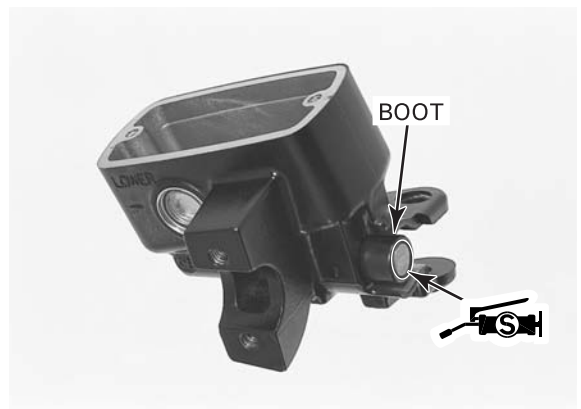

Apply silicone grease to the brake lever pivot.  
Install the brake lever and pivot bolt, and tighten it.

**TORQUE: 1 N·m (0.1 kgf·m, 0.7 lbf·ft)**

Install the pivot nut and tighten it.

**TORQUE: 6 N·m (0.6 kgf·m, 4.3 lbf·ft)**

Install the brake light/cruise cancel switch with the screw.

**TORQUE: 1 N·m (0.1 kgf·m, 0.7 lbf·ft)**

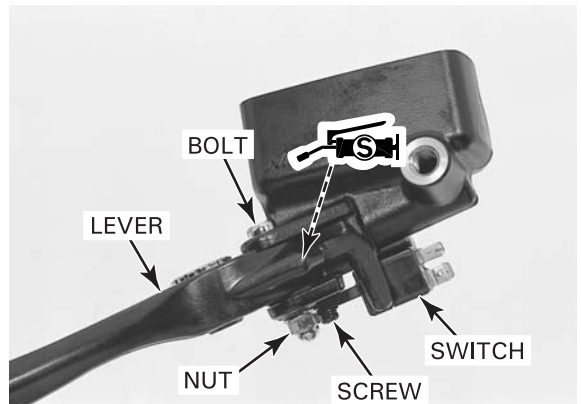

Install the master cylinder and holder by aligning the end of the master cylinder with the punch mark on the handlebar. Tighten the upper bolt first, then tighten the lower bolt.

**TORQUE: 12 N·m (1.2 kgf·m, 9 lbf·ft)**

Install the holder cap into the holder bolts.

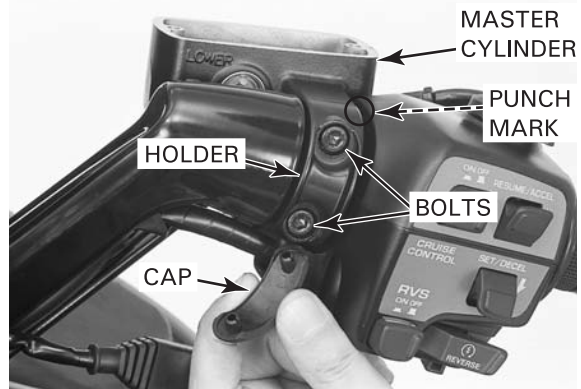

Connect the brake hose to the master cylinder with the oil bolt and new sealing washers.  
Be sure to rest the hose joint pin against the stopper.  
Tighten the oil bolt.

**TORQUE: 34 N·m (3.5 kgf·m, 25 lbf·ft)**

Connect the brake light/cruise cancel switch connectors.

Fill and bleed the lever brake hydraulic system (page 15-6).

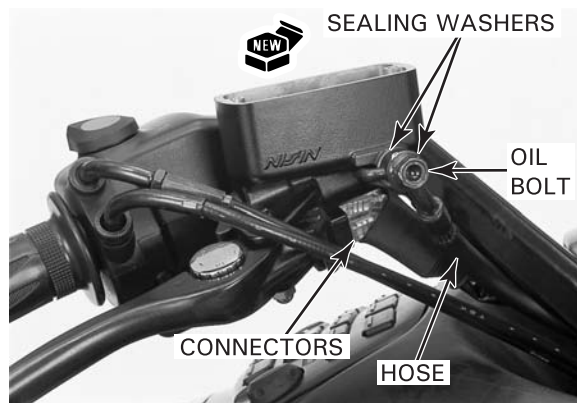

# REAR MASTER CYLINDER/BRAKE PEDAL

## REMOVAL

Drain the brake fluid from the pedal brake hydraulic system (page 15-6).

Remove the two screws and brake light/cruise cancel switch assembly from the master cylinder.

*When removing the hose joint and oil bolt, cover the ends of the hoses to prevent contamination.*

Remove the snap ring and disconnect the reservoir hose joint from the master cylinder. Remove the O-ring.

Disconnect the brake hose by removing the oil bolt and sealing washers.

Remove the pinch bolt and the brake pedal. Remove the two bolts and right footpeg.

Unhook the spring end to remove the return spring from the frame and pivot arm.

Remove the master cylinder mounting bolts. Remove the pedal pivot arm off the frame while pushing the water hose aside, then the master cylinder/pivot arm assembly out of the frame.

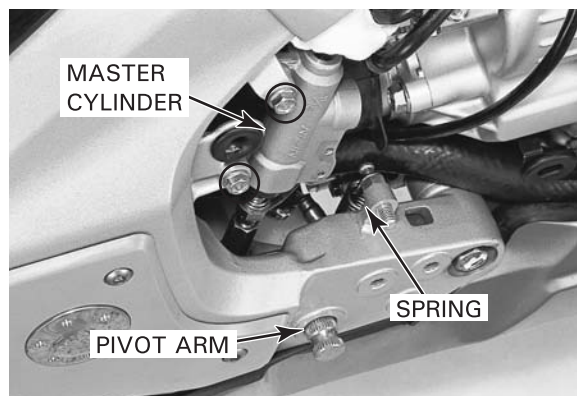
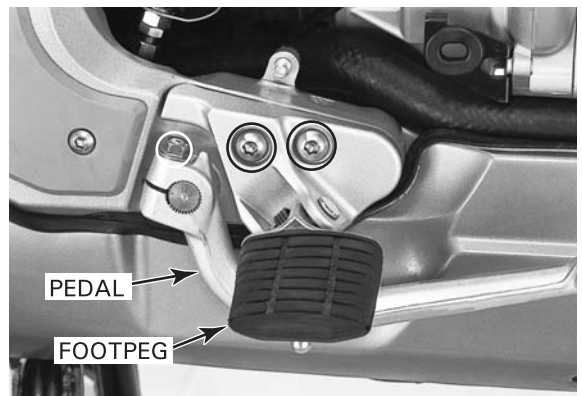
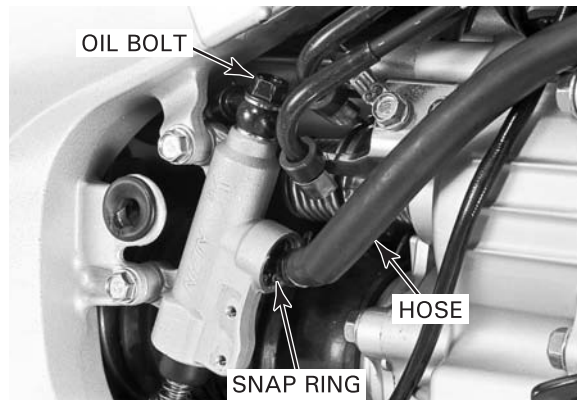
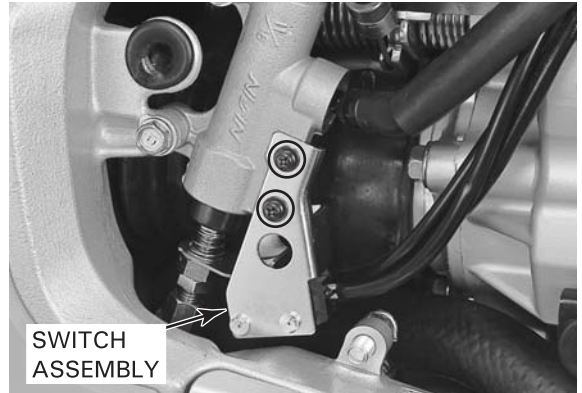



## BRAKE SYSTEM (Standard)

### DISASSEMBLY

Remove the following from the master cylinder:

- cotter pin
- joint pin
- pivot arm

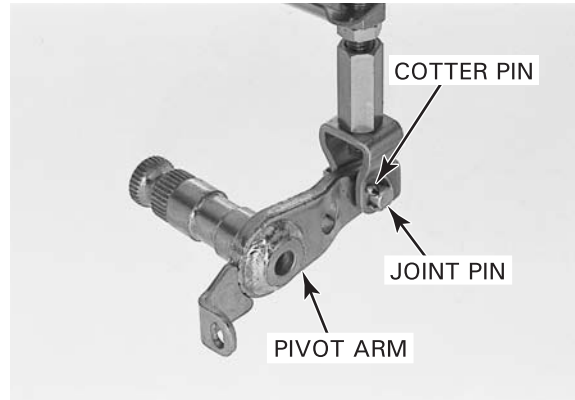

- boot (from the master cylinder)
- snap ring

#### TOOL:

**Snap ring pliers**

**07914-SA50001**

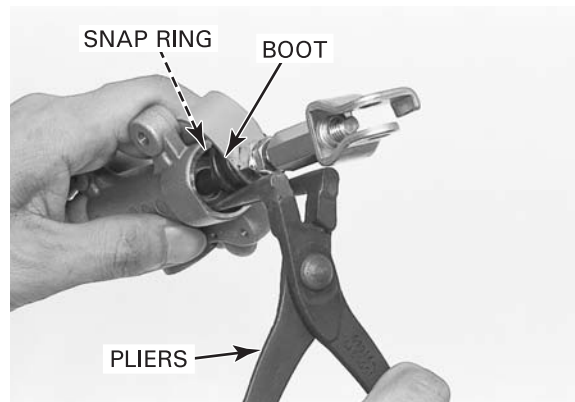

- piston/push rod assembly
- primary cup
- spring

Clean the master cylinder and master piston in clean brake fluid.

### INSPECTION

Check the piston cups and boot for wear, deterioration or damage.  
Check the spring for damage.

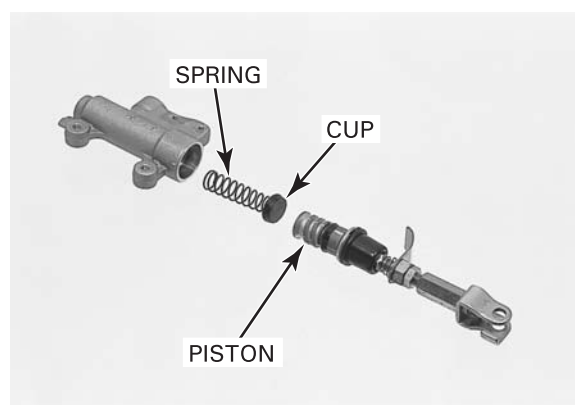

Check the master cylinder and piston for scoring, scratches or damage.  
Measure the master cylinder I.D.

**SERVICE LIMIT: 17.515 mm (0.6896 in)**

Measure the master piston O.D.

**SERVICE LIMIT: 17.405 mm (0.6852 in)**

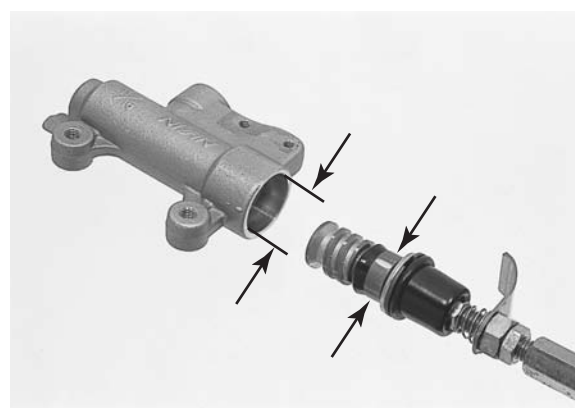



**ASSEMBLY**

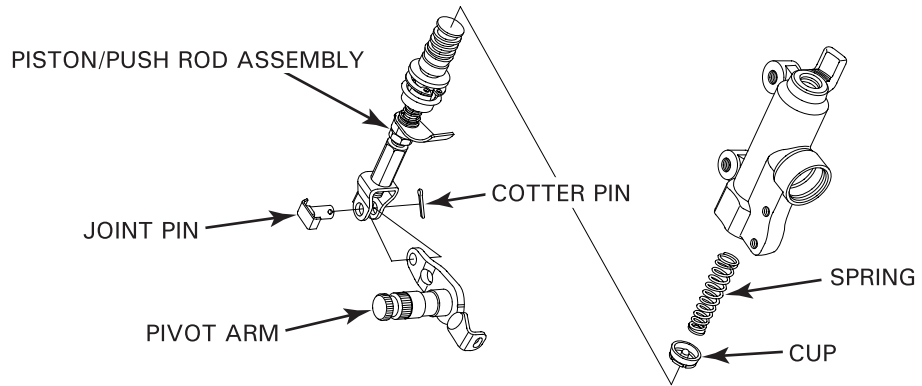

*Do not allow the piston cup lips to turn inside out.*

Coat the master piston and piston cups with clean brake fluid. Install the primary cup onto the spring. Install the spring and piston/push rod assembly into the master cylinder.

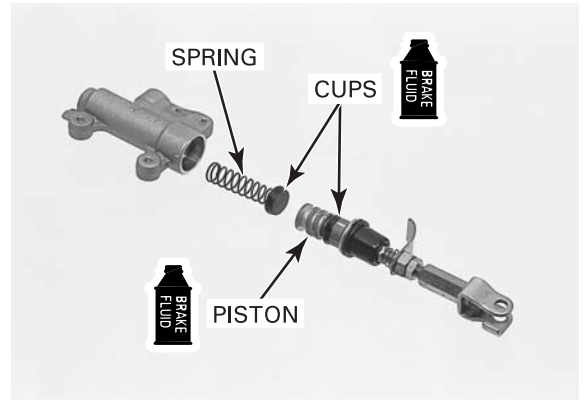

*Make sure the snap ring is firmly seated in the groove.*

Install the snap ring into the groove in the master cylinder using the special tool.

**TOOL:**  
**Snap ring pliers**                      **07914-SA50001**

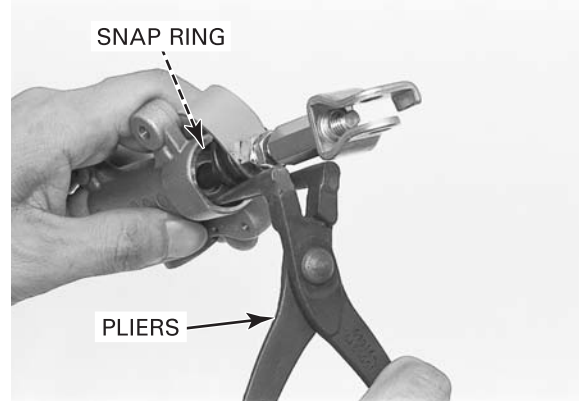

Apply silicone grease to the boot groove in the push rod and install the boot into the master cylinder and boot groove.

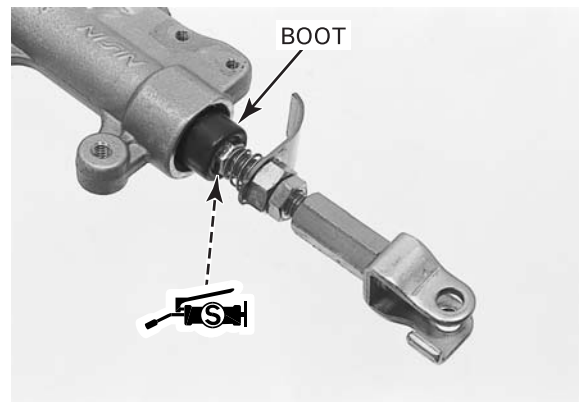

## BRAKE SYSTEM (Standard)

If the push rod joint is reinstalled, adjust the push rod length so the distance from the center of the lower mounting bolt hole to the center of the joint pin hole is 106 mm (4.2 in). After adjustment, tighten the joint nut.

**TORQUE: 18 N·m (1.8 kgf·m, 13 lbf·ft)**

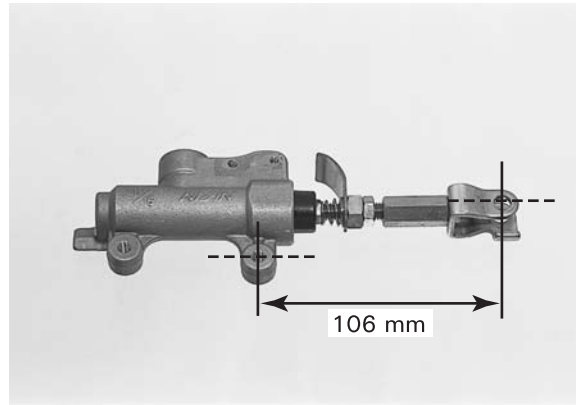

Install the pivot arm into the master cylinder push rod joint with the joint pin and a new cotter pin.

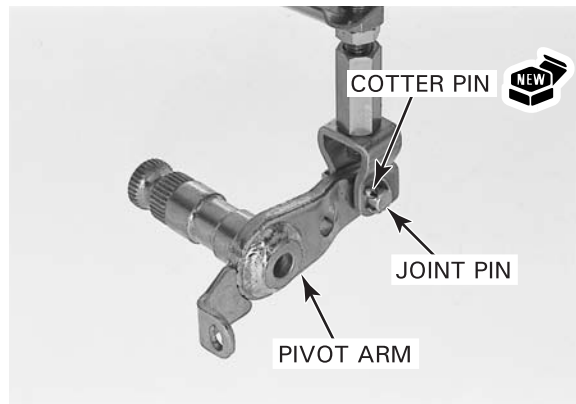

## INSTALLATION

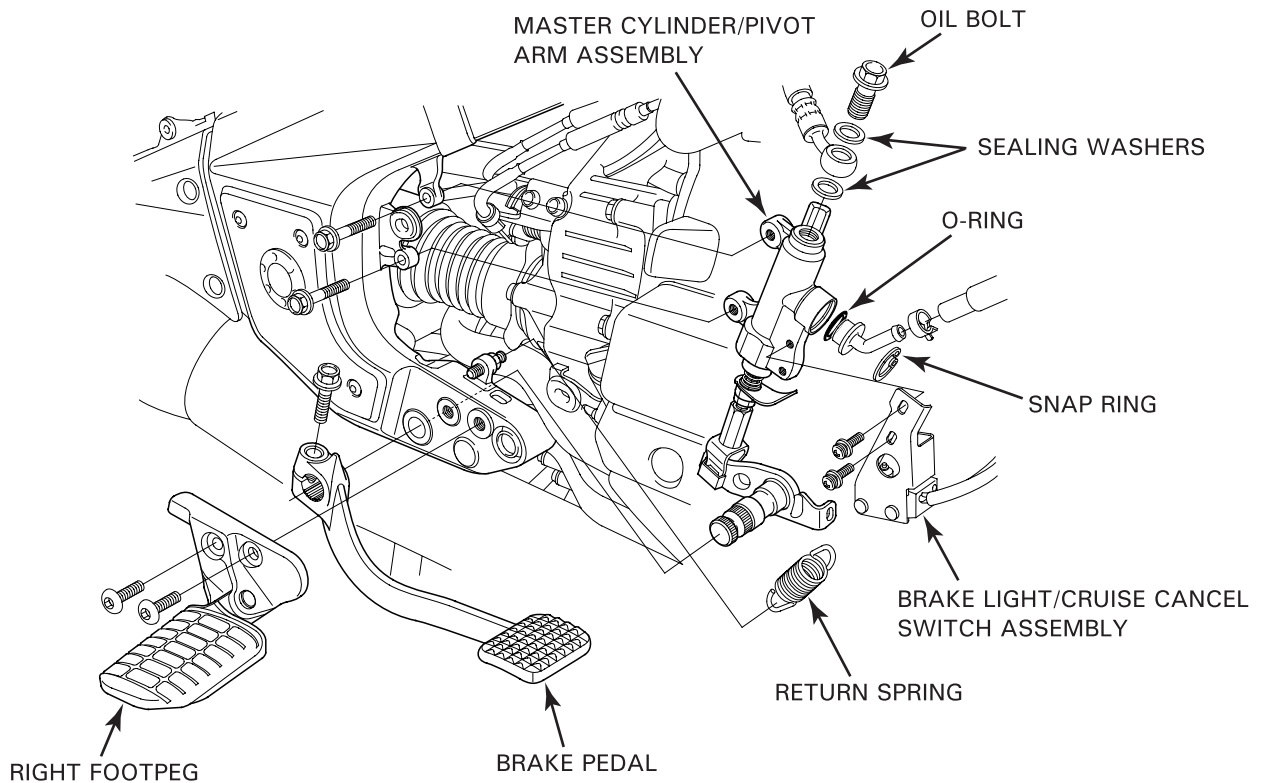

Apply grease to the pivot shaft groove of the pivot arm.

Place the master cylinder/pivot arm assembly into the frame while pushing the water hose aside and insert the pivot arm into the pivot hole, being careful not to damage its splines.

Install the master cylinder onto the frame and tighten the mounting bolts.

**TORQUE: 12 N·m (1.2 kgf·m, 9 lbf·ft)**

Install the return spring into the pivot arm and onto the frame stopper pin.

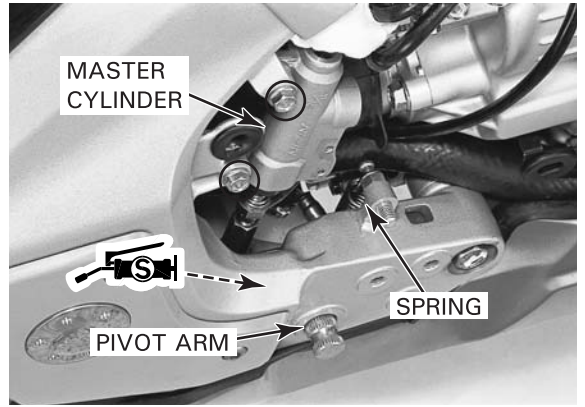

Apply brake fluid to a new O-ring and install it onto the reservoir joint.

*Make sure the snap ring is firmly seated in the groove.*

Install the reservoir hose joint into the master cylinder and secure it with the snap ring.

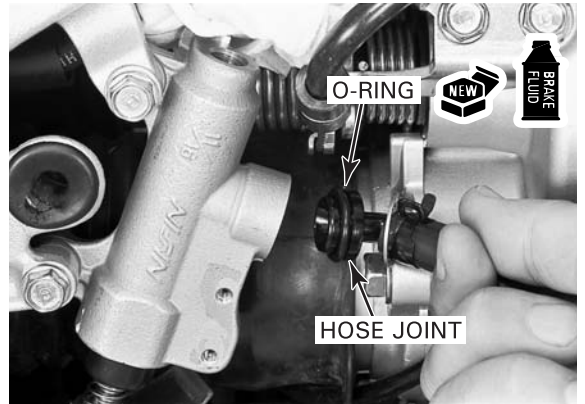

Connect the brake hose to the master cylinder with the oil bolt and new sealing washers, and tighten the oil bolt.

**TORQUE: 34 N·m (3.5 kgf·m, 25 lbf·ft)**

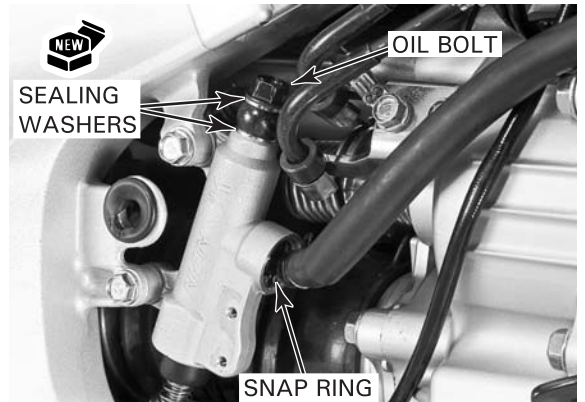

Install the brake pedal by aligning the slit with the punch mark on the pivot arm.

Install the pinch bolt and tighten it.

**TORQUE: 26 N·m (2.7 kgf·m, 20 lbf·ft)**

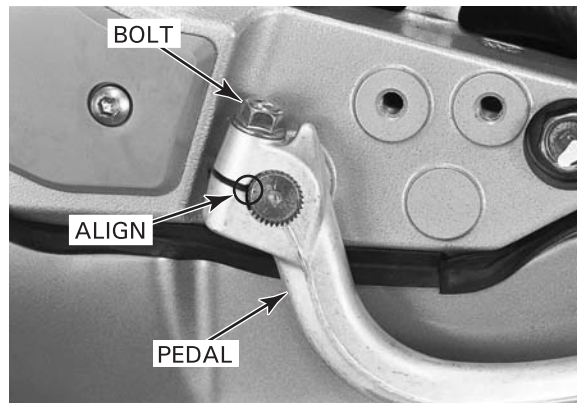

## BRAKE SYSTEM (Standard)

Install the footpeg and tighten the bolts.

**TORQUE: 26 N·m (2.7 kgf·m, 20 lbf·ft)**

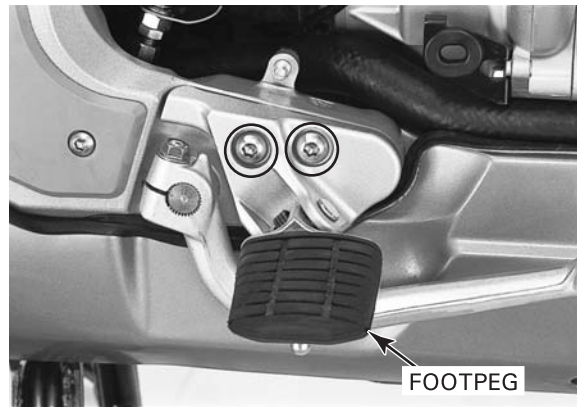

Apply locking agent to the threads of the switch holder screws.

Install the brake light/cruise cancel switch assembly with the screws.

Adjust the switch position so that the brake light comes on when pushing the brake pedal slightly and the push rod moves 0.7 – 1.7 mm.

Tighten the switch holder screws.

**TORQUE: 2 N·m (0.2 kgf·m, 1.4 lbf·ft)**

Fill and bleed the pedal brake hydraulic system (page 15-7).

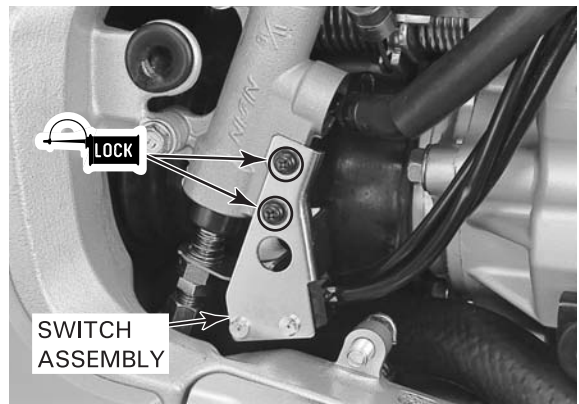

## SECONDARY MASTER CYLINDER

### DISASSEMBLY

Drain the brake fluid from the pedal brake hydraulic system (page 15-6).

*When removing the oil bolt, cover the ends of the hoses to prevent contamination.*

Remove the following:

- front fender B (page 13-16)
- oil bolt and sealing washers
- upper side brake hose

- caliper-to-master cylinder joint bolt
- mounting bolts

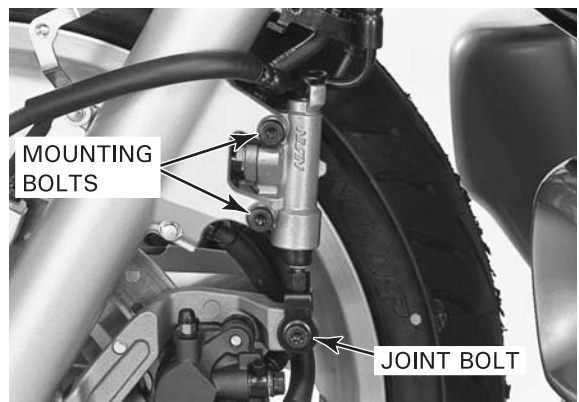

## BRAKE SYSTEM (Standard)

- oil bolt and sealing washers (while holding the master cylinder firmly)
- front side brake hose
- secondary master cylinder
- pivot collar (from the caliper bracket)

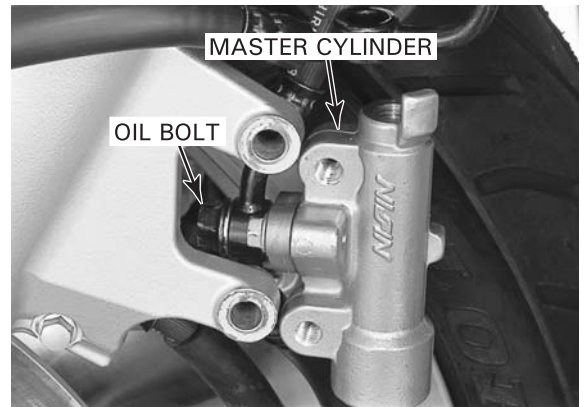

- boot (from the master cylinder)
- snap ring

### TOOL:

**Snap ring pliers**

**07914-SA50001**

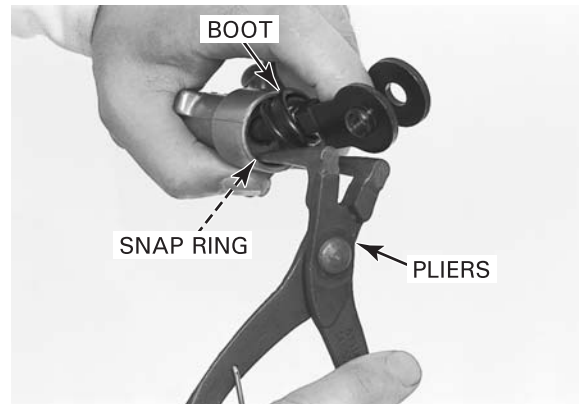

- master piston
- primary cup
- spring

Clean the master cylinder and master piston in clean brake fluid.

### INSPECTION

Check the piston cups and boot for wear, deterioration or damage.

Check the spring for damage.

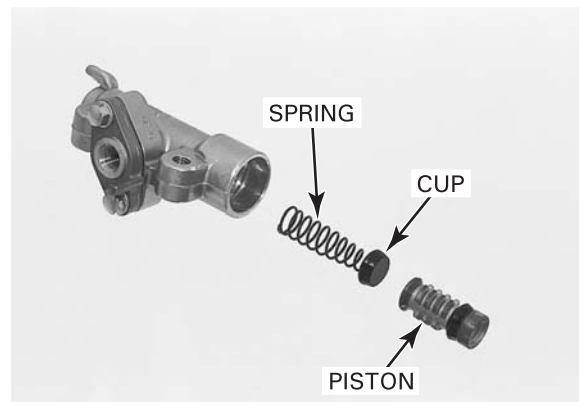

Check the master cylinder and piston for scoring, scratches or damage.

Measure the master cylinder I.D.

**SERVICE LIMIT: 14.055 mm (0.5533 in)**

Measure the master piston O.D.

**SERVICE LIMIT: 13.945 mm (0.5490 in)**

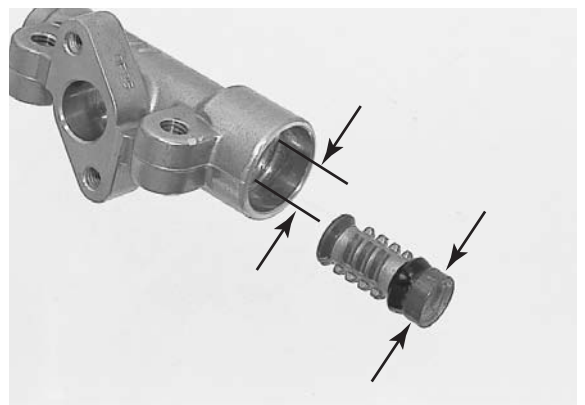



# BRAKE SYSTEM (Standard)

## ASSEMBLY

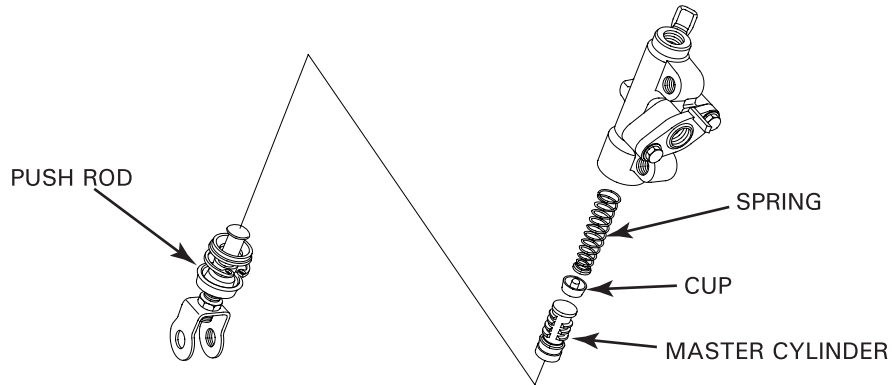

*Do not allow the piston cup lips to turn inside out.*

Coat the master piston and piston cups with clean brake fluid. Install the primary cup onto the spring. Install the spring and master piston into the master cylinder.

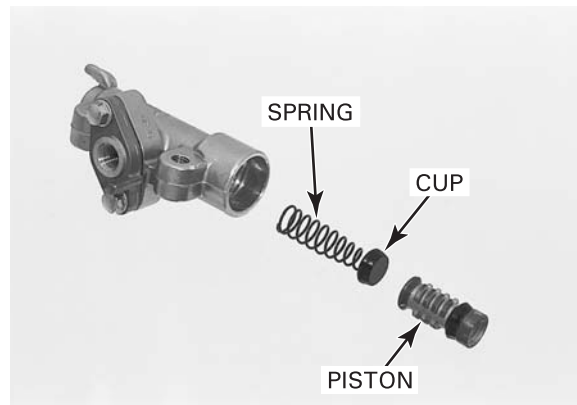

*Make sure the snap ring is firmly seated in the groove.*

Install the push rod into the master cylinder. Install the snap ring into the groove in the master cylinder using the special tool.

**TOOL:**  
**Snap ring pliers**                      **07914-SA50001**

Apply silicone grease to the boot groove in the push rod and install the boot into the master cylinder and boot groove.

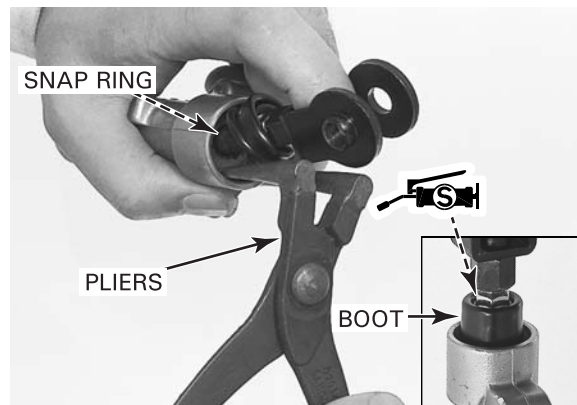

If the push rod joint is reinstalled, adjust the push rod length so the distance from the center of the lower mounting bolt hole to the center of the joint pin hole is 69 mm (2.7 in). After adjustment, tighten the joint nut.

**TORQUE: 18 N·m (1.8 kgf·m, 13 lbf·ft)**





Connect the brake hose to the master cylinder with the oil bolt and new sealing washers, and tighten the oil bolt while holding the master cylinder firmly.

**TORQUE: 34 N·m (3.5 kgf·m, 25 lbf·ft)**

Install the master cylinder onto the fork leg with new mounting bolts and tighten them.

**TORQUE: 31 N·m (3.2 kgf·m, 23 lbf·ft)**

Install the pivot collar into the caliper bracket. Connect the master cylinder onto the caliper bracket with a new bolt and tighten it.

**TORQUE: 25 N·m (2.6 kgf·m, 19 lbf·ft)**

Connect the brake hose to the master cylinder with the oil bolt and new sealing washers, and tighten the oil bolt.

**TORQUE: 34 N·m (3.5 kgf·m, 25 lbf·ft)**

Install front fender B (page 13-39).

Fill and bleed the pedal brake hydraulic system (page 15-10).

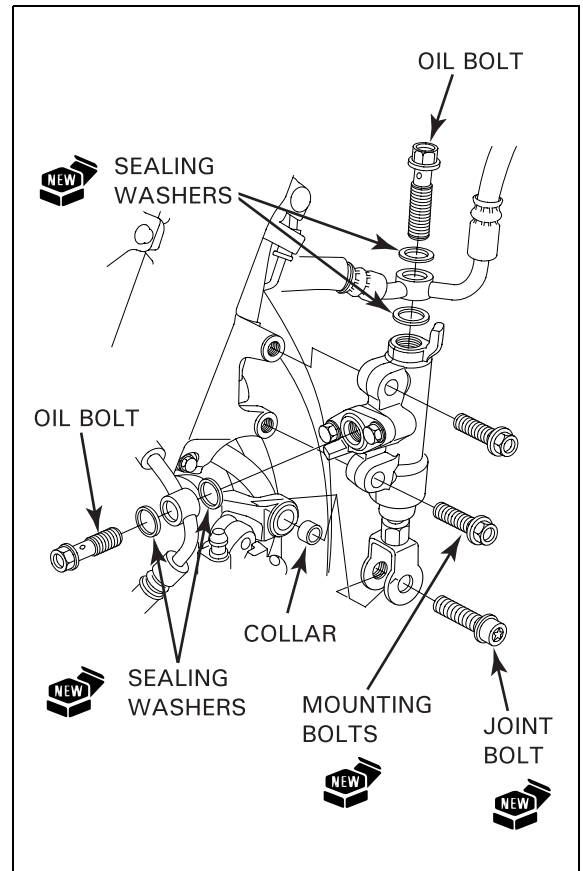

## FRONT BRAKE CALIPER

### REMOVAL

Drain the brake fluid from the lever and pedal brake hydraulic systems (page 15-6).

### LEFT CALIPER

Remove the brake pads (page 15-13).

Disconnect the brake hoses from the brake caliper by removing the oil bolts and sealing washers.



## BRAKE SYSTEM (Standard)

Remove the two mounting bolts (lower pivot and upper joint bolts) and brake caliper.  
Remove the pivot collars from the fork and caliper bracket.

Check the pivot bearings and dust seals in the fork leg for wear or damage.  
For pivot bearing replacement, see page 13-23.

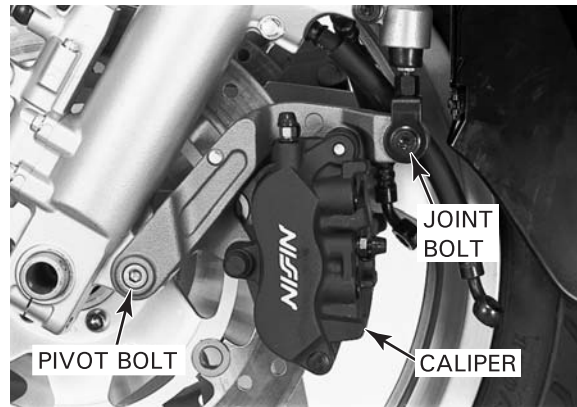

### RIGHT CALIPER

Remove the brake pads (page 15-13).

Disconnect the brake hoses from the brake caliper by removing the oil bolts and sealing washers.

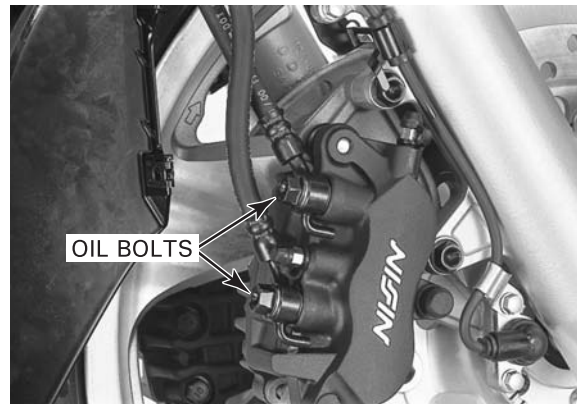

*ABS model only:* Remove the following:

- Being careful not to damage the speed sensor and sensor wire.*
- bolt and wire clamp from fork leg
  - two bolts, clamp and wheel speed sensor from caliper bracket

Remove the two mounting bolts and brake caliper.

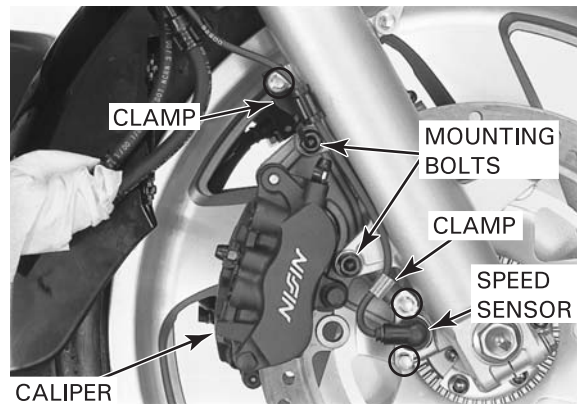

### DISASSEMBLY

Remove the following:

- caliper bracket
- boots
- pad spring

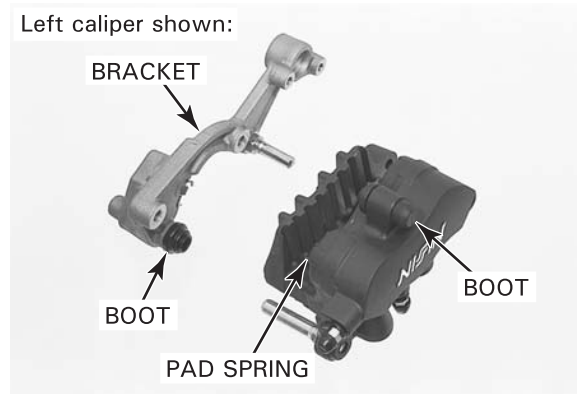

- assembly bolts
- caliper body B

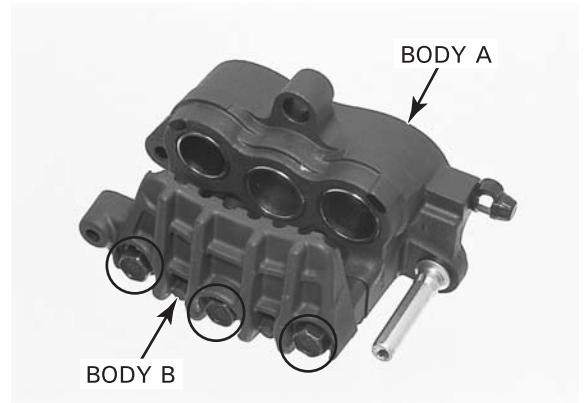

Place a shop towel over the pistons.

*Do not use high pressure air or bring the nozzle too close to the inlet.*

Position the caliper body with the piston facing down and apply small squirts of air pressure to the fluid inlets to remove the pistons.



*Be careful not to damage the piston sliding surface.*

Push the dust and piston seals in and lift them out.

Clean the seal grooves, caliper cylinders and pistons with clean brake fluid.

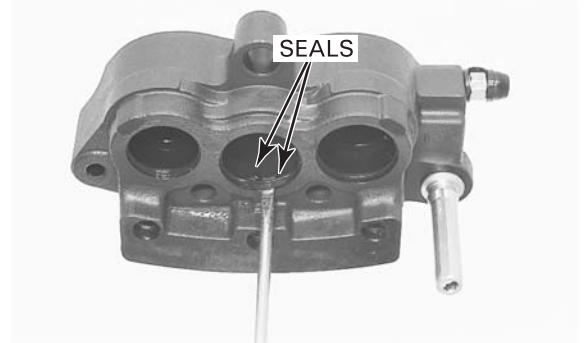

### INSPECTION

Check the caliper cylinders and pistons for scoring, scratches or damage.

Measure the caliper cylinder I.D.

#### SERVICE LIMITS:

**Left caliper: Upper/lower: 22.71 mm (0.894 in)  
Center: 27.06 mm (1.065 in)**

**Right caliper: Upper/center: 25.46 mm (1.002 in)  
Lower: 22.71 mm (0.894 in)**



## BRAKE SYSTEM (Standard)

Measure the caliper piston O.D.

### SERVICE LIMITS:

#### Left caliper:

Upper/lower: 22.56 mm (0.888 in)

Center: 26.91 mm (1.059 in)

#### Right caliper:

Upper/center: 25.31 mm (0.996 in)

Lower: 22.56 mm (0.888 in)



## ASSEMBLY

### RIGHT CALIPER

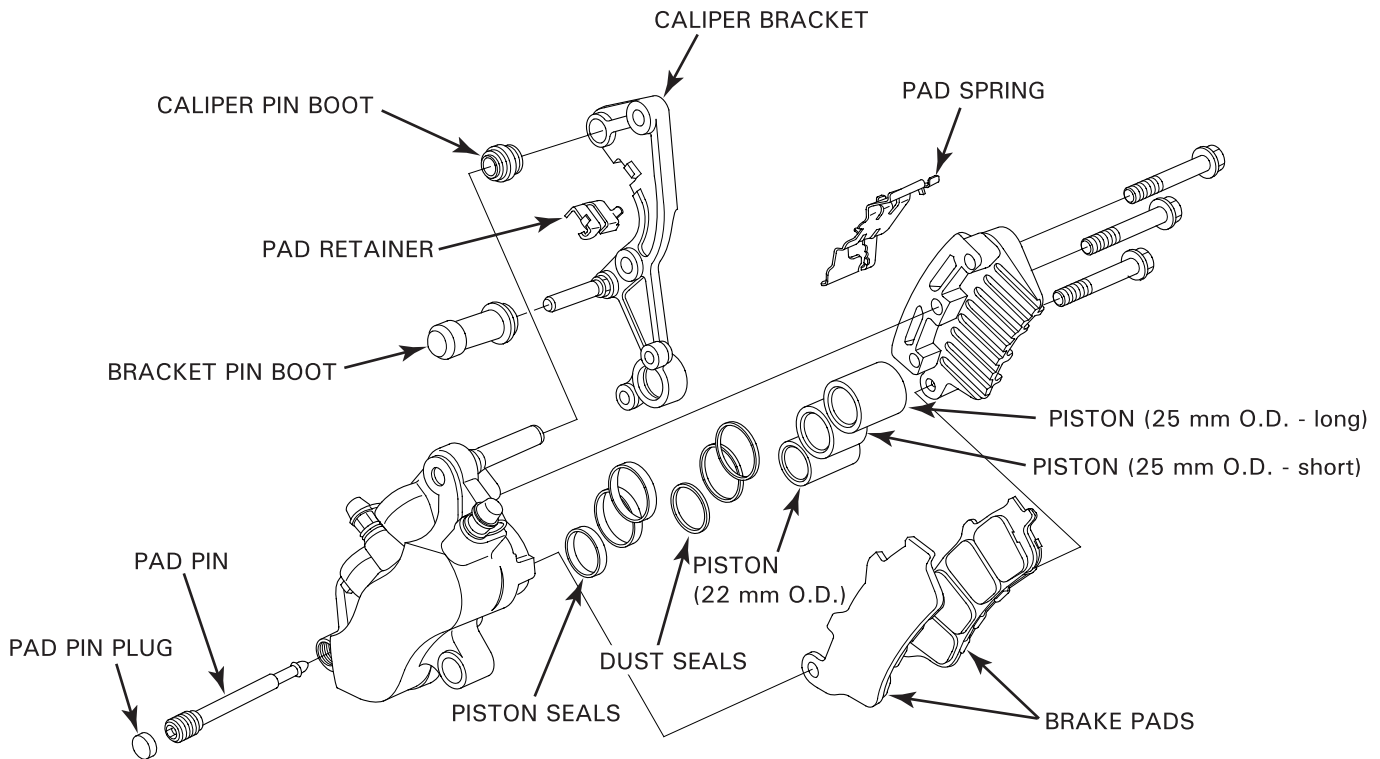

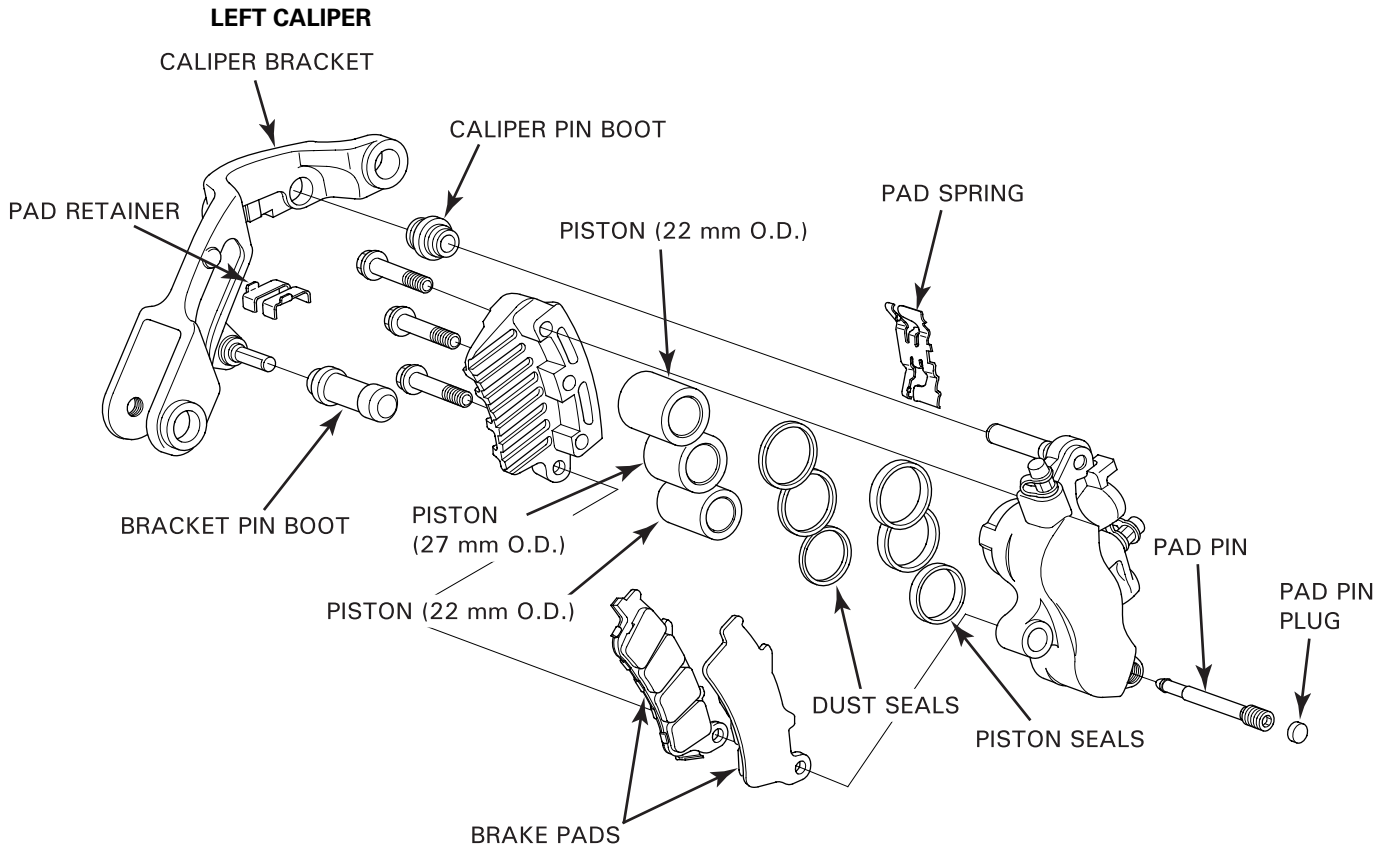

Coat new piston and dust seals with clean brake fluid and install them into their correct seal grooves in the caliper.

Coat the caliper pistons with clean brake fluid and install them into their correct caliper cylinders with the opening toward the pads.

Left caliper shown:

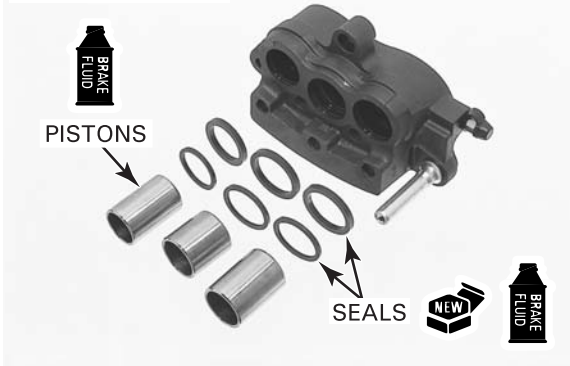

Assemble the caliper body halves with new assembly bolts and tighten them.

**TORQUE: 32 N·m (3.3 kgf·m, 24 lbf·ft)**



## BRAKE SYSTEM (Standard)

Install the pad spring onto the caliper body properly as shown (page 15-37).

Check the caliper and bracket pin boots and replace them if they are hard, deteriorated or damaged. Install the boots into the caliper and bracket.

Apply silicone grease to the inside of the boots and install the caliper bracket over the caliper body.

*Tighten the pad pin after installing the caliper onto the fork leg.*

Install the brake pads (page 15-13).

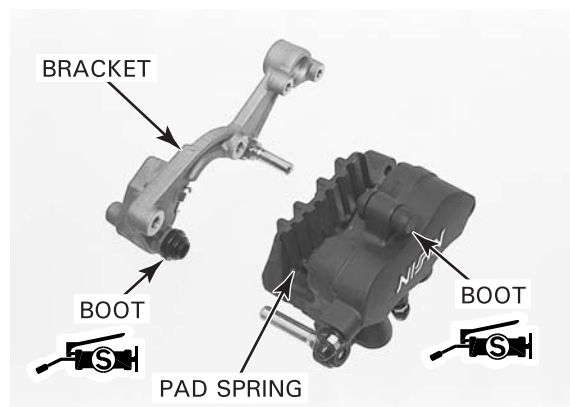

## INSTALLATION

### RIGHT CALIPER

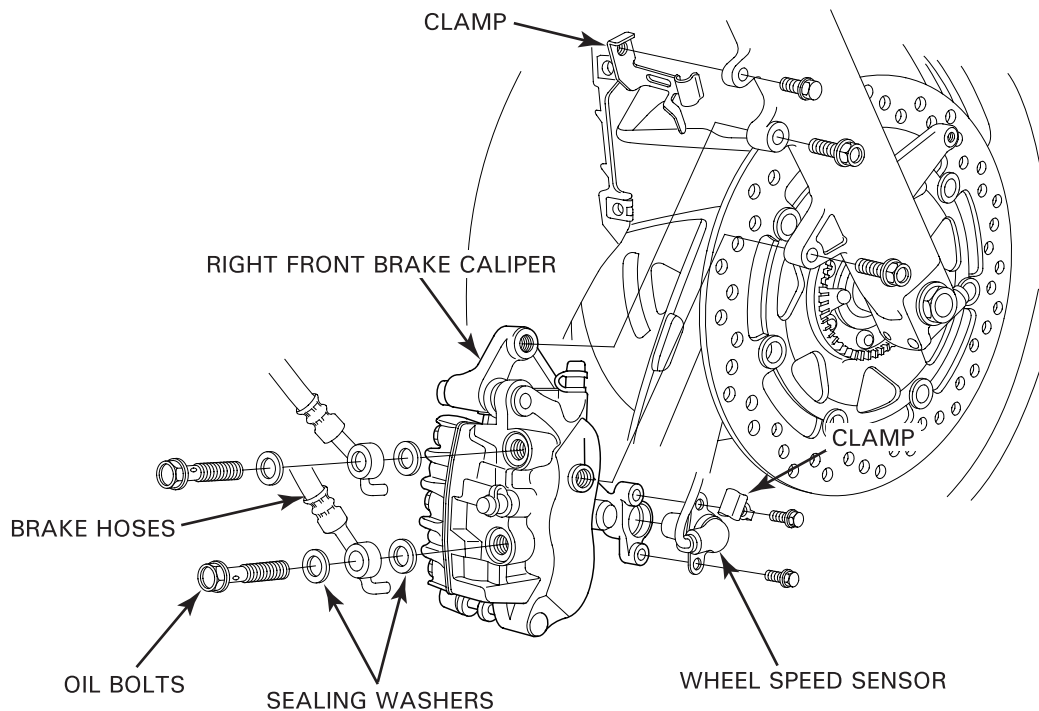

Install the right brake caliper so the disc is positioned between the pads, being careful not to damage the pads.

Install new mounting bolts and tighten them.

**TORQUE: 31 N·m (3.2 kgf·m, 23 lbf·ft)**

Install the wheel speed sensor with the wire clamp and tighten the bolts.

**TORQUE: 12 N·m (1.2 kgf·m, 9 lbf·ft)**

Install the wire clamp onto the fork leg and tighten the bolt.

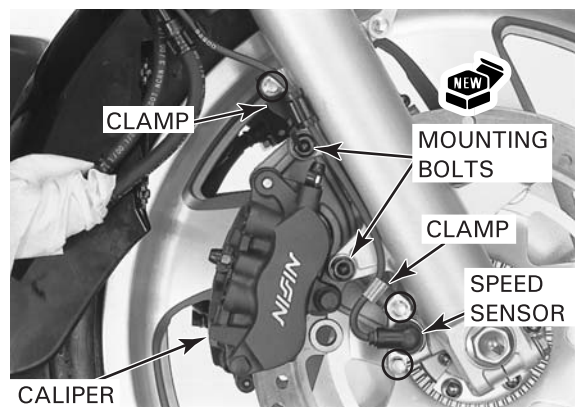



Route the brake hoses properly (page 1-23). Connect the brake hoses to the caliper with the oil bolts and new sealing washers, and tighten the oil bolts.

**TORQUE: 34 N·m (3.5 kgf·m, 25 lbf·ft)**

Tighten the pad pin and install the pad pin plug.

**TORQUE: 18 N·m (1.8 kgf·m, 13 lbf·ft)**

*ABS model only:* Perform the speed sensor air gap inspection (page 16-29).

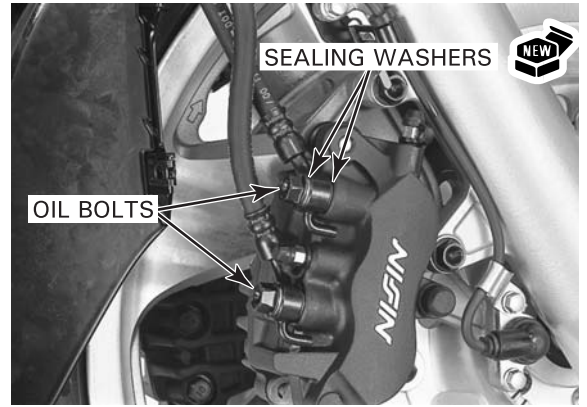

**LEFT CALIPER**

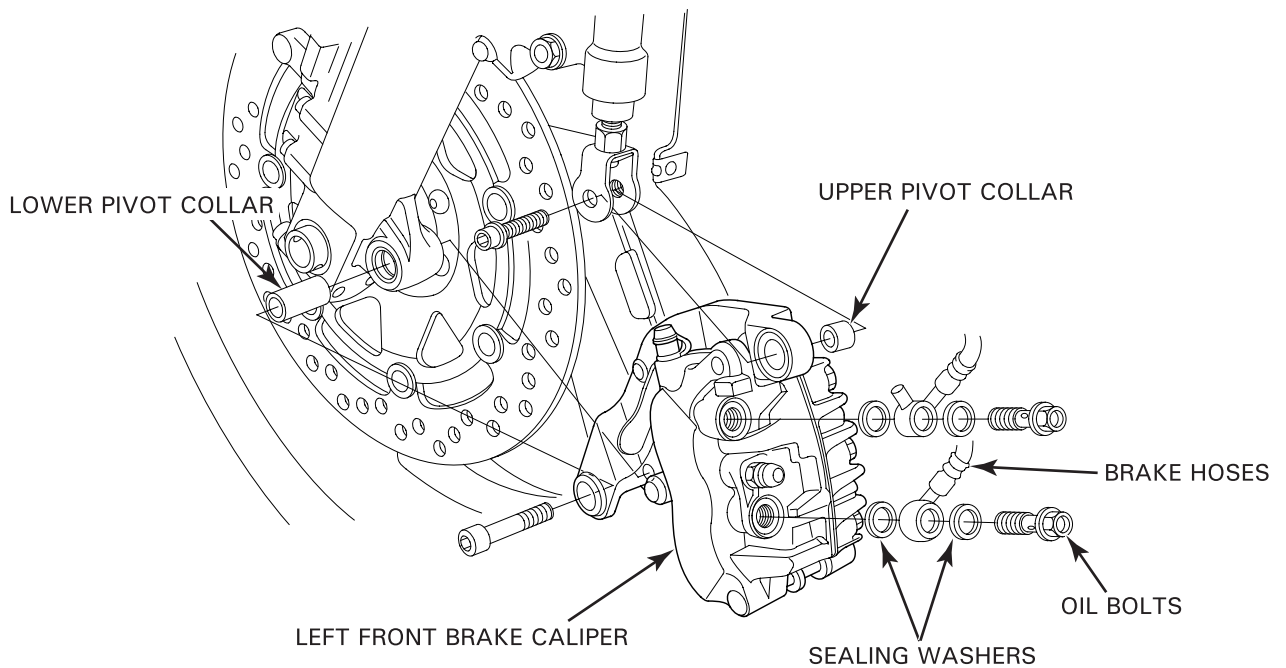

Apply grease to the lower pivot bearing and dust seal lips, and to the outer surface of the upper pivot collar.

Install the pivot collars into the fork and caliper bracket.

Install the left brake caliper so the disc is positioned between the pads, being careful not to damage the pads.

Install new mounting bolts (lower pivot and upper joint bolts) and tighten them.

**TORQUE: Pivot bolt: 31 N·m (3.2 kgf·m, 23 lbf·ft)**  
**Joint bolt: 25 N·m (2.6 kgf·m, 19 lbf·ft)**

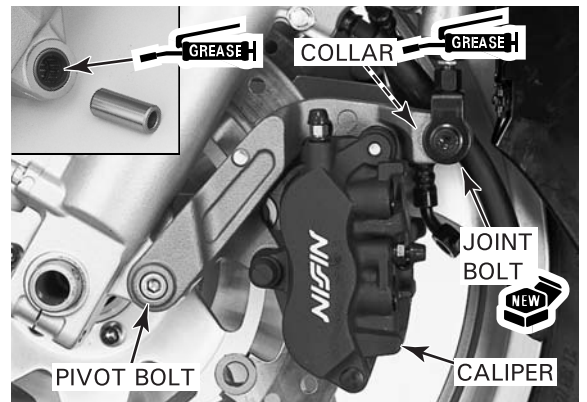

## BRAKE SYSTEM (Standard)

Route the brake hoses properly (page 1-23).

Connect the brake hoses to the caliper with the oil bolts and new sealing washers, and tighten the oil bolts.

**TORQUE: 34 N·m (3.5 kgf·m, 25 lbf·ft)**

Tighten the pad pin and install the pad pin plug.

**TORQUE: 18 N·m (1.8 kgf·m, 13 lbf·ft)**

Fill and bleed the lever and pedal brake hydraulic systems (page 15-8 and 15-11).



## REAR BRAKE CALIPER

### DISASSEMBLY

Remove the rear wheel (page 14-14).

Drain the brake fluid from the pedal brake hydraulic system (page 15-6).

Remove the brake pads (page 15-13).

Disconnect the brake hoses from the brake caliper by removing the oil bolts and sealing washers.

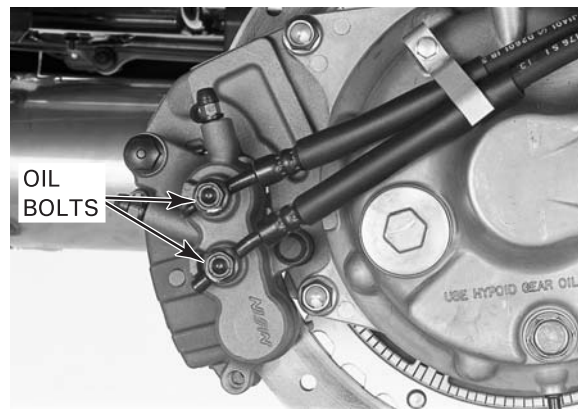

Remove the two mounting bolts and brake caliper.

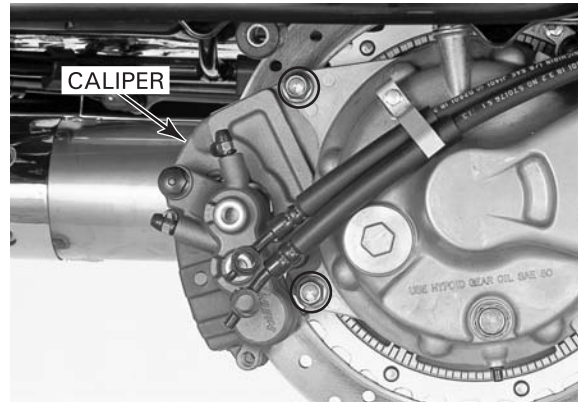

Remove the following:

- caliper bracket
- boots
- pad spring

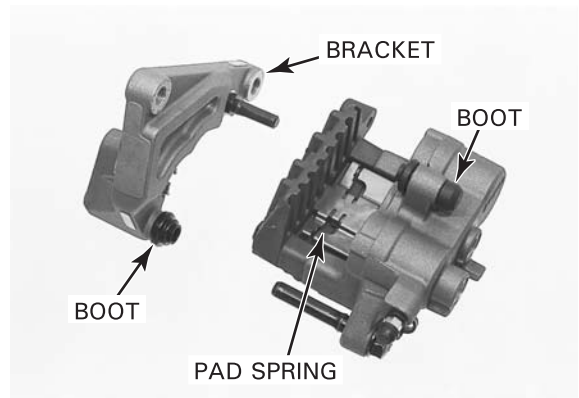

**BRAKE SYSTEM (Standard)**

- assembly bolts
- caliper body B

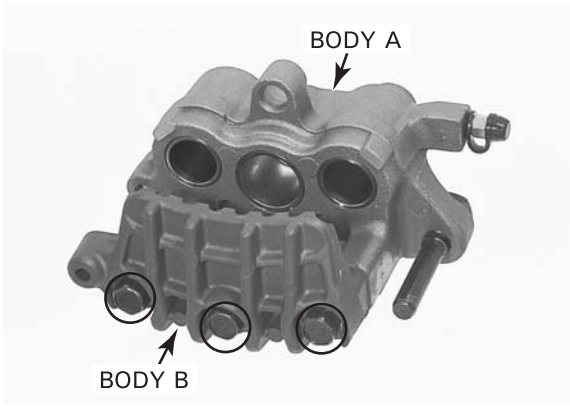

Place a shop towel over the pistons.  
Position the caliper body with the pistons facing down and apply small squirts of air pressure to the fluid inlets to remove the pistons.



Push the dust and piston seals in and lift them out.  
Clean the seal grooves, caliper cylinders and pistons with clean brake fluid.

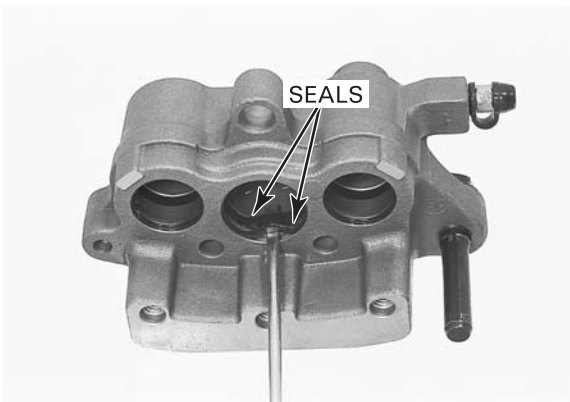

**INSPECTION**

Check the caliper cylinders and pistons for scoring, scratches or damage.

Measure the caliper cylinder I.D.

**SERVICE LIMITS: Upper/lower: 22.71 mm (0.894 in)  
Center: 27.06 mm (1.065 in)**



## BRAKE SYSTEM (Standard)

Measure the caliper piston O.D.

**SERVICE LIMITS:** Upper/lower: 22.56 mm (0.888 in)  
Center: 26.91 mm (1.059 in)



### ASSEMBLY

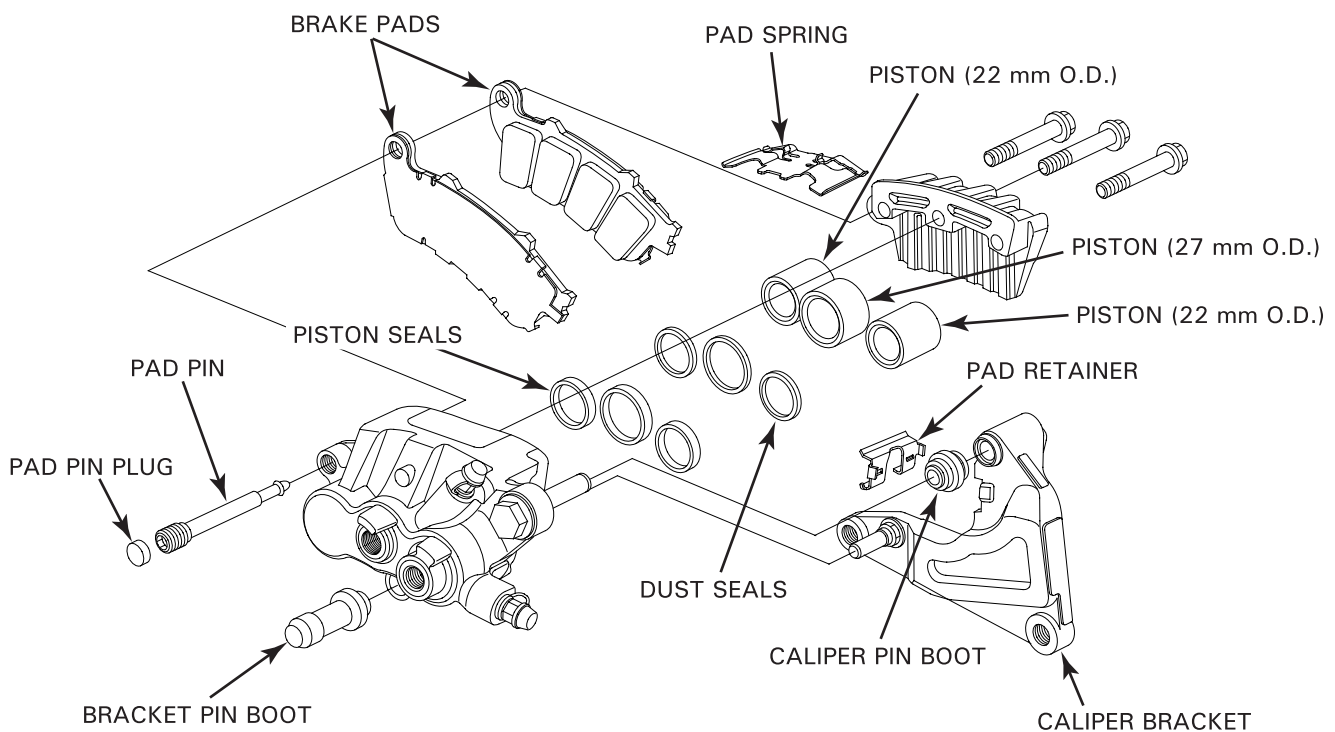

Coat new piston and dust seals with clean brake fluid and install them in the seal grooves in the caliper.

Coat the caliper pistons with clean brake fluid and install them into the caliper cylinders with the opening toward the pads.

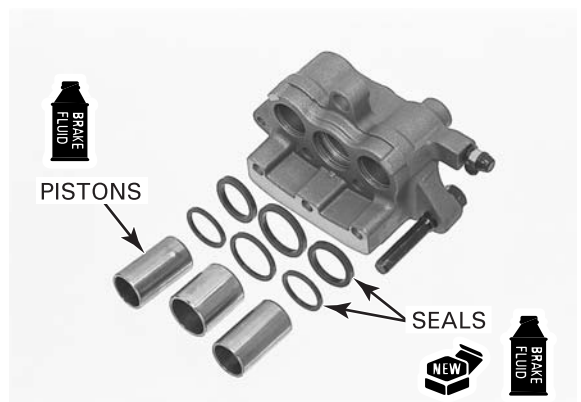

Assemble the caliper body halves with new assembly bolts and tighten them.

**TORQUE: 32 N·m (3.3 kgf·m, 24 lbf·ft)**

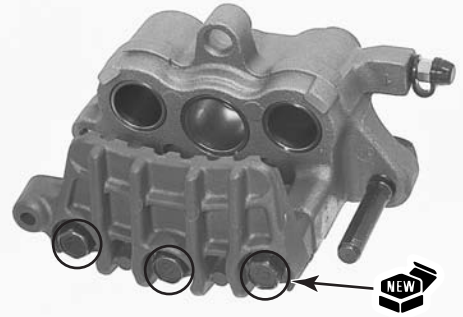

Install the pad spring onto the caliper body properly as shown.

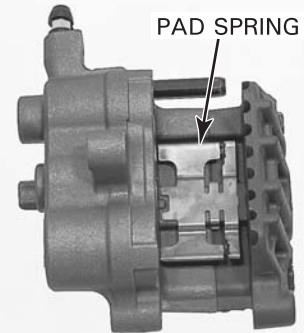

Check the caliper and bracket pin boots and replace them if they are hard, deteriorated or damaged.

Install the boots into the caliper and bracket.

Apply silicone grease to the inside of the boots and install the caliper bracket over the caliper body.

Install the brake pads (page 15-13).

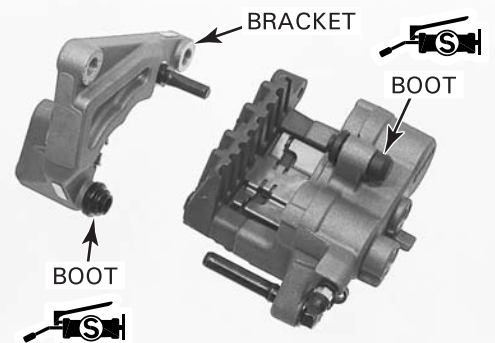

Install the brake caliper so the disc is positioned between the pads, being careful not to damage the pads.

Install new mounting bolts and tighten them.

**TORQUE: 45 N·m (4.6 kgf·m, 33 lbf·ft)**

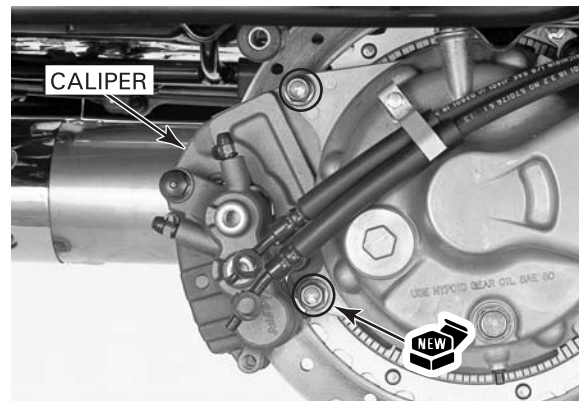



## BRAKE SYSTEM (Standard)

Connect the brake hoses to the caliper with the oil bolts and new sealing washers as shown, and tighten the oil bolts.

**TORQUE: 34 N·m (3.5 kgf·m, 25 lbf·ft)**

Tighten the pad pin and install the pad pin plug.

**TORQUE: 18 N·m (1.8 kgf·m, 13 lbf·ft)**

Fill and bleed the pedal brake hydraulic system (page 15-11).

Install the rear wheel (page 14-14).

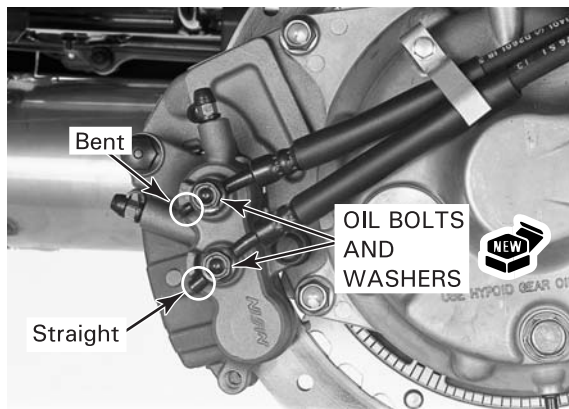

## DELAY VALVE

### REMOVAL

Drain the brake fluid from the brake pedal hydraulic system (page 15-6).

*When removing the oil bolt and joint nut, cover the ends of the hoses and pipe to prevent contamination.*

Remove the following:

- clips
- oil bolts, sealing washers and brake hoses
- bolt and 3-way joint
- brake pipe (by loosening joint nut, being careful not to scratch the fender)
- mounting bolts (8 mm head and 10 mm head; fender bolt)
- delay valve

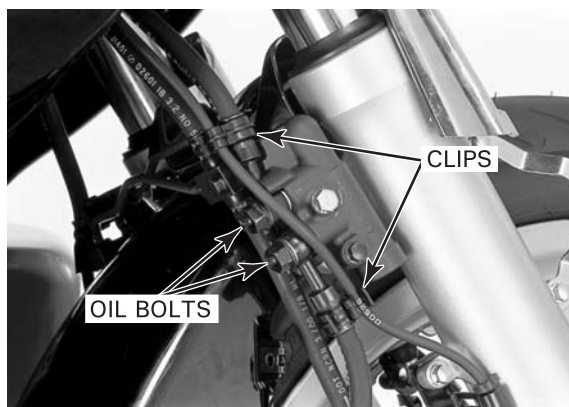

### INSTALLATION

*Route the speed sensor wire properly (page 1-23).*

Install the delay valve onto the fork leg and tighten the mounting bolts.

**TORQUE: 12 N·m (1.2 kgf·m, 9 lbf·ft)**

Apply brake fluid to the joint nut threads on the brake pipe.

Connect the brake pipe by tightening the joint nut.

**TORQUE: 17 N·m (1.7 kgf·m, 12 lbf·ft)**

Install the 3-way joint and tighten the bolt.

**TORQUE: 12 N·m (1.2 kgf·m, 9 lbf·ft)**

Connect the brake hoses with the oil bolts and new sealing washers, and tighten the oil bolts.

**TORQUE: 34 N·m (3.5 kgf·m, 25 lbf·ft)**

Secure the speed sensor wire with the clips.

Fill and bleed the pedal brake hydraulic system (page 15-10).

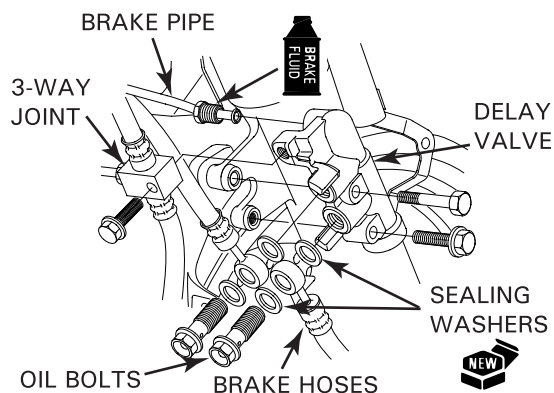
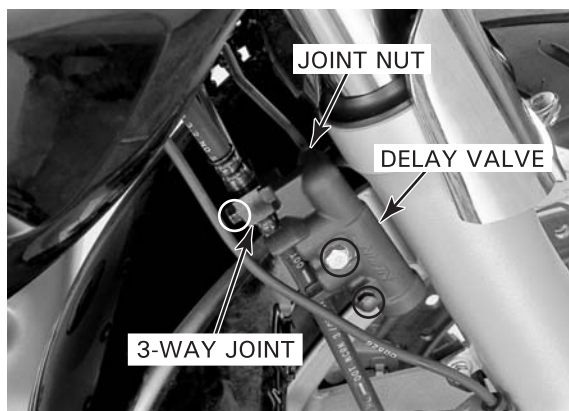



## PROPORTIONAL CONTROL VALVE (PCV)

### REMOVAL

Remove the left radiator (page 6-10).

Drain the brake fluid from the pedal brake hydraulic system (page 15-6).

*When removing the joint nut, cover the ends of the brake pipes to prevent brake fluid leakage.*

Loosen the joint nuts to disconnect the brake pipes from the PCV.

Remove the two mounting bolts and the PCV.

### INSTALLATION

Install the PCV and tighten the bolts.

**TORQUE: 12 N·m (1.2 kgf·m, 9 lbf·ft)**

Apply brake fluid to the joint nut threads on the brake pipes.

Connect the brake pipes by tightening the joint nuts.

**TORQUE: 17 N·m (1.7 kgf·m, 12 lbf·ft)**

Fill and bleed the pedal brake hydraulic system (page 15-11).

Install the left radiator (page 6-15).

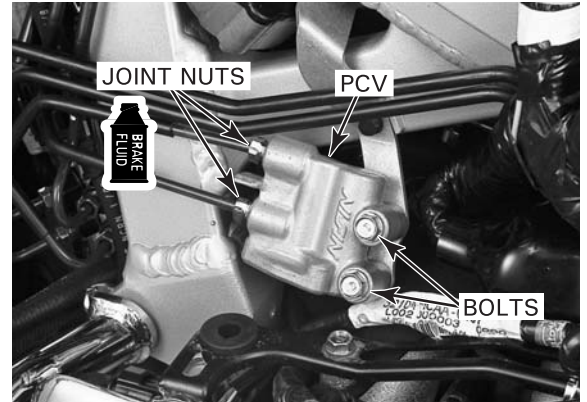

---

**MEMO**

---

# 16. BRAKE SYSTEM (ABS)

---

SYSTEM LOCATION.....	16-2	BEFORE TROUBLESHOOTING.....	16-8
SERVICE INFORMATION .....	16-3	TROUBLESHOOTING.....	16-10
SYSTEM WIRING CONNECTIONS/ LOCATIONS .....	16-4	WHEEL SPEED SENSOR.....	16-29
BEFORE STARTING TROUBLESHOOTING .....	16-5	ABS MODULATOR.....	16-31

## BRAKE SYSTEM (ABS)

### SYSTEM LOCATION

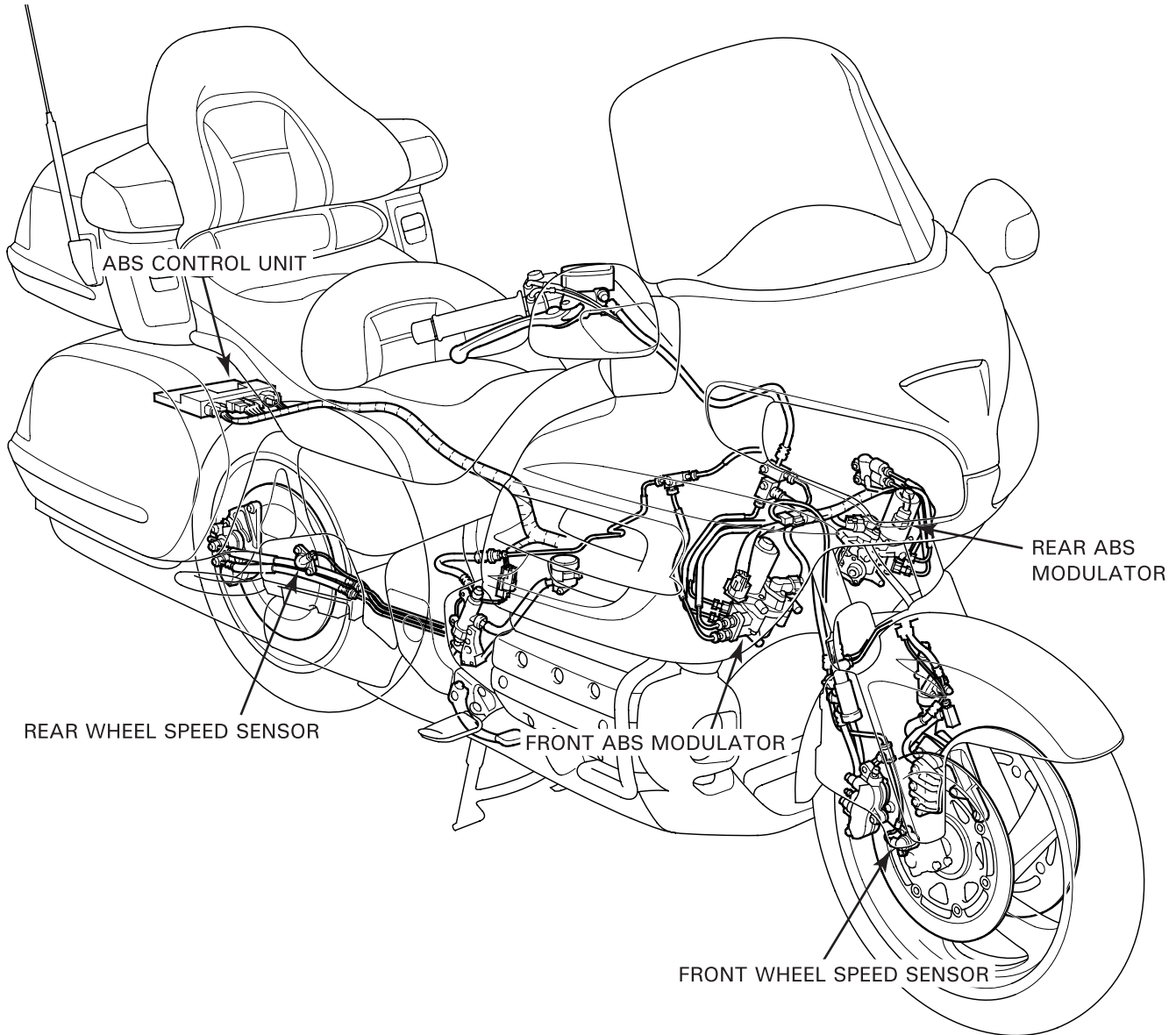

---

**SERVICE INFORMATION****GENERAL**

- This section (15-B) covers service of the Anti-lock Brake System (ABS). For other service (conventional brake) of the brake system, see section 15-A.
- When the ABS control unit detects a problem, it stops the ABS function and switches back to the conventional brake operation, and the ABS indicator blinks or it stays on. Take care during the test ride.
- Troubles not resulting from a faulty ABS (e.g., brake disc squeak, unevenly worn brake pad) cannot be recognized by the ABS diagnosis system.
- Read "Before Starting Troubleshooting" carefully, inspect and troubleshoot the ABS system according to the Diagnostic Troubleshooting Flow Chart. Observe each step of the procedures one by one. Write down the problem code and probable faulty part before starting diagnosis and troubleshooting.
- After troubleshooting, erase the problem code and perform the pre-start self-diagnosis to be sure that the ABS indicator is operating normally.
- Be careful not to damage the wheel speed sensor and pulser ring when removing and installing the wheel or speed sensor.
- When the wheel speed sensor and/or pulser ring is replaced, check the clearance (air gap) between both components.
- The ABS control unit (ECU) may be damaged if dropped. Also if a connector is disconnected when current is flowing, the excessive voltage may damage the ECU. Always turn off the ignition switch before servicing.
- Do not disassemble the ABS modulator. Replace the modulator as an assembly when it is faulty.
- Refer to section 22 for circuit diagram of ABS.
- The following color codes are used throughout this section.

Bu: Blue	G: Green	Lg: Light Green	R: Red
Bl: Black	Gr: Gray	O: Orange	W: White
Br: Brown	Lb: Light Blue	P: Pink	Y: Yellow

**TORQUE VALUES**

Brake pipe joint nut	17 N·m (1.7 kgf·m, 12 lbf·ft)	Apply brake fluid to the threads.
Wheel speed sensor bolt	12 N·m (1.2 kgf·m, 9 lbf·ft)	
Modulator mounting bolt	12 N·m (1.2 kgf·m, 9 lbf·ft)	
Ignition coil/modulator stay bolt	12 N·m (1.2 kgf·m, 9 lbf·ft)	
Modulator brake pipe joint bolt	34 N·m (3.5 kgf·m, 25 lbf·ft)	

# BRAKE SYSTEM (ABS)

## SYSTEM WIRING CONNECTIONS/LOCATIONS

Refer to page 16-5 for the parts that must be removed for service.

For example: REAR MODULATOR CONTROL MOTOR 2P ← Electric component  
- Center inner fairing (page 2-6) ← The part that must be removed for service

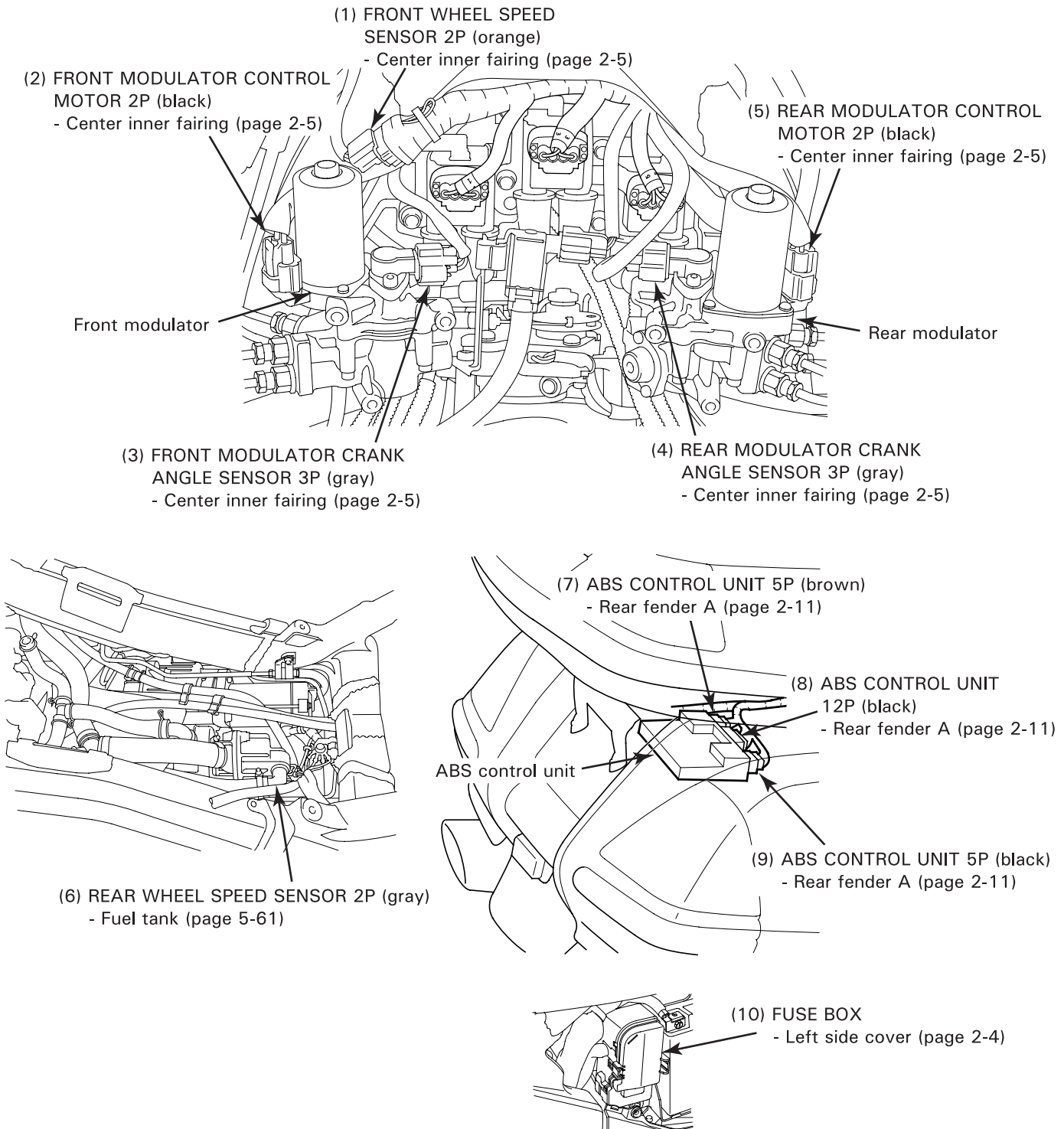



# BEFORE STARTING TROUBLESHOOTING

## SUMMARY OF ABS PRE-START SELF-DIAGNOSIS SYSTEM

The ABS pre-start self-diagnosis system diagnoses the electrical system as well as the operating status of the modulator. When there is any abnormality, the problem and the problematic part can be detected by outputting the problem code.

When the vehicle speed is approximately 10 km/h (6 mph) or more, the wheel speed sensor signal is sent to the ABS control unit (ECU), then the ABS pre-start self-diagnosis system operates the control motor on the modulator, checks the crank angle condition with the ABS control unit and thus detects whether the modulator operation is normal, and it completes the pre-start self-diagnosis.

When the ABS is normal, the ABS indicator goes off just after a road speed of 10 km/h (6 mph) indicating that the diagnosis is completed.

If a problem is detected, the ABS indicator blinks or comes on and stays on to notify the rider of the problem. The self-diagnosis is also made while the motorcycle is running, and the indicator blinks when a problem is detected.

When the indicator blinks, the cause of the problem can be identified by retrieving the problem code, follow the specified retrieval procedure (page 16-6).

Pre-start self-diagnosis when normal:

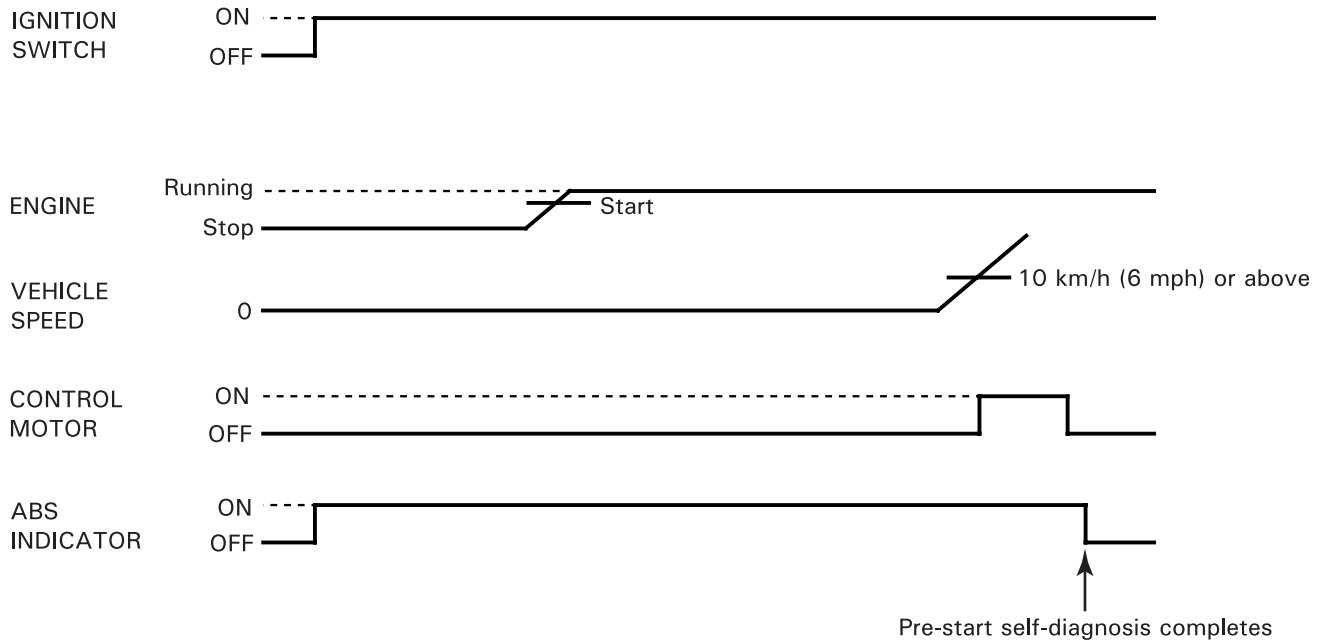

### PRE-START SELF-DIAGNOSIS PROCEDURE (Daily check)

1. Turn the ignition switch to "ON."
2. Make sure the ABS indicator comes on.
3. Start the engine.
4. Ride the motorcycle and increase the vehicle speed to approximately 10 km/h (6 mph) (pre-start self-diagnosis completed).
5. The ABS is normal if the ABS indicator goes off.

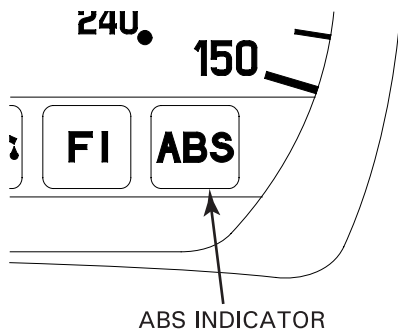

## BRAKE SYSTEM (ABS)

### RETRIEVAL/ERASURE OF PROBLEM CODE

#### NOTE:

- After retrieval, the ABS indicator indicates the problem code by blinking a specified number of times.
- The problem code is not erased by turning the ignition switch to "OFF" while the problem code is being output. Note that turning the ignition switch to "ON" again does not indicate the problem code. To show the problem code again, repeat the problem code retrieval procedures from the beginning.
- The ABS control unit stores up to two problem codes and indicates the latest problem code first, and then the earlier code alternately. When the two problem codes are indicated, begin diagnostic troubleshooting, beginning with the code that was indicated first.
- Be sure to make a note of the retrieval problem code(s).
- After diagnostic troubleshooting, erase the problem code(s) and perform the pre-start self-diagnosis to be sure that there is no problem in the ABS indicator (indicator is operating normally).

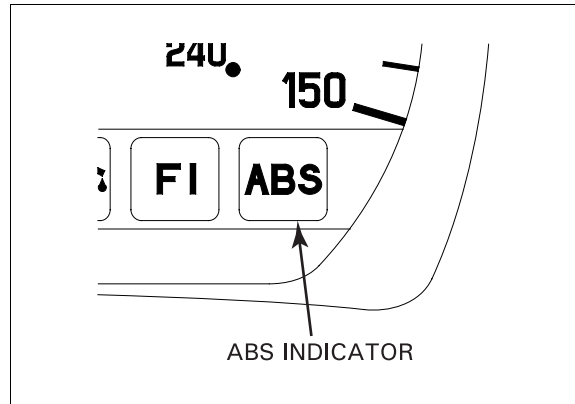

#### RETRIEVAL:

1. Remove the No. 3 and 4 control motor fuses with the ignition switch turned to "OFF" to be sure that each fuse is not burned out.

#### NOTE:

- If either fuse is burned out, perform the troubleshooting of problem code "4" (No. 3 fuse) or "5" (No. 4 fuse) without installing the fuse.
2. Turn the ignition switch to "ON." The ABS indicator should come on.
  3. Wait for 5 seconds and the ABS indicator goes off.
  4. Install either the No. 3 or the No. 4 fuse immediately after the ABS indicator is off (within 3 seconds).
  5. The problem code is indicated by the number of times the ABS indicator blinks.

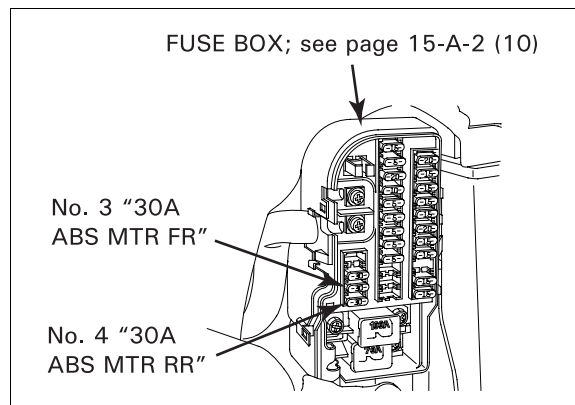

#### TO ERASE THE PROBLEM CODE:

1. Install the remaining fuse (No. 3 or No.4) while the problem code is being indicated (i.e., the ABS indicator is blinking).
2. When code erasure is complete, the ABS indicator stays on.

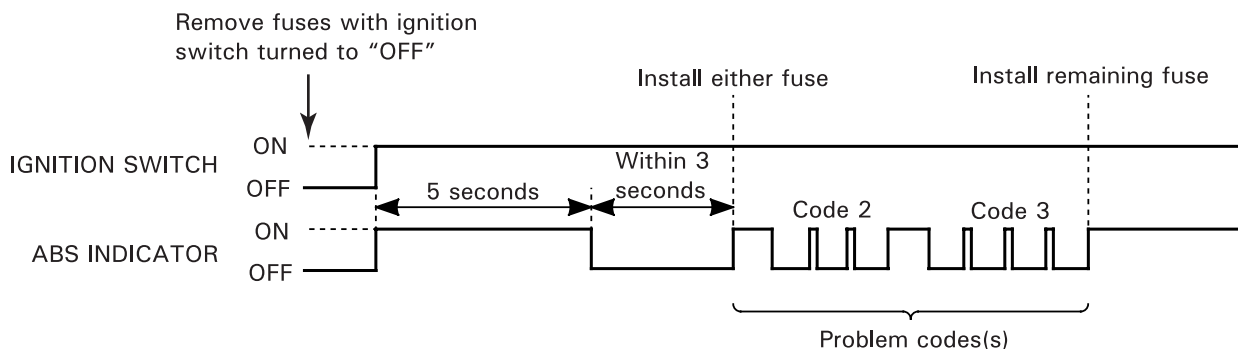

**PROBLEM CODE INDICATION PATTERN**

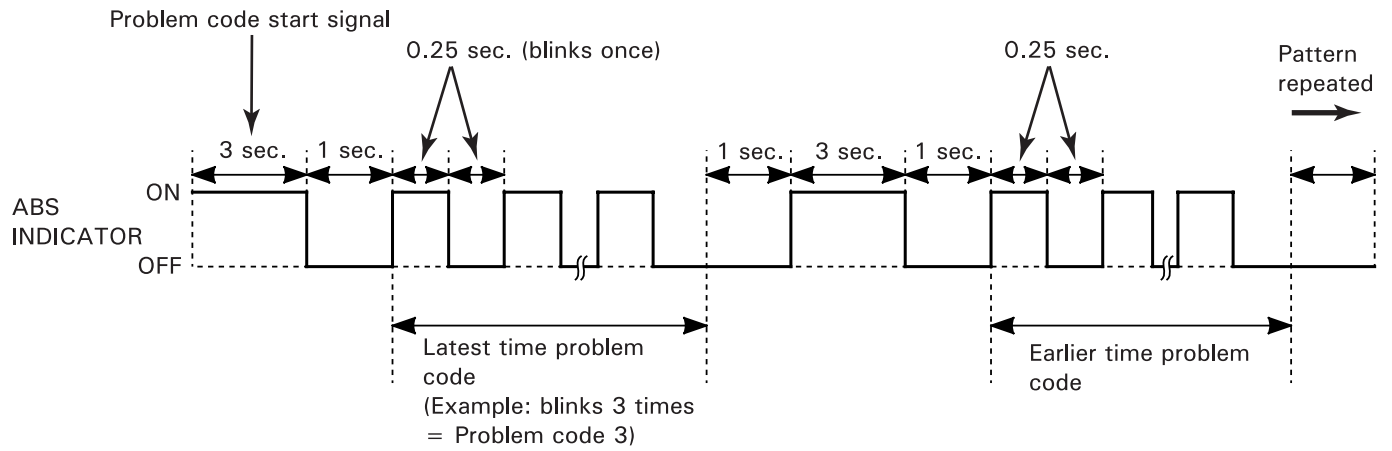

**When the problem code is not stored:**

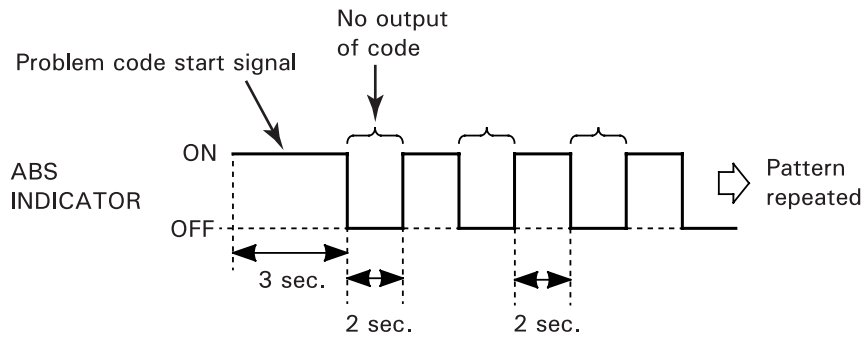

## BRAKE SYSTEM (ABS)

# BEFORE TROUBLESHOOTING

## SYMPTOM-TO-SYSTEM CHART

NOTE:

- Before performing any ABS troubleshooting, check the pre-start self-diagnosis (page 16-5).

Problem code	Check part and system	Probable faulty part														Reference page						
		Fuse		Modulator				Wheel speed sensor		Pulsar ring		Power circuit (charging)	Wire harness	ABS control unit	ABS indicator		Tire		Wheel		Riding conditions (NOTE)	
		ABS main	Modulator control motor	Control motor		Crank angle sensor		Front	Rear	Front	Rear						Front	Rear	Front	Rear		Front
				Front	Rear	Front	Rear					Front	Rear	Front	Rear							
2	Front wheel speed sensor system																				16-10	
3	Rear wheel speed sensor system																					16-12
4	Front control motor system		○		○		○															16-14
5	Rear control motor system			○		○																16-16
6	Front crank angle sensor system						○															16-18
7	Rear crank angle sensor system							○														16-21
8	Front control circuit		○		○		○		○								○		○		○	16-10
9	Rear control circuit			○		○		○		○								○		○	○	16-12
10	Front relay circuit		○		○		○															16-23
11	Rear relay circuit			○		○		○														16-24
12	Front motor driver circuit		○		○																	16-25
13	Rear motor driver circuit			○		○																16-25
14	Power circuit											○	○	○								16-26
—	Problems not detected by ABS control unit	○										○	○	○	○							16-27

- The ABS indicator might blink in the following cases:
  - The motorcycle has continuously run on bumpy roads.
  - After riding (after the pre-start self-diagnosis), the engine was kept running and the rear wheel turning (for more than 30 seconds) with the motorcycle placed on the center stand.
  - The ABS control unit is disrupted by extremely powerful radio waves (electromagnetic interference). This is a temporary failure. erase the problem code and perform the pre-start self-diagnosis. The ABS is normal if the ABS indicator goes off.

---

**DIAGNOSTIC TROUBLESHOOTING FLOW CHART****NOTICE**

*Be careful not to damage the wheel speed sensor and pulser ring when servicing.*

- The connector number (number in parenthesis) indicates the connector location as shown on page 16-4. All connector diagrams in the flow charts are viewed from the terminal side.
- Perform inspection with the ignition switch turned to "OFF," unless otherwise specified.
- Use a fully charged battery. Do not diagnose with a charger connected to the battery.
- When the ABS control unit or modulator is detected to be faulty, recheck the wire harness and connector connections closely before replacing it.
- After troubleshooting, erase the problem code and perform the pre-start self-diagnosis to be sure that the ABS indicator is operating normally.
- The ABS indicator might blink in the following cases. Correct the faulty part.
  - Incorrect tire pressure.
  - Tires not recommended for the motorcycle were installed (incorrect tire size).
  - Deformation of the wheel or tire.
- The ABS indicator might blink while riding under the following conditions. Erase the problem code and perform the pre-start self-diagnosis. The ABS is normal if the indicator goes off. Ask the rider for the riding conditions in detail when the motorcycle is brought in for inspection.
  - The motorcycle has continuously run on bumpy roads.
  - After riding (after the pre-start self-diagnosis), the engine was kept running and the rear wheel turning (for more than 30 seconds) with the motorcycle placed on the center stand.
- If the pulser ring or speed sensor is replaced, perform the air gap inspection page 16-29.

# TROUBLESHOOTING

### **Problem Code 2 and 8: Front wheel speed sensor system and ABS control unit**

#### **1. Wheel Pulser Air Gap Inspection**

Check the area around the front wheel speed sensor.

Measure the air gap between the speed sensor and pulser ring (page 16-29).

##### ***Is the gap correct?***

**NO** – Check each part for deformation and looseness and correct accordingly. Check air gap again.

**YES** – GO TO STEP 2.

#### **2. Wheel Pulser Magnetic Deposits Inspection**

Check to see if there are iron or other magnetic deposits between the pulser ring and speed sensor.

##### ***Are there magnetic deposits between the pulser ring and speed sensor?***

**NO** – GO TO STEP 3.

**YES** – Remove any deposits.

#### **3. Speed Sensor/Pulser Ring Fit Inspection**

Check installation condition of the pulser ring and speed sensor for looseness.

##### ***Does pulser ring and speed sensor fit properly?***

**NO** – Install properly or replace the faulty part.

**YES** – GO TO STEP 4.

#### **4. Speed Sensor/Pulser Ring Damage Inspection**

Check the pulser ring for deformation or damage (e.g., chipped teeth) and the speed sensor tip for damage.

##### ***Is pulser ring or speed sensor deformed or damaged?***

**NO** – GO TO STEP 5.

**YES** – Replace the faulty part.

#### **5. ABS Indicator Function Inspection**

Retrieve the problem code and erase it. Turn ignition switch to "ON" (do not operate the ignition switch after erasing the problem code), turn the front wheel by hand (vehicle speed: approximately 4 km/h [2.5 mph] or above) and check the ABS indicator.

##### ***Is the indicator blinking?***

**YES** – Normal (temporary failure).  
The ABS control unit has been disrupted by an extremely powerful radio wave. Check the connector and wire harness of the speed sensor system for loose connection.

**NO** – GO TO STEP 6.



**6. Speed Sensor Line Short Circuit Inspection at ABS Control Unit**

Disconnect the ABS control unit 12P connector (8). Check for continuity between the Black/white or Green/orange terminal of the connector (8) and ground.

**Is there continuity?**

- NO** - GO TO STEP 8.
- YES** - GO TO STEP 7.

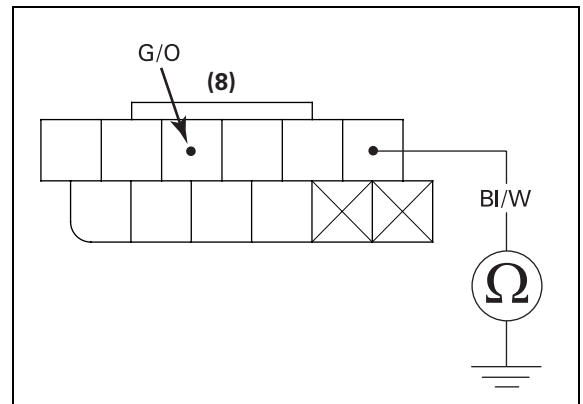

**7. Speed Sensor Line Short Circuit Inspection at Sensor Connector**

Disconnect the front wheel speed sensor connector (1). Check for continuity between either terminal of the sensor side connector (1) and ground in the same manner as the previous step.

**Is there continuity?**

- NO** - Short circuit between the ABS control unit and speed sensor.
- YES** - Faulty front wheel speed sensor.

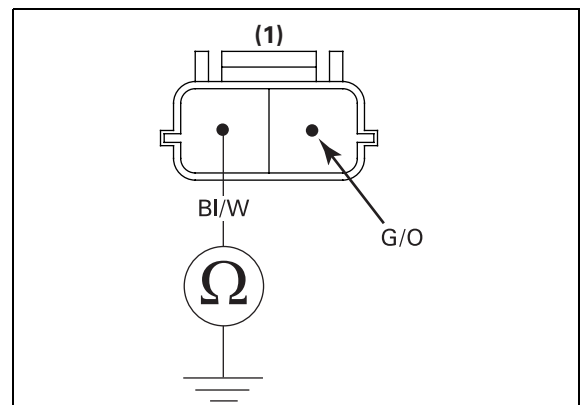

**8. Wire Harness Continuity Inspection**

Disconnect the front wheel speed sensor connector (1). Short the terminals of the connector (1) with a jumper wire. Check for continuity between the Black/white and Green/orange terminals of the connector (8).

**Is there continuity?**

- YES** - GO TO STEP 9.
- NO** - Open circuit in the wire between the ABS control unit and front wheel speed sensor.

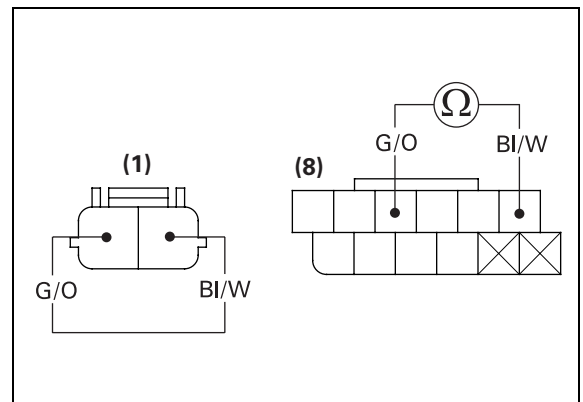

**9. Check Indicator Function Again**

Remove the front wheel speed sensor and replace it with a new one. Connect the control unit 12P connector (8). Perform the pre-start self-diagnosis and check the ABS indicator.

**Is the indicator blinking?**

- NO** - Faulty removed wheel speed sensor.
- YES** - Faulty ABS control unit.

## BRAKE SYSTEM (ABS)

---

### **Problem Code 3 and 9: Rear wheel speed sensor system and ABS control unit**

#### **1. Wheel Pulsar Air Gap Inspection**

Check the area around the rear wheel speed sensor.

Measure the air gap between the speed sensor and pulser ring (page 16-29).

##### ***Is the air gap correct?***

**NO** – Check each part for deformation and looseness and correct accordingly. Check for air gap again.

**YES** – GO TO STEP 2.

#### **2. Wheel Pulsar Magnetic Deposits Inspection**

Check between pulser ring and speed sensor for any iron or other magnetic deposits.

##### ***Magnetic deposits found?***

**NO** – GO TO STEP 3.

**YES** – Remove any deposits.

#### **3. Speed Sensor/Pulser Ring Fit Inspection**

Check installation condition of the pulser ring and speed sensor for looseness.

##### ***Did pulser ring and speed sensor have proper fit?***

**NO** – Install properly or replace the faulty part.

**YES** – GO TO STEP 4.

#### **4. Speed Sensor/Pulser Ring Damage Inspection**

Check the pulser ring for deformation or damage (e.g., chipped teeth) and the speed sensor tip for damage.

##### ***Was deformation or damage found?***

**NO** – GO TO STEP 5.

**YES** – Replace the faulty part.

#### **5. ABS Indicator Function Inspection**

Retrieve the problem code and erase it. With the ignition switch turned "ON" (do not operate the ignition switch after erasing the problem code), turn the rear wheel by hand (vehicle speed: approximately 4 km/h [2.5 mph] or above) and check the ABS indicator.

##### ***Is the indicator blinking?***

**YES** – Normal (temporary failure).  
The ABS control unit has been disrupted by an extremely powerful radio wave. Check the connector and wire harness of the speed sensor system for loose connection.

**NO** – GO TO STEP 6.

**6. Speed Sensor Line Short Circuit Inspection at ABS Control Unit**

Disconnect the ABS control unit 12P connector (8). Check for continuity between the Black/orange or Blue/yellow terminal of the connector (8) and ground.

*Is there continuity?*

**NO (NORMAL)** – GO TO STEP 8.

**YES** – GO TO STEP 7.

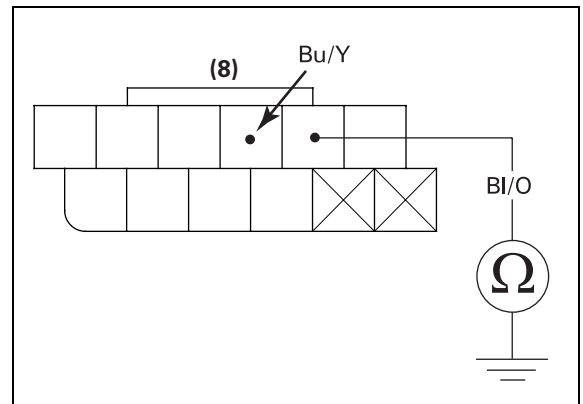

**7. Speed Sensor Line Short Circuit Inspection at Sensor Connector**

Disconnect the rear wheel speed sensor connector (6). Check for continuity between either terminal of the sensor side connector (6) and ground in the same manner as the previous step.

*Is there continuity?*

**NO** – Short circuit in the wire between the ABS control unit and speed sensor.

**YES** – Faulty rear wheel speed sensor.

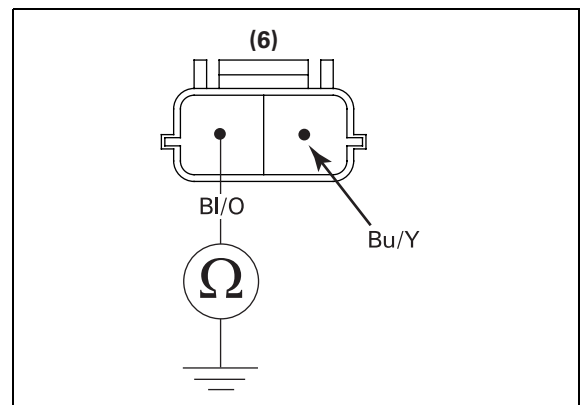

**8. Wire Harness Continuity Inspection**

Disconnect the rear wheel speed sensor connector (6). Short the terminals of the connector (6) with a jumper wire. Check for continuity between the Black/orange and Blue/yellow terminals of the connector (8).

*Is there continuity?*

**NO** – Open circuit in the wire between the ABS control unit and speed sensor.

**YES** – GO TO STEP 9.

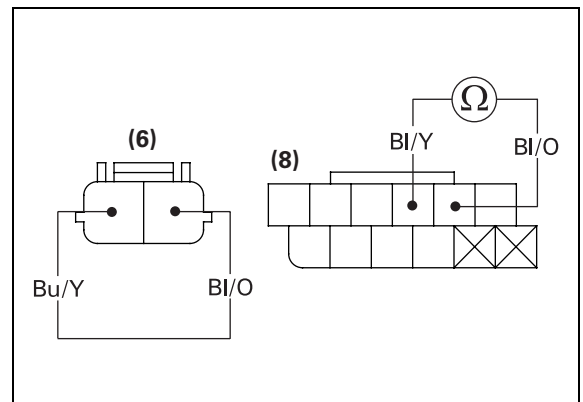

**9. Check Indicator Function Again**

Remove the rear wheel speed sensor and replace it with a new one. Connect the control unit 12P connector (8). Perform the pre-start self-diagnosis and check the ABS indicator.

*Is indicator blinking?*

**NO** – Faulty removed wheel speed sensor.

**YES** – Faulty ABS control unit.

## BRAKE SYSTEM (ABS)

### Problem Code 4: Front modulator control motor system

#### 1. Motor Fuse No. 3 Inspection

Check the front control motor fuse (No. 3; 30A).

**Is the fuse blown?**

**NO** – GO TO STEP 3.

**YES** – GO TO STEP 2.

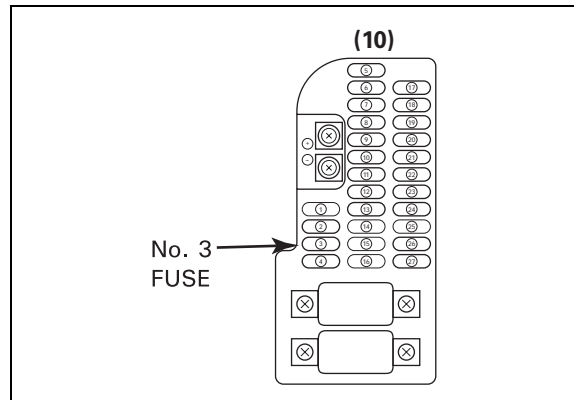

#### 2. Short Circuit Inspection Between Fuse Box and ABS Control Unit

Disconnect the ABS control unit 5P connector (9). Check for continuity between the Red/blue terminal of the connector (9) and ground with the No. 3 fuse removed.

**Is there continuity?**

**NO** – Temporary failure (install a spare fuse and check again).

**YES** – Short circuit in the wire between the fuse box and ABS control unit.

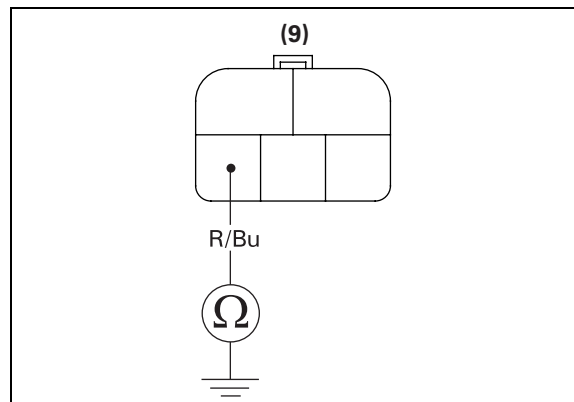

#### 3. ABS Indicator Function Inspection

Retrieve the problem code and erase it. Perform the pre-start self-diagnosis and check the ABS indicator.

**Is indicator blinking?**

**YES** – GO TO STEP 4.

**NO** – Normal (temporary failure). Fine foreign matter in modulator, or the ABS unit has been disrupted by and extremely powerful radio wave. Check the connector and wire harness for loose connection.

#### 4. ABS Control Unit Battery Voltage Inspection

Disconnect the ABS control unit 5P connector (9). Measure the voltage between the Red/blue terminal (+) of the connector (9) and the ground (-). There should be battery voltage at all times.

**Is there battery voltage?**

**NO** – Open circuit in the wire between the fuse box and ABS control unit.

**YES** – GO TO STEP 5.

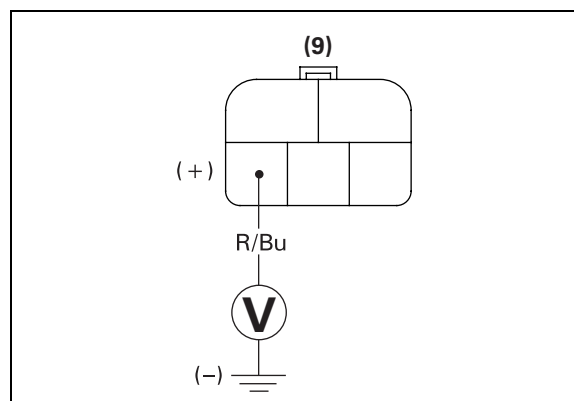

**5. Modulator Motor Ground Circuit Inspection at ABS Control Unit**

Check for continuity between the Green terminal of the connector (9) and ground.

**Is there continuity?**

- NO** - Open circuit in the Green wire (ground).
- YES** - GO TO STEP 6.

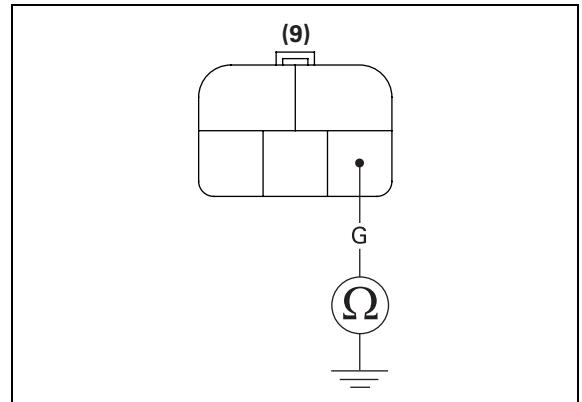

**6. Modulator Motor Short Circuit Inspection at Modulator Connector**

Disconnect the front modulator control motor connector (2). Check for continuity between the Brown/yellow terminal of the connector (2) and ground, and between the Green/yellow terminal of the connector (2) and ground.

**Is there continuity?**

- NO** - GO TO STEP 8.
- YES** - Short circuit in the wire between the ABS control unit and modulator (control motor).

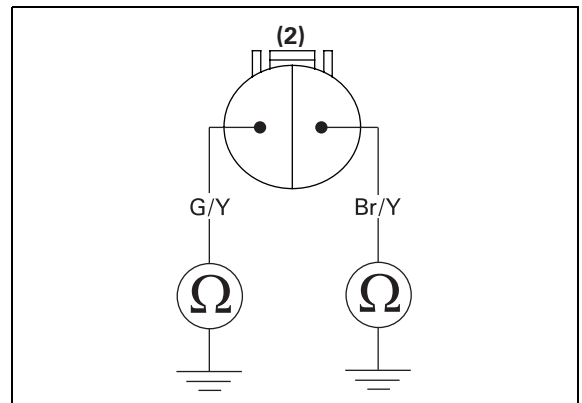

**7. Open Circuit Inspection Between ABS Control Unit and Front Modulator**

Short the Brown/yellow and Green/yellow terminal of the connector (9) with a jumper wire. Check for continuity between the Brown/yellow and Green/yellow terminals of the connector (2).

**Is there continuity?**

- YES** - GO TO STEP 8.
- NO** - Open circuit in the wire between the ABS control unit and modulator (control motor).

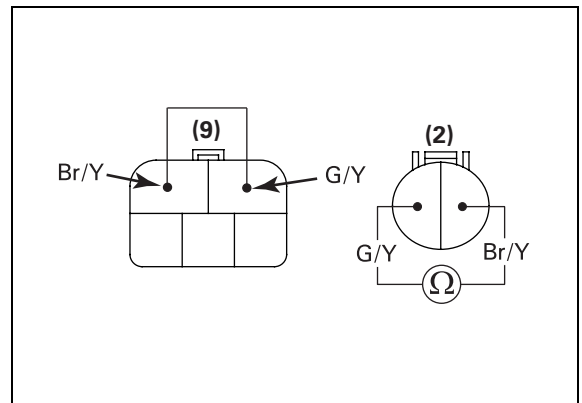

## BRAKE SYSTEM (ABS)

### 8. Modulator Motor Inspection by Removing Front and Rear Modulators

Connect the control unit 5P connector (9). Disconnect the (3), (4) and (5) connectors from the front and rear modulators. Connect the (5) and (4) connectors to the front modulator, and the (2) and (3) connectors to the rear modulator conversely. Perform the pre-start self-diagnosis and retrieve the problem code and record it.

**Is any problem code indicated?**

**CODE 4** – Faulty ABS control unit.

**CODE 5** – Faulty front modulator assembly.

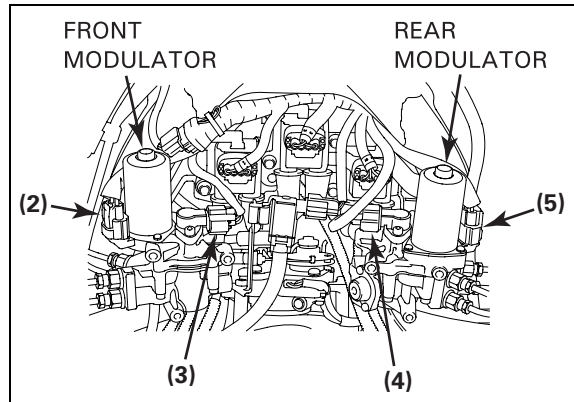

### Problem Code 5: Rear modulator control motor system

#### 1. Front Control Motor Fuse No. 4 Inspection

Check the front control motor fuse (No. 4; 30A).

**Is the fuse blown?**

**NO** – GO TO STEP 3.

**YES** – GO TO STEP 2.

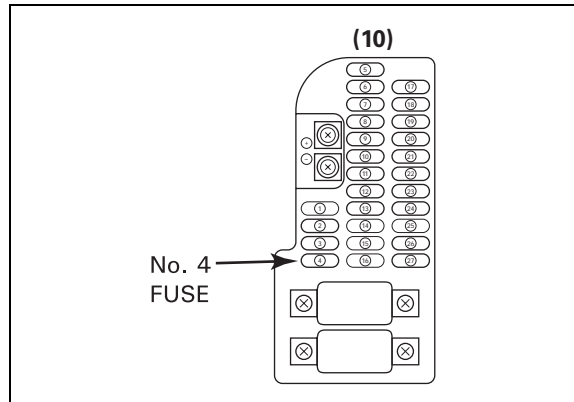

#### 2. Short Circuit Inspection Between Fuse Box and ABS Control Unit

Disconnect the ABS control unit 5P connector (7). Check for continuity between the Red/green terminal of the connector (7) and ground with the No. 4 fuse removed.

**Is there continuity?**

**YES** – Short circuit in the wire between the fuse box and ABS control.

**NO** – Temporary failure (install a spare fuse and recheck).

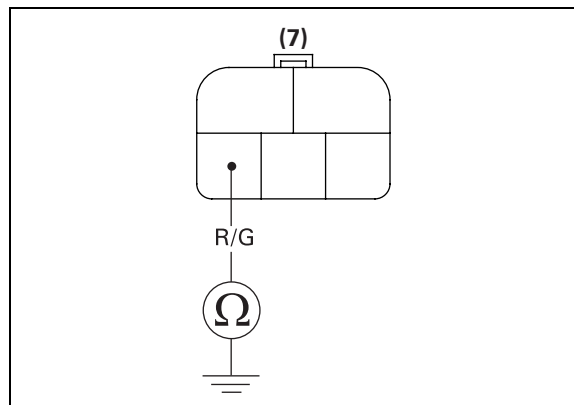

#### 3. ABS Indicator Function Inspection

Retrieve the problem code and erase it. Perform the pre-start self-diagnosis and check the ABS indicator.

**Is the indicator blinking?**

**NO** – Normal (temporary failure). Fine foreign material in modulator or the ABS control unit has been disrupted by an extremely powerful radio wave. Check the connector and wire harness for loose connection.

**YES** – GO TO STEP 4.



**4. ABS Control Unit Battery Voltage Inspection**

- Disconnect the ABS control unit 5P connector (7). Measure the voltage between the Red/green terminal (+) of the connector (7) and ground (-). There should be battery voltage at all times.

**Is there battery voltage?**

**NO** - Open circuit in the wire between the fuse box and ABS control unit.

**YES** - GO TO STEP 5.

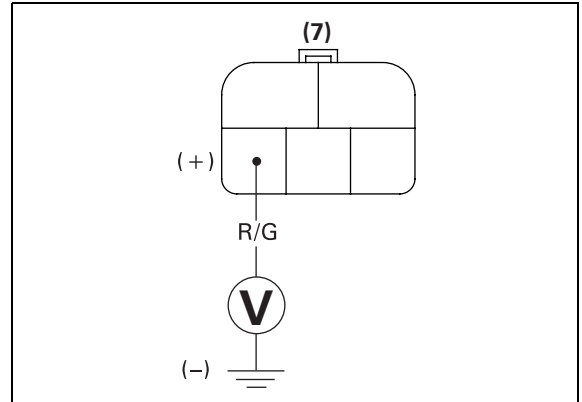

**5. Modulator Motor Ground Circuit Inspection at ABS Control Unit**

Check for continuity between the Green terminal of the connector (7) and ground.

**Is there continuity?**

**NO** - Open circuit between in the Green wire.

**YES** - GO TO STEP 6.

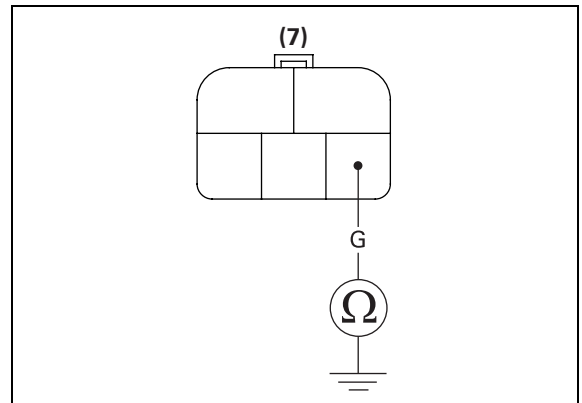

**6. Modulator Motor Short Circuit Inspection at Modulator Connector**

Disconnect the rear modulator control motor connector (5). Check for continuity between the Brown/light green terminal of the connector (5) and ground, and between the Red/black terminal of the connector (5) and ground.

**Is there continuity?**

**NO** - GO TO STEP 7.

**YES** - Short circuit in the wire between the ABS control unit and modulator (control motor).

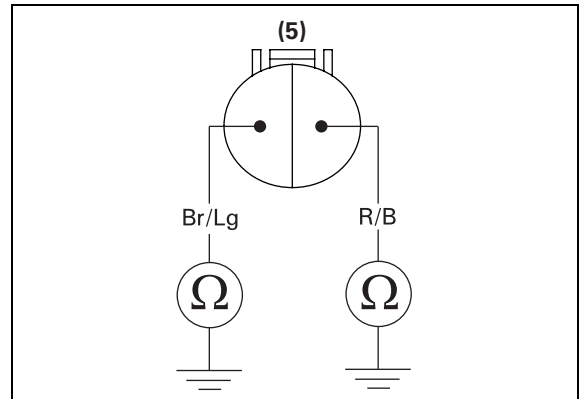

## BRAKE SYSTEM (ABS)

### 7. Wire Harness Open Circuit Inspection Between ABS Control Unit and Rear Modulator

Short the Brown/light green and Red/black terminals of the connector (7) with a jumper wire. Check for continuity between the Brown/light green and Red/black terminals of the connector (5).

#### *Is there continuity?*

**NO** – Open circuit in the wire between the ABS control unit and modulator (control motor).

**YES** – GO TO STEP 8.

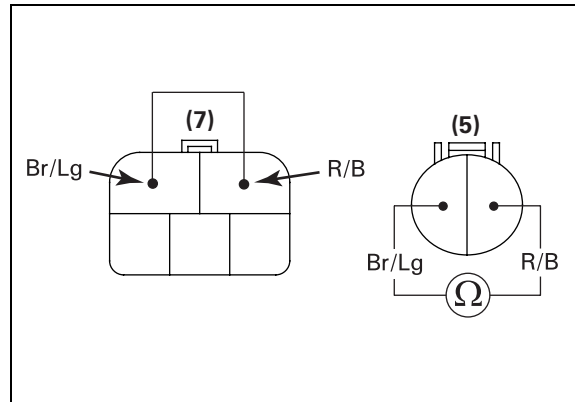

### 8. Modulator Motor Inspection by Replacing Front and Rear Modulators

Connect the control unit 5P connector (7). Disconnect the (2), (3) and (4) connectors from the front and rear modulators. Connect the (2) and (3) connectors to the rear modulator and the (5) and (4) connectors to the front modulator conversely. Perform the pre-start self-diagnosis and retrieve the problem code and record it.

#### *Is there a problem code 4 or 5?*

**CODE 4** – Faulty rear modulator assembly.

**CODE 5** – Faulty ABS control unit.

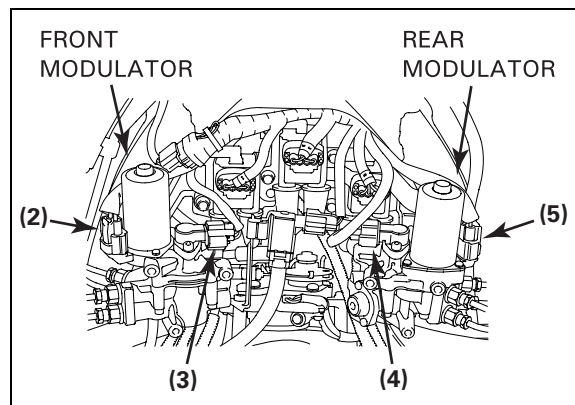

### Problem Code 6: Front modular crank angle sensor system

#### 1. ABS Indicator Checking

Turn the ignition switch "ON" and check the ABS indicator.

#### *Is the indicator blinking?*

**NO** – GO TO STEP 2.

**YES** – GO TO STEP 3.

#### 2. ABS Indicator Function Inspection

Retrieve the problem code and erase it. Perform pre-start self-diagnosis and check the ABS indicator.

#### *Is the indicator blinking?*

**NO** – Normal (temporary failure). Fine foreign material in modulator or the ABS control unit has been disrupted by an extremely powerful radio wave. Check the connector and wire harness for loose connection.

**YES** – GO TO STEP 3.

**3. Crank Angle Sensor Input Voltage Inspection**

Disconnect the front modulator crank angle sensor connector (3). Measure the voltage between the Orange/green (+) and Pink/black (-) terminals of the connector (3) with the ignition switch turned to "ON." Standard: 4.5 – 5.5V.

**Is voltage within standard range?**

**NO** – GO TO STEP 7.

**YES** – GO TO STEP 4.

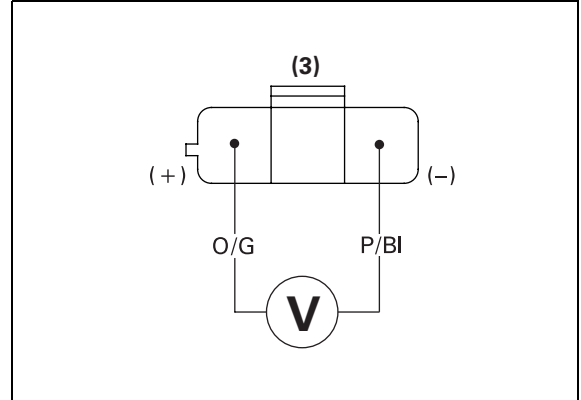

**4. Crank Angle Sensor Short Circuit Inspection at ABS Control Unit Connector**

- Disconnect the ABS control unit 12P connector (8). Check for continuity between the White/red terminal of the connector (3) and ground.

**Is there continuity?**

**NO** – GO TO STEP 5.

**YES** – Short circuit in the wire between the ABS control unit and modulator (angle sensor).

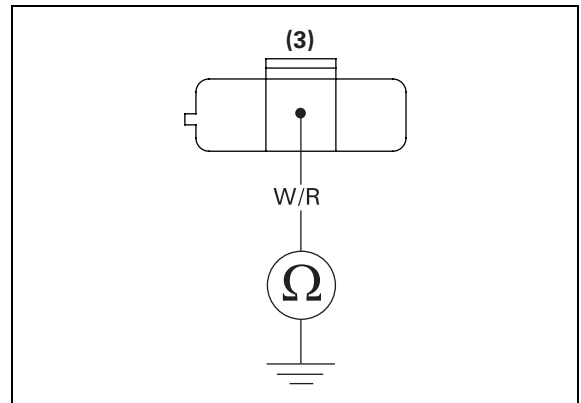

**5. Open Circuit Inspection Between ABS Control Unit and Angle Sensor Modulator**

Ground the White/red terminal of the connector (8) with a jumper wire. Check for continuity between the White/red terminal of the connector (3) and ground.

**Is there continuity?**

**NO** – Open circuit in the wire between the ABS control unit and modulator (angle sensor).

**YES** – GO TO STEP 6.

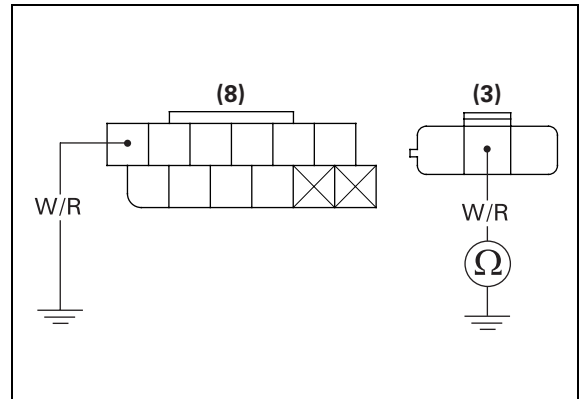

## BRAKE SYSTEM (ABS)

### 6. Modulator Inspection by Replacing the Front and Rear Modulators

Connect the control unit 12P connector (8). Disconnect the (2), (4) and (5) connectors from the front and rear modulators. Connect the (5) and (4) connectors to the front modulator, and the (2) and (3) connectors to the rear modulator conversely. Perform the pre-start self-diagnosis and retrieve the problem code, and record it.

**Is there a problem code 6 or 7?**

**CODE 6** – Faulty ABS control unit.

**CODE 7** – Faulty front modulator assembly.

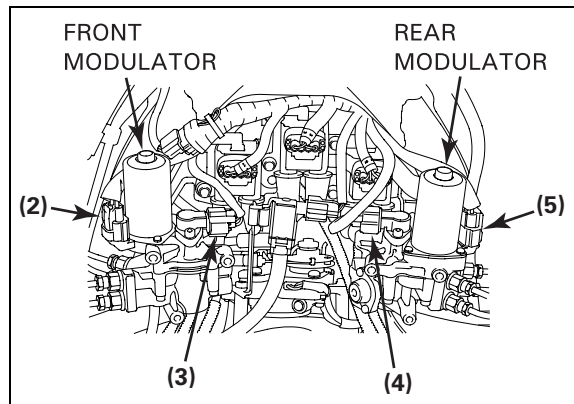

### 7. Short Circuit Inspection Between ABS Control Unit and Angle Sensor Modulator

Disconnect the ABS control unit 12P connector (8). Check for continuity between the Orange/green terminal of the connector (3) and ground, and between the Pink/black terminal of the connector (3) and ground.

**Is there continuity?**

**NO** – GO TO STEP 8.

**YES** – Short circuit in the wire between the ABS control unit and modulator (angle sensor).

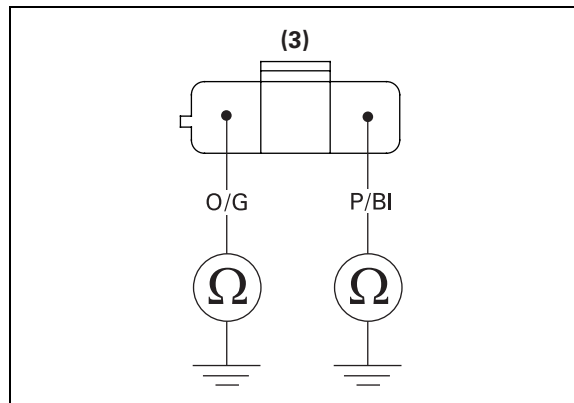

### 8. Open Circuit Inspection Between ABS Control Unit and Modulator

Short the Orange/green and Pink/black terminals of the connector (8) with a jumper wire. Check for continuity between the Orange/green and Pink/black terminals of the connector (3).

**Is there continuity?**

**NO** – Open circuit in the wire between the ABS control unit and modulator (angle sensor).

**YES** – Faulty ABS control unit.

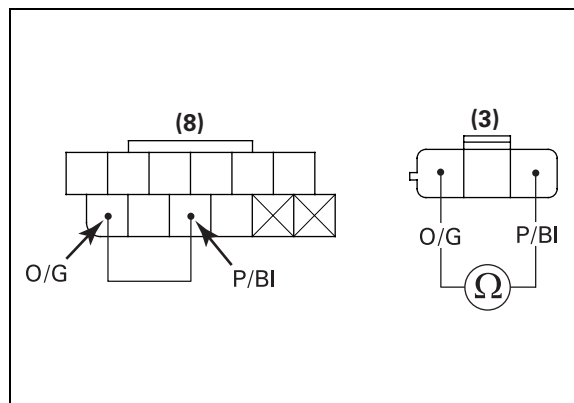

**Problem Code 7: Rear modulator crank angle sensor system**

**1. ABS Indicator Checking**

Turn the ignition switch to "ON" and check the ABS indicator.

**Is the indicator blinking?**

**NO** – GO TO STEP 2.

**YES** – GO TO STEP 3.

**2. ABS Indicator Function Inspection**

Retrieve the problem code and erase it. Perform the pre-start self-diagnosis and check the ABS indicator.

**Does indicator go off or blink?**

**GOES OFF** – Normal (temporary failure). Fine foreign material in modulator or the ABS control unit has been disrupted by an extremely powerful radio wave. Check the connector and wire harness for loose connection.

**YES** – GO TO STEP 3.

**3. Crank Angle Sensor Input Voltage Inspection**

- Disconnect the rear modulator crank angle sensor connector (4). Measure the voltage between the Orange/white (+) and Pink/white (-) terminals of the connector (4) with the ignition switch turned to "ON." Standard: 4.5 – 5.5V.

**Is voltage within standard value?**

**NO** – GO TO STEP 6.

**YES** – GO TO STEP 4.

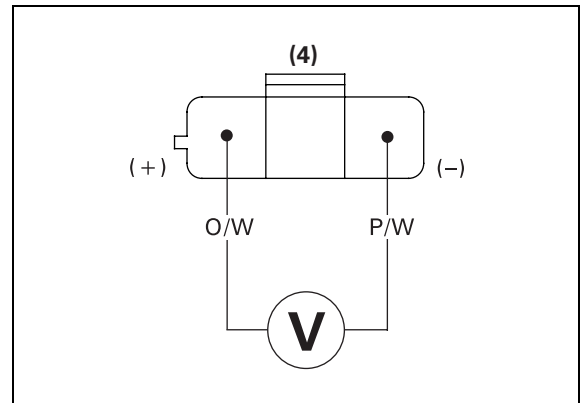

**4. Short Circuit Inspection Between ABS Control Unit and Angle Sensor Modulator**

Disconnect the ABS control unit 12P connector (8). Check for continuity between the White/blue terminal of the connector (4) and ground.

**Is there continuity?**

**NO** – GO TO STEP 5.

**YES** – Short circuit in the wire between the ABS control unit and modulator (angle sensor).

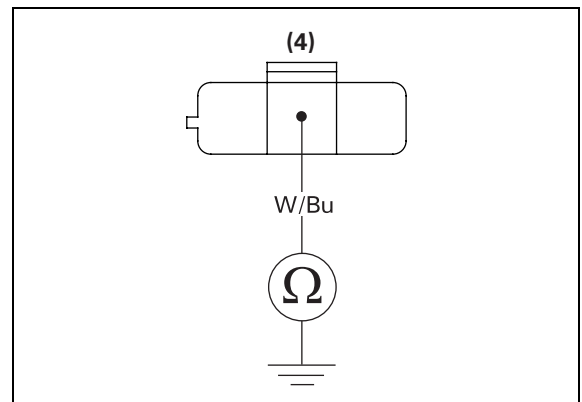

## BRAKE SYSTEM (ABS)

### 5. Open Circuit Inspection Between ABS Control Unit and Angle Sensor Modulator

Ground the White/blue terminal of the connector (8) with a jumper wire. Check for continuity between the White/blue terminal of the connector (4) and ground.

**Is there continuity?**

**NO** – Open circuit in the wire between the ABS control unit and modulator (angle sensor).

**YES** – GO TO STEP 6.

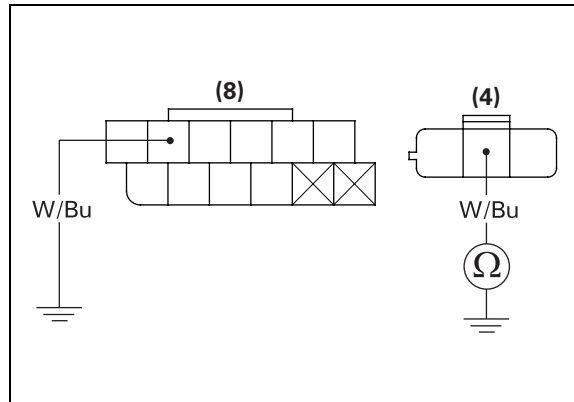

### 6. Modulator Inspection by Replacing the Front and rear Modulators

Connect the control unit 12P connector (8). Disconnect the (2), (3), and (5) connectors from the front and rear modulators. Connect the (2) and (3) connectors to the rear modulator, and the (5) and (4) connectors to the front modulator conversely. Perform the pre-start self-diagnosis and retrieve the problem code and record it.

**Is any problem code indicated?**

**CODE 6** – Faulty rear modulator assembly.

**CODE 7** – Faulty ABS control unit.

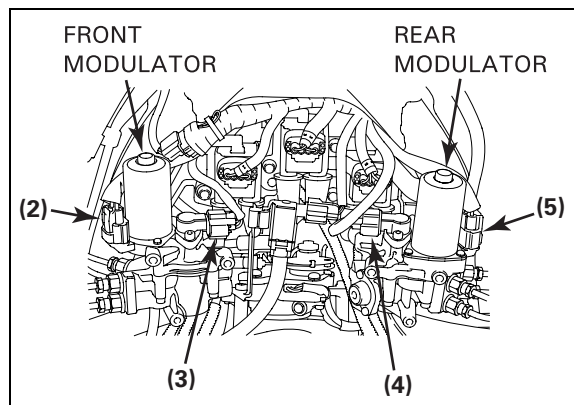

### 7. Short Circuit Inspection Between the ABS Control Unit and Angle Sensor Modulator

Disconnect the ABS control unit 12P connector (8). Check for continuity between the Orange/white terminal of the connector (4) and ground, and between the Pink/white terminal of the connector (4) and ground.

**Is there continuity?**

**NO** – GO TO STEP 8.

**YES** – Short circuit in the wire between the ABS control unit and modulator (angle sensor).

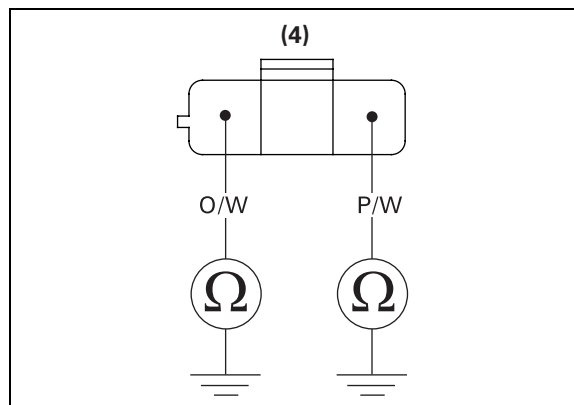



**8. Open Circuit Inspection Between ABS Control Unit and Angle Sensor Modulator or Faulty ABS Control Unit**

Short the Orange/white and Pink/white terminals of the connector (8) with a jumper wire. Check for continuity between the Orange/white and Pink/white terminals of the connector (4).

**Is there continuity?**

- NO** – Open circuit in the wire between the ABS control unit and modulator (angle sensor).
- YES** – Faulty ABS control unit.

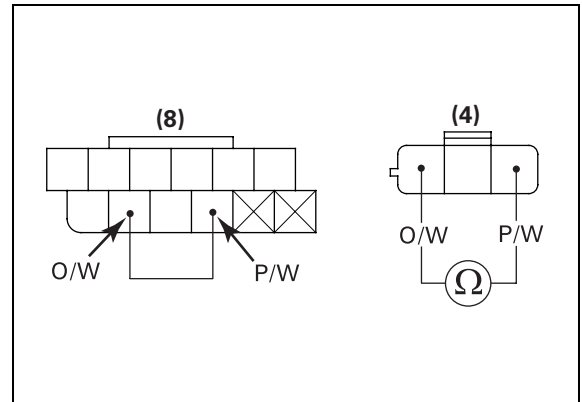

**Problem Code 10: ABS control unit (front relay circuit)**

**1. ABS Indicator Checking**

NOTE:

- The ABS indicator blinks or comes on and stays on when the ABS control unit has been disrupted by an extremely powerful radio wave (electromagnetic interference). This is just a temporary symptom. Erase the problem code and the ABS control unit is normal unless the symptom occurs again.

Turn the ignition switch to “ON” and check the ABS indicator.

**Is the indicator blinking?**

- NO** – GO TO STEP 2.
- YES** – GO TO STEP 3.

**2. ABS Indicator Function Inspection**

Retrieve the problem code and erase it. Perform the pre-start self-diagnosis and check the ABS indicator.

**Is the indicator blinking?**

- NO** – Normal (temporary failure). Fine foreign matter in modulator or the ABS control unit has been disrupted by an extremely powerful radio wave. Check the connector and wire harness for loose connection.
- YES** – GO TO STEP 3.

**3. Check Problem Code**

Retrieve the problem code and record the latest problem code.

**Is the problem code 10 or other?**

- CODE 10** – GO TO STEP 4.
- OTHER THAN CODE 10** – Diagnose at the latest problem code.

## BRAKE SYSTEM (ABS)

### 4. Modulator Inspection by Replacing the Front and Rear Modulators

Disconnect the (2), (3), (4) and (5) connectors from the front and rear modulators. Connect the (5) and (4) connectors to the front modulator, and the (2) and (3) connectors to the rear modulator conversely. Perform the pre-start self-diagnosis and retrieve the problem code, and record it.

**Is any problem code indicated?**

**CODE 10** – Faulty ABS control unit.

**CODE 11** – Faulty front modulator assembly.

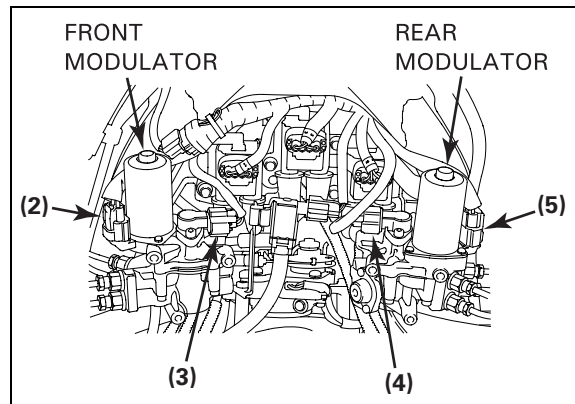

### Problem Code 11: ABS control unit (rear relay circuit)

#### 1. ABS Indicator Checking

NOTE:

- The ABS indicator blinks or comes on and stays on when the ABS control unit has been disrupted by an extremely powerful radio wave (electromagnetic interference). This is just a temporary symptom. Erase the problem code and the ABS control unit is normal unless the symptom occurs again.

Turn the ignition switch to "ON" and check the ABS indicator.

**Is the indicator blinking?**

**NO** – GO TO STEP 2.

**YES** – GO TO STEP 3.

#### 2. ABS Indicator Function Inspection

Retrieve the problem code and erase it. Perform the pre-start self-diagnosis and check the ABS indicator.

**Is the indicator blinking?**

**NO** – Normal (temporary failure). Fine foreign matter in modulator or the ABS control unit has been disrupted by an extremely powerful radio wave. Check the connector and wire harness for loose connection.

**YES** – GO TO STEP 3.

#### 3. Check Problem Code

Retrieve the problem code and record the latest problem code.

**Is any problem code indicated?**

**CODE 11** – GO TO STEP 4.

**OTHER THAN CODE 11** – Diagnose at the latest problem code.

**4. Modulator Inspection by Replacing the Front and Rear Modulators**

Disconnect the (2), (3), (4) and (5) connectors from the front and rear modulators. Connect the (5) and (4) connectors to the front modulator, and the (2) and (3) connectors to the rear modulator conversely. Perform the pre-start self-diagnosis and retrieve the problem code, and record it.

**Is any problem code indicated?**

**CODE 10** – Faulty rear modulator assembly.

**CODE 11** – Faulty ABS control unit.

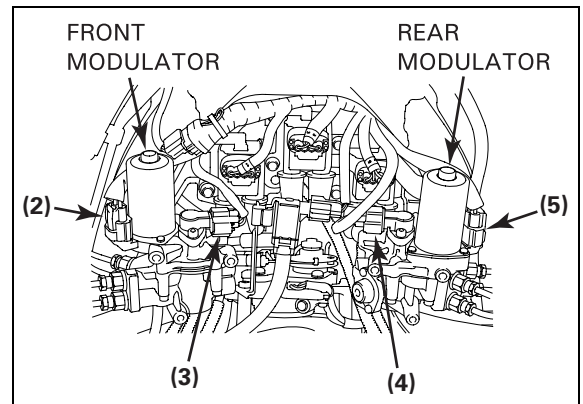

**Problem Code 12 and 13: ABS control unit (front and rear motor driver circuit)**

**1. ABS Indicator Checking**

NOTE:

- The ABS indicator blinks or comes on and stays on when the ABS control unit has been disrupted by an extremely powerful radio wave (electromagnetic interference). This is just a temporary symptom. Erase the problem code and the ABS control unit is normal unless the symptom occurs again.

Turn the ignition switch to "ON" and check the ABS indicator.

**Is the indicator blinking?**

**NO** – GO TO STEP 2.

**YES** – GO TO STEP 3.

**2. ABS Indicator Function Inspection**

Retrieve the problem code and erase it. Perform the pre-start self-diagnosis and check the ABS indicator.

**Is the indicator blinking?**

**NO** – Normal (temporary failure). Fine foreign matter in modulator or the ABS control unit has been disrupted by an extremely powerful radio wave. Check the connector and wire harness for loose connection.

**YES** – GO TO STEP 3.

**3. Check Problem Code**

Retrieve the problem code and record the latest problem code.

**Is the problem code 12, 13 or other?**

**CODE 12 or 13** – Faulty ABS control unit.

**OTHER THAN CODE 12 or 13** – Diagnose at the latest problem code.

## BRAKE SYSTEM (ABS)

### Problem Code 14: Power circuit

#### 1. Battery Charging System Inspection

##### NOTE:

- Ask the rider about the following when the motorcycle is brought in for inspection. This problem code will light up to indicate battery discharge.
  - Ask whether the motorcycle has been run with large capacity electric load accessories.
  - Ask whether the motorcycle has been left for long time with the ignition switch turned to “ON” (after the pre-start self-diagnosis).
- Check to see whether the indicated idle speed matches the specified idle speed.

Check the battery for charging condition.

##### *Is the charging system normal?*

**NO (low or no voltage)** – Check the battery charging system (section 16).

**YES** – GO TO STEP 2.

#### 2. ABS Indicator Function Inspection

Retrieve the problem code and erase it. Perform the pre-start self-diagnosis and check the ABS indicator.

##### *Is the indicator blinking?*

**NO (ON)** – GO TO STEP 3.

**NO (OFF)** – Normal (temporary failure). The ABS control unit has been disrupted by an extremely powerful radio wave. Check the connector and wire harness for loose connection.

**YES** – GO TO STEP 4.

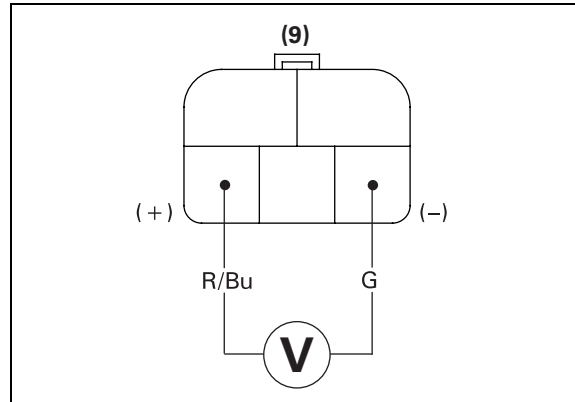

#### 3. Input Voltage Inspection

Disconnect the ABS control unit 5P connector (9) and (7). Measure the voltage between the Red/blue (+) and Green (-) terminals of the connector (9), and between the Red/green (+) and Green (-) terminals of the connector (7). There should be voltage at all times. Standard: 10 – 17V.

##### *Is the voltage within the standard value?*

**NO** – Check the wire between the battery and fuse box for open or short circuit. If the wire harness is OK, check the charging system (section 16).

**YES (normal 10 – 17 V at both connectors)** –

- Faulty ABS control unit.

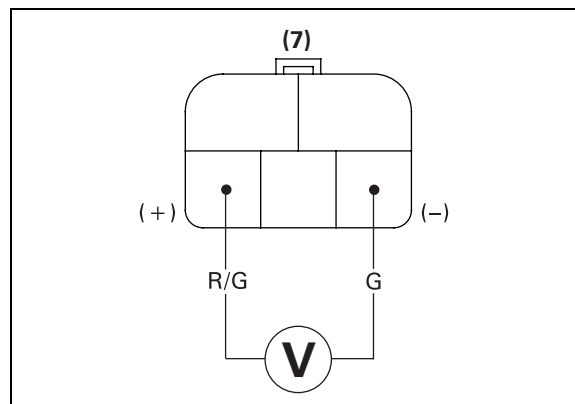

#### 4. Check Voltage After Replacing Battery

Retrieve the problem code and verify that the problem code is “14.” Erase the problem code. Replace the battery with a new fully charged battery. Perform the pre-start self-diagnosis and check the ABS indicator.

##### *Is the indicator blinking?*

**YES** – Faulty ABS control unit.

**NO** – Faulty removed battery.

**Problems Not Detected by ABS Control Unit (ABS indicator stays on)**

**1. Check Battery System**

Check the battery for charging condition.

**Is voltage within standard range?**

**NO (low or no voltage)** – Check the charging system (section 16).

**YES** – GO TO STEP 2.

**2. ABS Main Fuse No. 13 Inspection**

Check the ABS main fuse (No. 13; 5A).

**Is the fuse blown?**

**NO** – GO TO STEP 5.

**YES** – GO TO STEP 3.

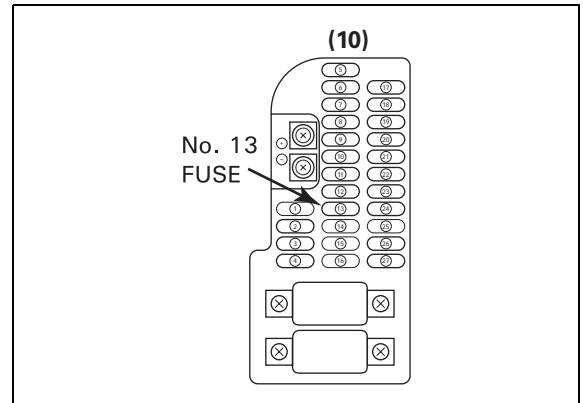

**3. Short Circuit Inspection Between Fuse Box and ABS Control Unit**

Disconnect the ABS control unit 5P connector (7). Check for continuity between the Red/blue terminal of the connector (7) and ground with the No. 13 fuse removed.

**Is there continuity?**

**NO** – Temporary failure (install a spare fuse and recheck).

**YES** – Short circuit in the wire between the fuse box and ABS control unit.

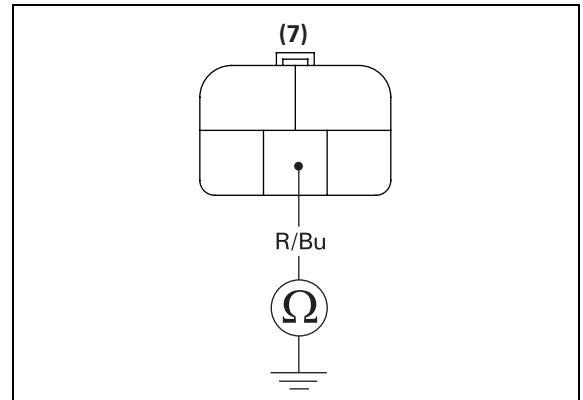

**4. Open Circuit Inspection Between Fuse Box and ABS Control Unit**

Install the fuse. Disconnect the ABS control unit (7). Measure the voltage between the Red/blue terminal (+) of the connector (7) and ground (-) with the ignition system turned to "ON."

**Is there voltage?**

**NO** – Open circuit in the wire between the fuse box and ABS control unit.

**YES** – GO TO STEP 5.

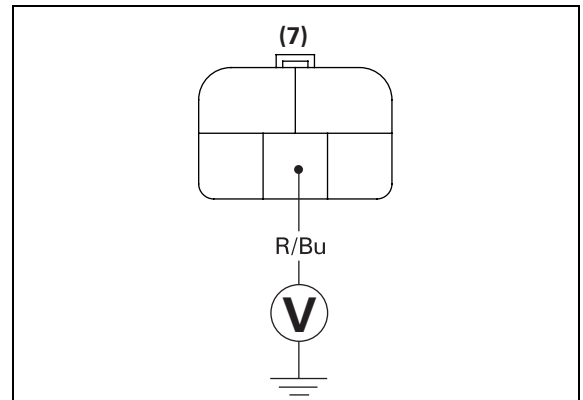

## BRAKE SYSTEM (ABS)

### 5. Open Circuit Inspection Between ABS Control Unit and Indicator

Connect the 5P connector (7). Disconnect the ABS control unit 5P connector (9). Measure the voltage between the Yellow/blue terminal (+) of the connector (9) and ground (-) with the ignition switch turned to "ON." Standard: 1 – 3V.

#### Is there voltage?

**NO** – Open circuit in the wire between the ABS control unit and combination meter (ABS indicator).

**YES (normal voltage)** – GO TO STEP 6.

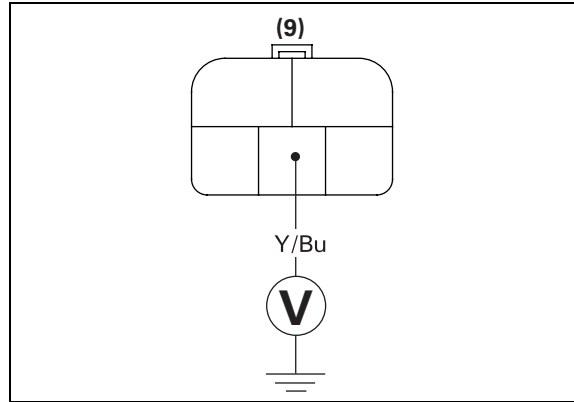

### 6. Open or Short Circuit Inspection Between ABS Control Unit and Wheel Speed Sensor

Connect the 5P connector (9). Disconnect the front and rear wheel speed sensor connectors (1) and (6). Measure the voltage between each connector (1) and (6), terminal (+) and ground (-) as shown with the ignition switch turned to "ON."

#### Is there voltage?

**NO** – Open or short circuit in the wire between the ABS control unit and front or rear wheel speed sensor.

**YES** – GO TO STEP 7.

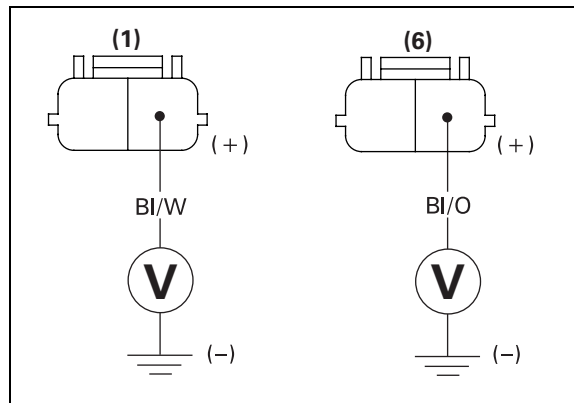

### 7. Open Circuit Inspection Between ABS Control Unit and Wheel Speed Sensor

Disconnect the ABS control unit 12P connector (8). Ground the Green/orange and Blue/yellow terminals of the connector (8) with jumper wires. Check for continuity between each connector (1) and (6) and ground as shown.

#### Is there continuity?

**NO** – Open circuit in the wire between the ABS control unit and front or rear wheel speed sensor.

**YES** – GO TO STEP 8.

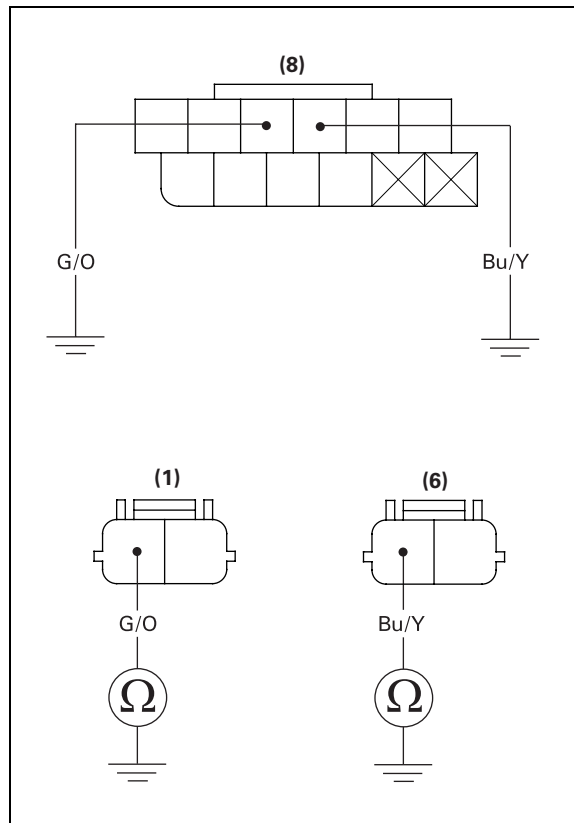



**8. ABS Indicator Checking**

Perform the pre-start self-diagnosis and check the ABS indicator.

***Does the indicator go off or stay on?***

**GOES OFF**—Normal (temporary failure). The ABS control unit has been disrupted by an extremely powerful radio wave. Check the connector and wire harness for loose connection.

**STAYS ON**—Faulty ABS control unit.

**WHEEL SPEED SENSOR**

**AIR GAP INSPECTION**

*Front sensor:* Raise the front wheel off the ground.

*Rear sensor:* Remove the rear fender A (page 2-13).

Measure the clearance (air gap) between the sensor and pulser ring at several points by turning the wheel slowly. It must be within specification.

**STANDARD: Front/rear: 0.4 – 1.2 mm (0.02 – 0.05 in)**

The sensor air gap cannot be adjusted. If it is not within specification, check each installation part for deformation, looseness and damage.

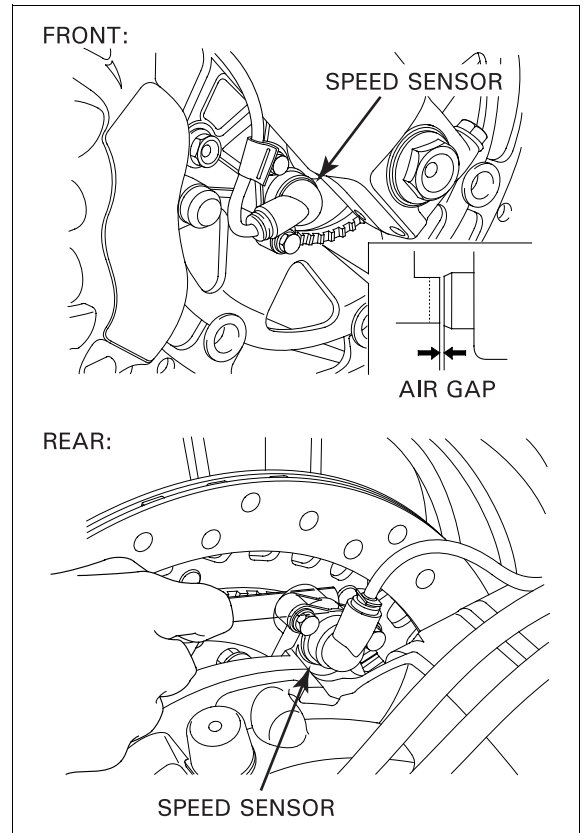

**REPLACEMENT**

**FRONT SENSOR**

Remove the following:

- right front fender cover (page 2-6)
- center inner fairing (page 2-10)

Disconnect the sensor 2P (orange) connector.

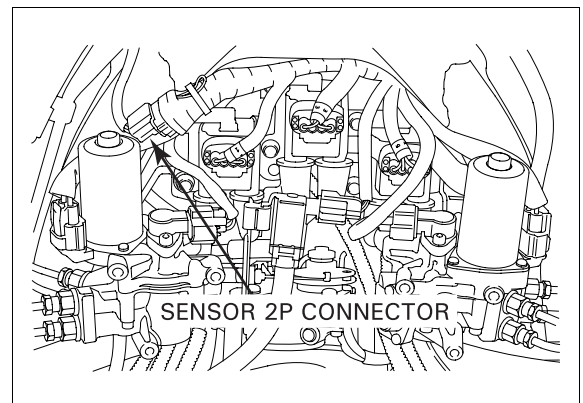

## BRAKE SYSTEM (ABS)

Remove the sensor wire from the clamps and clips.  
Remove the two bolts, clamp and speed sensor.

*Route the wire properly (page 1-23).*

Installation is in the reverse order of removal.

**TORQUE: 12 N·m (1.2 kgf·m, 9 lbf·ft)**

After installation, check the air gap (page 16-29).

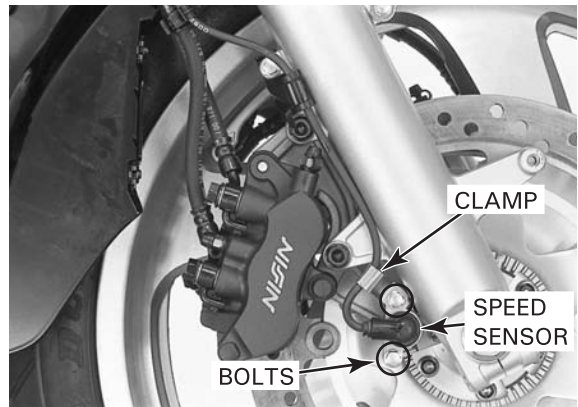

### REAR SENSOR

Remove the following:

- right saddle bag (page 2-15)
- fuel tank (page 5-56)

Disconnect the sensor 2P (gray) connector.

Remove the sensor wire from the clamps and clips.

Remove the two bolts and the speed sensor.

*Route the wire properly (page 1-23).*

Installation is in the reverse order of removal.

**TORQUE: 12 N·m (1.2 kgf·m, 9 lbf·ft)**

After installation, check the air gap (page 16-29).

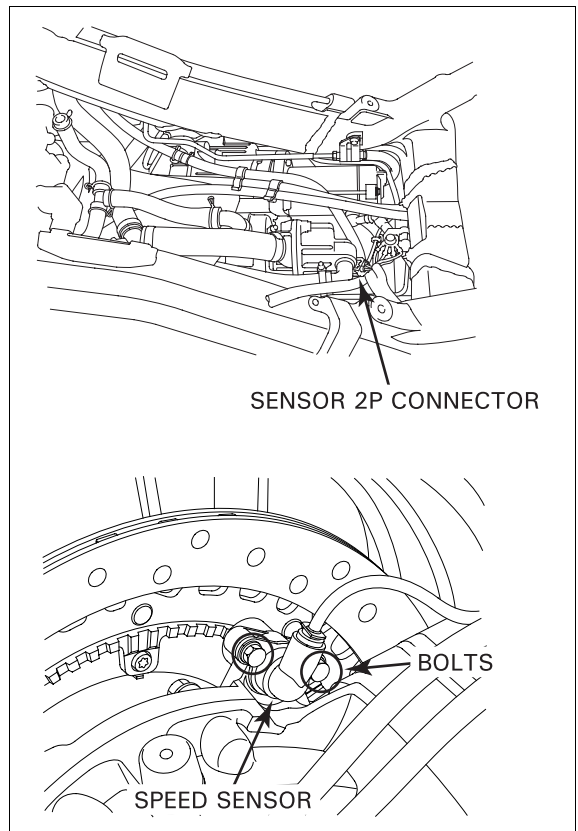

**ABS MODULATOR  
REMOVAL**

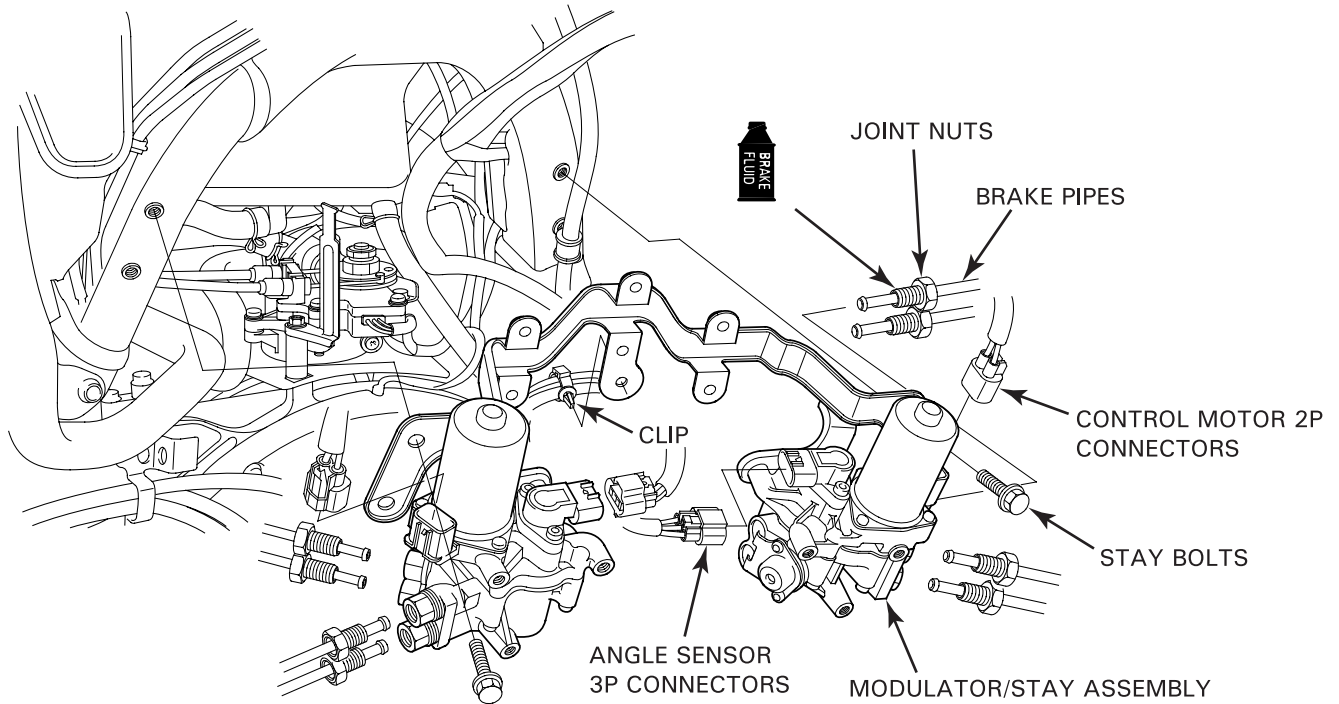

Drain the hydraulic brake system (page 15-6).

Remove the ignition coils (page 18-8).

Disconnect the control motor 2P (black) and crank angle sensor 3P (gray) connectors from each modulator.

*When loosening the joint nuts, cover the ends of the brake pipe to prevent contamination.*

Loosen the joint nuts to disconnect the brake pipe from each modulator.

Remove the following:

- spark plug wire clip from stay
- two stay bolts

*Be careful not to bend or damage the brake pipe and stay.*

- modulator/stay assembly from frame
- three mounting bolts and each modulator from the stay

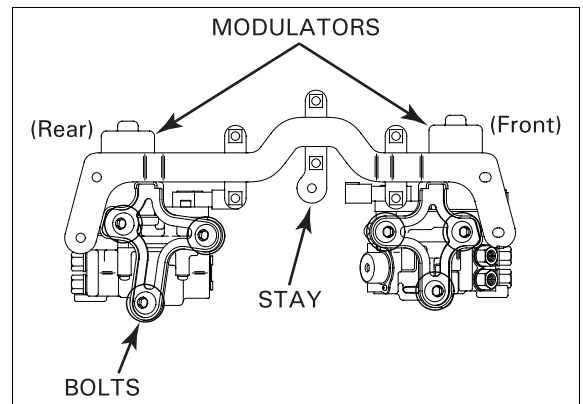

## BRAKE SYSTEM (ABS)

### INSTALLATION

*Route the wires properly (page 1-23).*

Install the modulators onto the stay with the mounting bolts.

**TORQUE: 12 N·m (1.2 kgf·m, 9 lbf·ft)**

Install the modulator/stay assembly, being careful not to interfere with the brake pipes and tighten the two stay bolts.

**TORQUE: 17 N·m (1.7 kgf·m, 12 lbf·ft)**

Install the clip of the spark plug wires into the stay.

Set the brake pipes into the modulator ports and make sure that the paint color on the brake pipes are aligned with the marks on the modulators.

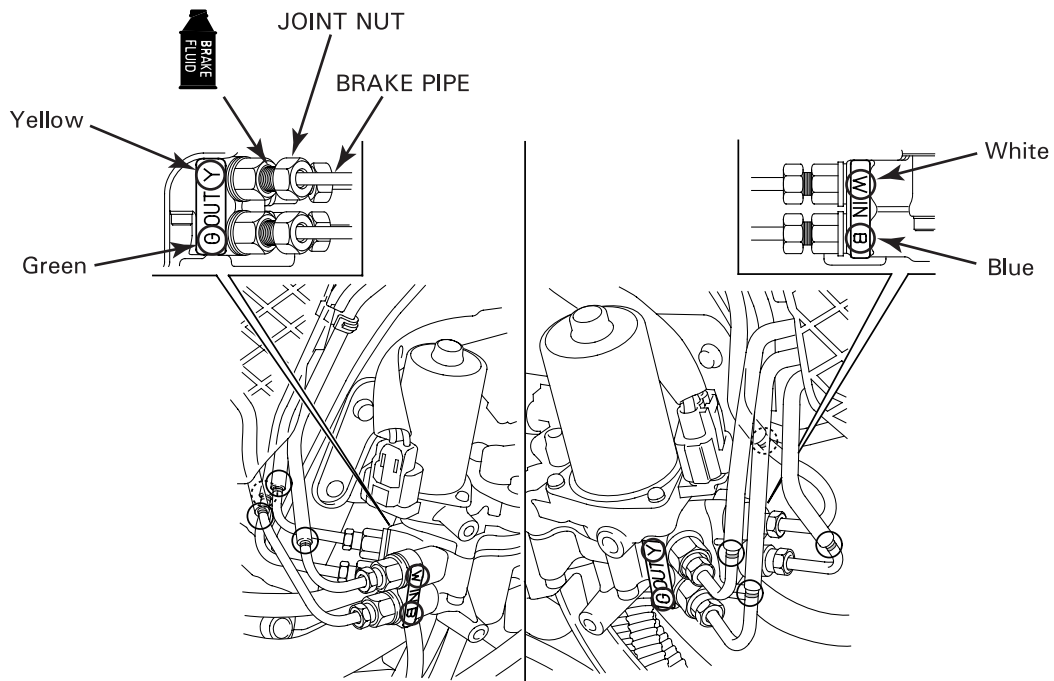

*Be careful not to cross-thread the joint nuts.*

Apply brake fluid to the joint nut threads on the brake pipes. Tighten the joint nuts to connect the brake pipes.

**TORQUE: 12 N·m (1.2 kgf·m, 9 lbf·ft)**

Connect the connectors to the modulators properly.

Install the ignition coils (page 18-8).

Fill and bleed the hydraulic brake system (page 15-6).

# 17. BATTERY/CHARGING SYSTEM

---

SYSTEM LOCATION.....	17-2	BATTERY.....	17-6
SYSTEM DIAGRAM.....	17-2	CHARGING SYSTEM INSPECTION.....	17-9
SERVICE INFORMATION .....	17-3	ALTERNATOR.....	17-10
TROUBLESHOOTING .....	17-5		

# BATTERY/CHARGING SYSTEM

## SYSTEM LOCATION

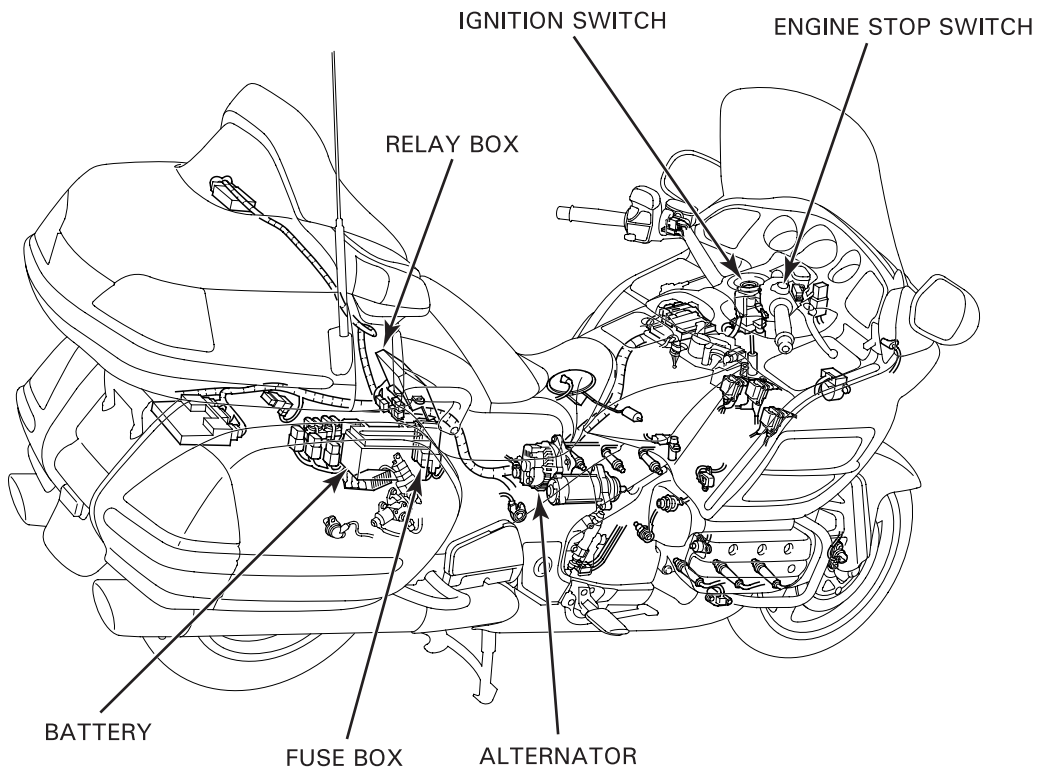

## SYSTEM DIAGRAM

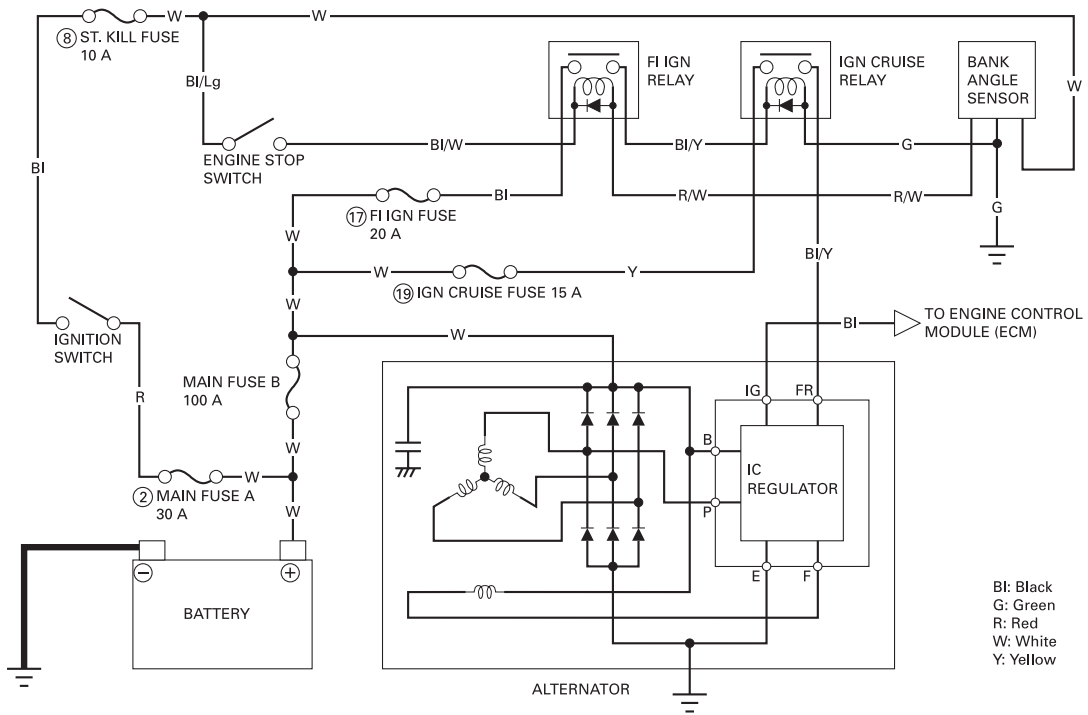



**SERVICE INFORMATION****GENERAL****⚠ WARNING**

- The battery gives off explosive gases; keep sparks, flames and cigarettes away. Provide adequate ventilation when charging.
- The battery contains sulfuric acid (electrolyte). Contact with skin or eyes may cause severe burns. Wear protective clothing and a face shield.
  - If electrolyte gets on your skin, flush with water.
  - If electrolyte gets in your eyes, flush with water for at least 15 minutes and call a physician immediately.
- Electrolyte is poisonous.
  - If swallowed, drink large quantities of water or milk and call your local Poison Control Center or a physician immediately.

- Always turn off the ignition switch before disconnecting any electrical component.
- Some electrical components may be damaged if terminals or connectors are connected or disconnected while the ignition switch is turned to "ON" and current is present.
- For extended storage, remove the battery, give it a full charge, and store it in a cool, dry place.
- For a battery remaining in a stored motorcycle, disconnect the negative battery cable from the battery.
- The battery sealing caps should not be removed. Attempting to remove the sealing caps from the cells may damage the battery.
- The maintenance free (MF) battery must be replaced when it reaches the end of its service life.
- The battery can be damaged if overcharged or undercharged, or if left to discharge for long periods. These same conditions contribute to shortening the "life span" of the battery. Even under normal use, the performance of the battery deteriorates after 2-3 years.
- Battery voltage may recover after battery charging, but under heavy load, the battery voltage will drop quickly and eventually die out. For this reason, the charging system is often suspected as the problem. Battery overcharge often results from problems in the battery itself, which may appear to be an overcharging symptom. If one of the battery cells is shorted and battery voltage does not increase, the regulator/rectifier supplies excess voltage to the battery. Under these conditions, the electrolyte level goes down quickly.
- Before troubleshooting the charging system, check for proper use and maintenance of the battery. Check if the battery is frequently under heavy load, such as having the headlight and taillight on for long periods of time without riding the motorcycle.
- The battery will self-discharge when the motorcycle is not in use. For this reason, charge the battery every 2 weeks to prevent sulfation from occurring.
- Filling a new battery with electrolyte will produce some voltage, but in order to achieve its maximum performance, always charge the battery. Also, the battery life is lengthened when it is initially charged.
- When checking the charging system, always follow the steps in the troubleshooting flow chart (page 17-5).
- The regulator/rectifier is located in the alternator.
- The alternator service may be done with the engine in the frame. For alternator driven gear removal/installation, see section 10.

**BATTERY CHARGING**

- This model comes with a maintenance free (MF) battery. Remember the following about MF batteries.
  - Use only the electrolyte that comes with the battery.
  - Use all of the electrolyte.
  - Seal the battery properly.
  - Never open the seals after installation.
- For battery charging, do not exceed the charging current and time specified on the battery. Using excessive current or extending the charging time may damage the battery.

**BATTERY TESTING**

Refer to the battery tester's Operation Manual for the recommended battery testing procedure. The recommended battery tester puts a "load" on the battery so the actual battery condition of the load can be measured.

**Recommended battery tester**

**BM-210-AH, BM-210 or BATTERY MATE**

# BATTERY/CHARGING SYSTEM

## SPECIFICATIONS





ITEM		STANDARD	SERVICE LIMIT	
Battery	Capacity	12 V - 18 Ah	-	
	Current leakage	5 mA max.	-	
	Voltage (20° C/68° F)	Fully charged	13.0 - 13.2 V	-
		Needs charging	Below 12.3 V	-
	Charging current	Normal	1.8 A x 5 - 10 h	-
Quick		9.0 A x 1.0 h	-	
Alternator	Capacity	1 kW @ 2,400 min <sup>-1</sup> (rpm)	-	
	Stator coil resistance (20° C/68° F)	0.07 - 0.09 Ω	-	
	Rotor coil resistance (20° C/68° F)	2.5 - 2.9 Ω	-	
	Rotor coil slip ring O.D.	22.7 mm (0.89 in)	21.2 mm (0.83 in)	

## TORQUE VALUES

Alternator mounting bolt  
Alternator terminal nut

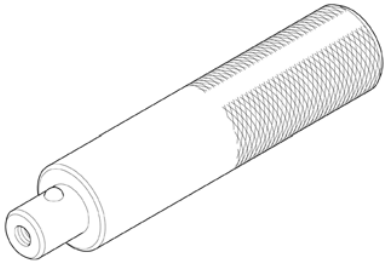
29 N·m (3.0 kgf·m, 22 lbf·ft)  
8 N·m (0.8 kgf·m, 5.8 lbf·ft)

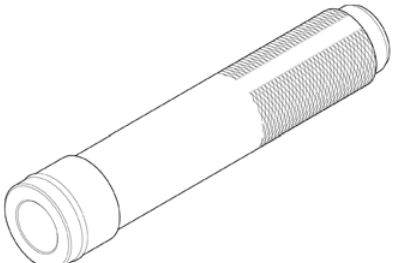
## TOOLS

<p>Driver 07749-0010000</p> 	<p>Pilot, 20 mm 07746-0040500</p> 	<p>Driver, 22 mm I.D. 07746-0020100</p> 
<p>Attachment, 20 mm I.D. 07746-0020400</p> 		

---

## TROUBLESHOOTING

### Battery is damaged or weak

#### 1. Battery Inspection

Remove the battery (page 17-6).

Check the battery condition using the recommended battery tester.

**RECOMMENDED BATTERY TESTER:**  
**BM-210-AH, BM-210 or BATTERY MATE**

*Is the battery voltage within 13.0–13.2 V?*

**NO** – Faulty battery.

**YES** – GO TO STEP 2.

#### 2. Battery Current Leakage Inspection

Install the battery (page 17-6).

Check the battery current leakage (CURRENT LEAKAGE TEST: page 17-9).

**SPECIFIED CURRENT LEAKAGE: 5 mA max.**

*Is the current equal to or less than the specified value?*

**NO** – Shorted wire harness.

**YES** – GO TO STEP 3.

#### 3. Battery Connection Inspection

Check the battery terminals, alternator cable terminal, and alternator 4P connector for loose or poor contacts.

*Are all battery connections tight?*

**NO** – Loose or poor contact terminal or connector.

**YES** – GO TO STEP 4.

#### 4. Charging Voltage Inspection

Measure and record the battery voltage using a digital multimeter (page 17-6).

Start the engine.

Measure the charging voltage (page 17-7).

Compare the measurements to the result of the following calculation.

**MEASURED BATTERY VOLTAGE < MEASURED  
CHARGING VOLTAGE < 15.5 V**

*Do the battery and charging voltages satisfy the calculation?*

**YES** – Faulty battery.

**NO** – GO TO STEP 5.

#### 5. Wire Harness Inspection

Perform the wire harness inspection (page 17-10).

*Is battery voltage present when tested as described?*

**NO** – Open circuit in wire harness.

**YES** – GO TO STEP 6.

#### 6. Alternator Inspection

Remove the alternator (page 17-10).

Disassemble the alternator and inspect the following:

- rotor coil (page 17-12)
- brush length (page 17-13)
- stator coil (page 17-13)

*Does the alternator test OK?*

**NO** – • Faulty rotor coil.  
• Worn brush.  
• Faulty stator coil.

**YES** – Faulty regulator/rectifier.

## BATTERY/CHARGING SYSTEM

### BATTERY

#### REMOVAL/INSTALLATION

Remove the left side cover (page 2-5).  
Remove the trim clip and battery plate.

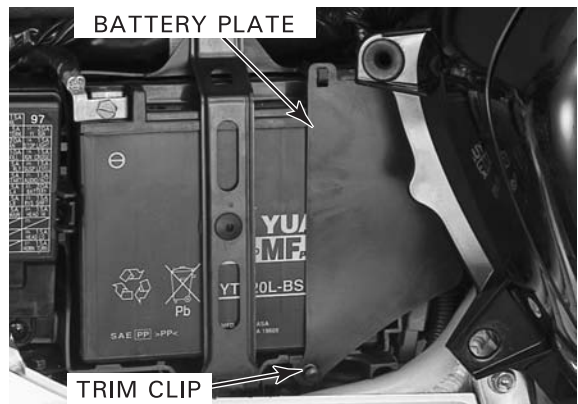

Remove the bolt and lower the battery holder.

With the ignition switch turned to "OFF," disconnect the negative (-) cable first, then disconnect the positive (+) cable.

Remove the battery from the battery case.

Install the battery in the reverse order of removal.

#### NOTE:

- Connect the positive (+) cable first, then connect the negative (-) cable.
- After connecting the battery cables, coat the terminals with grease.

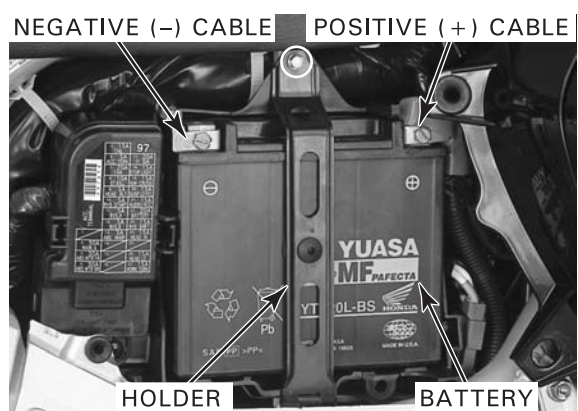

#### VOLTAGE INSPECTION

Remove the left side cover (page 2-5).

Measure the battery voltage using a commercially available digital multimeter.

#### VOLTAGE (20° C/68° F):

**Fully charged: 13.0 – 13.2 V**  
**Under charged: Below 12.3 V**



**BATTERY TESTING**

Remove the battery (page 17-6).

*For accurate test results, be sure the tester's cables and clamps are in good working condition and that a secure connection can be made at the battery.*

Securely connect the tester's positive (+) cable first, then connect the negative (-) cable.

**TOOL:**

**Battery tester**

**BM-210-AH or BM-210 (U.S.A. only)**

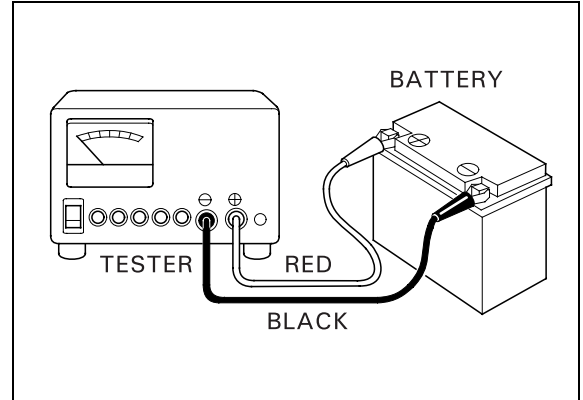

Set the temperature switch to "HIGH" or "LOW" depending on the ambient temperature.

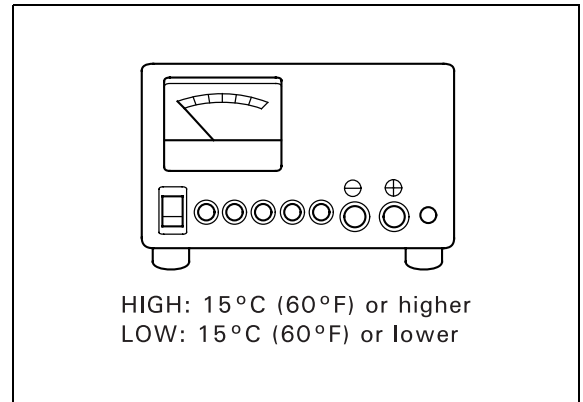

*For the first check, DO NOT charge the battery before testing; test it in an "as is" condition.*

Push in the appropriate test button for 3 seconds and read the condition of the battery on the meter.

**NOTICE**

- To avoid damaging the tester, only test batteries with an amperage rating of less than 30 Ah.
- Tester damage can result from overheating when:
  - The test button is pushed in for more than 3 seconds.
  - The tester is used without being allowed to cool for at least 1 minute when testing more than one battery.
  - More than ten consecutive tests are performed without allowing at least a 30-minute cool-down period.

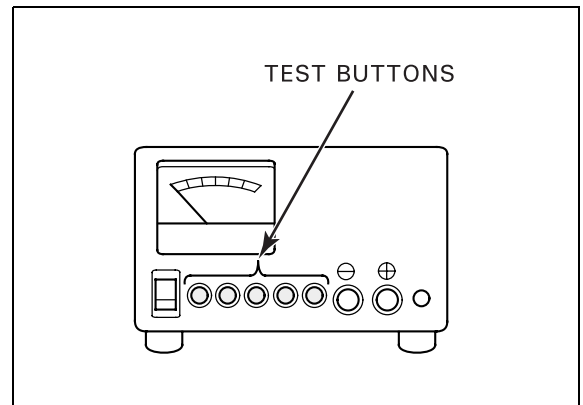

The result of a test on the meter scale is relative to the amp. hour rating of the battery. Any battery reading in the green zone is OK. Batteries should only be charged if they register in the YELLOW or RED zone.

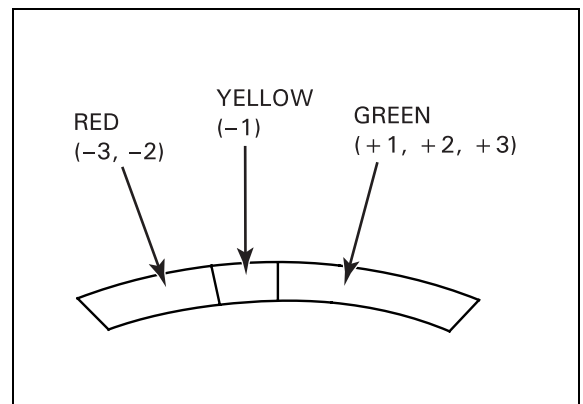

# BATTERY/CHARGING SYSTEM

## BATTERY CHARGING

Remove the battery (page 17-6).

### NOTE:

- Make sure the area around the charger is well ventilated, clear of flammable materials, and free from heat, humidity, water and dust.
- Clean the battery terminals and position the battery as far away from the charger as the leads will permit.
- Do not place batteries below the charger – gases from the battery may corrode and damage the charger.
- Do not place batteries on top of the charger. Be sure the air vents are not blocked.

1. Turn the "POWER" switch to "OFF."

*Turn the power ON/  
OFF at the charger,  
not at the battery  
terminals.*

2. Set the "BATTERY AMP. HR. SELECTOR SWITCH" for the size of the battery being charged.

### TOOL:

**Christie battery charger**

**MC1012/2  
(U.S.A. only)**

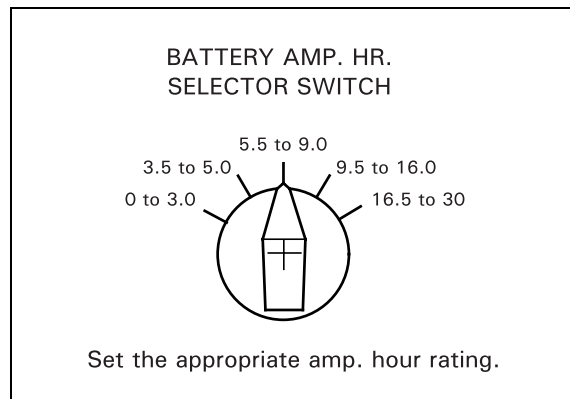

3. Set the "TIMER" to the position indicated by the Honda Battery Tester; RED-3, RED-2 or YELLOW-1. If you are charging a new battery, set the switch to the NEW BATT position.

4. Attach the clamps to the battery terminals: red to positive, black to negative.

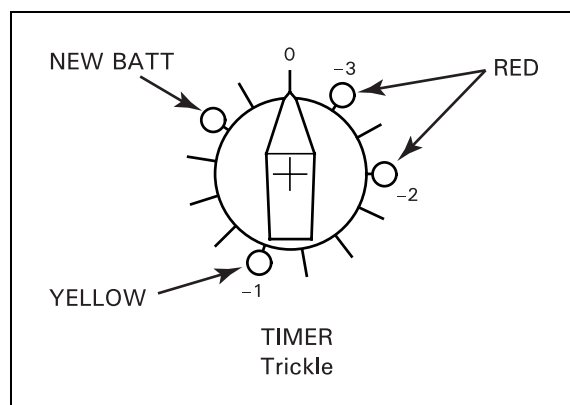

*Connecting the  
cables with the  
POWER switch  
turned to "ON" can  
produce a spark  
which could ignite  
or explode the  
battery.*

Connect the battery cables only when the "POWER" switch is turned to "OFF".

5. Turn the "POWER" switch to "ON".

*The charger will  
automatically  
switch to the  
"Trickle" mode after  
the set charging  
time has elapsed.*

6. When the timer reaches the "Trickle" position, the charging cycle is complete. Turn the "POWER" switch to "OFF" and disconnect the clamps.

7. Let the battery cool for at least 10 minutes or until gassing subsides after charging.

8. Retest the battery using the Honda battery tester and recharge if necessary using the above steps.



## CHARGING SYSTEM INSPECTION

### CURRENT LEAKAGE TEST

Remove the left side cover (page 2-5).

Turn the ignition switch to "OFF," and disconnect the negative (-) cable from the battery.

Connect the ammeter (+) probe to the negative (-) cable and the ammeter (-) probe to the battery (-) terminal.

With the ignition switch turned to "OFF," check for current leakage.

**NOTE:**

- When measuring current using a tester, set it to a high range, and then bring the range down to an appropriate level. Current flow higher than the range selected may blow the fuse in the tester.
- While measuring current, do not turn the ignition switch to "ON." A sudden surge of current may blow the fuse in the tester.

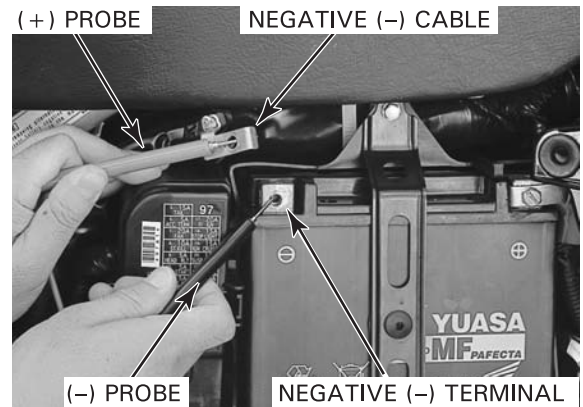

**SPECIFIED CURRENT LEAKAGE: 5 mA maximum**

If current leakage exceeds the specified value, a shorted circuit is the probable cause.

Locate the short by disconnecting connections one by one and measuring the current.

### CHARGING VOLTAGE INSPECTION

**NOTE:**

- Make sure the battery is in good condition before performing this test.

Remove the left side cover (page 2-5).

Start the engine and warm it up to the operating temperature; then stop the engine.

Connect the multimeter between the positive and negative terminals of the battery.

**NOTE:**

- To prevent a short, make absolutely certain which are the positive and negative terminals or cable.

With the headlight on high beam, restart the engine. Measure the voltage on the multimeter when the engine runs at 2,000 rpm.

**STANDARD:**

**Measured battery voltage (page 17-6) < Measured charging voltage (page 17-9) < 15.5 V**

*Do not disconnect the battery or any cable in the charging system without first switching off the ignition switch. Failure to follow this precaution can damage the tester or electrical components.*



## BATTERY/CHARGING SYSTEM

### WIRE HARNESS INSPECTION

Remove the left side cover (page 2-5).

Remove the left engine side cover (page 2-5).

*Be sure to disconnect the battery negative cable to prevent sparking when disconnecting or connecting the alternator cable.*

Disconnect the battery negative (-) cable from the battery.

Pull the rubber cap off the alternator terminal, remove the nut and disconnect the alternator cable. Disconnect the alternator 4P connector.

Connect the battery negative cable to the battery and check the following at the wire harness side:

#### BATTERY CHARGING LINE

Measure the voltage between the alternator cable terminal (+) and ground (-).

There should be battery voltage at all times.

#### BATTERY VOLTAGE LINE

Measure the voltage between the Black/yellow wire terminal (+) of the alternator 4P connector and ground (-).

There should be battery voltage with the ignition switch turned to "ON" and the engine stop switch turned to "⏻."

Install the removed parts in the reverse order of removal.

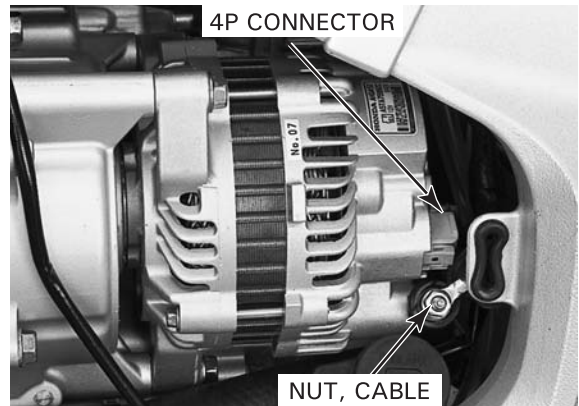

## ALTERNATOR

### REMOVAL

Remove the left engine side cover (page 2-5).

Remove the fuel tank (page 5-56).

Disconnect the alternator 4P connector.

Pull the rubber cap off the alternator terminal, remove the nut and disconnect the alternator cable.

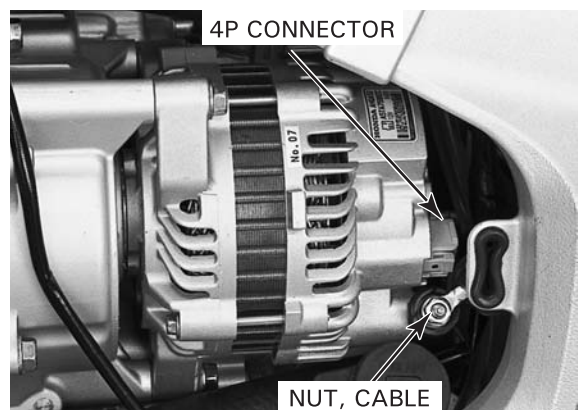

Remove the three mounting bolts and the alternator.

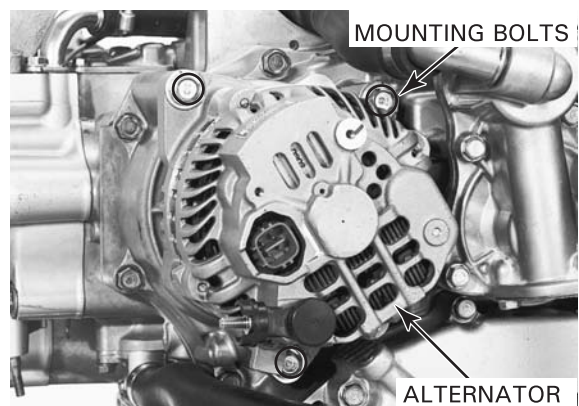

Remove the O-ring from the alternator.



### DISASSEMBLY

Mark the front and rear housings before disassembly to identify their original position. Remove the four bolts and separate the front housing/rotor from the rear housing/stator.

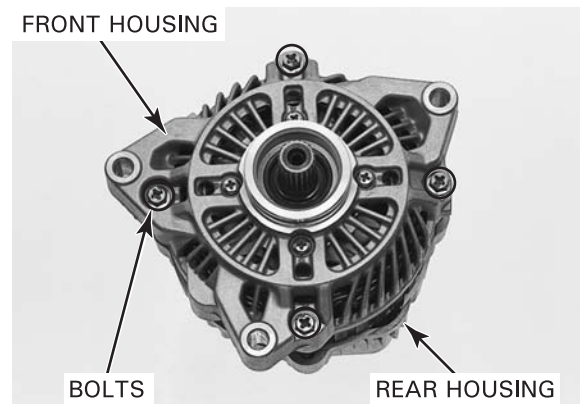

Remove the four screws and separate the rotor from the front housing. Remove the oil seal from the front housing.

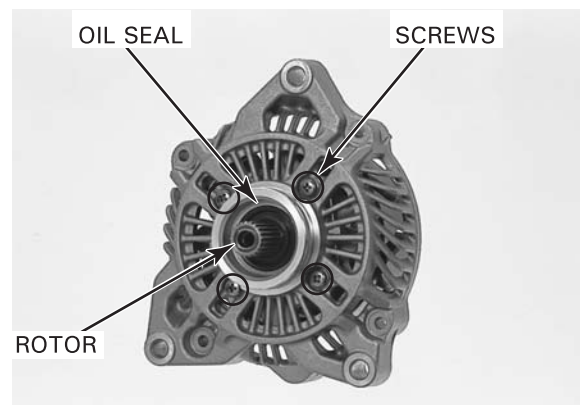

Remove the terminal cap, nut and terminal set from the rear housing.

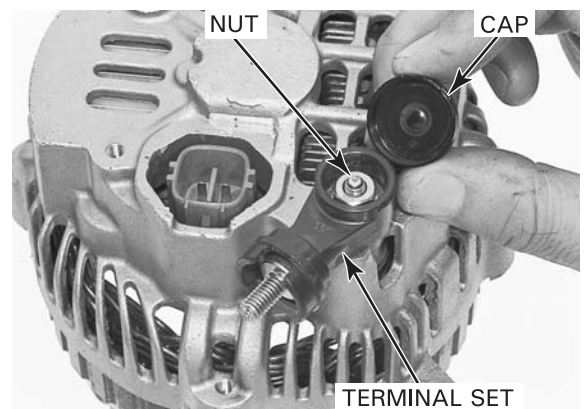

## BATTERY/CHARGING SYSTEM

Remove the spring washer from the rear housing.

Remove the three screws and separate the stator coil and regulator/rectifier assembly from the rear housing.

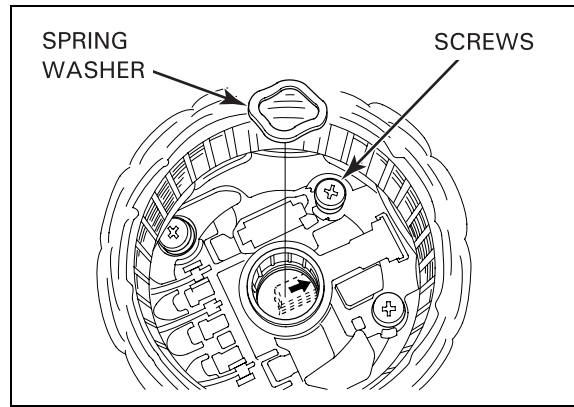

### INSPECTION

#### ROTOR COIL

Inspect the slip rings for discoloration.  
Measure the O.D. of the slip rings.

**SERVICE LIMIT: 21.2 mm (0.83 in)**

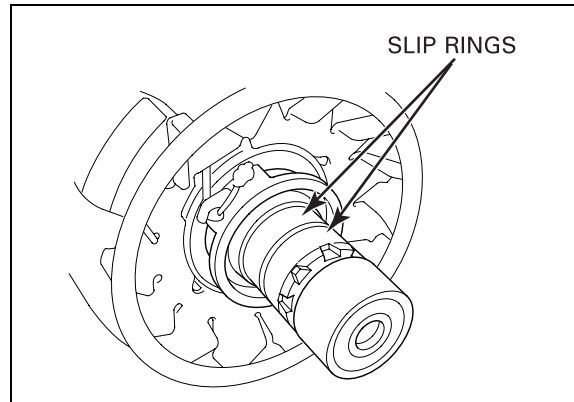

Measure the rotor coil resistance between the slip rings.

**STANDARD: 2.5 – 2.9  $\Omega$**



Check for continuity between the slip ring and rotor shaft.  
There should be no continuity.



## ROTOR BEARING

Turn the outer race of each bearing with your finger. The bearings should turn smoothly and quietly. Also check that the bearing inner race fits tightly on the rotor shaft.

Replace the bearings if the races do not turn smoothly, quietly, or if they fit loosely on the shaft (page 17-15).



## BRUSH LENGTH

*Always replace the brushes in pairs.*

Replace the brushes if they are worn to or near the wear lines.

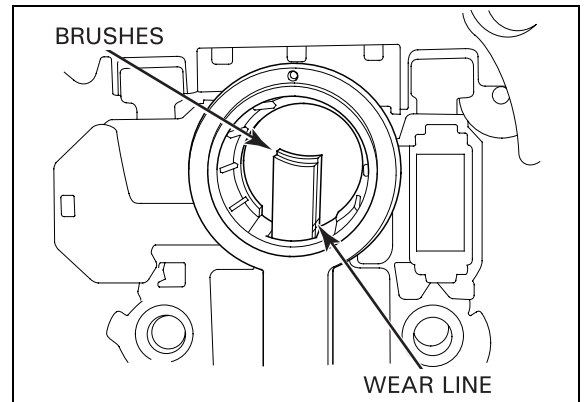

If replacement is necessary, remove the insulator and cap, melt the solder securing the brushes, and pull the brushes out of the brush holder.

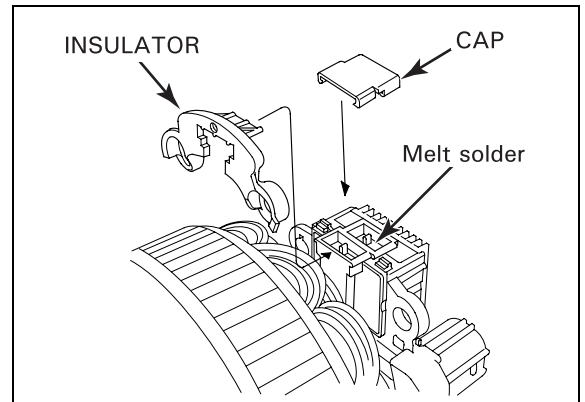

Install new brushes in the brush holder with their marked side facing to the front housing. Set the brushes at the installed length as shown.

**INSTALLED LENGTH: 1.5 mm (0.06 in)**

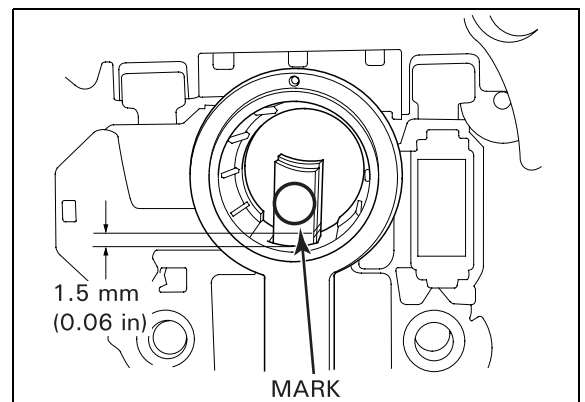



## BATTERY/CHARGING SYSTEM

Work quickly to avoid heat damage to the regulator/rectifier.

Heat the soldering iron (capacity: about 32 W) and use a low-temperature (180° – 200° C) solder to solder the brushes.

### NOTICE

- Make sure that solder does not enter the brush holder or the brush will not operate properly.
- Do not apply excess solder; align the solder end with the brush holder surface as shown.

Cut off the surplus brush wires.

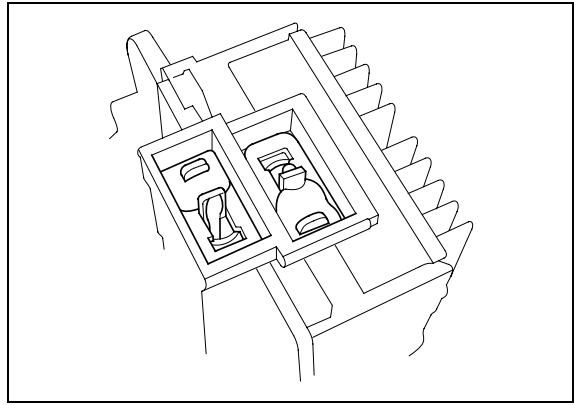

### STATOR COIL

Work quickly to avoid heat-damage to the regulator/rectifier. Hold the stator coil wire with pliers to dissipate heat.

Melt the solder and separate the stator coil from the regulator/rectifier.

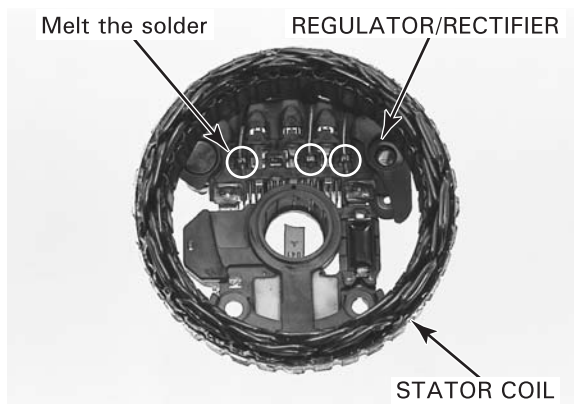

Measure the resistance between the stator coil wires.

**STANDARD: 0.07 – 0.09Ω at 20° C (68° F)**

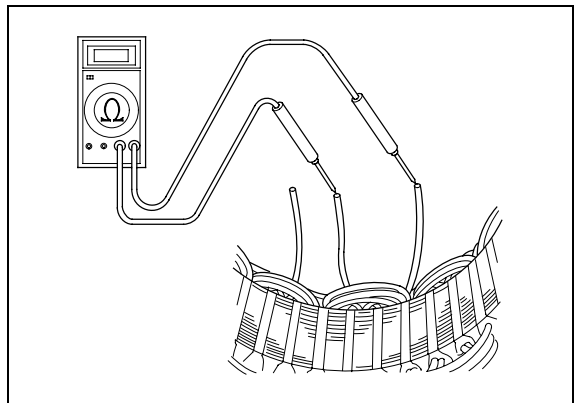

Put the tester probe on the silver color part of the core.

Check for continuity between the stator coil wire and stator core.

There should be no continuity.

For stator coil assembly, see page 17-14.

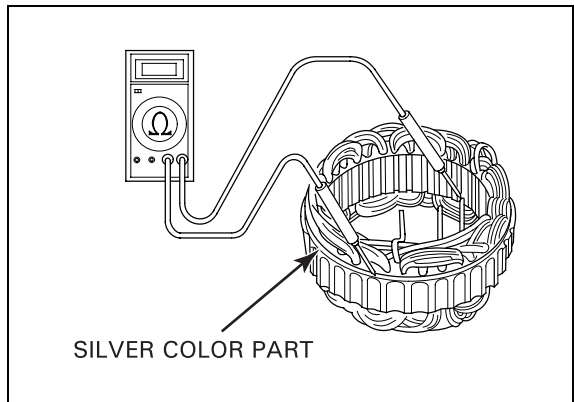



## RECTIFIER

See the wire diagram on page 17-2 for terminal locations.

Check for continuity in each direction between:

- B and P terminals
- E (ground) and P terminals

All diodes should have continuity in only one direction.

If any of the diodes fail, replace the regulator/rectifier assembly.

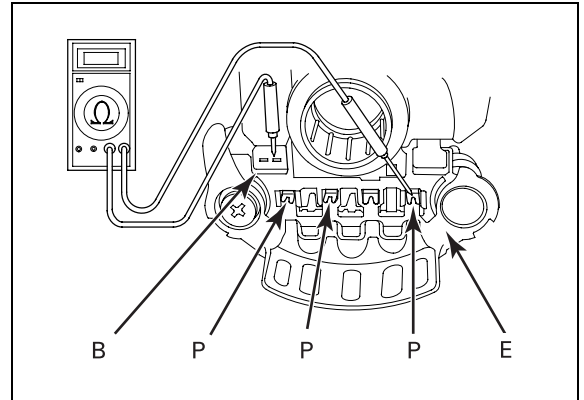

## ROTOR BEARING REPLACEMENT

Remove the front and rear rotor bearings using a bearing puller.

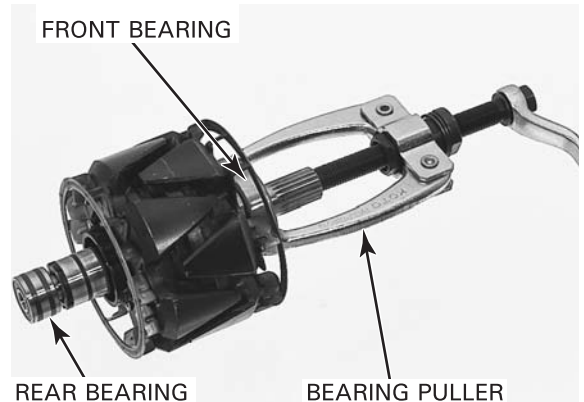

*Be sure to center the attachment with the bearing.*

Drive a new front bearing onto the rotor shaft using the special tools.

### TOOLS:

**Driver, 22 mm I.D.**

**07746-0020100**

**Attachment, 20 mm I.D.**

**07746-0020400**

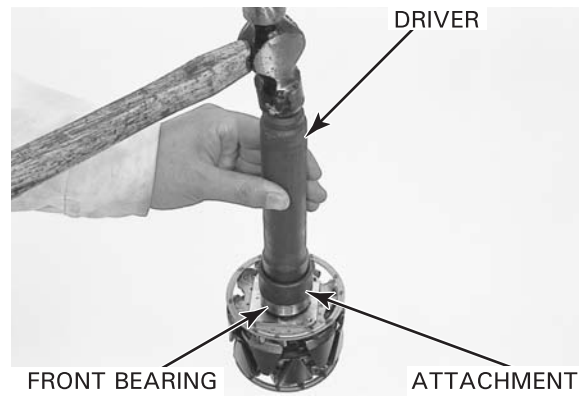

Drive a new rear bearing onto the rotor shaft using the special tools.

### TOOLS:

**Driver**

**07749-0010000**

**Pilot, 20 mm**

**07746-0040500**

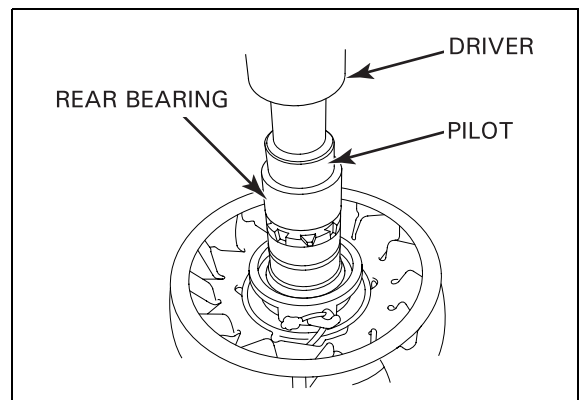

# BATTERY/CHARGING SYSTEM

## ASSEMBLY

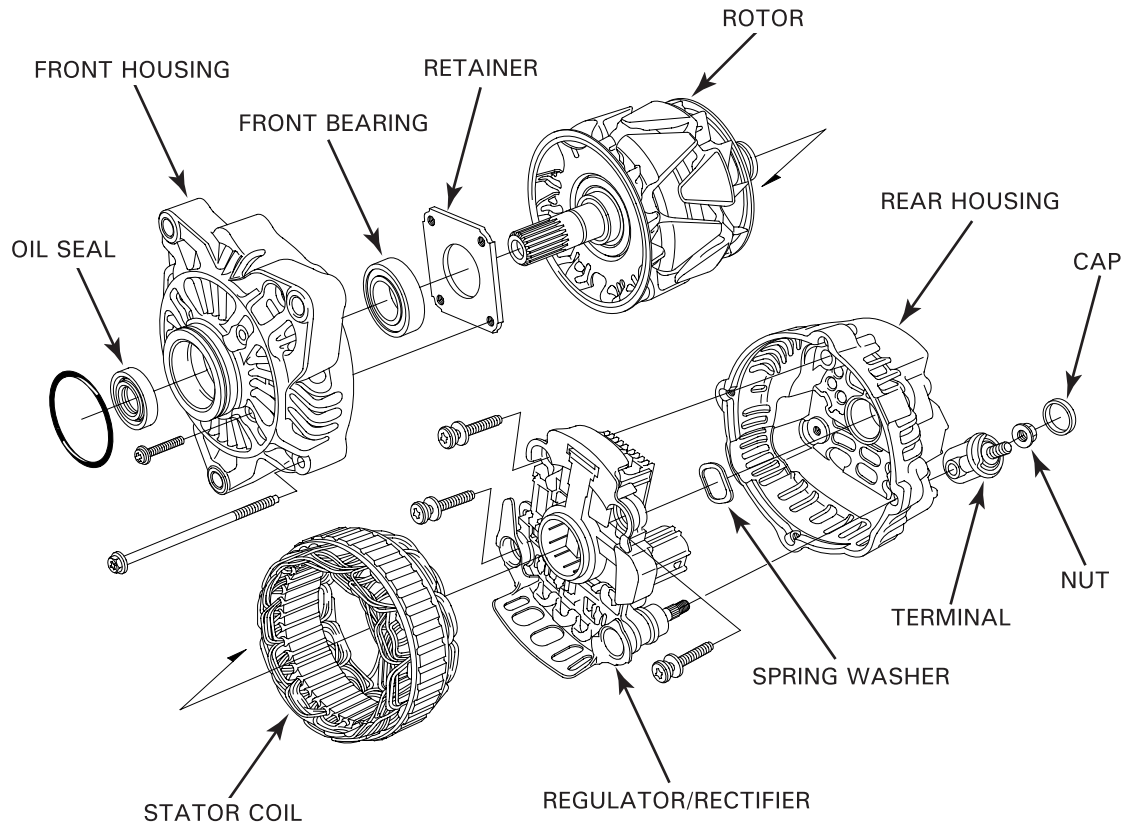

Heat a high-amperage soldering iron (capacity: about 110 W).

*Work quickly to avoid heat damage to the regulator/rectifier.*

Using a high-temperature (300°C), high lead content solder, join the stator and regulator/rectifier by soldering the stator coil wires on the diode terminals.

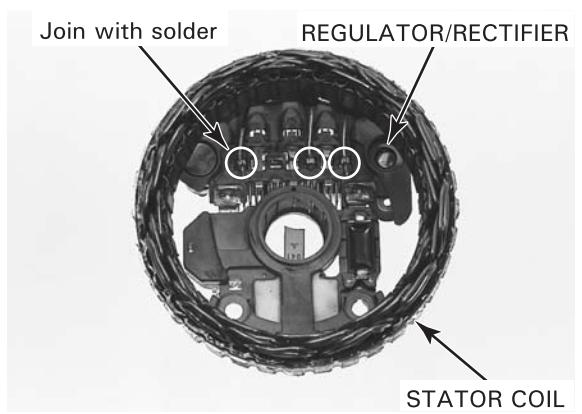

Push the brushes in the brush holder and insert an appropriate pin into the brush holder to hold the brushes.

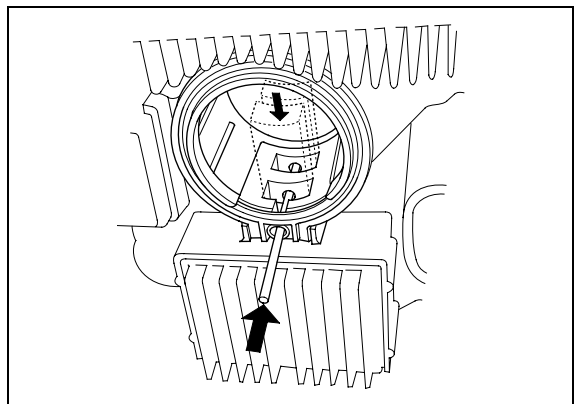

## BATTERY/CHARGING SYSTEM

Install the stator coil and regulator/rectifier assembly into the rear housing, while inserting the pin holding the brushes into the hole in the housing. Align the marks on the rear housing and stator.

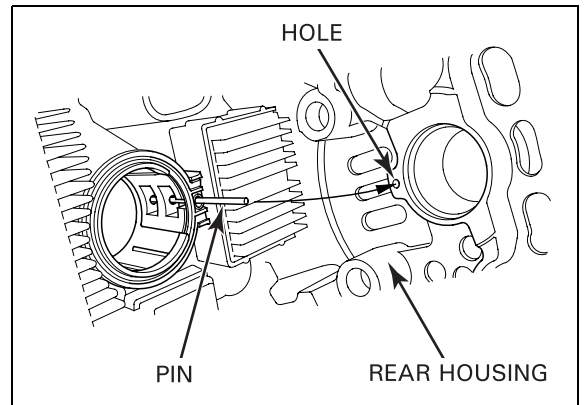

Install the three screws and tighten them securely.

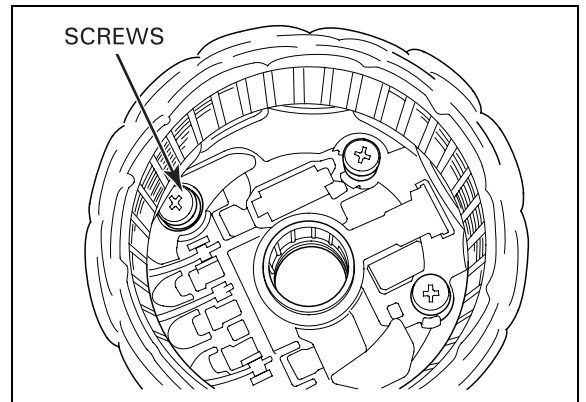

Install the terminal and nut, and tighten the nut.

**TORQUE: 8 N·m (0.8 kgf·m, 5.8 lbf·ft)**

Install the terminal cap.

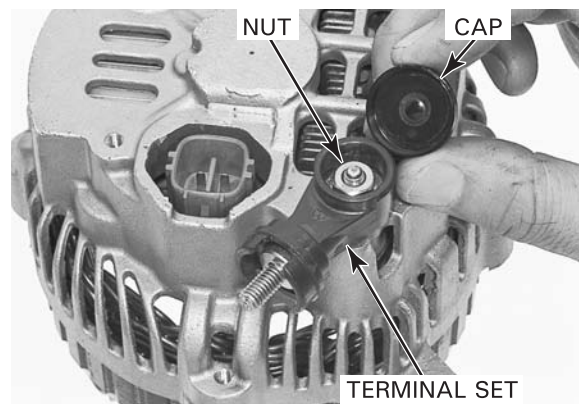

Apply grease to a new oil seal lip and install it into the front housing.



## BATTERY/CHARGING SYSTEM

Install the rotor into the front housing.  
Install the four screws and tighten them securely.

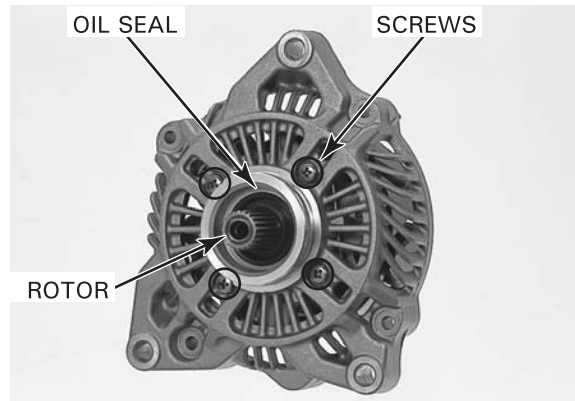

Install the spring washer into the rear housing.

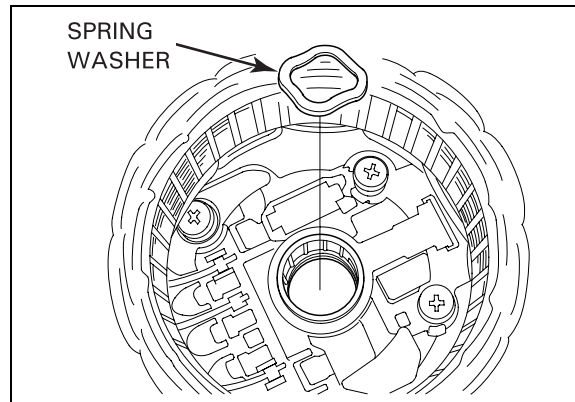

Install the front housing/rotor into the rear housing/  
stator, while aligning the marks on the front housing  
and stator.

Remove the pin holding the brushes from the rear  
housing.

Install the four bolts and tighten them securely.

Make sure the bolt holes in the rear housing align  
with the gaps between the stator core ridges.

### NOTE:

- Make sure the bolt holes in the rear housing align with the gaps between the stator core ridges.

FRONT HOUSING

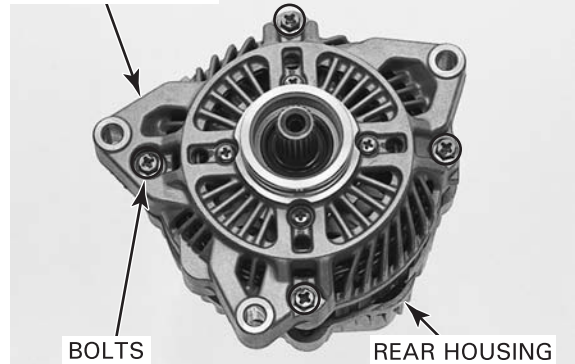

## INSTALLATION

Coat a new O-ring with oil and install it into the  
alternator groove.



## BATTERY/CHARGING SYSTEM

Install the alternator into the rear case and tighten the three mounting bolts.

**TORQUE: 29 N·m (3.0 kgf·m, 22 lbf·ft)**

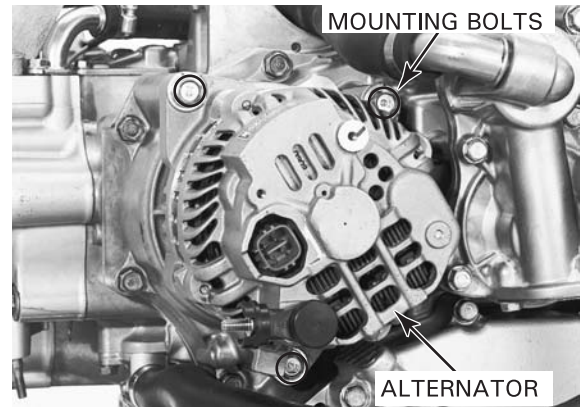

Connect the alternator cable and tighten the terminal nut securely.  
Install the rubber cap properly.  
Connect the alternator 4P connector.

Install the fuel tank (page 5-56).

Install the left engine side cover (page 2-5).

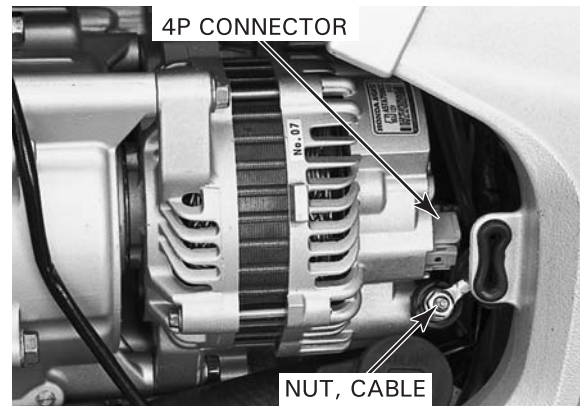

---

**MEMO**

---



# 18. IGNITION SYSTEM

---

SYSTEM LOCATION.....	18-2	IGNITION COIL .....	18-7
SYSTEM DIAGRAM.....	18-2	IGNITION PULSE GENERATOR.....	18-9
SERVICE INFORMATION .....	18-3	PGM-FI IGNITION RELAY .....	18-11
TROUBLESHOOTING .....	18-4	BANK ANGLE SENSOR .....	18-13
IGNITION SYSTEM INSPECTION.....	18-5	IGNITION TIMING .....	18-14

# IGNITION SYSTEM

## SYSTEM LOCATION

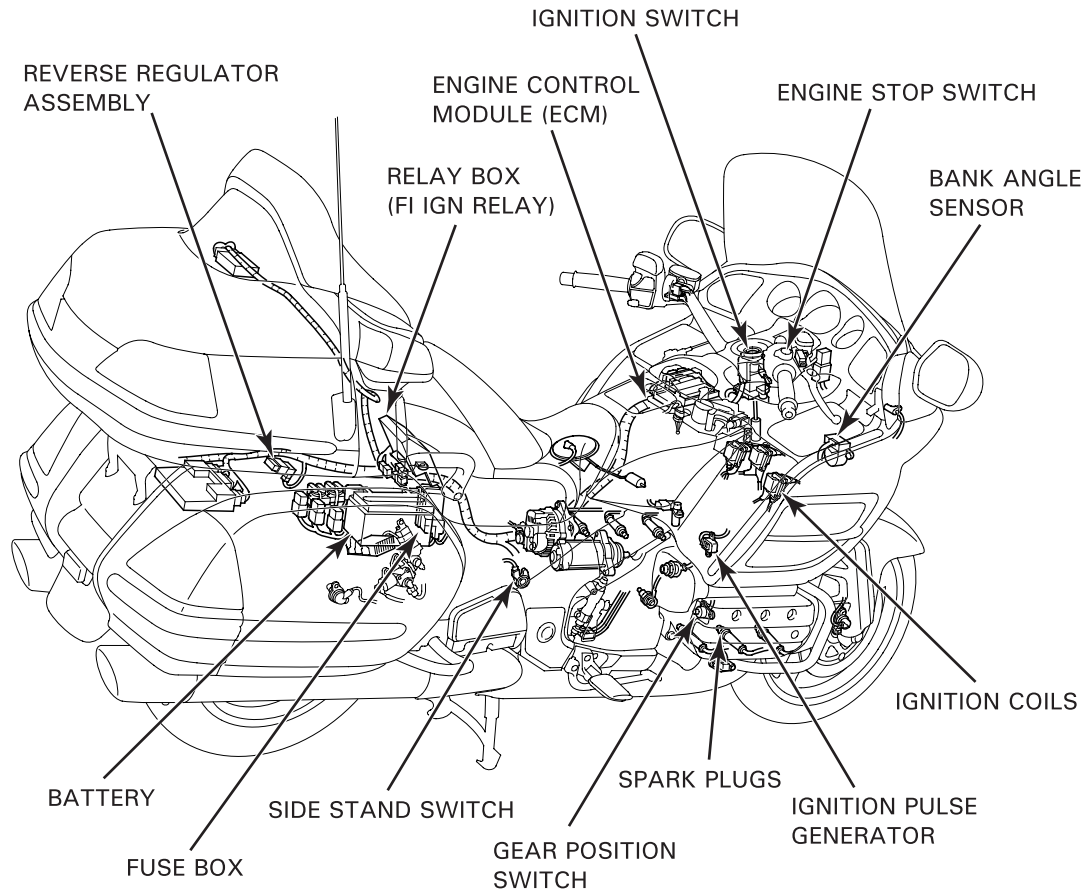

## SYSTEM DIAGRAM

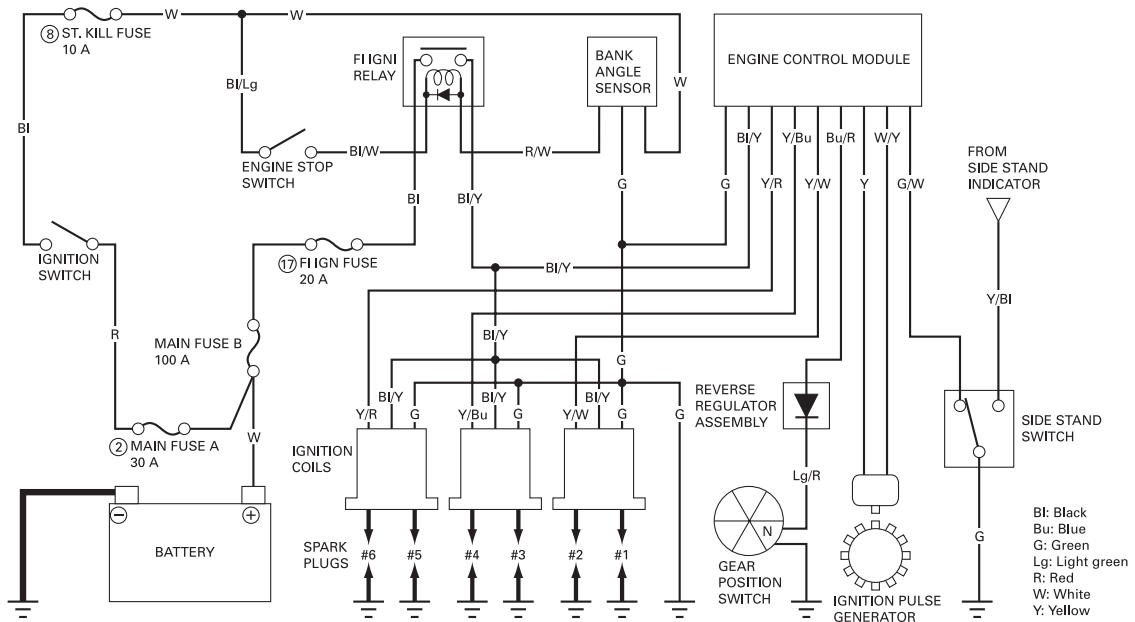

## SERVICE INFORMATION

### GENERAL

- Some electrical components may be damaged if terminals or connectors are connected or disconnected while the ignition switch is "ON" and current is present.
- When servicing the ignition system, always follow the steps in the troubleshooting table on page 18-4.
- This motorcycle's Ignition Control Module (ICM) is built into the Engine Control Module (ECM).
- The transistorized ignition system uses an electrically controlled ignition timing system. No adjustments can be made to the ignition timing.
- The ECM varies ignition timing according to the engine speed.
- The ECM may be damaged if dropped. Also, if the connector is disconnected when current is flowing, the excessive voltage may damage the ECM. Always turn the ignition switch to "OFF" before servicing.
- A faulty ignition system is often related to poor connections. Check those connections before proceeding.
- Make sure the battery is adequately charged. Using the starter motor with a weak battery results in a slower engine cranking speed as well as no spark at the spark plugs.
- This motorcycle's ignition coil is equipped with an ignitor. The ignition coil signal voltage from the ECM is converted to the high voltage in the ignition coil.
- For spark plug inspection, see section 3.
- See section 19 for the following components:
  - Ignition switch
  - Engine stop switch
  - Gear position switch
  - Side stand switch

### SPECIFICATIONS

ITEM		SPECIFICATIONS
Spark plug	Standard	BKR6E-11 (NGK), K20PR-U11 (DENSO)
	For cold climate (below 5° C/41° F)	BKR5E-11 (NGK), K16PR-U11 (DENSO)
	For extended high speed riding	BKR7E-11 (NGK), K22PR-U11 (DENSO)
Spark plug gap		1.0 – 1.1 mm (0.039 – 0.043 in)
Ignition coil signal peak voltage		2.5 – 5.0 V
Ignition pulse generator peak voltage		0.7 V minimum
Ignition timing ("F" mark)		0° BTDC at idle

### TORQUE VALUES

Ignition pulse generator bolt 12 N·m (1.2 kgf·m, 9 lbf·ft)

### TOOL

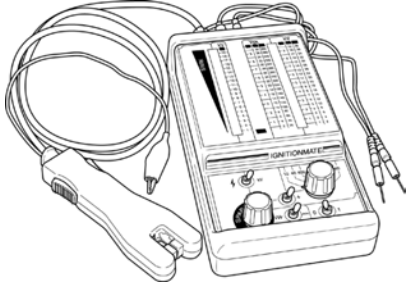
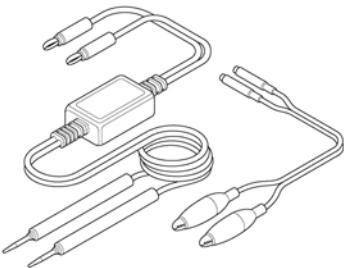
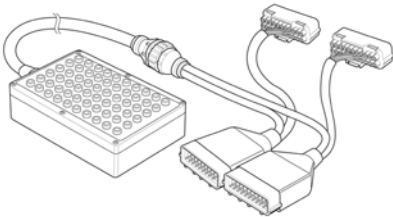
<p>IgnitionMate peak voltage tester MTP07-0286 (U.S.A. only)</p> 	<p>Peak voltage adaptor 07HGJ-0020100</p>  <p>(not available in U.S.A.) with commercially available digital multimeter (impedance 10 M<math>\Omega</math>/DCV minimum)</p>	<p>Test harness set 07WMZ-MBGA000</p> 
--	--	---

## IGNITION SYSTEM

### TROUBLESHOOTING

- Inspect the following before diagnosing the system.
  - Faulty spark plug.
  - Loose spark plug cap or spark plug wire connections.
  - Water in the spark plug cap (Leaking the ignition coil secondary voltage).
- If there is no spark at any cylinder, temporarily exchange the ignition coil with a known-good one and perform the spark test. If there is spark, the exchanged ignition coil is faulty.

#### No spark at spark plugs

UNUSUAL CONDITION		PROBABLE CAUSE (check in numerical order)
Ignition coil signal voltage	No peak voltage	<ol style="list-style-type: none"><li>1. The multimeter impedance is too low; below 10 M<math>\Omega</math>DCV.</li><li>2. Cranking speed is too low (battery is undercharged).</li><li>3. The sampling timing of the tester and measured pulse were not synchronized. (System is normal if the measured voltage is over the standard voltage at least once.)</li><li>4. Faulty side stand switch or gear position (neutral) switch.</li><li>5. An open circuit or loose connection in No. 4 related circuit wires.<ul style="list-style-type: none"><li>– Side stand switch line: Green/white wire</li><li>– Neutral switch line: Blue/red and Light green/red wires</li></ul></li><li>6. Open or short circuit in the ignition coil signal wire (No. 1 &amp; 2: Yellow/white, No. 3 &amp; 4: Yellow/blue, No. 5 &amp; 6: Yellow/red).</li><li>7. Faulty peak voltage adaptor.</li><li>8. Faulty engine control module (ECM) (when No. 1 through 7 are normal).</li></ol>
	Peak voltage is normal, but no spark.	<ol style="list-style-type: none"><li>1. Open circuit in ignition coil power input or ground line (page 18-5).</li><li>2. Ignition coil is leaking secondary current amperage.</li><li>3. Faulty spark plug wire</li></ol>
Ignition pulse generator	Low peak voltage	<ol style="list-style-type: none"><li>1. The multimeter impedance is too low; below 10 M<math>\Omega</math>DCV.</li><li>2. Cranking speed is too slow (battery is undercharged).</li><li>3. The sampling timing of the tester and measured pulse were not synchronized. (System is normal if the measured voltage is over the standard voltage at least once.)</li><li>4. Faulty ignition pulse generator (when causes No. 1 through 3 are normal).</li></ol>
	No peak voltage	<ol style="list-style-type: none"><li>1. Faulty peak voltage adaptor.</li><li>2. Faulty ignition pulse generator.</li></ol>

## IGNITION SYSTEM INSPECTION

**NOTE:**

- If there is no spark present at the plugs, check all connections for loose or poor contact before measuring the peak voltage.
- Use a commercially available digital multimeter (impedance 10 M $\Omega$ /DCV minimum).
- The display value differs depending upon the internal impedance of the multimeter.

Connect the peak voltage adaptor to the digital multimeter.

**TOOLS:**

- Peak voltage tester (U.S.A. only) or 07HGJ-0020100**
- Peak voltage adaptor (not available in U.S.A.) with commercially available digital multimeter (impedance 10 M $\Omega$ /DCV minimum)**

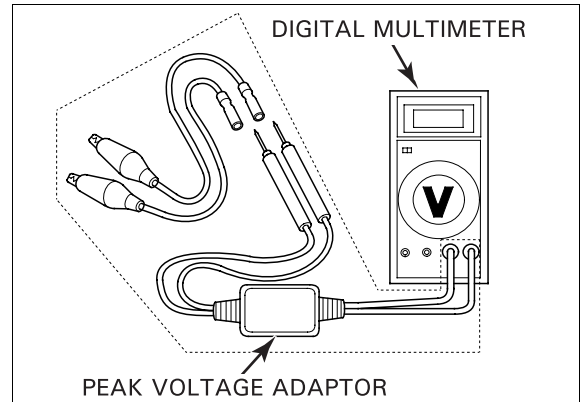

Remove the seat (page 2-5).

Disconnect the fuel pump 5P connector.

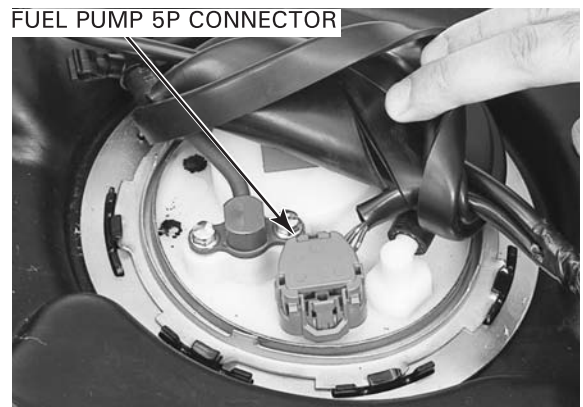

### IGNITION COIL SIGNAL PEAK VOLTAGE

**NOTE:**

- Check all system connections before performing this inspection. Loose connectors can cause incorrect readings.
- Check that the cylinder compression is normal for each cylinder and the spark plug is installed correctly in the cylinder head.

Remove the center inner fairing (page 2-10).

Disconnect the ignition coil 4P connector.

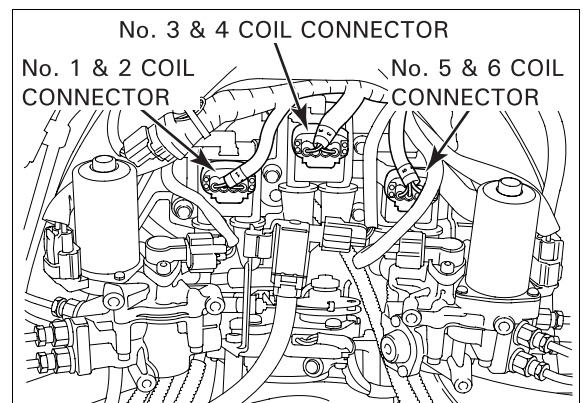

## IGNITION SYSTEM

Connect the peak voltage tester or adaptor probes to the wire harness side connector terminal and ground.

### CONNECTION:

**No. 1 & 2 ignition coil:**

**Yellow/white (+) – Ground (-)**

**No. 3 & 4 ignition coil:**

**Yellow/blue (+) – Ground (-)**

**No. 5 & 6 ignition coil:**

**Yellow/red (+) – Ground (-)**

Shift the transmission into neutral.

*Make sure the engine stop switch is turned to "O."*

Turn the ignition switch to "ON."

Crank the engine with the starter motor and measure the ignition coil signal peak voltage.

**PEAK VOLTAGE: 2.5 – 5.0 V**

### NOTE:

- Although measured values are different for each ignition coil, they are normal as long as voltage is higher than the specified value.

If the peak voltage is lower than the standard value, follow the checks described in the troubleshooting chart on page 18-4.

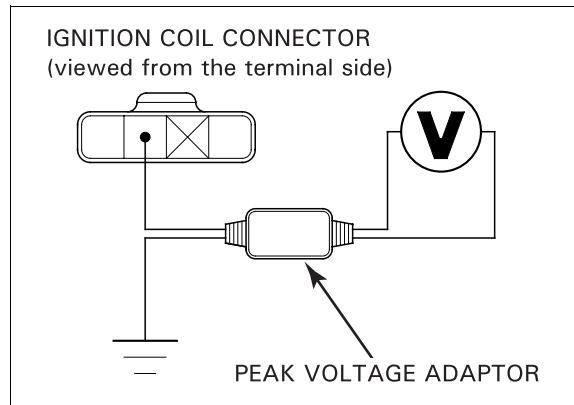

## IGNITION PULSE GENERATOR PEAK VOLTAGE

### NOTE:

- Check that the cylinder compression is normal for each cylinder and the spark plug is installed correctly in the cylinder head.

Connect the test harnesses set to the ECM connectors (page 5-11).

### TOOLS:

**Test harness set**

**07WMZ-MBGA000**

Connect the peak voltage tester or adaptor probes to the test pin box terminals.

**CONNECTION: No. 41 (+) – No. 21 (-)**

Shift the transmission into neutral.

*Make sure the engine stop switch is turned to "O."*

Turn the ignition switch to "ON."

Crank the engine with the starter motor and measure "the ignition pulse generator peak voltage"

**PEAK VOLTAGE: 0.7 V minimum**

If the voltage measured at the ECM connector is abnormal, measure the peak voltage at the ignition pulse generator connector.

Turn the ignition switch to "OFF."

Remove the air cleaner housing (page 5-57).

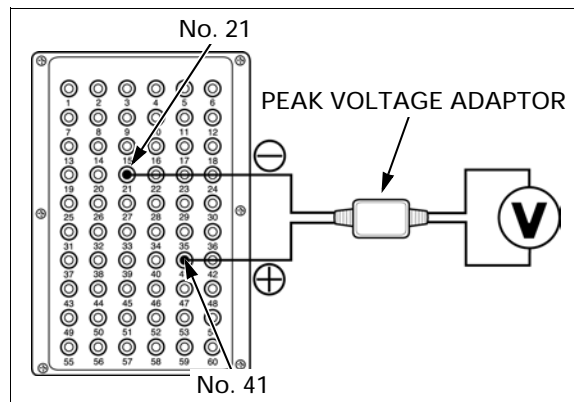



Disconnect the ignition pulse generator 2P red connector and connect the peak voltage tester or adaptor probes to the ignition pulse generator side connector terminals.

**CONNECTION: Yellow (+) – White/yellow (-)**

In the same manner as at the ICM connector, measure the peak voltage and compare it to the voltage measured at the ECM connector.

- If the peak voltage measured at the ECM connector is abnormal and the measurement at the ignition pulse generator connector is normal, the Yellow or White/yellow wire has an open or short circuit, or loose connections.
- If both peak voltages are abnormal, follow the checks described in the troubleshooting chart on page 18-4.

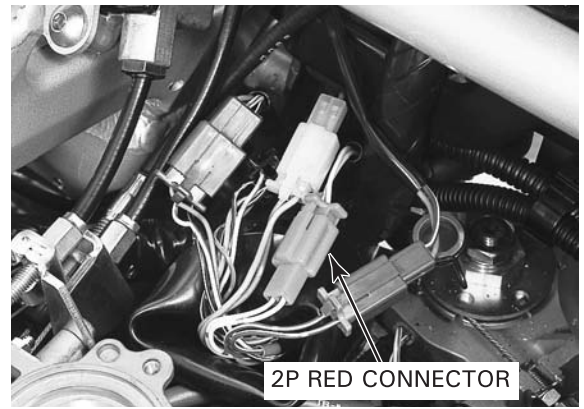

## IGNITION COIL

### POWER/GROUND LINE INSPECTION

**NOTE:**

- If the ignition coil signal voltage is normal but there is no spark at the plug, perform this inspection.

Remove the center inner fairing (page 2-10).

Turn the ignition switch "OFF."

Disconnect the ignition coil 4P connector.

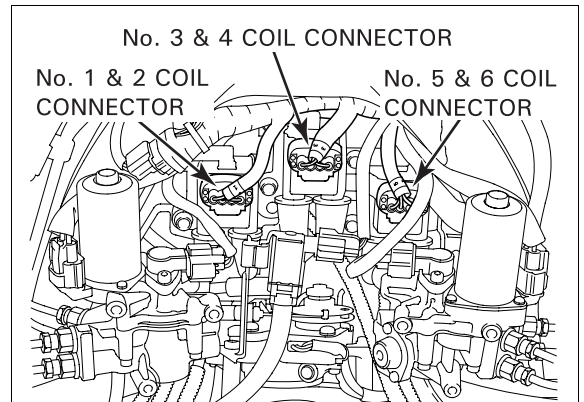

### POWER INPUT LINE

*Make sure the engine stop switch is turned to "Q."*

1. Turn the ignition switch "ON" and check the PGM-FI malfunction indicator lamp (MIL).
  - If the MIL stays on, check the PGM-FI ignition relay circuits (page 18-11).
  - If the MIL comes on for a few seconds and goes off, go to step 2.

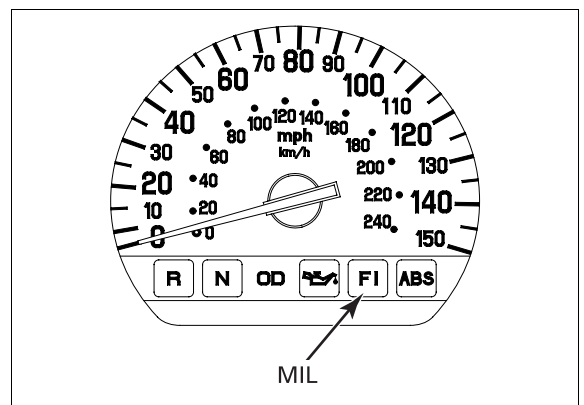

## IGNITION SYSTEM

2. Measure the voltage between the Black/yellow wire terminal (+) of the ignition coil 4P connector and ground (-). There should be battery voltage.

  - If there is no voltage, repair the open circuit in the Black/yellow wire between the ignition coil and PGM-FI ignition relay.

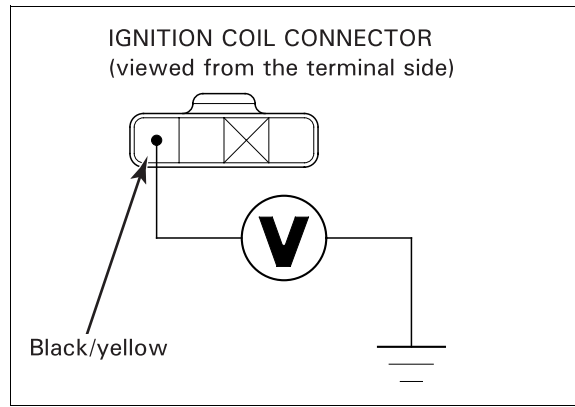

### GROUND LINE

Check for continuity between the Green wire terminal of the ignition coil 4P connector and ground. There should be continuity.

- If there is no continuity, repair the open circuit in the Green wire between the ignition coil and ground terminal.

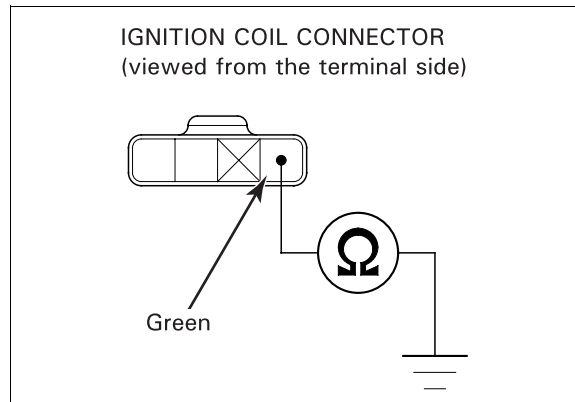

### REPLACEMENT

Remove the center inner fairing (page 2-10).

Remove the evaporative emission (EVAP) purge control solenoid valve from the stay.  
Disconnect the ignition coil 4P connectors.

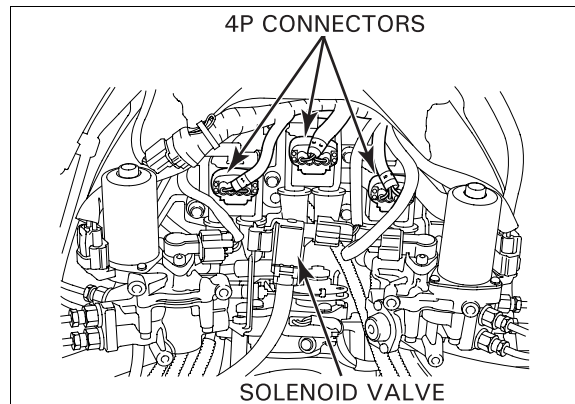

Disconnect the spark plug wires from the ignition coils.

Remove the bolts and ignition coils from the stay.

*Connect the spark plug wires to the ignition coils properly (page 1-23).*

Install the ignition coils in the reverse order of removal.

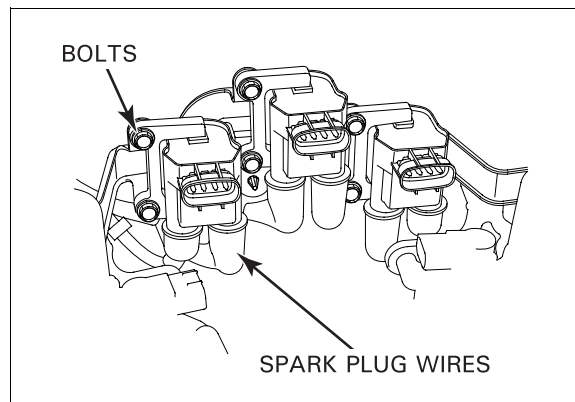

## SPARK PLUG WIRE

Disconnect the spark plug wires from the ignition coils.  
 Remove the No. 3 & 4 ignition coil.  
 Remove the wire clamp from the stay and remove the stay from the No. 2 and No. 5 spark plug wires.

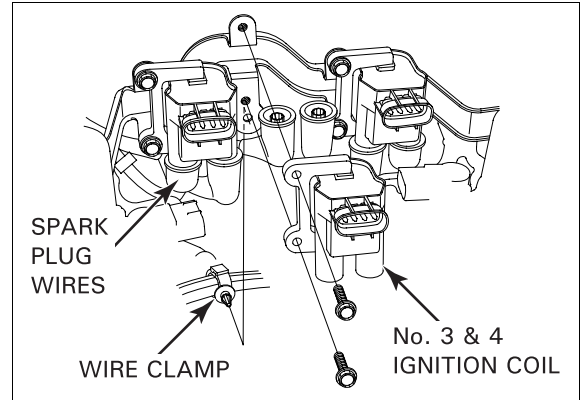

Remove the cylinder head side covers (page 3-7).  
 Disconnect the spark plug caps from the plugs (page 3-8).

Remove the bolts, front lower inner cover, wire clamps and the spark plug wires.

Route the spark plug wires properly (page 1-23) and install the removed parts in the reverse order of removal.

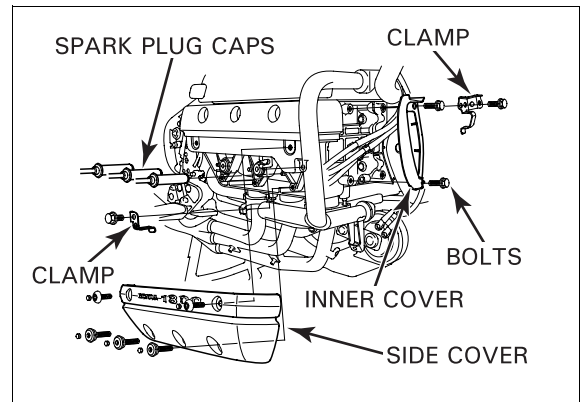

## IGNITION PULSE GENERATOR

### REPLACEMENT

Remove the following:

- front lower fairing (page 2-6)
- air cleaner housing (page 5-57)

Disconnect the ignition pulse generator 2P red connector.



Remove the 12 bolts and the crankcase front cover.  
 Remove the dowel pins and gasket.

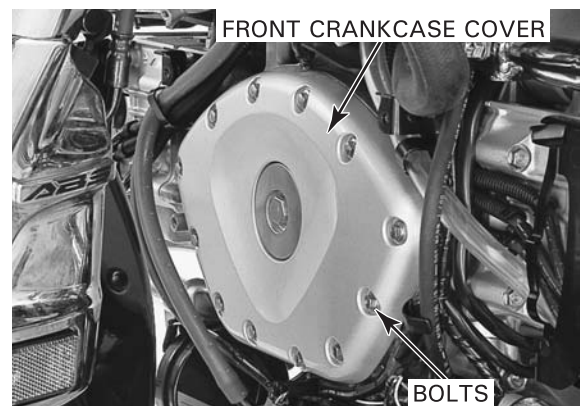

## IGNITION SYSTEM

Remove the two bolts, wire retainer, grommet and the ignition pulse generator from the front crankcase cover.

Clean the gasket mating surfaces of the crankcase and cover thoroughly, being careful not to damage them.

Apply sealant to the grommet seating surface of a new ignition pulse generator.

Apply locking agent to the bolt threads.

Install the ignition pulse generator, grommet and wire retainer onto the crankcase cover and tighten the bolts.

**TORQUE: 12 N·m (1.2 kgf·m, 9 lbf·ft)**

Install the dowel pins and a new gasket.

Apply sealant to the mating surface of the crankcase as shown.

Install the front crankcase cover and tighten the 12 bolts.

**TORQUE: 12 N·m (1.2 kgf·m, 9 lbf·ft)**

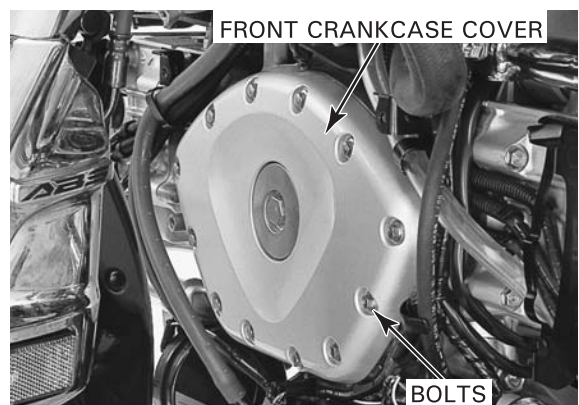
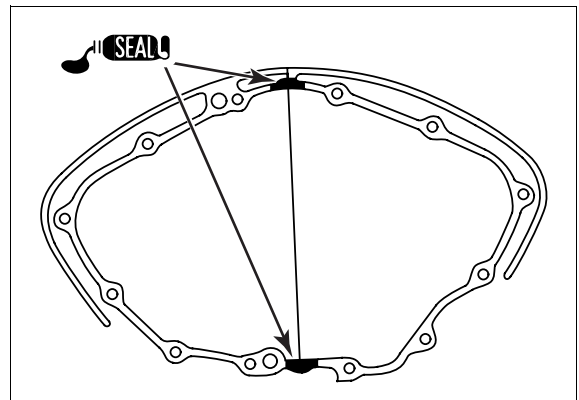
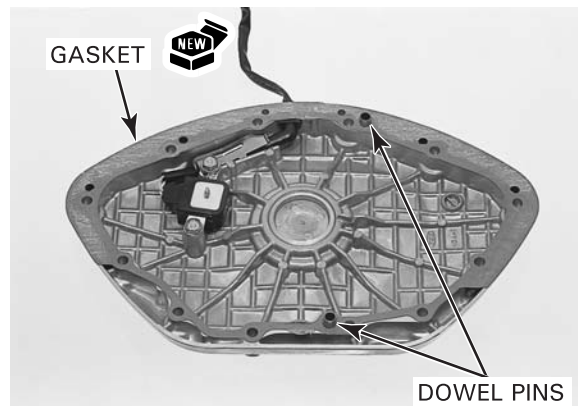
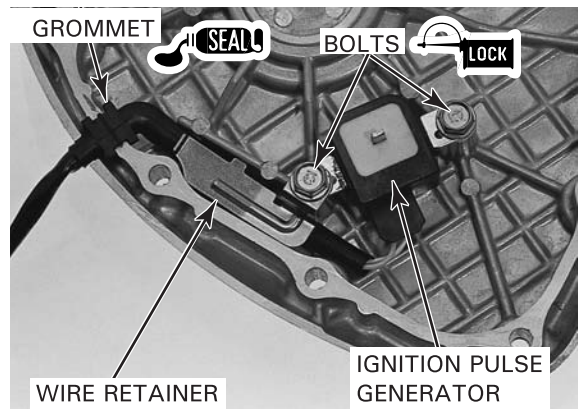

Connect the ignition pulse generator 2P red connector securely.

Install the following:

- air cleaner housing (page 5-57)
- front lower fairing (page 2-6)

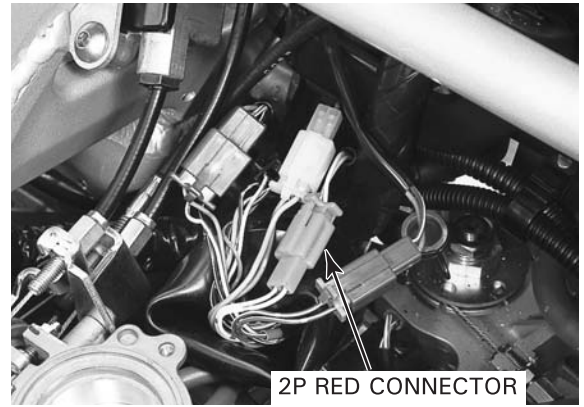

## **PGM-FI IGNITION RELAY**

### **SYSTEM INSPECTION**

NOTE:

- If the PGM-FI malfunction indicator lamp (MIL) stays on and there is no ignition coil input voltage, perform this inspection.

Remove the seat (page 2-5).

Remove the two screws and remove the relay box. Remove the relay blocks from the relay box.



1. Turn the ignition switch to "OFF" and exchange the PGM-FI ignition relay with the other good one. Turn the ignition switch to "ON" and check the MIL.
  - If the MIL comes on for a few seconds and goes off, replace the PGM-FI ignition relay with a new one.
  - If the MIL stays on, go to step 2.

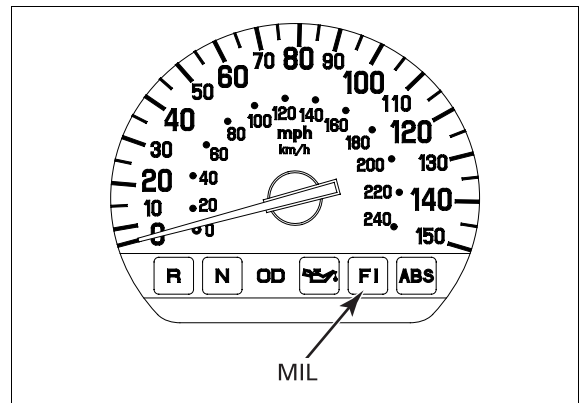



## IGNITION SYSTEM

2. Turn the ignition switch to "OFF" and remove the PGM-FI IGNITION relay.  
Turn ignition switch to "ON."  
Measure the voltage between the Black wire terminal (+) of the relay connector and ground (-).  
There should be battery voltage.
- If there is no battery voltage, go to step 3.
  - If there is battery voltage, go to step 4.

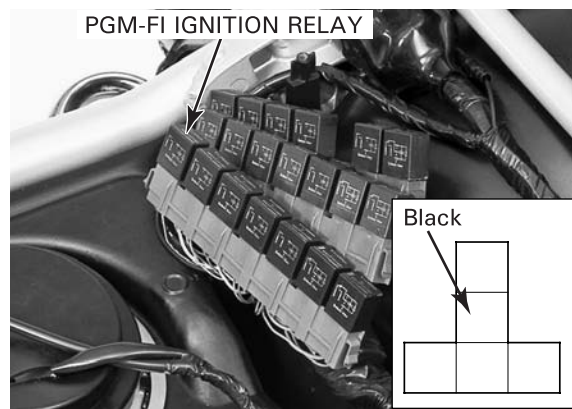

*Make sure the engine stop switch is turned to "O."*

3. Turn the ignition switch to "OFF."  
Remove the right side cover (page 2-5).  
Remove the fuse box cover.  
Check the No. 17 fuse (20 A).
- If the fuse is OK, repair the open circuit in the Black wire between the fuse box and relay box.
  - If the fuse is blown, replace it with a new one, install the PGM-FI ignition relay and turn the ignition switch to "ON." If the fuse blows again, check for a short circuit in the related wires.

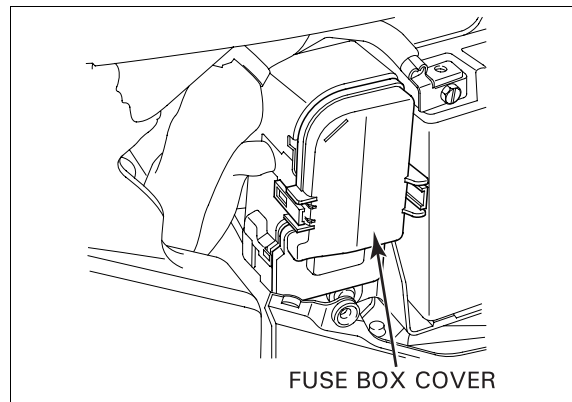

4. Measure the voltage between the Black/white wire terminal (+) of the relay connector and ground (-).  
There should be battery voltage.
- If there is no battery voltage, check the Black/white wire at the engine stop switch (page 20-35).
  - If there is battery voltage, go to step 5.

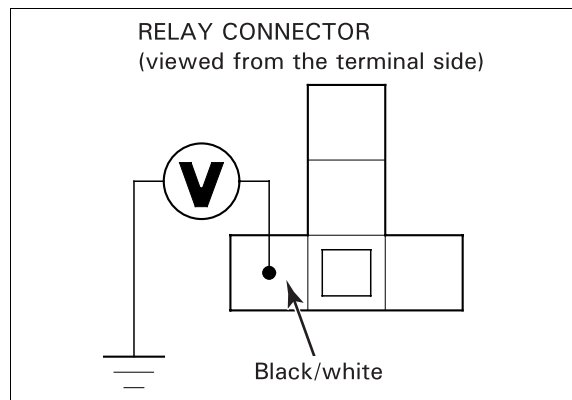

5. Check for continuity between the Red/white wire terminal of the relay connector and ground.  
There should be continuity with the ignition switch turned to "ON."
- If there is continuity, the system is OK; check for loose contacts or corroded terminals.
  - If there is no continuity, check the bank angle sensor (page 18-13).

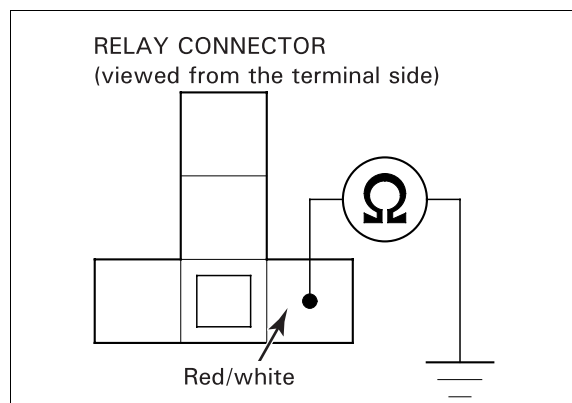



# BANK ANGLE SENSOR

## INSPECTION

1. Remove the front fairing (page 2-10).

Check for continuity between the Green wire terminal of the wire harness side bank angle sensor 3P green connector and ground. There should be continuity.

- If there is no continuity, check for an open circuit in the Green wire between the bank angle sensor connector and ground terminal.
- If there is continuity, go to step 2.

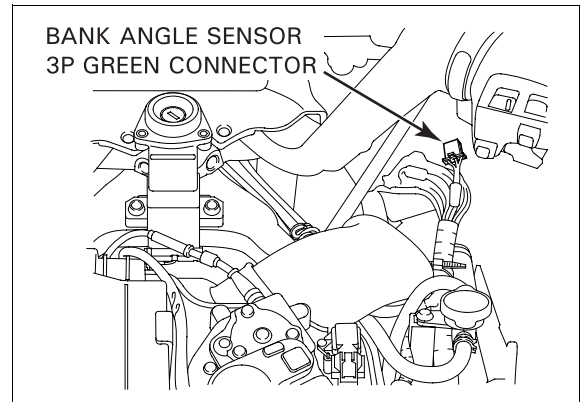

2. Turn the ignition switch to "ON."  
Measure the voltage between the Red/white wire terminal (+) of the wire harness side connector and ground (-). There should be battery voltage.

- If there is no voltage, check for an open circuit in the Red/white wire.
- If there is battery voltage, go to step 3.

3. Measure the voltage between the White wire terminal (+) of the wire harness side connector and ground (-). There should be battery voltage.

- If there is no voltage, check for an open circuit in the White wire.
- If there is battery voltage, go to step 4.

4. Remove the two screws and the bank angle sensor assembly from the right headlight.

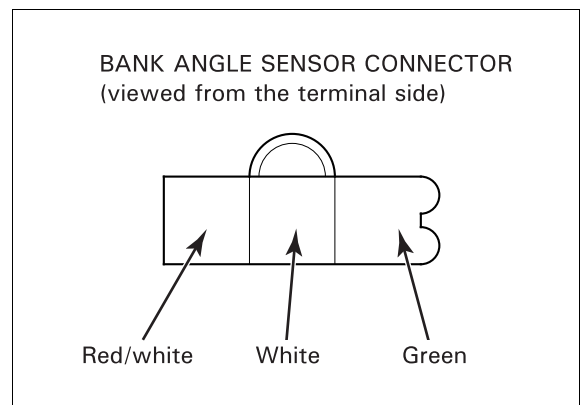

5. Turn the ignition switch to "OFF."  
Connect the bank angle sensor connector.  
Measure the voltage between the Red/white (+) and Green (-) wire terminals.

- Place the bank angle sensor horizontal and turn the ignition switch to "ON."  
There should be 0 – 1 V.
- Angle the sensor approximately 43 degrees to the left or right with the ignition switch to "ON."  
There should be battery voltage.

**NOTE:**

- If you repeat this test, first turn the ignition switch to "OFF," then back to "ON" before you try the test again.

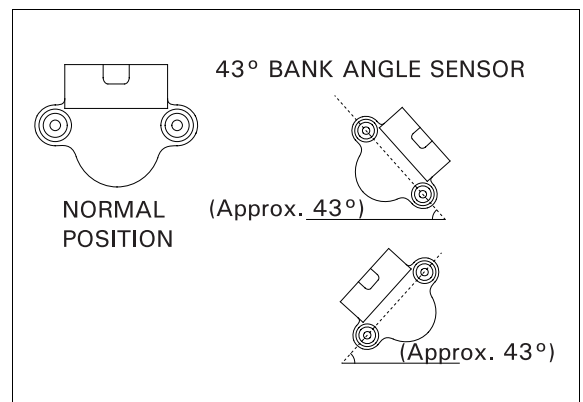
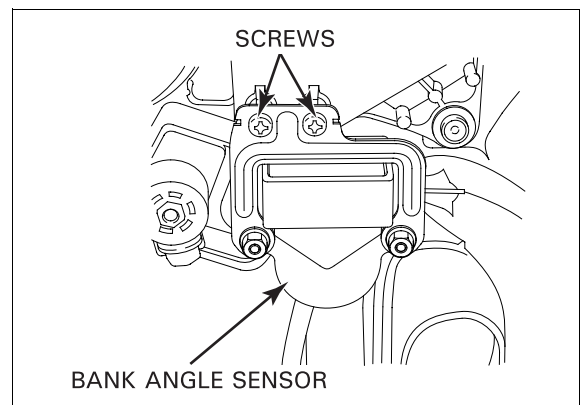

## IGNITION SYSTEM

### IGNITION TIMING

Start the engine, warm it up to normal operating temperature and stop it.  
Remove the left or right cylinder head side cover (page 3-8)  
Remove the timing hole cap (page 3-9).

*Read the manufacturer's instructions for timing light operation.*

Connect the timing light to the No. 1 or No. 2 spark plug wire.

Start the engine, let it idle and check the ignition timing.

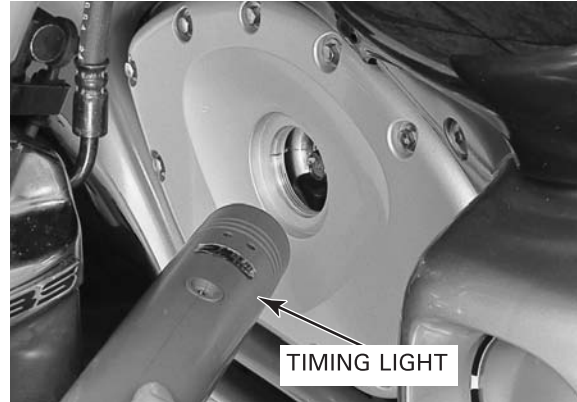

The timing is correct if the F1.2 mark on the ignition pulse generator rotor aligns with the index mark on the front crankcase cover.

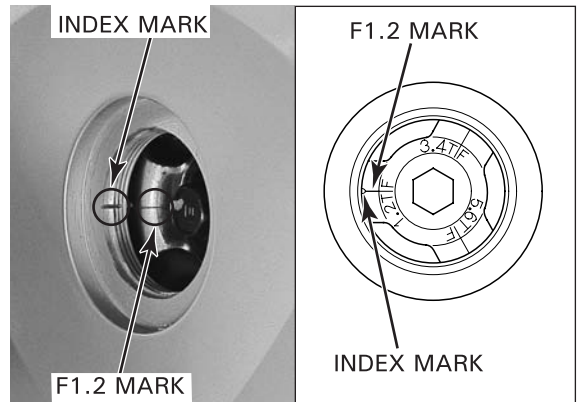

Connect the timing light to the No. 3 or No. 4 spark plug wire and check the ignition timing as previously described by observing the F3.4 mark.

Check the No. 5 or No. 6 cylinder ignition timing in the same way, using the F5.6 mark.

Remove the timing light and install the following:

- cylinder head side cover (page 3-7)
- timing hole cap (page 3-9)

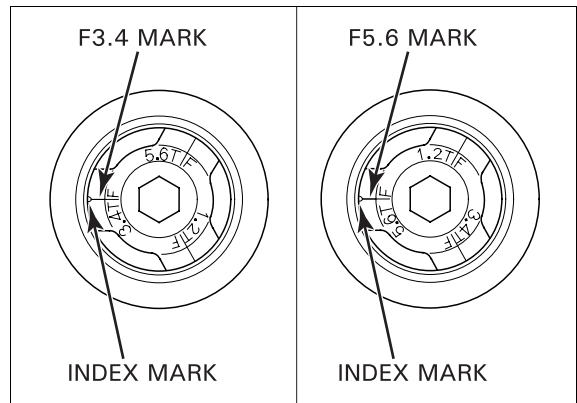

# 19. STARTER/REVERSE SYSTEM

---

SYSTEM LOCATION.....	19-2	REVERSE SWITCH .....	19-27
STARTER SYSTEM DIAGRAM .....	19-2	REVERSE REGULATOR ASSEMBLY.....	19-28
REVERSE SYSTEM DIAGRAM .....	19-3	REVERSE RESISTOR ASSEMBLY .....	19-30
SERVICE INFORMATION .....	19-4	POWER CONTROL RELAY .....	19-31
TROUBLESHOOTING .....	19-6	SPEED LIMITER RELAY.....	19-33
STARTER/REVERSE MOTOR .....	19-17	REVERSE SHIFT RELAY.....	19-34
STARTER RELAY SWITCH A .....	19-24	REVERSE SHIFT ACTUATOR .....	19-36
STARTER RELAY SWITCH B.....	19-25	CRUISE/REVERSE CONTROL MODULE .....	19-39
REVERSE RELAY .....	19-26	REVERSE SHIFT MECHANISM.....	19-42

# STARTER/REVERSE SYSTEM

## SYSTEM LOCATION

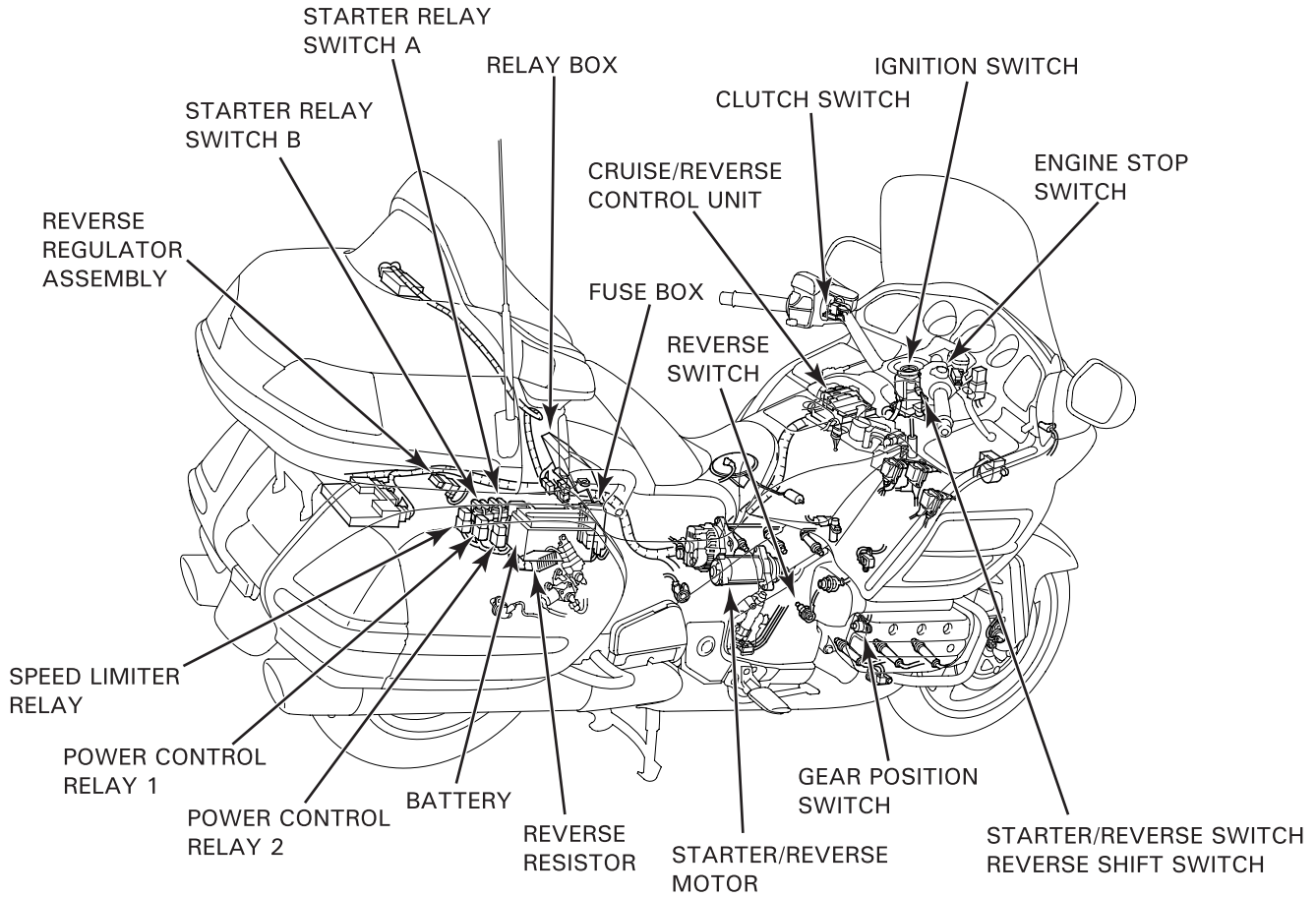

## STARTER SYSTEM DIAGRAM

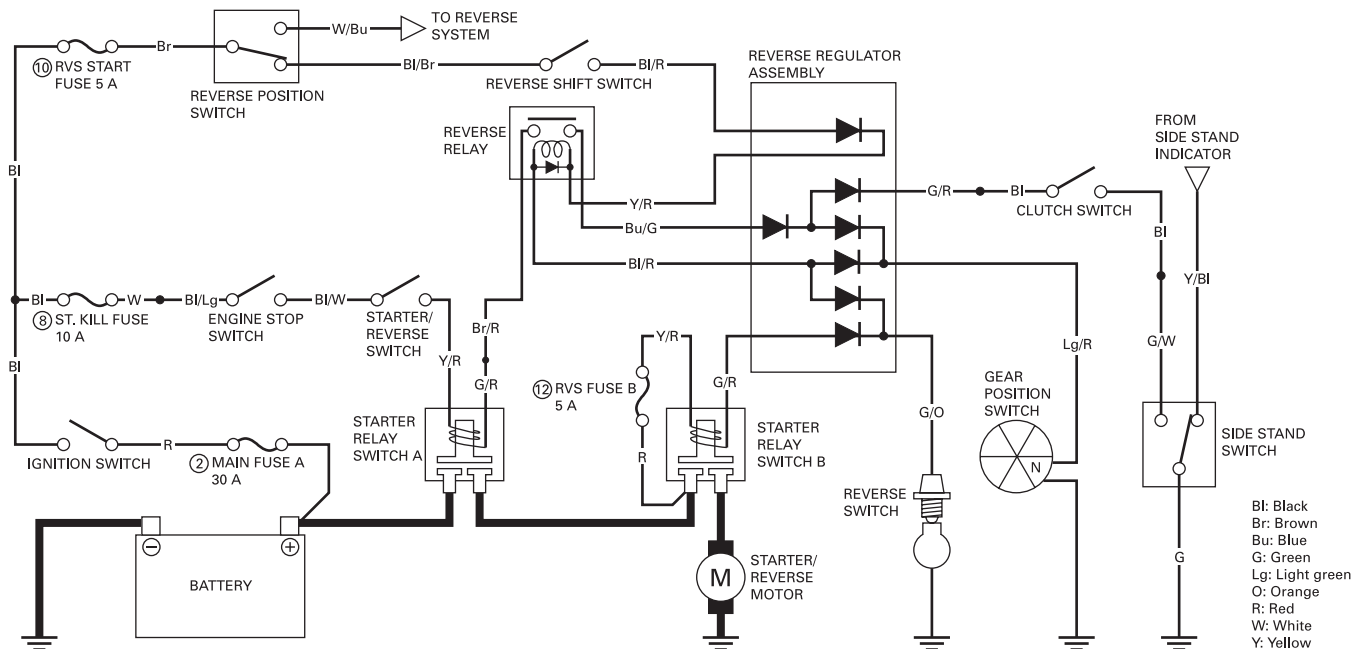

REVERSE SYSTEM DIAGRAM

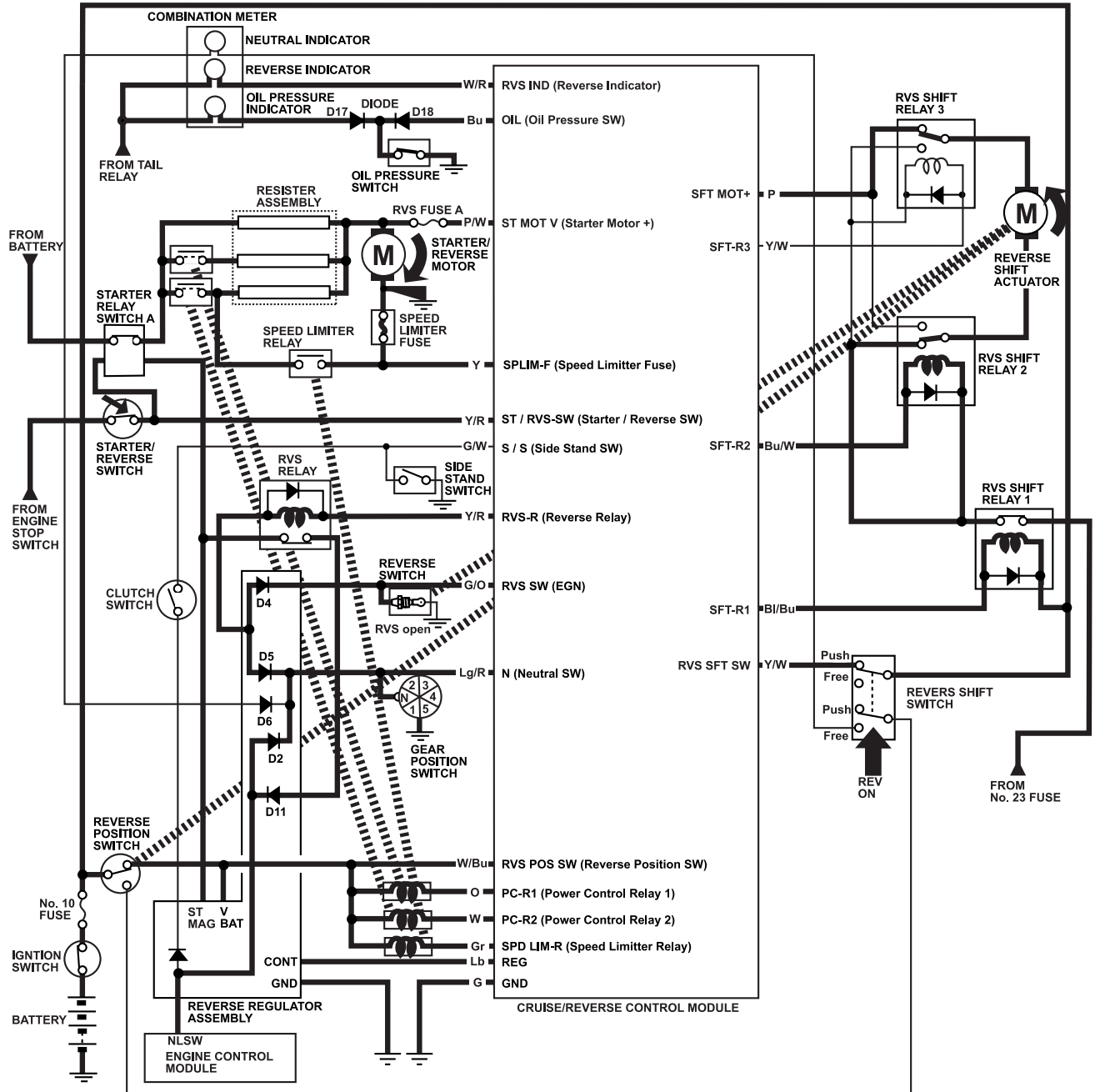

## STARTER/REVERSE SYSTEM

# SERVICE INFORMATION

### GENERAL

- Always turn the ignition switch to "OFF" before servicing the starter/reverse motor. The motor could suddenly start, causing serious injury.
- The starter/reverse motor can be serviced with the engine in the frame.
- When checking the starter/reverse system, always follow the steps in the troubleshooting flow chart (page 19-6).
- A weak battery may be unable to turn the starter/reverse motor quickly enough, or supply adequate ignition current.
- If current flows through the starter/reverse motor to turn it while the engine is not cranking over, the starter/reverse motor may be damaged.
- When the speed limiter is activated during reverse running, followed by the electrical motor brake, the motorcycle stops running in reverse and the reverse indicator goes out. To use reverse again, it is necessary to push the reverse shift switch to "OFF," then push it to "ON."
- See section 10 for starter clutch servicing.
- See section 19 for following components:
  - ignition switch
  - engine stop switch
  - starter/reverse switch
  - reverse shift switch
  - clutch switch
  - side stand switch
  - gear position switch

### SPECIFICATIONS







ITEM		STANDARD	SERVICE LIMIT
Starter/reverse motor brush length		12.5 mm (0.49 in)	6.0 mm (0.24 in)
Reverse resistor resistance (20° C/68° F)	Red and black terminal	0.20 – 0.25 $\Omega$	–
	White terminal	0.15 – 0.20 $\Omega$	–

### TORQUE VALUES

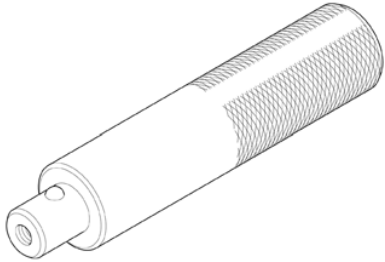
Starter/reverse motor mounting bolt	29 N·m (3.0 kgf·m, 22 lbf·ft)	
Reverse switch	12 N·m (1.2 kgf·m, 9 lbf·ft)	
Reverse switch terminal nut	2 N·m (0.2 kgf·m, 1.4 lbf·ft)	
Shift drum lock arm bolt	12 N·m (1.2 kgf·m, 9 lbf·ft)	Apply locking agent to the threads.
Reverse shifter shaft bolt	14 N·m (1.4 kgf·m, 10 lbf·ft)	Apply locking agent to the threads.
Reverse shifter cable holder bolt	12 N·m (1.2 kgf·m, 9 lbf·ft)	Apply locking agent to the threads.

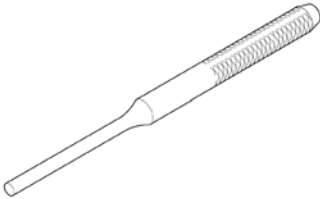
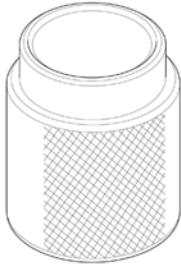
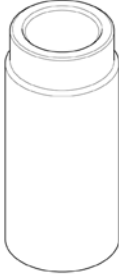

**TOOLS**

<p>Driver 07749-0010000</p> 	<p>Attachment, 24 x 26 mm 07746-0010700</p> 	<p>Attachment, 32 x 35 mm 07746-0010100</p> 
<p>Attachment, 37 x 40 mm 07746-0010200</p> 	<p>Attachment, 20 mm I.D. 07746-0020400</p>  <p>or equivalent commercially available in U.S.A.</p>	<p>Pilot, 20 mm 07746-0040500</p> 
<p>Pin driver, 3.5 mm 07744-0010300</p>  <p>or equivalent commercially available in U.S.A.</p>	<p>Fork seal driver 07947-4630100</p> 	<p>Assembly collar 07965-VM00100</p> 

# TROUBLESHOOTING

### Starter/reverse motor will not turn for starting

#### 1. Battery Power to Starter Relay Switch A Inspection

- Check that the battery is fully charged and in good condition.
- Make sure the reverse shift switch is pushed to "OFF" (neutral position).
- Check for a blown No. 8 ST. KILL fuse, No. 10 RVS START fuse (5 A) or No. 12 RVS fuse B (5 A).

Remove the left saddlebag (page 2-15).

Check for a loose or poorly connected battery cable, and an open circuit in the battery cable between the battery and starter relay switch A.

#### *Are all connections between the battery and the starter relay good?*

- NO** – • Poorly connected battery cable.  
• Open circuit in the battery cable.

**YES** – GO TO STEP 2.

#### 2. Starter Relay Switch A Connection Inspection

Check for loose or poorly connected cable terminal at starter relay switch A.

#### *Is the cable connection good?*

- NO** – Poorly connected terminals.

**YES** – GO TO STEP 3.

#### 3. Starter Relay Switch B Power Supply and Connection Inspection

Check for loose or poorly connected cable terminals at starter relay switch B, and an open circuit in the starter relay switch cable between starter relay switches A and B.

#### *Are all connections between starter relay switches A and B good?*

- NO** – • Poorly connected terminals.  
• Open circuit in the starter relay switch cable.

**YES** – GO TO STEP 4.

#### 4. Starter Relay Switches A & B Operation Inspection

With the ignition switch turned to "ON" and the engine stop switch to "⏏", push the starter/reverse switch and check for a "click" sound from starter relay switches A and B. Both switches should click.

#### *Do both switches click?*

- NO** – • If both relay switches do not click, GO TO STEP 7.  
• If starter relay switch A clicks but switch B does not click, GO TO STEP 10.

**YES** – GO TO STEP 5.

#### 5. Starter Motor Power Supply and Connection Inspection

Remove the fuel tank (page 5-56).

Check for loose or poorly connected cable terminals at the starter motor, and an open circuit in the starter motor cable between starter relay switch B and the starter motor.

#### *Is the circuit between the starter relay switch B and the starter motor, and all connections at the starter motor good?*

- NO** – • Poorly connected terminal.  
• Open circuit in the starter motor cable.

**YES** – GO TO STEP 6.

#### 6. Starter Motor Operation Inspection

Connect the starter motor terminal directly to the battery positive terminal. (Because a large amount of current flows, DO NOT USE A THIN WIRE.)

#### *Does the motor turn?*

- NO** – Faulty starter motor.

**YES** – Faulty starter relay switch B.

### 7. Starter Relay Switch A Relay Coil Control Line Continuity Inspection

Check the relay coil ground line of starter relay switch A (page 19-24).

**Is there continuity?**

- NO** – • Open circuit in the Brown/red wire between starter relay switch A and the reverse relay.  
• Loose or poor contact of the reverse relay connector.  
• Faulty reverse relay or its circuits (page 19-26)

**YES** – GO TO STEP 8.

### 8. Starter Relay Switch A Relay Coil Voltage Line Inspection

Check the relay coil input voltage line of starter relay switch A (page 19-24).

**Is battery voltage present when the starter/reverse switch is pushed in?**

- NO** – • Open circuit in the Yellow/red wire between starter relay switch A and right handlebar switch.  
• Loose or poor contact of the handlebar switch connector.  
• Faulty right handlebar (starter/reverse) switch (page 20-35).  
• Open circuit in the White wire between the right handlebar switch and fuse box (No. 8 ST. KILL fuse).

**YES** – GO TO STEP 9.

### 9. Starter Relay Switch A Operation Inspection

Check the operation of starter relay switch A (page 19-24).

**Is there continuity between the cable terminals while the battery is connected, and no continuity when the battery is disconnected?**

**NO** – Faulty starter relay switch A.

**YES** – Loose or poor contact of the starter relay switch A 2P red connector.

## STARTER/REVERSE SYSTEM

---

### 10. Starter Relay Switch B Relay Coil Control Line Continuity Inspection

Check the relay coil ground line of starter relay switch B (page 19-25).

**Is there continuity?**

- NO** –
- Open circuit in the Green/red wire between starter relay switch B and reverse regulator assembly.
  - Open circuit in the Green/orange wire between the reverse regulator assembly and reverse switch.
  - Loose or poor contact of the reverse regulator assembly connector.
  - Faulty reverse regulator assembly (diode) (page 19-28).
  - Faulty reverse switch (page 19-27).

**YES** – GO TO STEP 11.

### 11. Starter Relay Switch B Relay Coil Voltage Line Inspection

Check the relay coil input voltage line of starter relay switch B (page 19-25).

**Is battery voltage present only when the starter/reverse switch is pushed in?**

- NO** –
- Open circuit in the Red wire between starter relay switch A and the fuse box (No. 12 reverse fuse B)
  - Open circuit in the Yellow/red wire between starter relay switch B and the fuse box (No. 12 reverse fuse B).
  - Faulty starter relay switch A.

**YES** – GO TO STEP 12.

### 12. Starter Relay Switch B Operation Inspection

Check the operation of starter relay switch B (page 19-25).

**Is there continuity between the cable terminals while the battery is connected, and no continuity when the battery is disconnected?**

**NO** – Faulty starter relay switch B.

**YES** – Loose or poor contact of the starter relay switch B 2P white connector.

#### **Starter motor turns slowly**

- Weak battery
- Poorly connected battery cable
- Poorly connected starter motor cable
- Faulty starter motor

#### **Starter motor turns, but engine does not turn**

- Faulty starter clutch (section 10)

#### **Starter relay switch “clicks,” but engine does not turn over**

- Crankshaft does not turn due to engine problem
- Faulty starter drive or driven gear
- Faulty starter idle gear

**Reverse shift actuator will not turn to the reverse position when the reverse shift switch is pushed to "ON"**

### 1. Reverse Shift Actuator Operation Inspection

- Check for a blown No. 23 RVS SHIFT fuse A (15 A).
- Check that the neutral indicator comes on when the ignition switch is turned to "ON" with the transmission in neutral.
- Check that the reverse shift actuator cables are adjusted properly (page 19-36).
- Make sure the motorcycle is stopped.

With the motorcycle stopped, shift the transmission into neutral and turn the ignition switch to "ON."

Push the reverse shift switch to "ON" and check that the reverse actuator operates.

***Does the reverse actuator operate?***

**YES** – GO TO STEP 13.

**NO** – GO TO STEP 2.

### 2. Reverse Indicator Operation Inspection

Check that the reverse indicator is blinking.

***Does the reverse indicator blink?***

**NO** – GO TO STEP 10.

**YES** – GO TO STEP 3.

### 3. Reverse Shift Relay Inspection

Check the reverse shift relay system (page 19-34).

***Does the reverse shift relay system test OK?***

**NO** – Faulty reverse shift relay(s) or related circuit.

**YES** – GO TO STEP 4.

### 4. Reverse Shift Relay 1 Coil Control Line Voltage Inspection

Check the reverse shift relay 1 coil (No. 40) circuit at the cruise/reverse control module (page 19-39).

***Is battery voltage present when tested as described?***

**NO** – Open circuit in the Blue/black wire between the control module and reverse shift relay 1.

**YES** – GO TO STEP 5.

### 5. Reverse Shift Relay 2 Coil Voltage/Control Line Continuity Inspection

Check the reverse shift relay 2 coil (No. 34) circuit at the cruise/reverse control module (page 19-39).

***Is continuity correct?***

**NO** – • Open circuit in the Blue/white wire between the control module and reverse shift relay 2.  
• Open circuit in the Red wire between reverse shift relays 1 and 2.

**YES** – GO TO STEP 6.

### 6. Reverse Shift Relay 3 Coil Control Line Continuity Inspection

Check the reverse shift relay 3 coil (No. 27) circuit at the cruise/reverse control module (page 19-39).

***Is continuity correct?***

**NO** – Short circuit in the Yellow/white wire between the control module and reverse shift relay 3.

**YES** – GO TO STEP 7.

### 7. Reverse Actuator/Shift Relay Ground Line Continuity Inspection

Check the reverse shift motor (+) (No. 1) circuit at the cruise/reverse control module (page 19-39).

***Is there continuity?***

**NO** – Open circuit in the Pink wire between the control module and reverse shift relay 3.

**YES** – GO TO STEP 8.

## STARTER/REVERSE SYSTEM

---

### 8. Reverse Shift Motor Ground Line Continuity Inspection

Check the reverse shift motor (-) (No. 8) circuit at the cruise/reverse control module (page 19-39).

***Is there continuity?***

**NO** – Open circuit in the Green wire between the control module and ground terminal.

**YES** – GO TO STEP 9.

### 9. Reverse Shift Actuator Motor Inspection

Check the reverse shift actuator (page 19-36)

***Does the reverse shift actuator test OK?***

**NO** – Faulty reverse shift actuator motor and related circuits.

**YES** – Faulty cruise/reverse control module.

### 10. Gear Position Neutral Line Continuity Inspection

Check the gear position (neutral) switch (No. 47) circuit at the cruise/reverse control module (page 19-39).

***Is there continuity?***

**NO** – Open circuit in the Light green/red wire between the control module and gear position switch.

**YES** – GO TO STEP 11.

### 11. Reverse Shift Switch Line Voltage Inspection

Check the reverse shift switch (No. 23) circuit at the cruise/reverse control module (page 19-39).

***Is battery voltage present?***

**NO** – • Open circuit in the Yellow/white wire between the control module and right handlebar switch.  
• Faulty right handlebar switch (reverse shift switch).

**YES** – GO TO STEP 12.

### 12. Cruise/Reverse Control Module Ground Line Continuity Inspection

Check the ground (No. 20 and 52) circuits at the cruise/reverse control module (page 19-39).

***Is there continuity?***

**NO** – Open circuit in the Green wire between the control module and ground terminal.

**YES** – Faulty cruise/reverse control module.



**13. Reverse Indicator Operation Inspection**

Check the reverse indicator.

***Does the reverse indicator light blink?***

- NO** – If the indicator light comes on and does not blink, the system is normal.  
– If the indicator light does not come on, perform the troubleshooting on page 19-11.
- YES** – GO TO STEP 14.

**14. Reverse Position Switch Signal Line Voltage Inspection**

Check the reverse position switch (No. 25) circuit at the cruise/reverse control module page 19-39.

***Is battery voltage present?***

- NO** – Open circuit in the White/blue wire between the control module and reverse shift actuator.
- YES** – GO TO STEP 15.

**15. Reverse Switch Line Continuity Inspection**

Check the reverse switch (No. 17) circuit at the cruise/reverse control module (page 19-39).

***Is continuity correct?***

- NO** – Short circuit in the Green/orange wire between the control module and reverse switch.
- YES** – Faulty cruise/reverse control module.

**Reverse shift actuator operates but the reverse indicator does not come on****1. Oil Pressure and Side Stand Indicator Operation Inspection**

Check for blown speed limiter fuse (70 A).  
Check that the oil pressure and side stand indicators function properly.

***Do the oil pressure and side stand indicators function properly?***

- NO** – Check the combination meter power input line (page 20-17).
- YES** – GO TO STEP 2.

**2. Reverse Indicator Operation Inspection**

Check the reverse indicator (No. 24) circuit at the cruise/reverse control module (page 19-39).

***Does the reverse indicator come on?***

- NO** – • Open circuit in the White/red wire between the cruise/reverse control module and combination meter.  
• Loose or poor contact of the related connectors.  
• Faulty combination meter.
- YES** – GO TO STEP 3.

**3. Speed Limiter Line Continuity Inspection**

Check the speed limiter fuse (No. 19) circuit at the cruise/reverse control module (page 19-39).

***Is there continuity?***

- NO** – Open circuit in the Yellow wire between the control module and fuse box (reverse limiter fuse).
- YES** – Faulty cruise/reverse control module.

## STARTER/REVERSE SYSTEM

Reverse shift actuator will not turn to the neutral position when the reverse shift switch is pushed to "OFF"

### 1. Neutral Indicator Operation Inspection

Turn the ignition switch to "OFF" and push the reverse shift switch to "OFF."

Turn the ignition switch to "ON" and check that the reverse shift actuator turns to the neutral position and the neutral indicator comes on.

**Does the neutral indicator come on?**

**YES** – The system is normal.

**NO** – GO TO STEP 2.

### 2. Reverse Actuator Operation Inspection - Reverse Position

Turn the ignition switch to "OFF" and remove the center inner fairing (page 2-10).

Return the reverse shift actuator to the neutral position by turning the pulley clockwise using a 22 mm wrench.

If the pulley cannot be turned, check the reverse shift actuator (page 19-36). If the actuator is OK, check the reverse shift mechanism (page 19-42).

Turn the ignition switch to "ON" and push the reverse shift switch to "ON" position.

Check that the reverse actuator turns to the reverse position and the reverse indicator comes on.

**Does the reverse actuator turn to the reverse position and the reverse indicator light come on?**

**NO** – Perform the troubleshooting on page 19-9.

**YES** – GO TO STEP 3.

### 3. Reverse Shift Relay 3 Coil Control Line Continuity Inspection

Check the reverse shift relay 3 coil (No. 27) circuit at the cruise/reverse control module (page 19-39).

**Is continuity correct?**

**NO** –

- Open circuit in the Yellow/white wire between the control module and reverse shift relay 3.
- Open circuit in the Red wire between reverse shift relays 1 and 3.

**YES** – GO TO STEP 4.

### 4. Reverse Shift Relay 2 Coil Control Line Continuity Inspection

Check the reverse shift relay 2 coil (No. 34) circuit at the cruise/reverse control module (page 19-39).

**Is continuity correct?**

**NO** – Short circuit in the Blue/white wire between the control module and reverse shift relay 2.

**YES** – Faulty cruise/reverse control module.

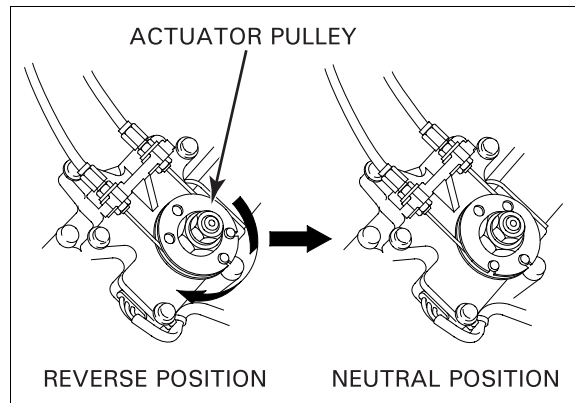

**Starter motor turns for starting but will not turn for reverse running****1. Side Stand Switch Signal Line Continuity Inspection**

- Make sure the following conditions are satisfied for reverse running:
  - engine is running
  - transmission is in neutral
  - side stand is retracted
  - reverse shift switch is pushed to “ON” and the reverse indicator illuminates.
- When the speed limiter is activated during reverse running, followed by the electrical motor brake or when the motor is overloaded more than 3 seconds, the reverse system is turned off and the reverse indicator goes out. To use reverse again, it is necessary to push the reverse shift switch to “OFF,” then push it to “ON.”

Check the side stand switch (No. 11) circuit at the cruise/reverse control module (page 19-39).

***Is continuity correct?***

**NO** – Open circuit in the Green/white wire between the cruise/reverse control module and side stand switch.

**YES** – GO TO STEP 2.

**2. Oil Pressure Switch Signal Line Continuity Inspection**

Check the oil pressure switch (No. 48) circuit at the cruise/reverse control module (page 19-39).

***Is continuity correct?***

**NO** – • Short circuit in the Blue or Blue/red wire between the control module and oil pressure switch.  
• Faulty oil pressure switch diode (D18) (page 20-13).

**YES** – GO TO STEP 3.

**3. Starter Relay Switch B Cable Continuity Inspection**

Remove the left saddlebag (page 2-15).

Check for continuity between the cable terminals at starter relay switch B. There should be continuity.

***Is there continuity?***

**NO** – • Open circuit in the Red wire between starter relay switch B and reverse resistor assembly.  
• Open circuit in the Black wire between starter relay switch B and reverse resistor assembly.  
• Loose or poor contact of the related connectors and terminal.  
• Faulty reverse resistor assembly (page 19-30).

**YES** – GO TO STEP 4.

**4. Starter Relay Switch A Relay Coil Voltage Line Inspection**

Measure the regulated voltage of the reverse regulator assembly at the starter relay switch A 2P connector (page 19-28).

***Is battery voltage present?***

**NO** – GO TO STEP 5.

**YES** – Temporary failure; the system is normal.

**5. Starter Reverse Switch Signal Line and Reverse Relay Coil Control Line Voltage Inspection**

Check the starter/reverse switch (No. 18) circuit and reverse relay (No. 43) circuit at the cruise/reverse control module (page 19-39).

***Is battery voltage present?***

**NO** – • Open circuit in the Yellow/red wire between the cruise/reverse control module and starter/reverse switch.  
• Open circuit in the Yellow/red wire between the cruise/reverse control module and reverse relay.  
• Loose or poor contact of the related connectors.

**YES** – GO TO STEP 6.

## STARTER/REVERSE SYSTEM

---

### 6. Reverse Regulator Circuit Inspection

Check the reverse regulator circuits (page 19-29).

#### ***Do the reverse regulator circuits test OK?***

- NO** –
- Open circuit in the Light blue wire between the reverse regulator assembly and cruise/reverse control module.
  - Open circuit in the Green wire between the reverse regulator assembly and ground terminal.
  - Open circuit in the White/blue wire between the reverse regulator assembly and reverse position switch (in the reverse shift actuator).
  - Open circuit in the Brown/red wire between the reverse regulator assembly and starter relay switch A.
  - Loose or poor contact of the related connectors.

**YES** – GO TO STEP 7.

### 7. Reverse Regulator Inspection

Replace the reverse regulator assembly with a known-good one and check the regulated voltage again.

#### ***Is the regulated voltage correct?***

- NO** –
- Loose or poor contact of the cruise/reverse control module connectors.
  - Faulty cruise/reverse control module.

**YES** – Faulty original reverse regulator assembly.

**Reverse running speed too slow (below 0.6 mph (1.0 km/h) on a flat road), lack of uphill power**

**1. Battery voltage Inspection**

Check the battery (page 17-6).

***Is battery voltage within the specified value?***

**NO** – • Under charged battery.  
• Faulty battery.

**YES** – GO TO STEP 2.

**2. Power Control Relay Inspection**

Check the power control relay system (page 19-31).

***Does the power control relay system test OK?***

**NO** – • Faulty power control relay circuits.  
• Faulty power control relay.

**YES** – GO TO STEP 3.

**3. Reverse Resistor Assembly Inspection**

Check the reverse resistor assembly (page 19-30).

***Is the resistance correct?***

**NO** – Faulty reverse resistor assembly.  
– Faulty cruise/reverse control module.

**Speed limiter system will not works when the reverse running speed is above 1.6 mph (2.5 km/h)**

**1. Speed Limiter Relay System Inspection**

Check the speed limiter relay system (page 19-33).

***Does the speed limiter relay system test OK?***

**NO** – • Faulty speed limiter relay circuits.  
• Faulty speed limiter relay.

**YES** – GO TO STEP 2.

**2. Speed Limiter Line Continuity Inspection**

Check the Yellow wire for continuity between the speed limiter relay connector and speed limiter fuse terminal in the fuse box.

There should be continuity

***Is there continuity?***

**NO** – Open circuit in the Yellow wire between the speed limiter relay and fuse box.

**YES** – GO TO STEP 3.

**3. Reverse Resistor Assembly Inspection**

Check the reverse resistor assembly (page 19-30).

***Is the resistance correct?***

**NO** – Faulty reverse resistor assembly.

**YES** – Faulty cruise/reverse control module.

## STARTER/REVERSE SYSTEM

---

### Motorcycle starts reverse running but stops immediately

#### 1. Voltage to Starter Motor Signal Line Continuity Inspection

Check for a blown No. 11 RVS fuse A (5 A).

Check the starter/reverse motor (No. 12) circuit at the cruise/reverse control module (page 19-39).

##### *Is there continuity?*

- NO** – • Check for open circuit in the Pink wire between starter relay switch B and reverse fuse A in the fuse box.  
• Check for an open circuit in the Pink/white wire between the cruise/reverse control module and reverse fuse B in the fuse box.
- YES** – • Loose or poor contact of the cruise/reverse control module connectors.  
• Faulty cruise/reverse control module.

### System enters the reverse mode before all reverse running conditions are satisfied

#### 1. Side Stand Switch and Oil Pressure Switch Signal Line Continuity Inspection

Check the side stand switch (No. 11) and oil pressure switch (No. 48) circuits at the cruise/reverse control module (page 19-39).

##### *Is the continuity correct?*

- NO** – • Check for a short circuit in the Green/white wire between the cruise/reverse control module and side stand switch.  
• Faulty side stand switch.  
• Check for an open circuit in the Blue or Blue/red wire between the cruise/reverse control module and oil pressure switch, or faulty diode.  
• Faulty oil pressure switch.
- YES** – Faulty cruise/reverse control module.



**STARTER/REVERSE MOTOR**

**REMOVAL**

Remove the following:

- fuel tank (page 5-56).
- reverse shift arm (page 19-42)

Slide the rubber cap off the starter motor terminal and remove the terminal nut and starter/reverse motor cable.

Remove the three starter/reverse motor mounting bolts.

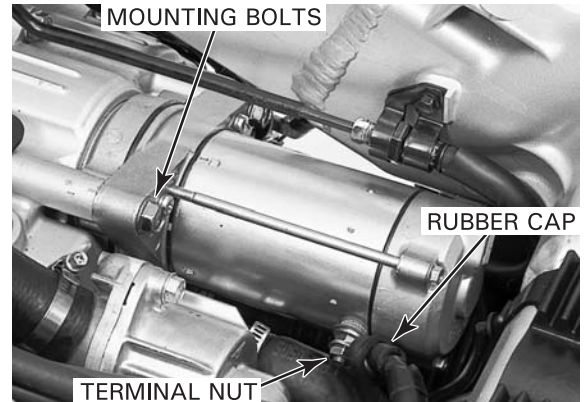

Remove the starter/reverse motor from the rear crankcase cover as shown and remove the O-ring from the starter motor.

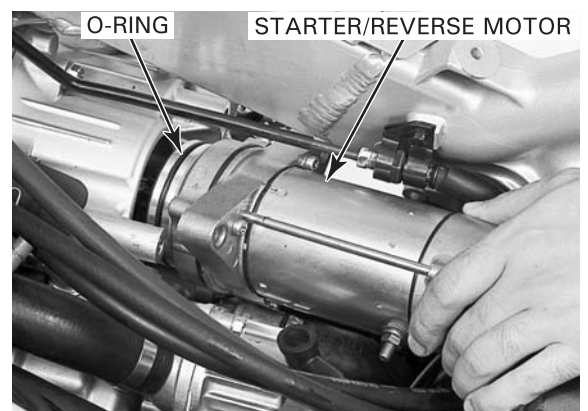

**DISASSEMBLY/INSPECTION**

Remove the three starter/reverse motor case bolts.



Remove the following:

- reduction gear case
- seal ring
- gear base washer
- gear base
- washer

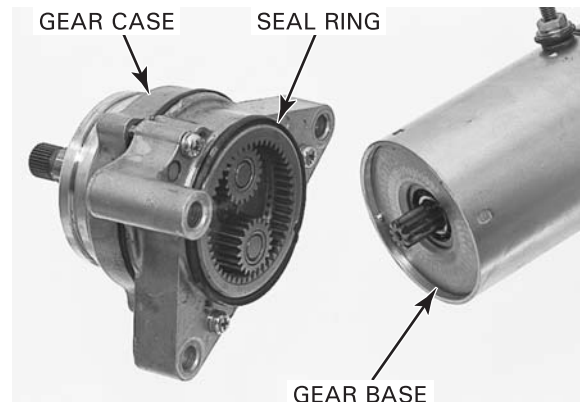

## STARTER/REVERSE SYSTEM

- rear cover
- washer
- seal ring
- armature

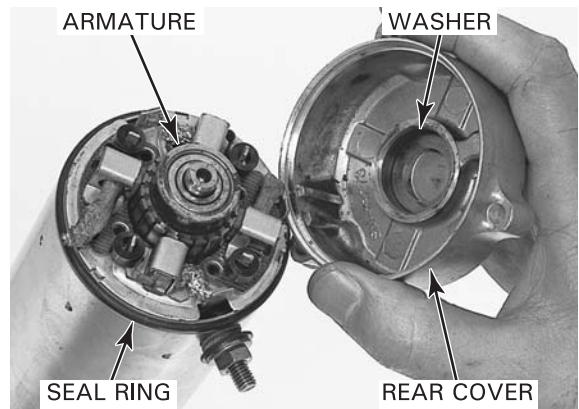

### ARMATURE

Check the commutator bars of the armature for discoloration.

#### NOTE:

- Do not use emery or sand paper on the commutator.

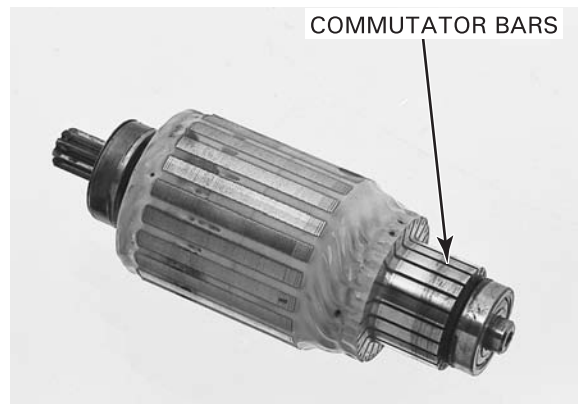

Check for continuity between pairs of commutator bars.  
There should be continuity.



Check for continuity between each commutator bar and the armature shaft.  
There should be no continuity.



### BRUSH/MOTOR CASE

Measure the brush length.

**SERVICE LIMIT: 6.0 mm (0.24 in)**

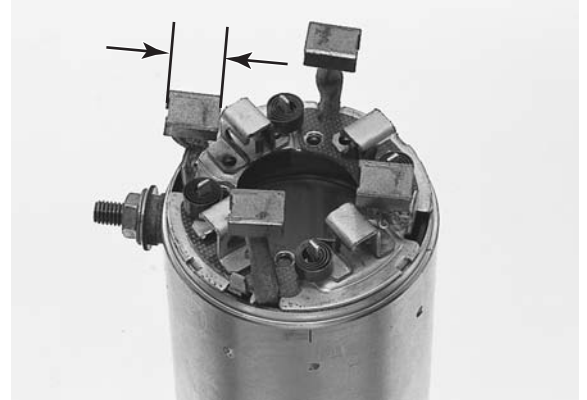

Check for continuity between the insulated brush and cable terminal.  
There should be continuity.

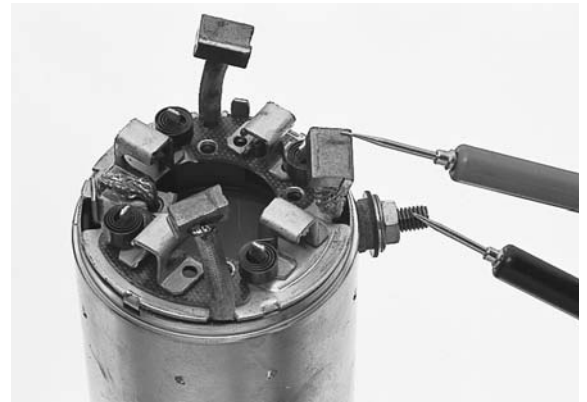

Check for continuity between the insulated brush and motor case.  
There should be no continuity.

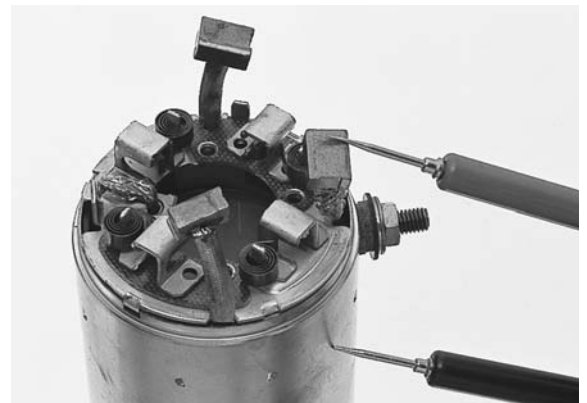

Remove the following if necessary:

- brush holder

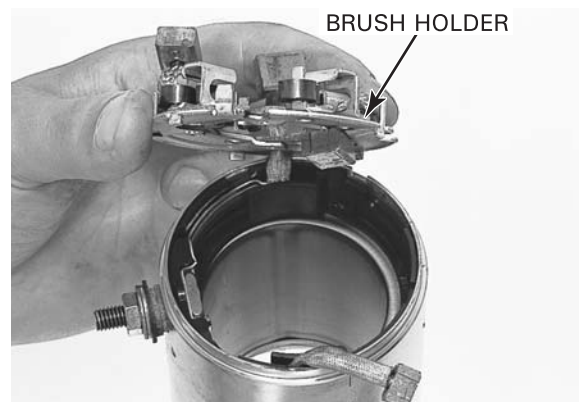

## STARTER/REVERSE SYSTEM

- nut
- washer
- insulator washers
- O-ring
- cable terminal
- insulated brush
- insulator

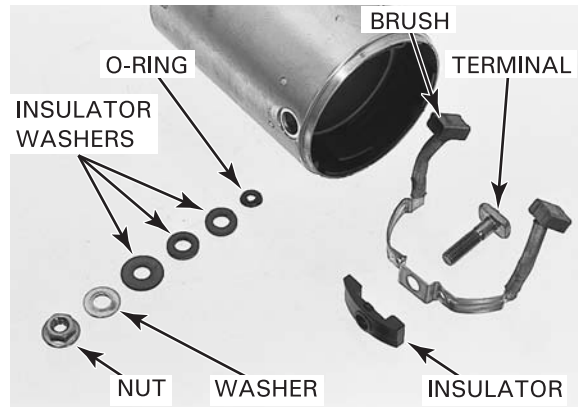

### REDUCTION GEAR CASE

Check the reverse drive gear for excessive or abnormal wear.

Remove the snap ring and washers from the starter shaft.

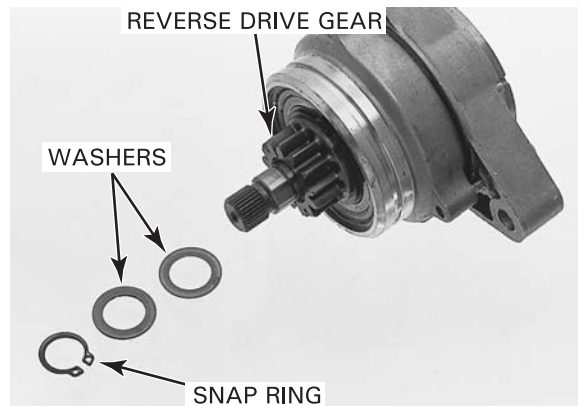

Remove the reduction gears and dowel pin.

Check the starter reduction gears for excessive or abnormal wear.

Remove the three screws.

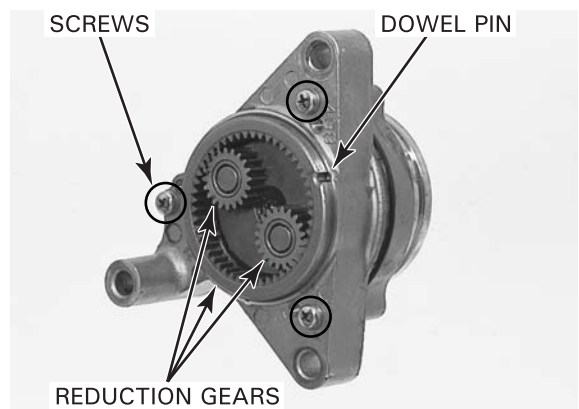

Separate the starter and reverse reduction gear cases.

Remove the seal ring.

Remove the gear holder.

Check the reverse reduction gears for excessive or abnormal wear.

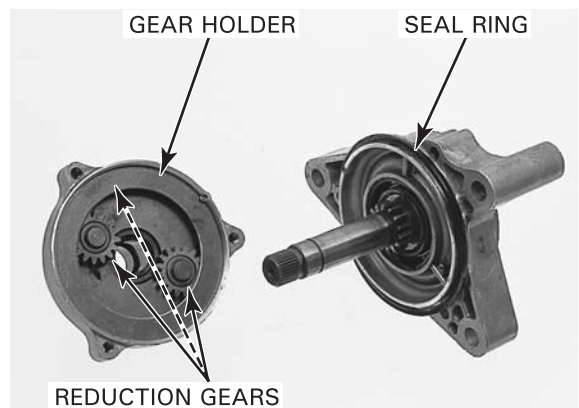

**ASSEMBLY**

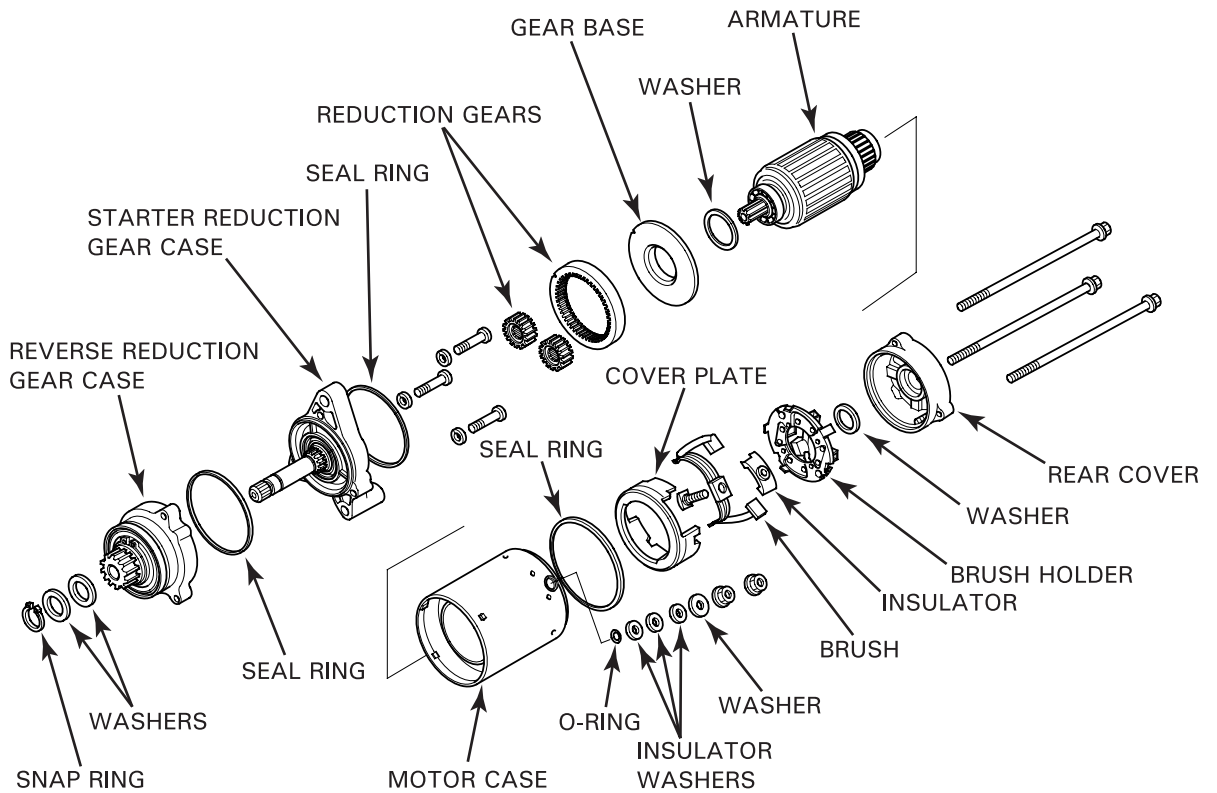

Apply molybdenum disulfide grease to the reverse reduction gears.  
 Install the gear holder, aligning the groove with the dowel pin.  
 Install a new seal ring.  
 Assemble the reduction gear cases, aligning the groove with the dowel pin.

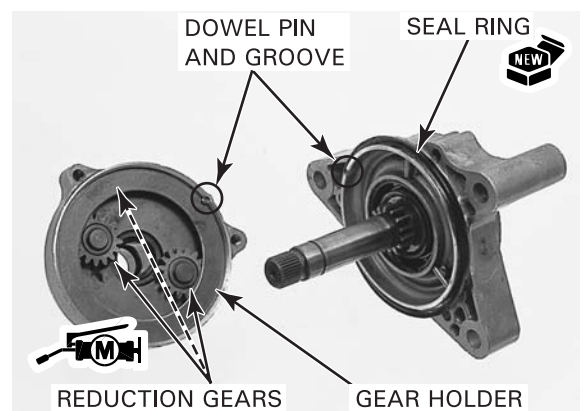

Install the three screws and tighten them securely.  
 Install the dowel pin and starter reduction gears, aligning the groove in the large outer gear with the pin.  
 Apply molybdenum disulfide grease to the starter reduction gears.

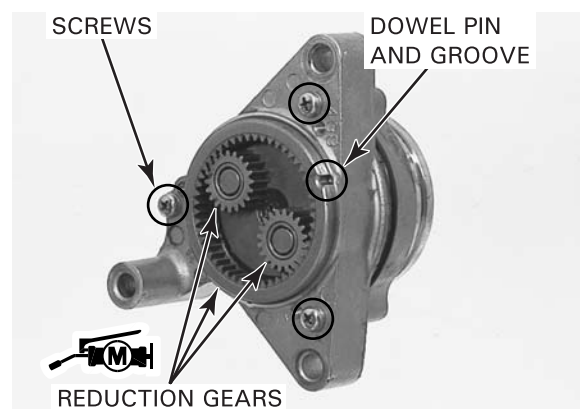



## STARTER/REVERSE SYSTEM

Install the washers and snap ring onto the starter shaft.

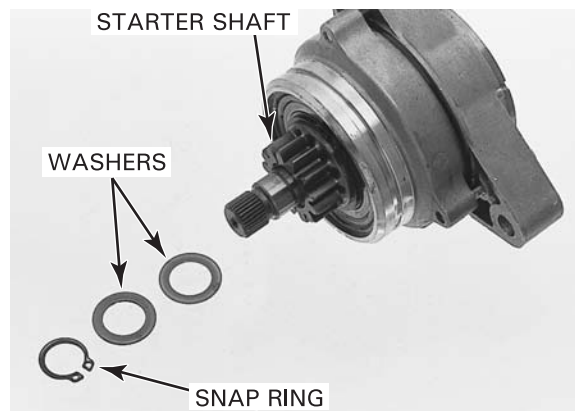

Install the following:

- insulator
- insulated brush
- cable terminal
- new O-ring
- insulator washers
- washer
- nut

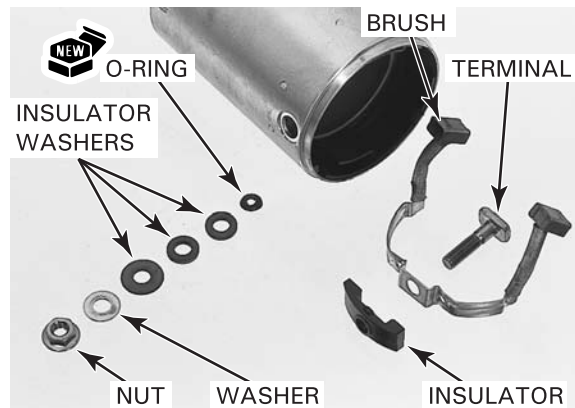

Install the brush holder, aligning the tab with the groove in the case, and wire grooves with the insulated brush wires.

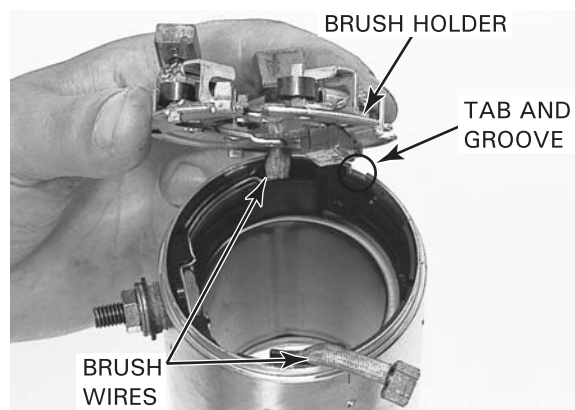

*The coil may be damaged if the magnet pulls the armature against the case.*

Push and hold the brushes inside the brush holder, and install the armature through the motor case and brush holder.

When installing the armature into the motor case, hold the armature tightly to prevent the magnet of the case from pulling the armature against it.

Install the washer and a new seal ring.

Install the rear cover, aligning the slot with the brush holder tab.

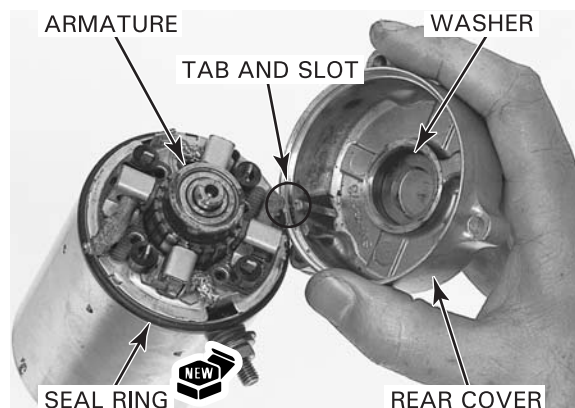



## STARTER/REVERSE SYSTEM

Install the washer.  
Install the gear base and gear base washer, aligning the grooves with the motor case lug.  
Install a new seal ring.  
Install the reduction gear case, aligning the groove in the large outer gear with the motor case lug.

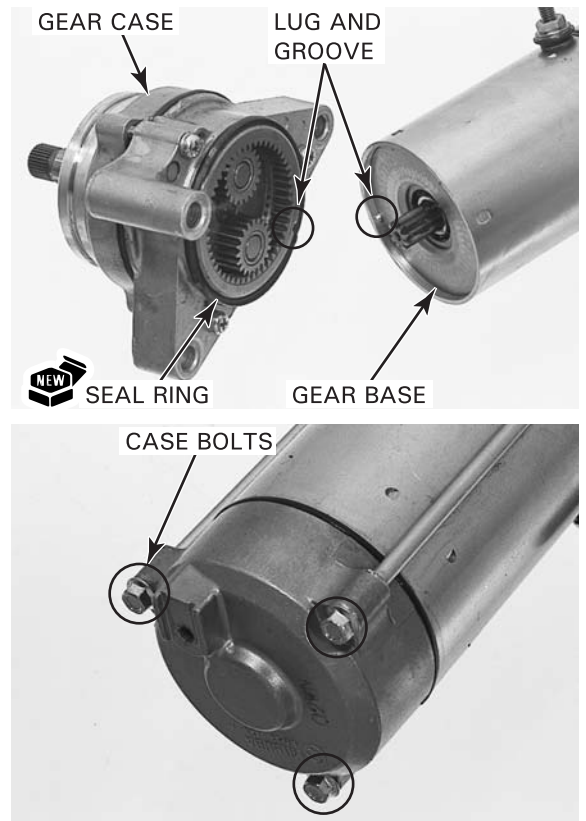

Install the three case bolts and tighten them securely.

### INSTALLATION

Coat a new O-ring with oil and install it into the starter/reverse motor groove.

Install the starter/reverse motor into the rear crankcase cover as shown.

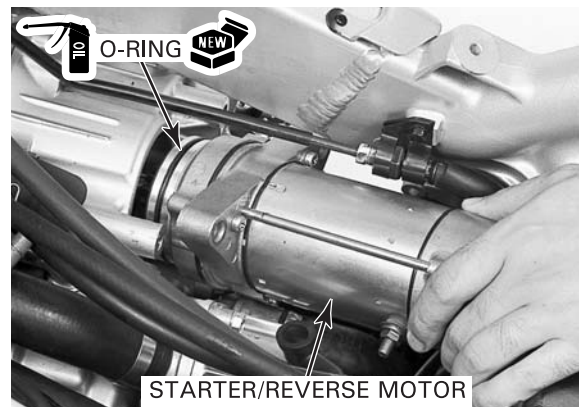

Install the three mounting bolts and tighten them.

**TORQUE: 29 N-m (3.0 kgf-m, 22 lbf-ft)**

Connect the starter motor cable.  
Install and tighten the terminal nut securely.  
Pull the rubber cap onto the terminal securely.

Install the following:

- reverse shift arm (page 19-49)
- fuel tank (page 5-56).

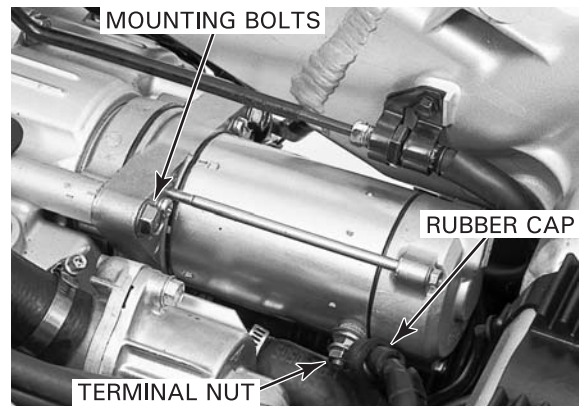

## STARTER/REVERSE SYSTEM

### STARTER RELAY SWITCH A

Make sure the engine stop switch is turned to "O" and the reverse shift switch is pushed to "OFF."  
Remove the left saddlebag (page 2-15).

#### INSPECTION

Shift the transmission into neutral.

Turn the ignition switch to "ON" and check that the neutral indicator comes on.

Push the starter/reverse switch.

The coil is normal if starter relay switch A clicks.

If you don't hear the switch "click," turn the ignition switch to "OFF," disconnect the 2P red connector of starter relay switch A and check the following:

#### RELAY COIL GROUND LINE

Turn the ignition switch to "ON."

Check for continuity between the Brown/red wire (ground line) terminal of the wire harness side connector and ground.

If there is continuity when the transmission is in neutral, or when the clutch is disengaged and the side stand is retracted, the ground line is normal. (There is a slight resistance due to the diode.)

#### RELAY COIL INPUT VOLTAGE LINE

Turn the ignition switch to "ON."

Measure the voltage between the Yellow/red wire terminal (+) of the wire harness side connector and ground (-).

If battery voltage is present only when the starter/reverse switch is pushed in, the input voltage line is normal.

#### OPERATION CHECK

Disconnect the battery and starter relay switch cables from starter relay switch A.

Connect a fully charged 12-V battery to the connector terminals of starter relay switch A.

#### CONNECTION:

**Battery (+) terminal – Yellow/red wire terminal**

**Battery (-) terminal – Green/red wire terminal**

There should be continuity between the cable terminals while the battery is connected, and no continuity when the battery is disconnected.

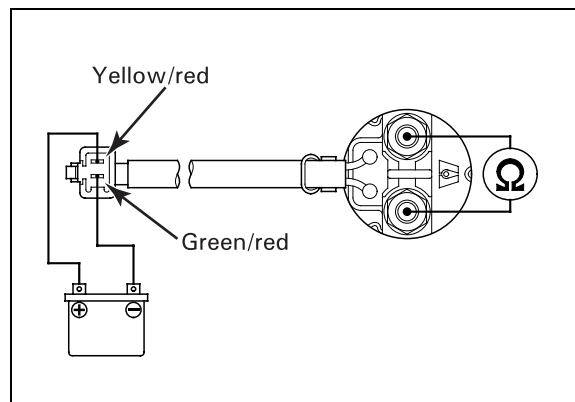
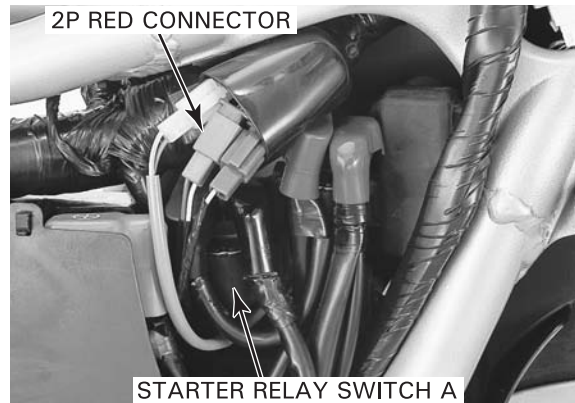

## STARTER RELAY SWITCH B

### NOTE:

- Check that starter relay switch A operates properly before inspecting starter relay switch B.

Make sure that the engine stop switch is turned to "OFF" and the reverse shift switch is pushed to "OFF."

Remove the left saddlebag (page 2-15).

### INSPECTION

Shift the transmission into neutral.

Turn the ignition switch to "ON" and push the starter/reverse switch.

The coil is normal if starter relay switch B clicks.

If you don't hear the switch "click," turn the ignition switch to "OFF," disconnect the 2P white connector of starter relay switch B and check the following:

#### RELAY COIL GROUND LINE

Check for continuity between the Green/red wire (ground line) terminal of the wire harness side connector and ground.

If there is continuity, the ground line is normal. (There is a slight resistance due to the diode.)

#### RELAY COIL INPUT VOLTAGE LINE

Turn the ignition switch to "ON."

Measure the voltage between the Yellow/red wire terminal (+) of the wire harness side connector and ground (-).

If battery voltage is present only when the starter/reverse switch is pushed in, the input voltage line is normal.

### OPERATION CHECK

Disconnect the starter relay switch and starter/reverse motor cables from starter relay switch B. Connect a fully charged 12-V battery to the connector terminals of starter relay switch B.

#### CONNECTION:

**Battery (+) terminal – Yellow/red wire terminal**

**Battery (-) terminal – Green/red wire terminal**

There should be continuity between the cable terminals while the battery is connected, and no continuity when the battery is disconnected.

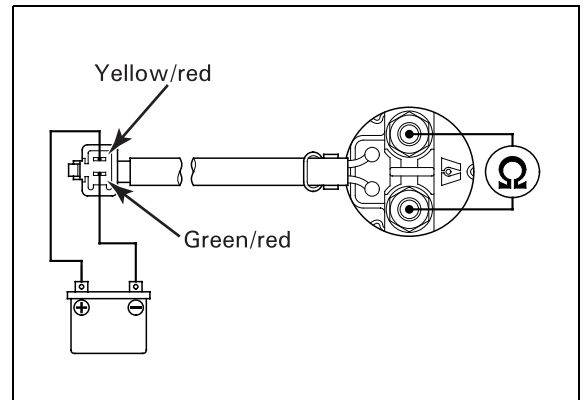
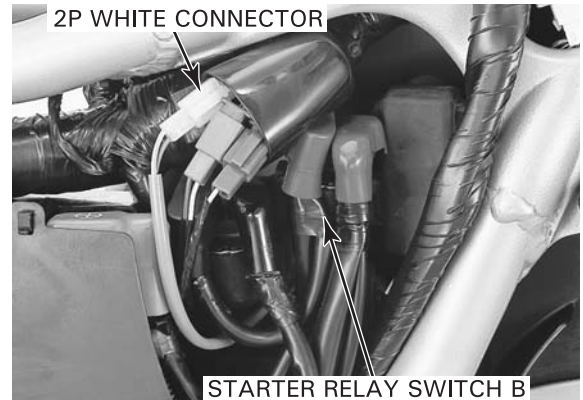

## STARTER/REVERSE SYSTEM

### REVERSE RELAY

#### SYSTEM INSPECTION

Make sure that the engine stop switch is turned to "OFF" and the reverse shift switch is pushed to "OFF."

Check that the neutral indicator operates properly (page 20-26).

Remove the seat (page 2-5).

Remove the two screws and remove the relay box.  
Remove the relay blocks from the relay box.



1. Turn the ignition switch to "OFF" and exchange the reverse relay with the other good one.  
Turn the ignition switch to "ON."  
Push the starter/reverse switch and check starter relay switch A.

- If starter relay switch A clicks, replace the reverse relay with a new one.
- If starter relay switch A does not click, GO TO STEP 2.



2. Turn the ignition switch to "OFF" and remove the reverse relay.

Turn ignition switch to "ON."

Measure the voltage between the Yellow/red wire terminal (+) of the relay connector and ground (-).

There should be battery voltage.

- If there is battery voltage, GO TO STEP 3.
- If there is no voltage, check the following:
  - open circuit in the Yellow/red and Black/red wires between the reverse relay and reverse shift switch
  - loose or poor contact of the related connector
  - faulty diode (D7) in the reverse regulator assembly (page 19-28)

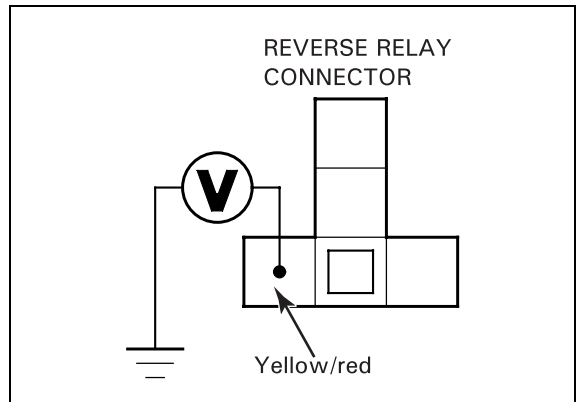

3. Turn the ignition switch to "OFF."  
Check for continuity between the Black/red wire terminal of the relay connector and ground.  
There should be continuity.

- If there is continuity, GO TO STEP 4.
- If there is no continuity, check the following:
  - open circuit in the Black/red wire between the reverse relay and reverse regulator assembly
  - faulty diode (D4 or D5) in the reverse regulator assembly (page 19-28)
  - open circuit in the Green/orange wire between the reverse regulator assembly and reverse switch
  - faulty reverse switch

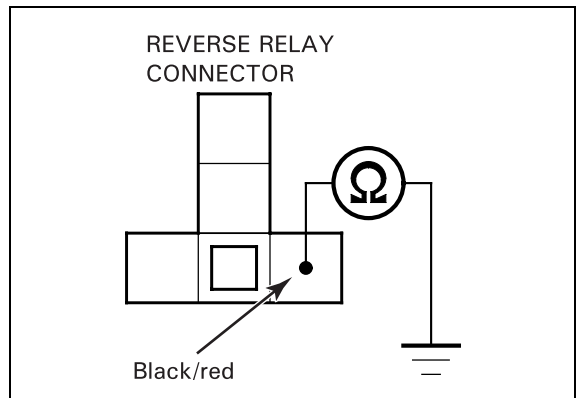

4. Check for continuity between the Blue/green wire terminal of the relay connector and ground. There should be continuity when the transmission is in neutral, or when the clutch is disengaged and the side stand is retracted.
  - If there is continuity, the system is OK; check for loose contacts or corroded terminals.
  - If there is no continuity, check the following:
    - open circuit in the Blue/green wire between the reverse relay and reverse regulator assembly
    - faulty diode (D2, D3 or D11) in the reverse regulator assembly (page 19-28)
    - open circuit in the Green/red wire between the reverse regulator assembly and clutch switch
    - faulty clutch switch
    - open circuit in the Green/white between the clutch switch and side stand switch
    - faulty side stand switch

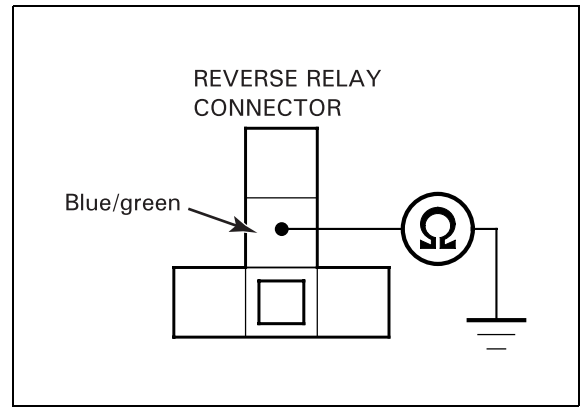

## REVERSE SWITCH

### REMOVAL/INSTALLATION

Remove the right engine side cover (page 2-5).

Pull the rubber cap off the reverse switch.  
Remove the terminal nut and reverse switch wire.  
Remove the reverse switch from the crankcase.

Install the reverse switch with a new sealing washer and tighten it.

**TORQUE: 12 N·m (1.2 kgf·m, 9 lbf·ft)**

Install the switch wire and tighten the terminal nut.

**TORQUE: 2 N·m (0.2 kgf·m, 1.4 lbf·ft)**

Install the rubber cap on the reverse switch.

Install the right engine side cover (page 2-5).

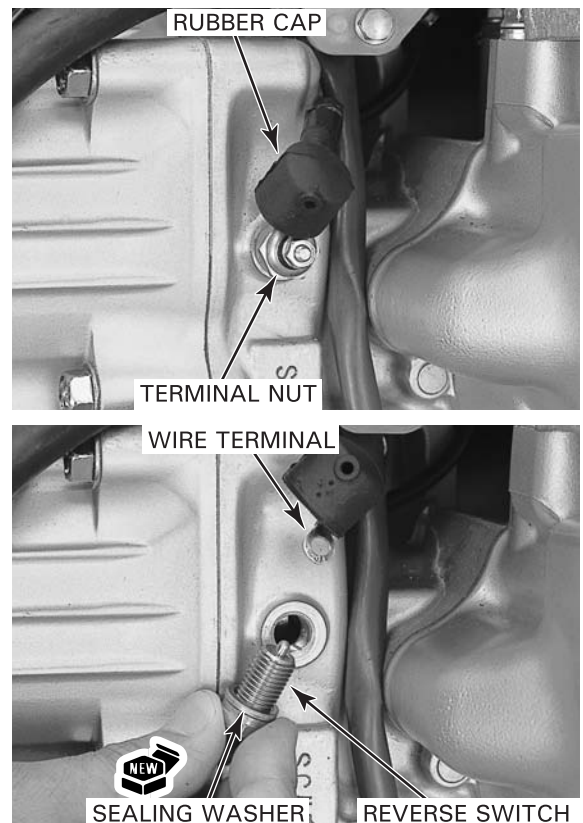



## STARTER/REVERSE SYSTEM

### INSPECTION

Check that the switch shaft moves smoothly by pushing it.

Check for continuity between the switch terminal and shaft.

There should be continuity.

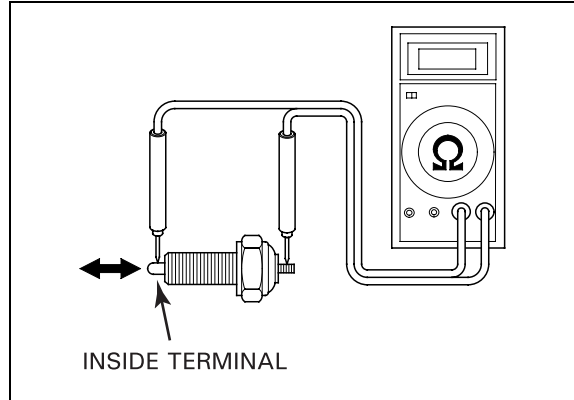

## REVERSE REGULATOR ASSEMBLY

### REMOVAL/INSTALLATION

Remove the left saddlebag (page 2-15).

Remove the reverse regulator assembly from rear fender B.

Disconnect the 20P connector and remove the reverse regulator assembly.

Install the reverse regulator assembly in the reverse order of removal.

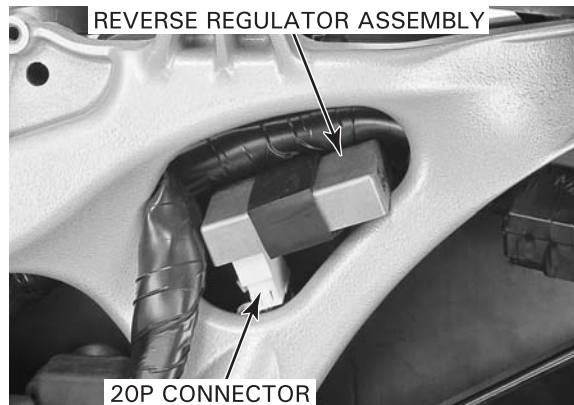

### DIODE INSPECTION

Remove the reverse regulator assembly (page 19-28).

#### NOTE:

- The 11 diodes are integrated in the assembly. They are used in the following circuits:

- D1: Ground of starter relay switch B coil  
Ground of reverse relay (neutral position side)  
Gear position (neutral) signal of engine control module (ECM)
- D2: Ground of reverse relay (clutch switch and side stand switch side)
- D3: Ground of reverse relay coil (reverse switch side)
- D4: Ground of reverse relay coil (neutral position side)
- D5: Ground of neutral indicator
- D6: Power source of reverse relay coil  
Power source of headlight and headlight relay in reverse running
- D7: Gear position (overdrive) signal of ECM
- D8: Gear position (4th) signal of ECM
- D9: Ground of reverse relay
- D10: Ground of reverse relay
- D11: Ground of reverse relay



Check the continuity for each diode between the following terminals:

Diode	D1	D2	D3	D4	D5	D6
Terminal (+)	12	18	18	1	1	14
Terminal (-)	11	13	16	11	13	13

Diode	D7	D8	D9	D10	D11
Terminal (+)	2	4	7	8	15
Terminal (-)	3	5	17	6	18

When there is continuity, a small resistance value will register.

If there is continuity in one direction, the diode is good.

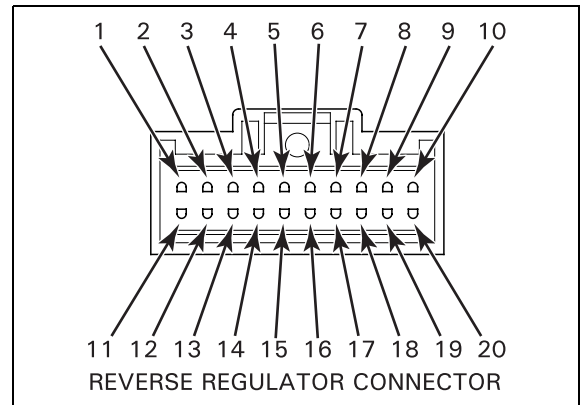

### REGULATED VOLTAGE INSPECTION

Remove the left saddlebag (page 2-15).

Shift the transmission into neutral and retract the side stand.

Raise the rear wheel off the ground by placing the motorcycle on its center stand.

Start the engine, push the reverse shift switch to "ON" and make sure that the reverse indicator comes on.

Measure the voltage at the starter relay switch A 2P red connector with the connector connected.

#### CONNECTION:

**Brown/red wire terminal (+) — Ground (-)**

*The rear wheel starts turning if the reverse system functions properly.*

Push the starter/reverse switch.

The voltage should be approximately 0 V for the first 0.3 second, then a minimum of 4.0 V should register.

Push the reverse shift switch to "OFF" and stop the engine.

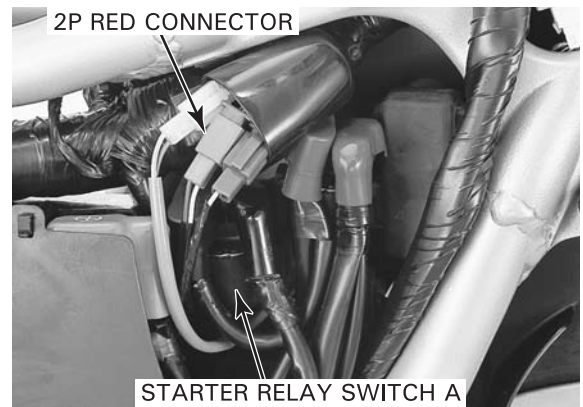

### REVERSE REGULATOR CIRCUIT INSPECTION

Remove the reverse regulator assembly (page 19-28).

Check the following at the wire harness side connector of the reverse regulator assembly:

#### GROUND LINE

Check for continuity between the Green wire terminal and ground.

There should be continuity at all times.

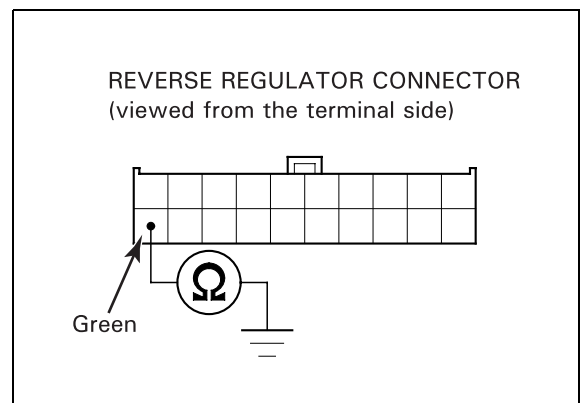

## STARTER/REVERSE SYSTEM

### REVERSE POSITION SWITCH LINE

Connect the reverse regulator 20P connector.  
Shift the transmission into neutral and turn the ignition switch to "ON."  
Push the reverse shift switch to "ON" and check that the reverse indicator comes on.  
Turn the ignition switch to "OFF" and disconnect the reverse regulator 20P connector.  
Turn the ignition switch to "ON."  
Measure the voltage between the White/blue wire terminal (+) of the wire harness side 20P connector and ground (-).  
There should be battery voltage.

After inspection, turn the reverse shift actuator to the neutral position.

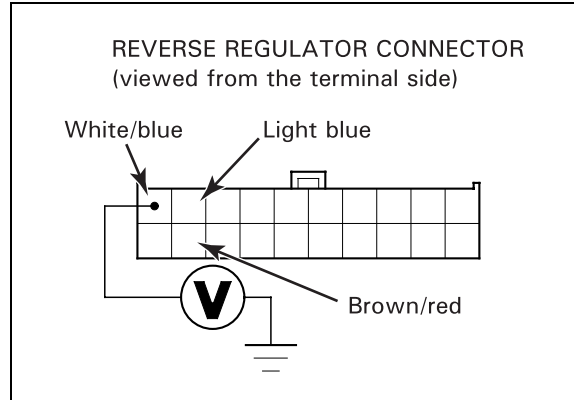

### STARTER RELAY SWITCH LINE

Turn the ignition switch to "OFF."  
Disconnect the 2P red connector of starter relay switch A.  
Check for continuity between the Brown/red wire terminals of the reverse regulator and starter relay switch A connectors.  
There should be continuity.

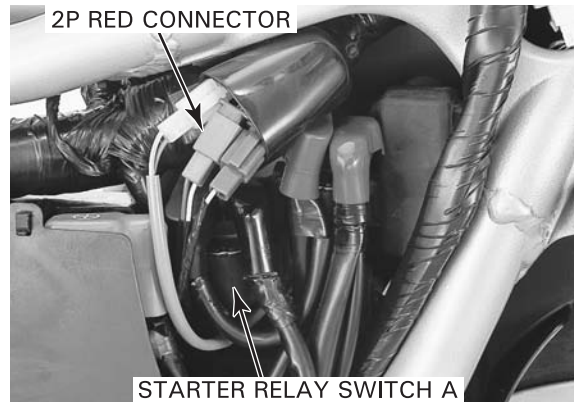

### CONTROL MODULE LINE

Remove the top shelter (page 2-11)  
Turn the ignition switch to "OFF."  
Disconnect cruise/reverse control module 26P gray connector.  
Check for continuity between the Light blue wire terminals of the reverse regulator and control module connectors.  
There should be continuity.



## REVERSE RESISTOR ASSEMBLY

### REMOVAL/INSTALLATION

Remove the battery case (page 5-56).  
Disconnect the reverse resistor 3P connector.  
Remove the nut and cable from the reverse resistor terminal.  
Remove the two bolts and reverse resistor assembly.

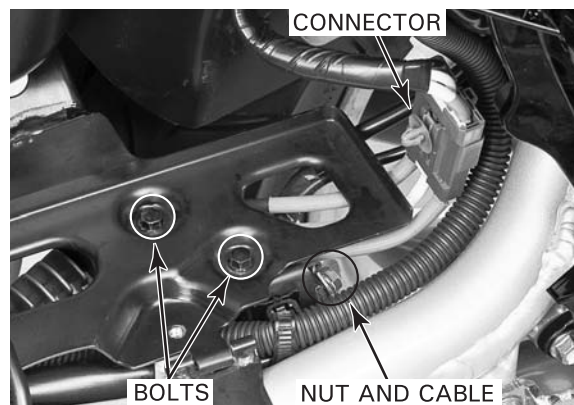

Remove the three screws and stay from the reverse resistor assembly.

Install the reverse resistor assembly in the reverse order or removal.

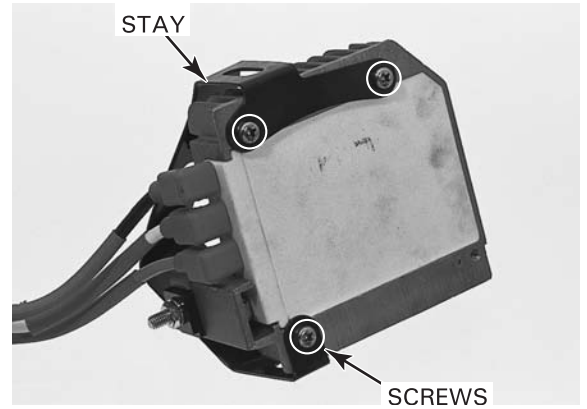

### INSPECTION

Measure the resistance between the 3P connector wire terminals and cable terminal of the resistor.

**STANDARDS at 20° C (68° F)**

**Red – Cable terminal: 0.20 – 0.25Ω**

**White – Cable terminal: 0.15 – 0.20Ω**

**Black – Cable terminal: 0.20 – 0.25Ω**

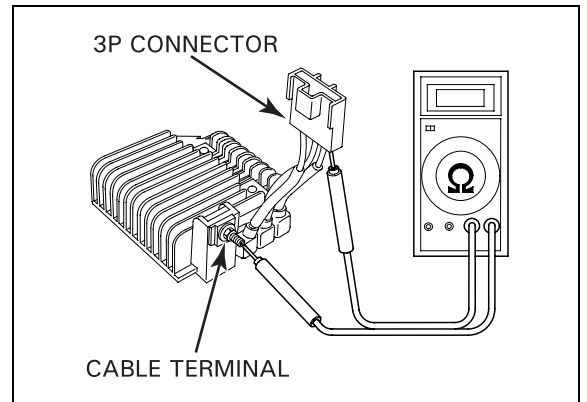

## POWER CONTROL RELAY

### SYSTEM INSPECTION

Remove the following:

- top shelter (page 2-11)
- left saddlebag (page 2-15)

Shift the transmission into neutral and turn the ignition switch to "ON."

Push the reverse shift switch to "ON" and check that the reverse indicator comes on.

Turn the ignition switch to "OFF" and disconnect the cruise/reverse control module 26P gray connector.



### POWER CONTROL RELAY 1

1. Ground the Orange wire terminal of the control module connector with a jumper wire. Turn the ignition switch to "ON" and check that power control relay 1 clicks.

- If the relay clicks, the relay coil is normal; go to step 3.
- If the relay does not click, go to step 2.

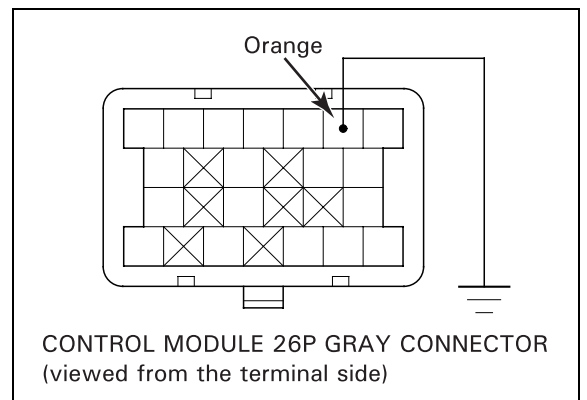

## STARTER/REVERSE SYSTEM

2. Turn the ignition switch to "OFF."

*Power control relay 1 is the same part as power control relay 2 and the speed limiter relay.*

Exchange power control relay 1 with the other good one and check again.

- If the relay clicks, replace power control relay 1 with a new one and go to step 3.
- If the relay does not click, check the following:
  - open circuit in the Orange wire between power control relay 1 and cruise/reverse control module
  - open circuit in the White/blue wire between power control relay 1 and reverse shift actuator (reverse position switch)

3. Turn the ignition switch to "OFF" and disconnect the reverse resistor connector.

With the jumper wire ground, turn the ignition switch to "ON."

Check for continuity between the Red and Black wire terminals of the wire harness side reverse resistor connector.

There should be continuity.

- If there is no continuity, check for open circuit in Red and Black wires between power control relay 1 and reverse resistor.

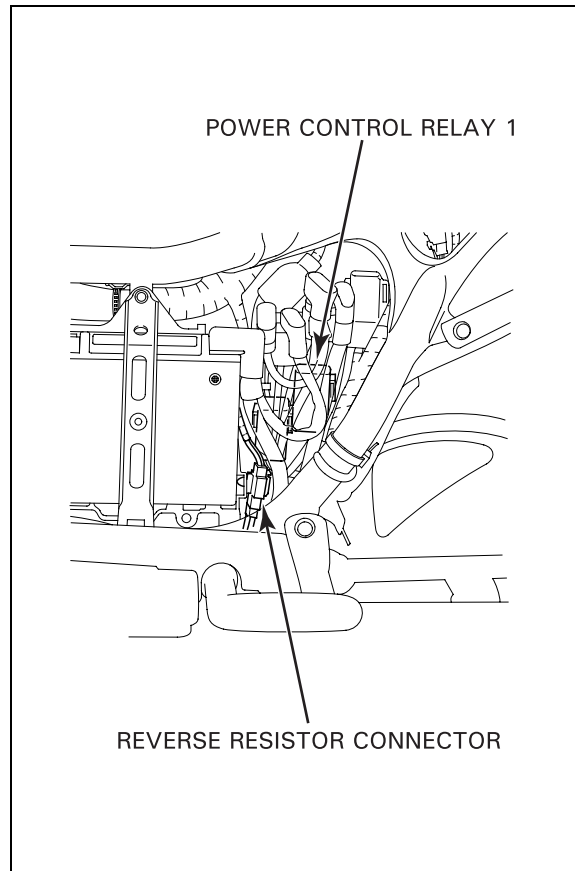

### POWER CONTROL RELAY 2

1. Ground the White wire terminal of the control module connector with a jumper wire. Turn the ignition switch to "ON" and check that power control relay 2 clicks.

- If the relay clicks, the relay coil is normal; go to step 3.
- If the relay does not click, go to step 2.

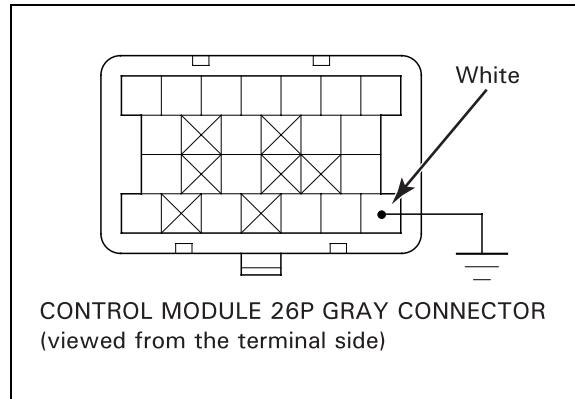

2. Turn the ignition switch to "OFF."

*Power control relay 2 is the same part as power control relay 1 and the speed limiter relay.*

Exchange power control relay 2 with a known-good one and check again.

- If the relay clicks, replace power control relay 2 with a new one and go to step 3.
- If the relay does not click, check the following:
  - open circuit in the White wire between power control relay 2 and the cruise/reverse control module
  - open circuit in the White/blue wire between power control relay 2 and reverse shift actuator (reverse position switch)

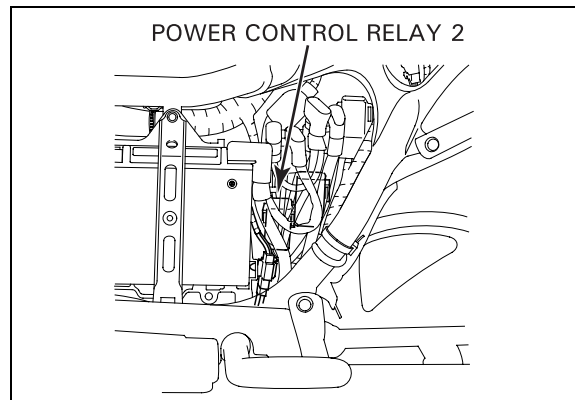

3. Turn the ignition switch to "OFF" and disconnect the reverse resistor connector.  
With the jumper wire ground, turn the ignition switch to "ON."  
Check for continuity between the Red and White wire terminals of the wire harness side reverse resistor connector.  
There should be continuity.
  - If there is no continuity, check for an open circuit in the Red and White wires between power control relay 2 and the reverse resistor.

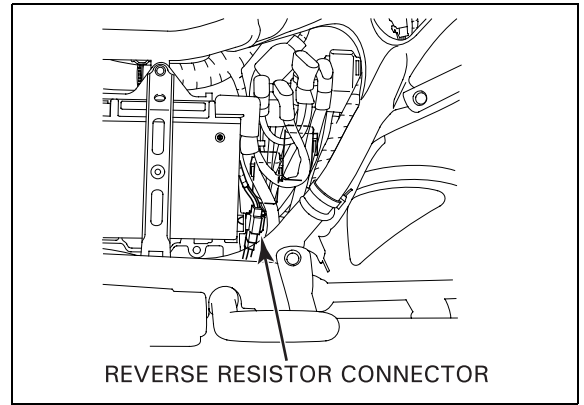

### OPERATION CHECK

Remove the power control relay.  
Connect an ohmmeter and a fully charged 12-V battery to the relay terminals as shown.

There should be continuity while the battery is connected, and no continuity when the battery is disconnected.

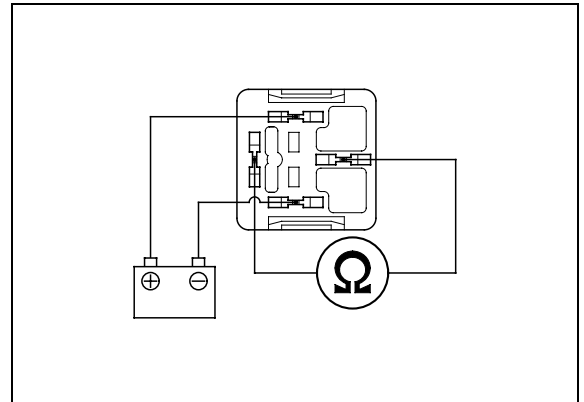

## SPEED LIMITER RELAY

### SYSTEM INSPECTION

- Remove the following:
- top shelter (page 2-11)
  - left saddlebag (page 2-15)

Shift the transmission into neutral and turn the ignition switch to "ON."  
Push the reverse shift switch to "ON" and check that the reverse indicator comes on.  
Turn the ignition switch to "OFF" and disconnect the cruise/reverse control module 26P gray connector.



1. Ground the Gray wire terminal of the control module connector with a jumper wire.  
Turn the ignition switch to "ON" and check that the speed limiter relay clicks.
  - If the relay clicks, the relay coil is normal; go to step 3.
  - If the relay does not click, go to step 2.

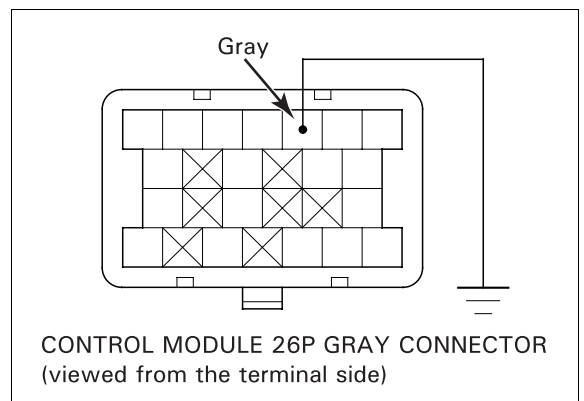



## STARTER/REVERSE SYSTEM

*The speed limiter relay is the same part as power control relays 1 and 2.*

2. Turn the ignition switch to "OFF."

Exchange the speed limiter relay with a known-good one and check again.

- If the relay clicks, replace the speed limiter relay with a new one and go to step 3.
- If the relay does not click, check the following:
  - open circuit in the Gray wire between the speed limiter relay and cruise/reverse control module.
  - open circuit in the White/blue wire between the speed limiter relay and reverse shift actuator (reverse position switch)

3. Turn the ignition switch to "OFF" and disconnect the reverse resistor connector.

Check for continuity between the White wire terminals of the speed limiter relay and reverse resistor connectors.

There should be continuity.

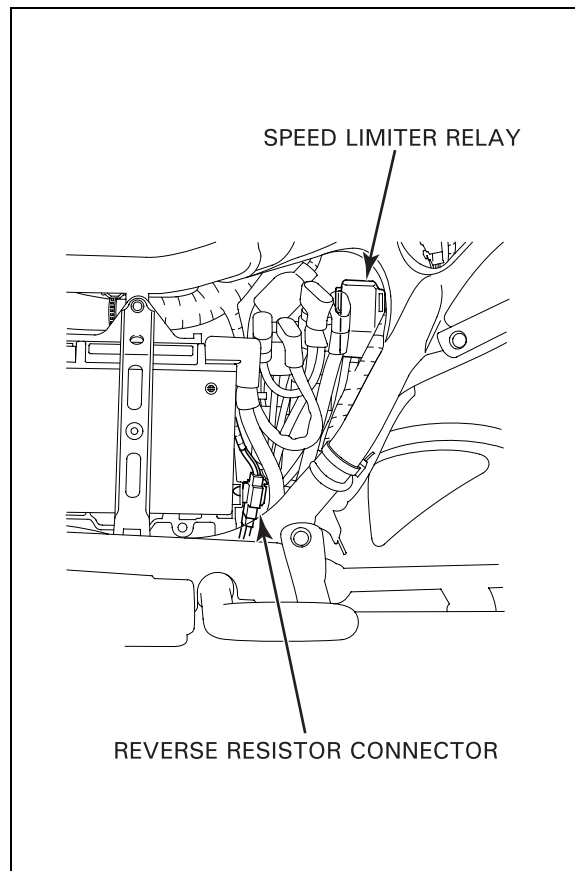

### OPERATION CHECK

Remove the speed limiter relay.

Connect an ohmmeter and a fully charged 12-V battery to the relay terminals as shown.

There should be continuity while the battery is connected, and no continuity when the battery is disconnected.

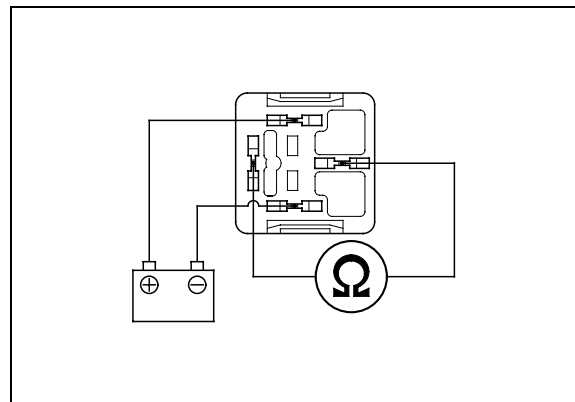

## REVERSE SHIFT RELAY

Check that the neutral indicator comes on when the ignition switch is turned to "ON" with the transmission in neutral.

Remove the seat (page 2-5).

Remove the two screws and remove the relay box. Remove the relay blocks from the relay box.

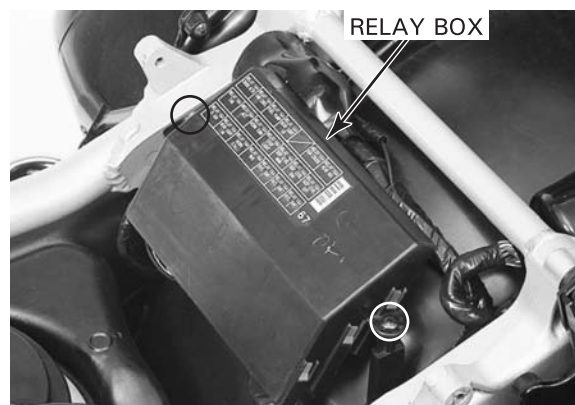



## STARTER/REVERSE SYSTEM

1. Turn the ignition switch to "OFF" and exchange reverse shift relay 1 with a known-good one. Shift the transmission into neutral and turn the ignition switch to "ON."  
Turn the reverse shift switch to "ON."
  - If the reverse shift actuator operates, replace reverse shift relay 1 with a new one.
  - If the reverse shift actuator does not operate, go to step 2.
2. Push the reverse shift switch to "OFF," turn the ignition switch to "OFF," and exchange reverse shift relay 2 with a known-good one. Turn the ignition switch to "ON" and push the reverse shift switch to "ON."
  - If the reverse shift actuator operates, replace reverse shift relay 2 with a new one and check again using original reverse shift relay 1.
  - If the reverse shift actuator does not operate, go to step 3.
3. Push the reverse shift switch to "OFF," turn the ignition switch to "OFF," and exchange reverse shift relay 3 with a known-good one. Turn the ignition switch to "ON" and push the reverse shift switch to "ON."
  - If the reverse shift actuator operates, replace reverse shift relay 3 with a new one and check again using original reverse shift relays 1 and 2.
  - If the reverse shift actuator does not operate, go to step 4.
4. Turn the ignition switch to "OFF" and remove reverse shift relay 1. Measure the voltage between the Red/black wire terminal (+) of the relay connector and ground (-).
  - If there is battery voltage, go to step 5.
  - If there is no voltage, check for an open circuit in the Red/black wire between the relay box and fuse box (No. 23 fuse).
5. Turn the ignition switch to "ON."  
Measure the voltage between the Brown wire terminal (+) of the relay connector and ground (-).
  - If there is battery voltage, go to step 6.
  - If there is no voltage, check for an open circuit in the Brown wire between the relay box and fuse box (No. 10 fuse).
6. Check the Red wires for continuity between relays 1 and 2, and between relays 1 and 3.
  - If there is continuity, follow the troubleshooting flow chart on page 19-9.
  - If there is no continuity, repair the open circuit in the Red wire.

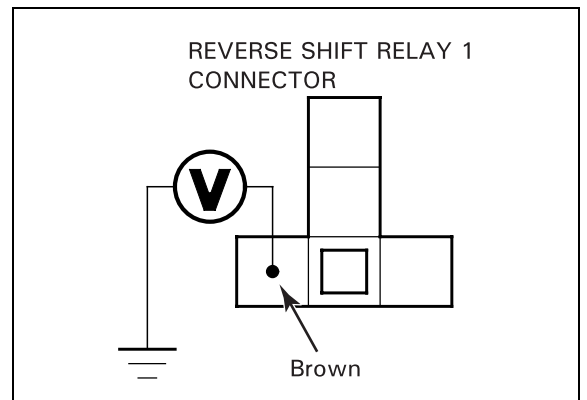
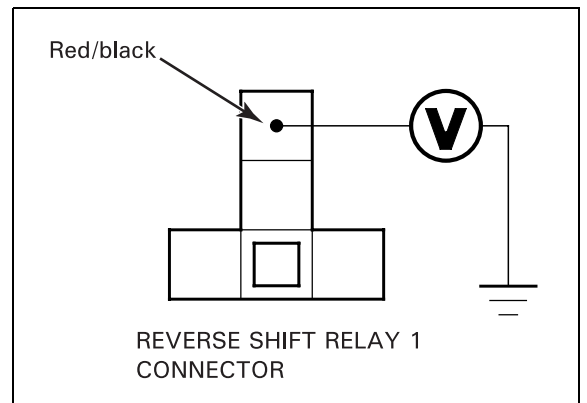
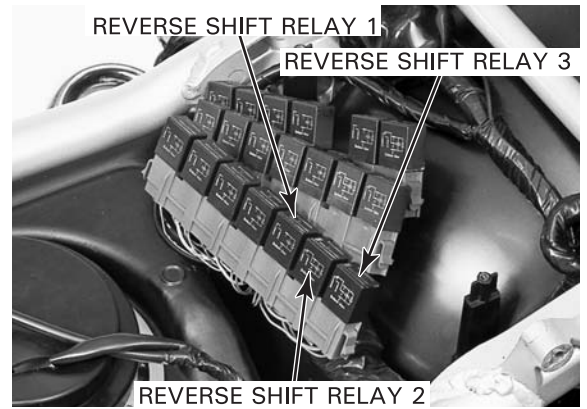

# REVERSE SHIFT ACTUATOR

### MOTOR INSPECTION

1. Turn the ignition switch to "OFF" and remove the reverse shift relays 2 and 3 (page 19-34).
2. Shift the transmission into neutral.  
Connect a fully charged 12-V battery to the relay connector terminals.

**CONNECTION: Positive (+) – Blue of relay 2**  
**Negative (-) – Blue/red of relay 3**

- If the reverse shift actuator operates, the motor is normal.
- If the actuator does not operate, go to step 3.

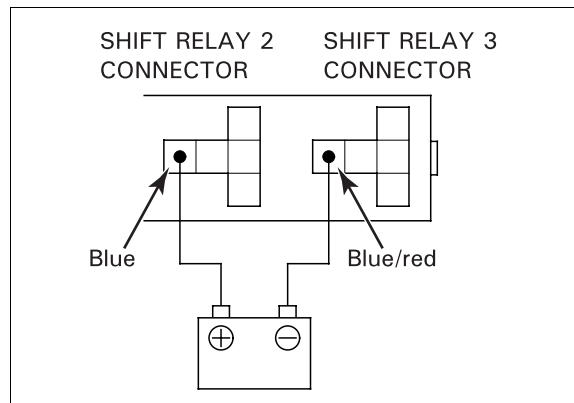

3. Remove the air cleaner housing (page 5-57).  
Disconnect the reverse shift actuator 2P white connectors.  
Connect a fully charged 12-V battery to the actuator side connector terminals.

**CONNECTION: Positive (+) – Blue**  
**Negative (-) – Blue/red**

- If the actuator operates, check the following:
    - open circuit in the Blue wire between reverse shift relay 2 and the actuator
    - open circuit in the Blue/red wire between reverse shift relay 3 and the actuator
  - If the actuator does not operate, go to step 4.
4. Disconnect the reverse shift actuator cables from the actuator (page 19-38) and check again.
    - If the actuator operates, check the reverse shift mechanism (page 19-42).
    - If the actuator does not operate, replace the actuator with a new one.



### REVERSE POSITION SWITCH INSPECTION

- Remove the air cleaner housing (page 5-57).  
Disconnect the reverse shift actuator 3P red and 2P white connectors.

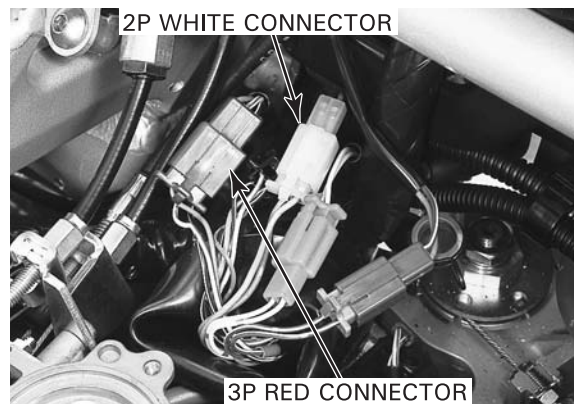

## INPUT VOLTAGE CHECK

Temporarily install the battery.  
Turn the ignition to "ON" and measure the voltage between the Brown wire terminal (+) of the wire harness side 3P connector and ground (-).  
There should be battery voltage.

- If there is no voltage, check for an open circuit in the Brown wire between the reverse shift actuator and fuse box (No. 10 fuse).

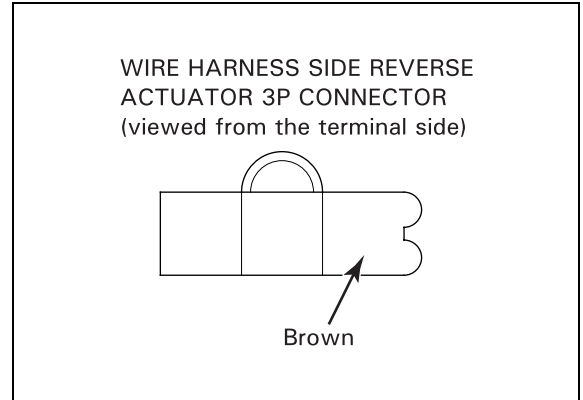

## OPERATION CHECK

Make sure the reverse shift actuator is in the neutral position.  
Check for continuity between the Brown and Black/white wire terminals of the actuator side 3P connector.  
There should be continuity.

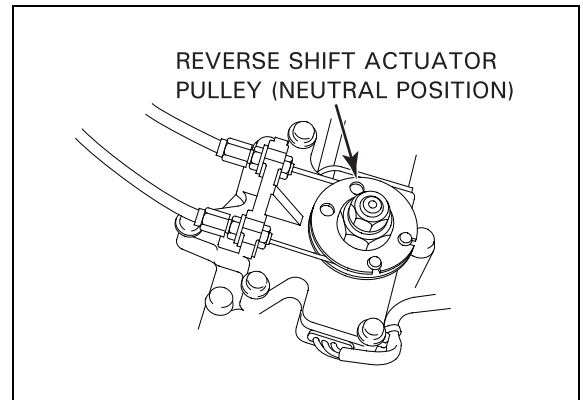

Turn the actuator to the reverse position by connecting a fully charged 12-V battery to the actuator side 2P connector terminals.

**CONNECTION: Positive (+) – Blue**  
**Negative (-) – Blue/red**

Check for continuity between the Brown and White/blue wire terminals of the actuator side 3P connector.  
There should be continuity.

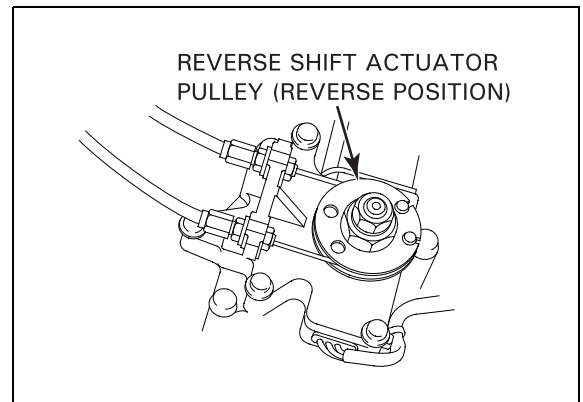

## REMOVAL/INSTALLATION

Remove the following:

- right engine side cover (page 2-5)
- ABS modulators (page 16-31)

Loosen the lock nuts and adjusting nuts on the reverse shift actuator cables fully.

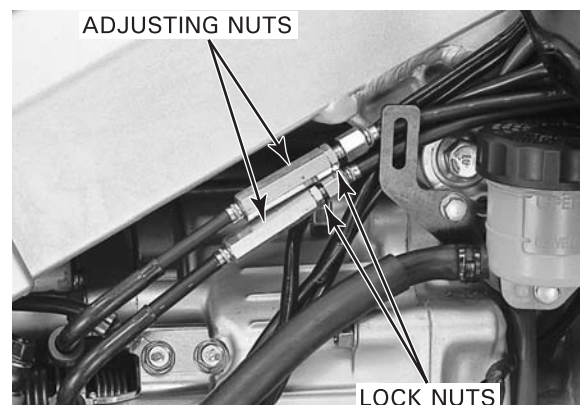

## STARTER/REVERSE SYSTEM

Remove the nuts and reverse shift actuator cables from the cable holder, and disconnect the cables from the actuator pulley.  
Remove the three bolts and the reverse shift actuator from the crankcase.

Install the reverse shift actuator onto the crankcase and tighten the three bolts securely.  
Connect the R (reverse) cable to the pulley on the "R" mark side and N (neutral) cable on the "N" mark side.

Install and tighten the lock nuts.

Adjust the actuator cables.

Install the following:

- ABS modulators (page 16-31)
- right engine side cover (page 2-5)

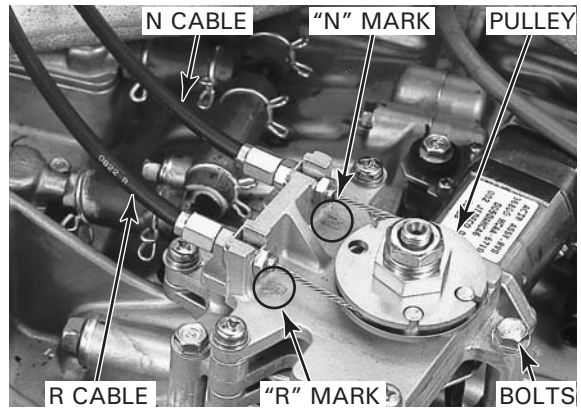

### REVERSE SHIFT ACTUATOR CABLE ADJUSTMENT

Remove the following:

- right engine side cover (page 2-5)
- center inner fairing (page 2-10)

Check that the reverse shift actuator pulley is in the neutral position as shown.

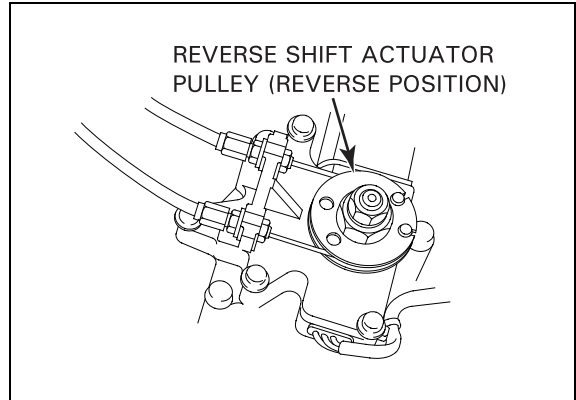

Check the N cable clearance between the cable outer end and cable holder.

**CLEARANCE: 0 mm (0 in)**

Check the R cable clearance between the cable outer end and cable holder.

**CLEARANCE: 0.3 – 0.8 mm (0.01 – 0.03 in)**

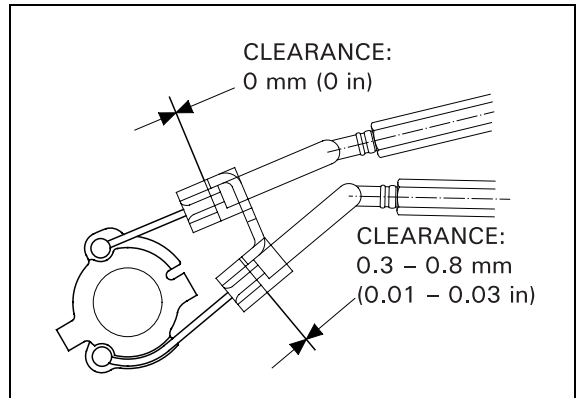

Loosen each lock nut and adjust the clearance by turning each adjusting nut as required.

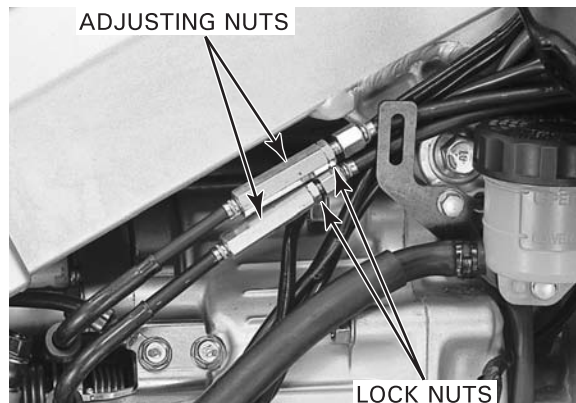

## STARTER/REVERSE SYSTEM

Shift the transmission into neutral and turn the ignition switch to "ON."  
Push the reverse shift switch to "ON" to move the reverse actuator pulley to the reverse position.

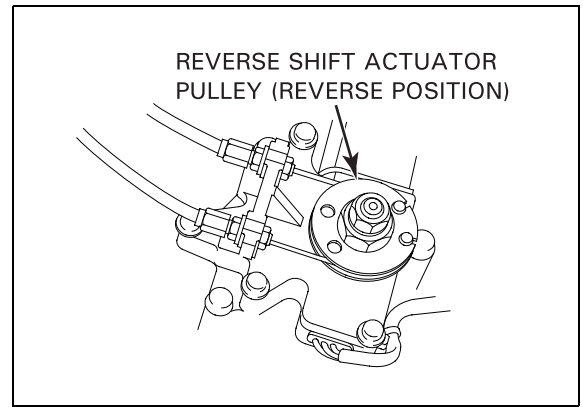

Make sure there is clearance between the reverse shift arm and lost motion plate as shown.

Push the reverse shift switch to "OFF" to return the reverse actuator pulley to the neutral position.

Turn the ignition switch to "OFF" and install the following:

- center inner fairing (page 2-6)
- right engine side cover (page 2-5)

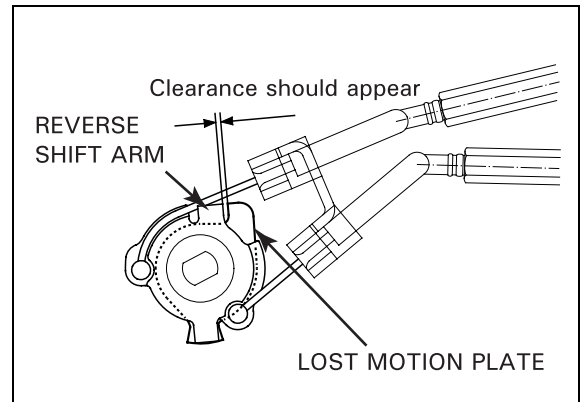

## CRUISE/REVERSE CONTROL MODULE

### SYSTEM INSPECTION

Remove the top shelter (page 2-11).

Turn the ignition switch to "OFF" and disconnect the 26P black and gray connectors from the cruise/reverse control module.



Check the reverse system circuits at the wire harness side connector terminals by referring to the chart on page 19-40.

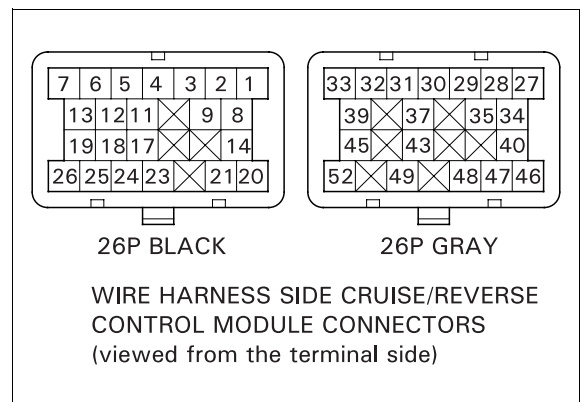

## STARTER/REVERSE SYSTEM

**NOTE:**

- To turn the reverse shift actuator from the neutral position to the reverse position, follow the steps below:
  - Turn the ignition switch to “OFF,” and connect the control module connectors.
  - Shift the transmission into neutral and turn the ignition switch to “ON.”
  - Push the reverse shift switch to “ON.”  
The reverse position switch turns to the reverse position and reverse indicator comes on.
  - Turn the ignition switch to “OFF” and disconnect the control module connectors.
- To move the reverse shift actuator from the reverse position to the neutral position, follow the steps below:
  - Turn the ignition switch to “OFF,” and connect the control module connectors.
  - Turn the ignition switch to “ON.”
  - Turn the reverse shift switch to “OFF.”  
The reverse position switch turns to the neutral position and neutral indicator comes on.
  - Turn the ignition switch to “OFF” and disconnect the control module connectors.

Terminal No. & Circuit		Wire Color & Connection	Conditions	Specification			
1	Reverse shift motor (+)	Pink and Pink of the control module and reverse shift relays 2, 3 connectors	Remove reverse shift relays 2 and 3 (page 19-34) and check for continuity between the same color wire terminals.	There should be continuity.			
8	Reverse shift motor (-)	Green and ground	-	There should be continuity.			
11	Side stand switch	Green/white and ground	Side stand retracted	There should be continuity.			
			Side stand extended	There should be no continuity.			
12	Starter/reverse motor	Pink/white and starter/reverse motor cable terminal of starter relay switch B	Remove the left saddlebag (page 2-15).	There should be continuity.			
17	Reverse switch	Green/orange and ground	Reverse shift actuator in the neutral position	There should be continuity.			
			Reverse shift actuator in the reverse position	There should be no continuity.			
18	Starter/reverse switch	Yellow/red (+) and ground (-)	Ignition switch “ON” Engine stop switch to “  27	Reverse shift relay 3	Yellow/white and Yellow/white of the control module and reverse shift relay 3	Remove reverse shift relay 3 (page 19-34) and check for continuity between the same color wire terminals.	There should be continuity.
Yellow/white and ground	-	There should be no continuity.					
28	Power control relay 1	Orange (+) and ground (-)	Reverse shift actuator in the reverse position Ignition switch “ON”	There should be battery voltage.			
29	Speed limiter relay	Gray (+) and ground (-)	Reverse shift actuator in the reverse position Ignition switch “ON”	There should be battery voltage.			



## STARTER/REVERSE SYSTEM

Terminal No. & Circuit		Wire Color & Connection	Conditions	Specification
34	Reverse shift relay 2	Blue/white and Blue/white of the control module and reverse shift relay 2	Remove reverse shift relay 2 (page 19-34) and check for continuity between the same color wire terminals.	There should be continuity.
		Blue/white and ground	-	There should be no continuity.
37	Reverse regulator	Light blue and Light blue of the control module and reverse regulator	Remove the reverse regulator (page 19-28) and check for continuity between the same color wire terminals.	There should be continuity.
40	Reverse shift relay 1	Blue/black (+) and ground (-)	Ignition switch "ON"	There should be battery voltage.
43	Reverse relay	Yellow/red (+) and ground (-)	Ignition switch "ON"	There should be battery voltage.
46	Power control relay 2	White (+) and ground (-)	Reverse shift actuator in the reverse position Ignition switch "ON"	There should be battery voltage.
47	Neutral switch	Light green/red and ground	Transmission in neutral	There should be continuity.
48	Oil pressure switch	Blue and ground	-	There should be continuity.
			Start the engine and let it idle.	There should be no continuity.
52	Ground	Green and ground	-	There should be continuity.

## STARTER/REVERSE SYSTEM

### REVERSE SHIFT MECHANISM

#### REVERSE SHIFT ARM REMOVAL

Remove the rear brake master cylinder (page 15-19).

Remove the two bolts, ground cable and reverse shift actuator cable holder.

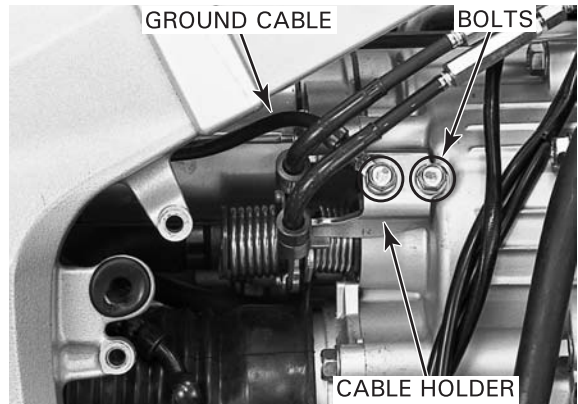

Remove the following:

- bolt
- washer
- collar
- lost motion spring
- reverse shift arm with the cables and holder

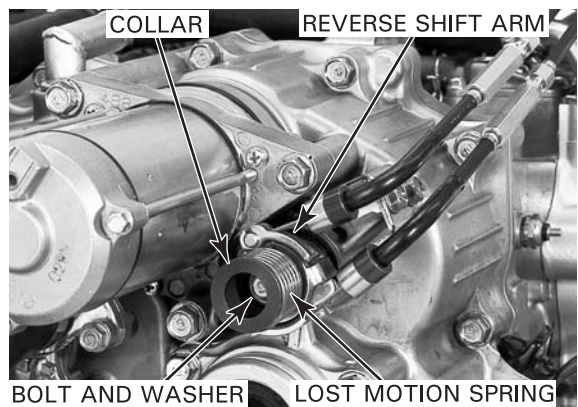

- lost motion plate
- reverse shift arm spring
- bushing
- spring collar
- O-ring from the collar

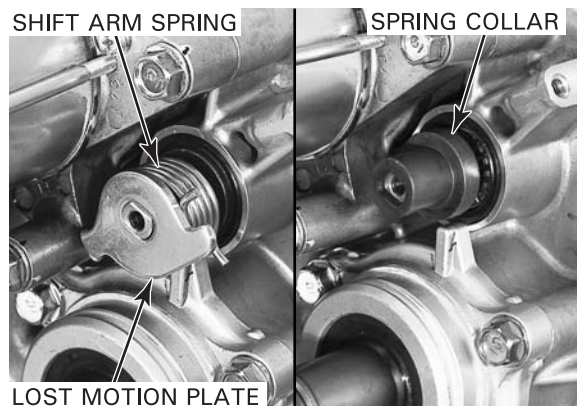

- needle bearing
- washer
- oil seal

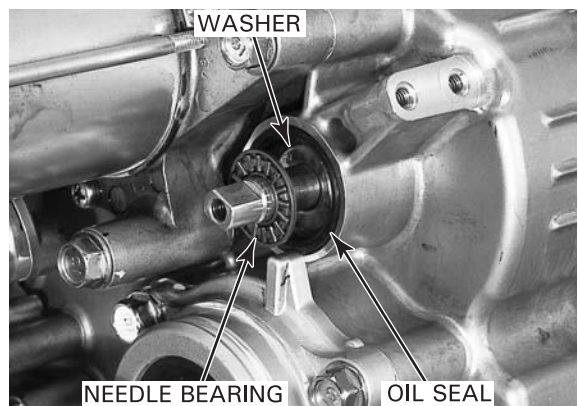

## REVERSE SHIFTER/SHIFT DRUM LOCK ARM REMOVAL

Remove the rear crankcase cover (page 10-11).

Remove the following:

- starter reduction gear and shaft
- washer
- reverse idle gear

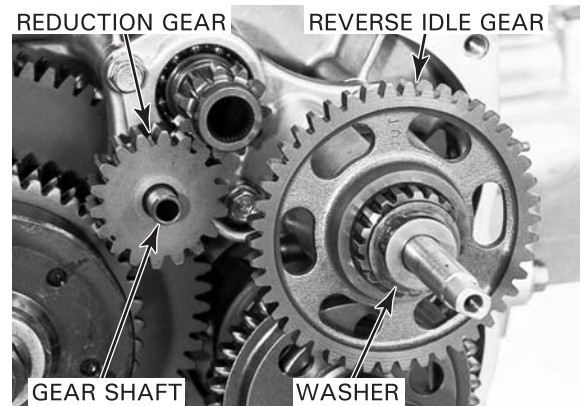

- reverse shifter shaft assembly

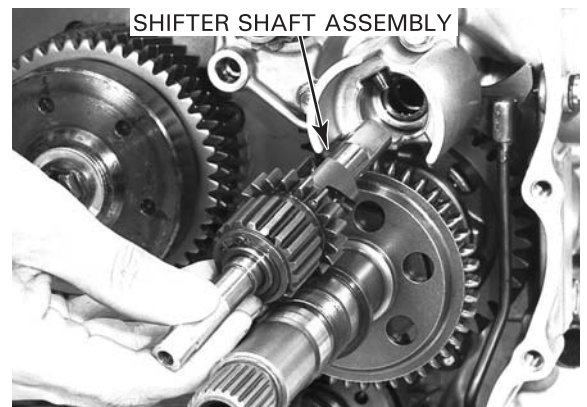

- three bolts
- starter drive gear holder
- two dowel pins

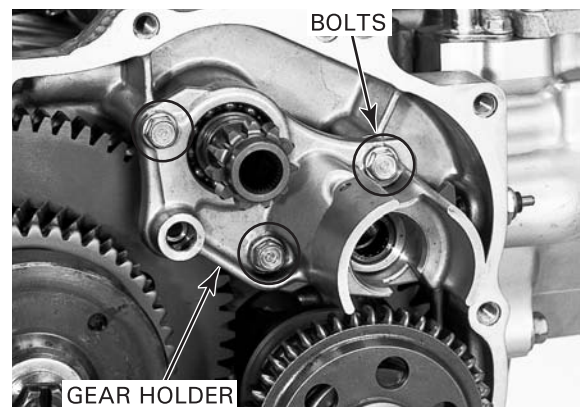

- bolt
- shift drum lock arm assembly

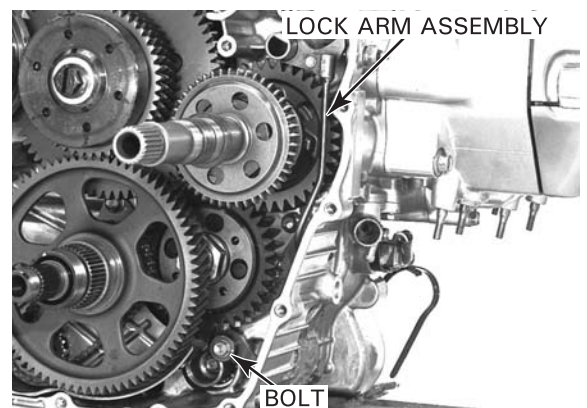

## STARTER/REVERSE SYSTEM

### DISASSEMBLY/INSPECTION

Remove the roller pin and reverse shifter assembly from the shaft.

Check the reverse shifter shaft for wear or damage.

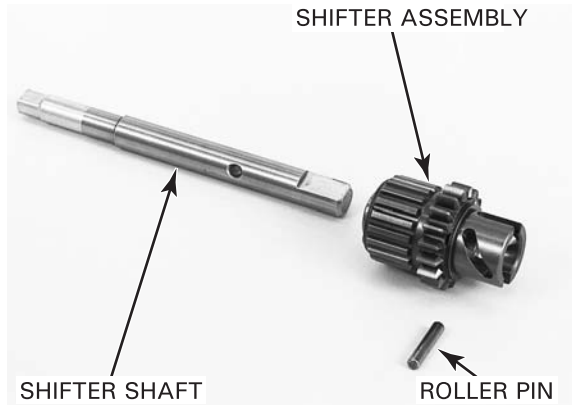

Remove the snap ring and disassemble the shifter assembly.

Check the shifter gear, needle bearings and shifter for wear or damage.

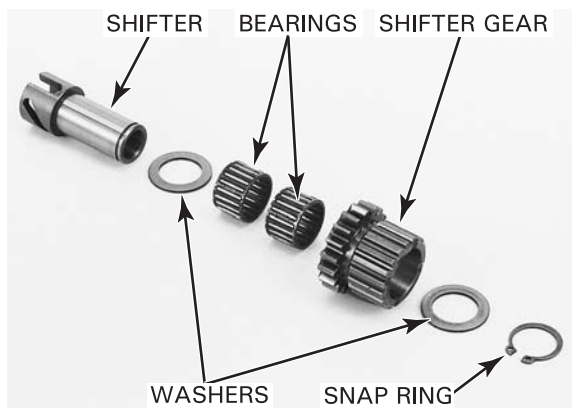

Check the drive gear teeth for wear or damage.  
Turn the drive gear and check the bearing condition.  
The bearing should turn smoothly and quietly.  
Also check that the outer race of the bearing fits tightly in the holder.

Replace the bearing if the drive gear does not turn smoothly, quietly, or if the outer race fits loosely in the holder.

Check the reverse shifter shaft bearing for wear or damage.

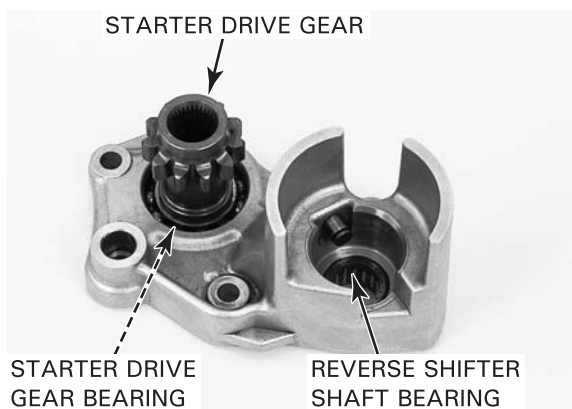

Check the shift drum lock arm assembly for distortion, damage or wear.



**BEARING REPLACEMENT**

**STARTER DRIVE GEAR BEARING**

Support the gear holder and press the starter drive gear out of the bearing using the special tools.

**TOOLS:**

**Pilot, 20 mm** 07746-0040500  
**Assembly collar** 07965-VM00100

Press the bearing out of the gear holder using the special tools.

**TOOLS:**

**Driver** 07749-0010000  
**Attachment, 32 x 35 mm** 07746-0010100  
**Fork seal driver** 07947-4630100

Support the gear holder and press the bearing into the holder using the special tools.

**TOOLS:**

**Driver** 07749-0010000  
**Attachment, 37 x 40 mm** 07746-0010200  
**Pilot, 20 mm** 07746-0040500  
**Attachment, 20 mm I.D.** 07746-0020400

*Use the small I.D. of the special tool to support the bearing inner race.*

Support the bearing inner race with the special tool and press the starter drive gear into the bearing.

**TOOL:**

**Attachment, 20 mm I.D.** 07746-0020400

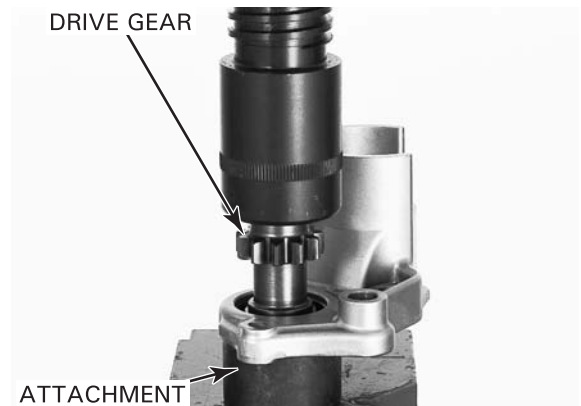
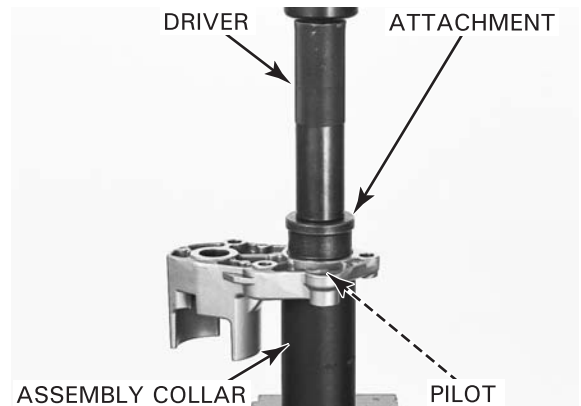
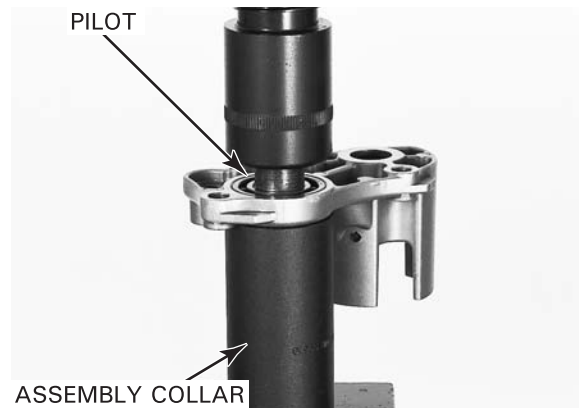

**REVERSE SHIFTER SHAFT BEARING**

Remove the starter drive gear.

Drive the reverse stopper shaft and collar out of the gear holder.

**TOOL:**

**07944-SA00000 or equivalent commercially available in U.S.A.**

**Pin driver, 4 mm**

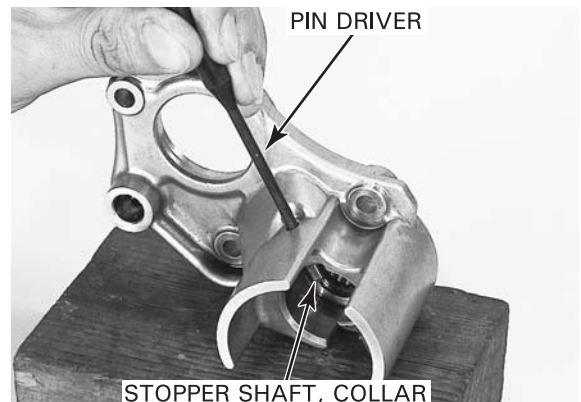



## STARTER/REVERSE SYSTEM

Press the reverse shifter shaft bearing out of the gear holder using a suitable tool.

Press a new needle bearing into the gear holder using the special tool.

### TOOLS:

**Driver** 07749-0010000

**Attachment, 24 x 26 mm** 07746-0010700

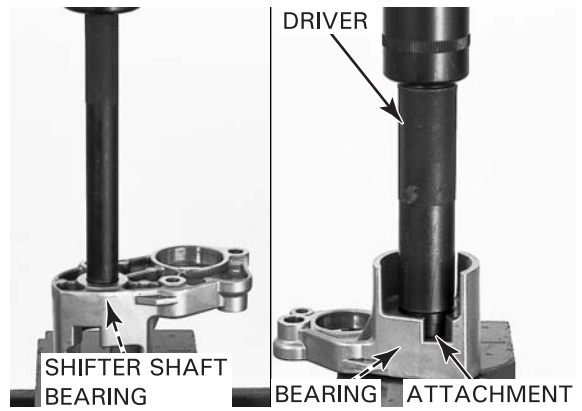

Drive the reverse stopper shaft with its collar into the gear holder so that the height from the holder is 6.7 – 7.3 mm (0.26 – 0.29 in).



## SHIFT DRUM LOCK ARM/REVERSE SHIFTER INSTALLATION

Apply molybdenum disulfide grease to the lock arm pivot.

Apply locking agent to the shift drum lock arm bolt threads.

Install the shift drum lock arm assembly and tighten the bolt.

**TORQUE: 12 N·m (1.2 kgf·m, 9 lbf·ft)**

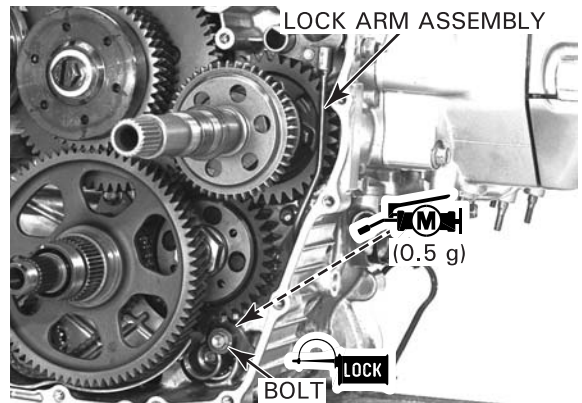

Apply oil to the starter drive gear bearing and install the drive gear into the gear holder.

Apply oil to the reverse shifter shaft bearing.

Apply molybdenum oil solution to the reverse stopper shaft and collar.

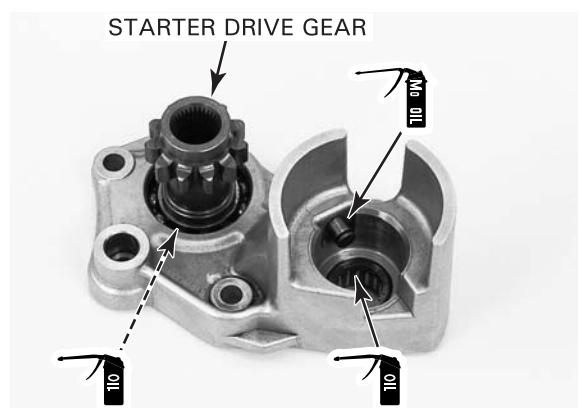



## STARTER/REVERSE SYSTEM

Install the two dowel pins into the crankcase.

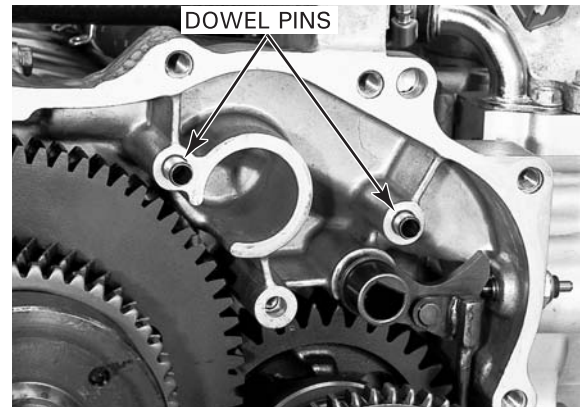

Install the starter drive gear holder and tighten the three bolts securely.

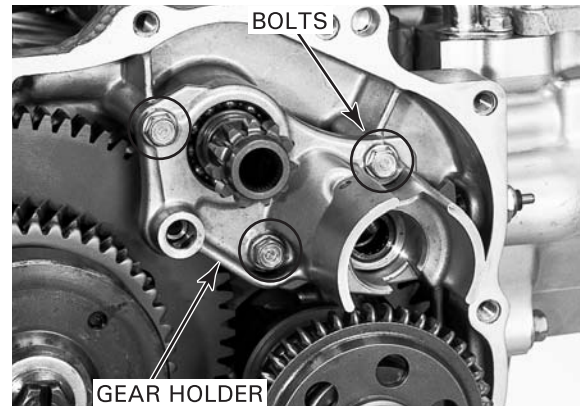

Apply oil to the needle bearings.  
Apply molybdenum oil solution to the shifter guide (holes), groove and shifter gear splines.  
Install the washer, needle bearings, shifter gear and washer onto the reverse shifter.

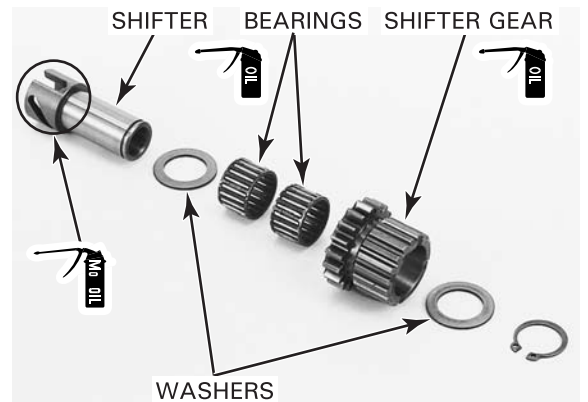

Install the snap ring with the chamfered side facing in.

Check that the shifter gear turns smoothly.

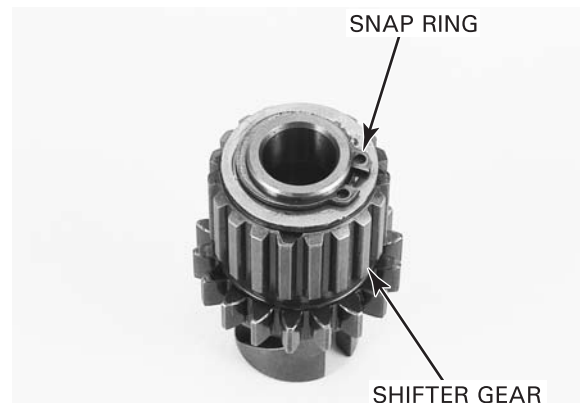
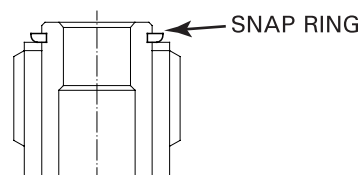

## STARTER/REVERSE SYSTEM

Coat the reverse shifter shaft with molybdenum oil solution.  
Install the reverse shifter assembly onto the shaft.  
Coat the roller pin with grease.  
Install the roller pin into the hole in the shaft through the guide holes in the shifter.

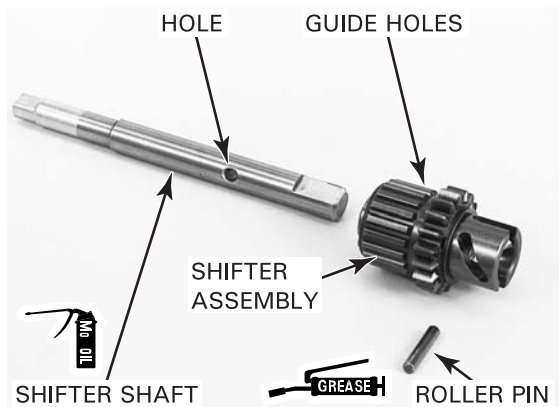

Install the reverse shifter shaft assembly into the shift drum lock arm while aligning the flat on the shaft end with the flat in the lock arm hole.

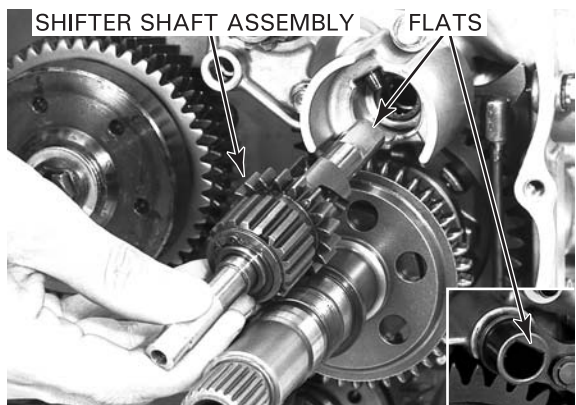

Further insert the shifter shaft assembly while aligning the shifter groove with the stopper shaft

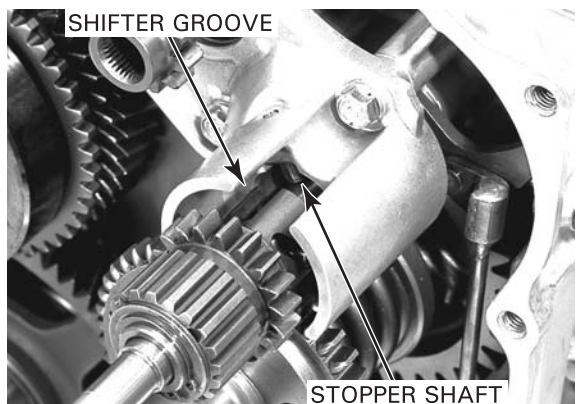

Install the reverse idle gear with the "OUT" mark facing out.  
Install the washer.

Coat the starter reduction gear shaft with molybdenum oil solution and install it into the gear holder.  
Install the starter reduction gear onto the shaft.

Install the rear crankcase cover (page 10-24).

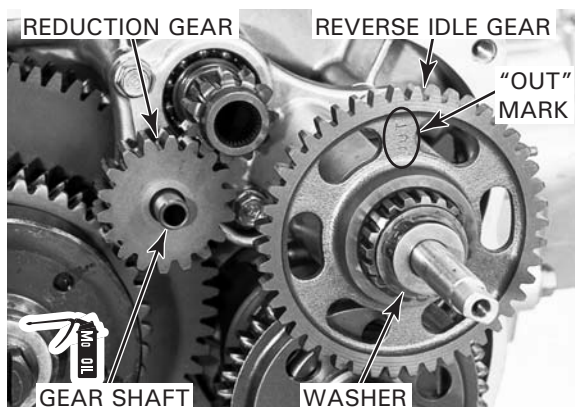

**REVERSE SHIFT ARM INSTALLATION**

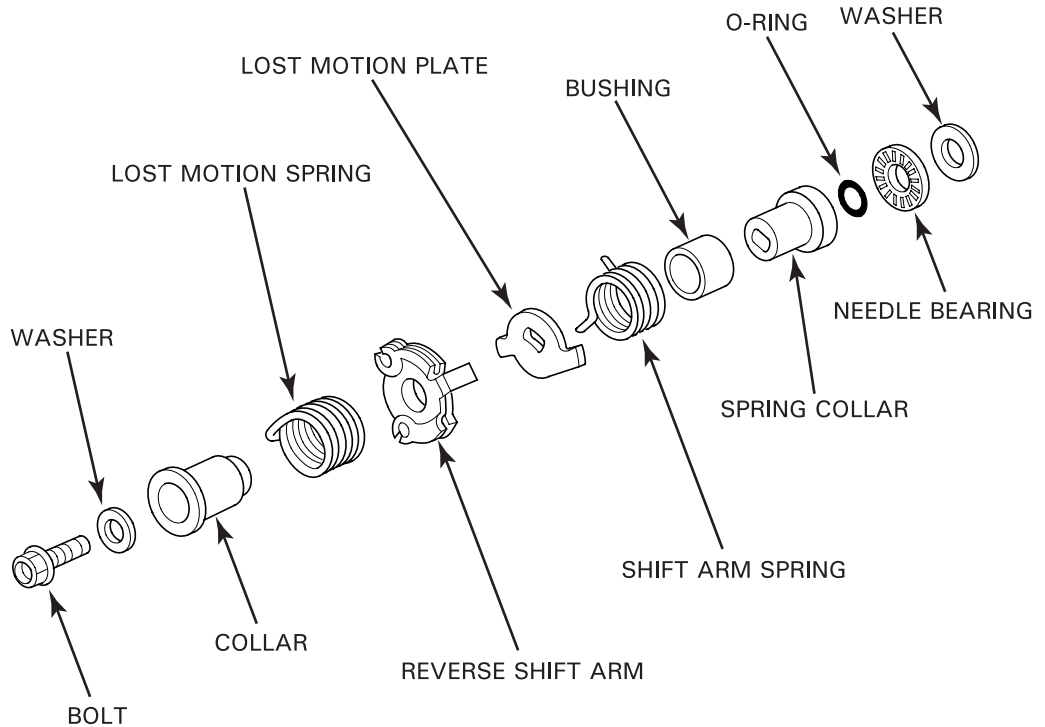

Apply grease to the lip of a new oil seal and install the seal into the rear crankcase cover. Coat the needle bearing with molybdenum oil solution and install the washer and needle bearing onto the reverse shifter shaft.

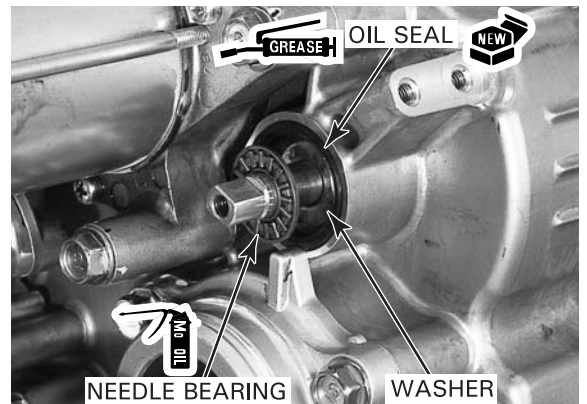

Coat a new O-ring with oil and install it into the spring collar. Install the spring collar onto the reverse shifter shaft.

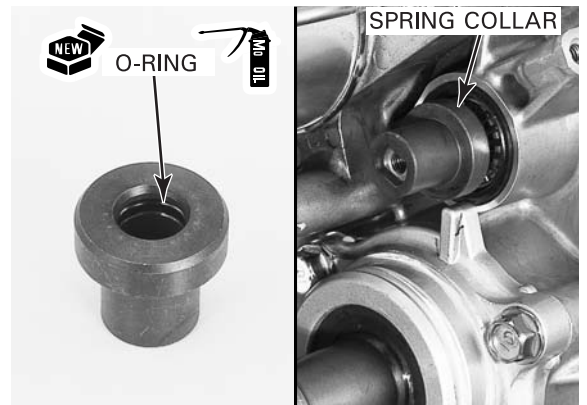

## STARTER/REVERSE SYSTEM

Apply molybdenum disulfide grease to the inner and outer surfaces of the spring bushing. Install the bushing, reverse shift arm spring and lost motion plate.

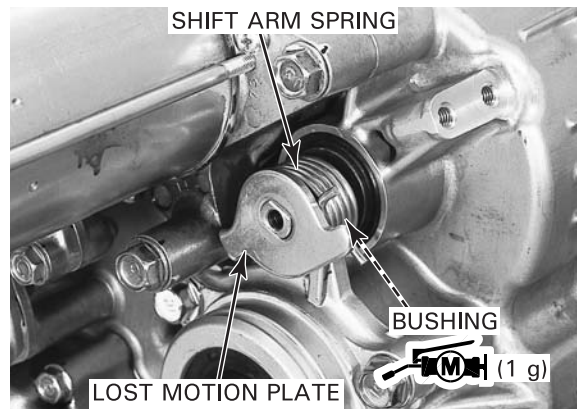

Install the reverse shift arm and lost motion spring over the shaft and plate while hooking the spring ends properly as shown.

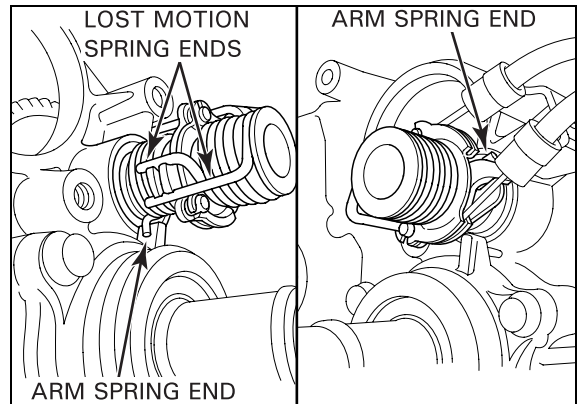

Apply locking agent to the reverse shifter shaft bolt threads. Install the collar, washer and shaft bolt, and tighten the bolt.

**TORQUE: 14 N·m (1.4 kgf·m, 10 lbf·ft)**

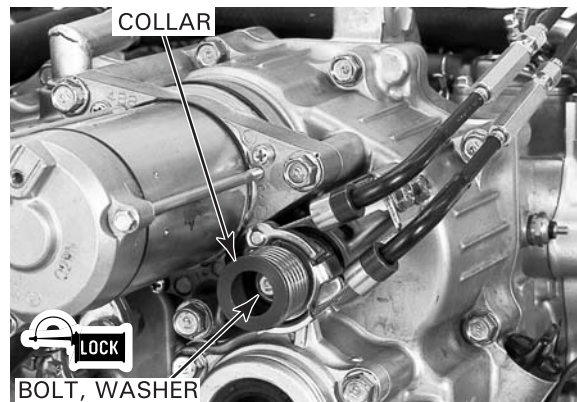

Apply locking agent to the cable holder bolt threads. Install the cable holder, ground cable terminal and holder bolts, and tighten the bolts.

**TORQUE: 12 N·m (1.2 kgf·m, 9 lbf·ft)**

Check the reverse shift actuator cables and adjust them if necessary (page 19-38).

Install the rear brake master cylinder (page 15-19).

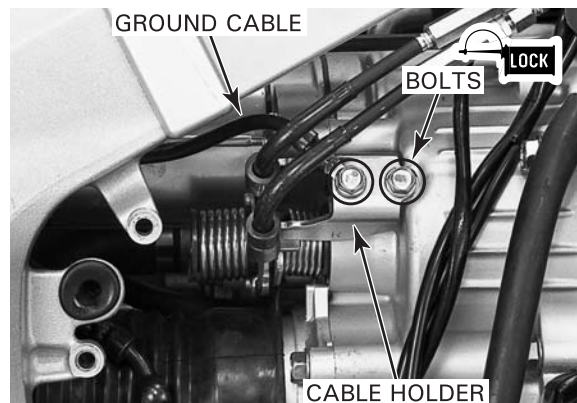

# 20. LIGHTS/METERS/SWITCHES

---

SYSTEM LOCATION.....	20-2	OIL PRESSURE INDICATOR .....	20-27
SERVICE INFORMATION .....	20-3	TURN SIGNAL RELAY.....	20-27
TROUBLESHOOTING .....	20-4	TURN SIGNAL CANCEL UNIT .....	20-28
HEADLIGHT.....	20-8	POSITION LIGHT RELAY.....	20-31
HEADLIGHT ADJUSTER .....	20-9	HAZARD SWITCH.....	20-32
FRONT TURN SIGNAL LIGHT.....	20-13	OPEN AIR TEMPERATURE SENSOR .....	20-33
SADDLEBAG COMBINATION LIGHT .....	20-14	IGNITION SWITCH .....	20-34
TRUNK BRAKE/TAILLIGHT.....	20-15	HANDLEBAR SWITCH.....	20-35
LICENSE LIGHT.....	20-15	BRAKE SWITCH.....	20-37
RELAY BOX.....	20-16	CLUTCH SWITCH .....	20-37
COMBINATION METER.....	20-17	GEAR POSITION SWITCH.....	20-38
SPEEDOMETER .....	20-20	SIDE STAND SWITCH .....	20-39
TACHOMETER .....	20-21	MULTI-DISPLAY CONTROL SWITCH.....	20-40
COOLANT TEMPERATURE GAUGE/ ECT SENSOR .....	20-22	HORN .....	20-40
FUEL GAUGE/LOW FUEL INDICATOR ....	20-24	FAN CONTROL RELAY.....	20-41
NEUTRAL INDICATOR .....	20-26	POWER TRUNK LOCK SYSTEM.....	20-42



SYSTEM LOCATION

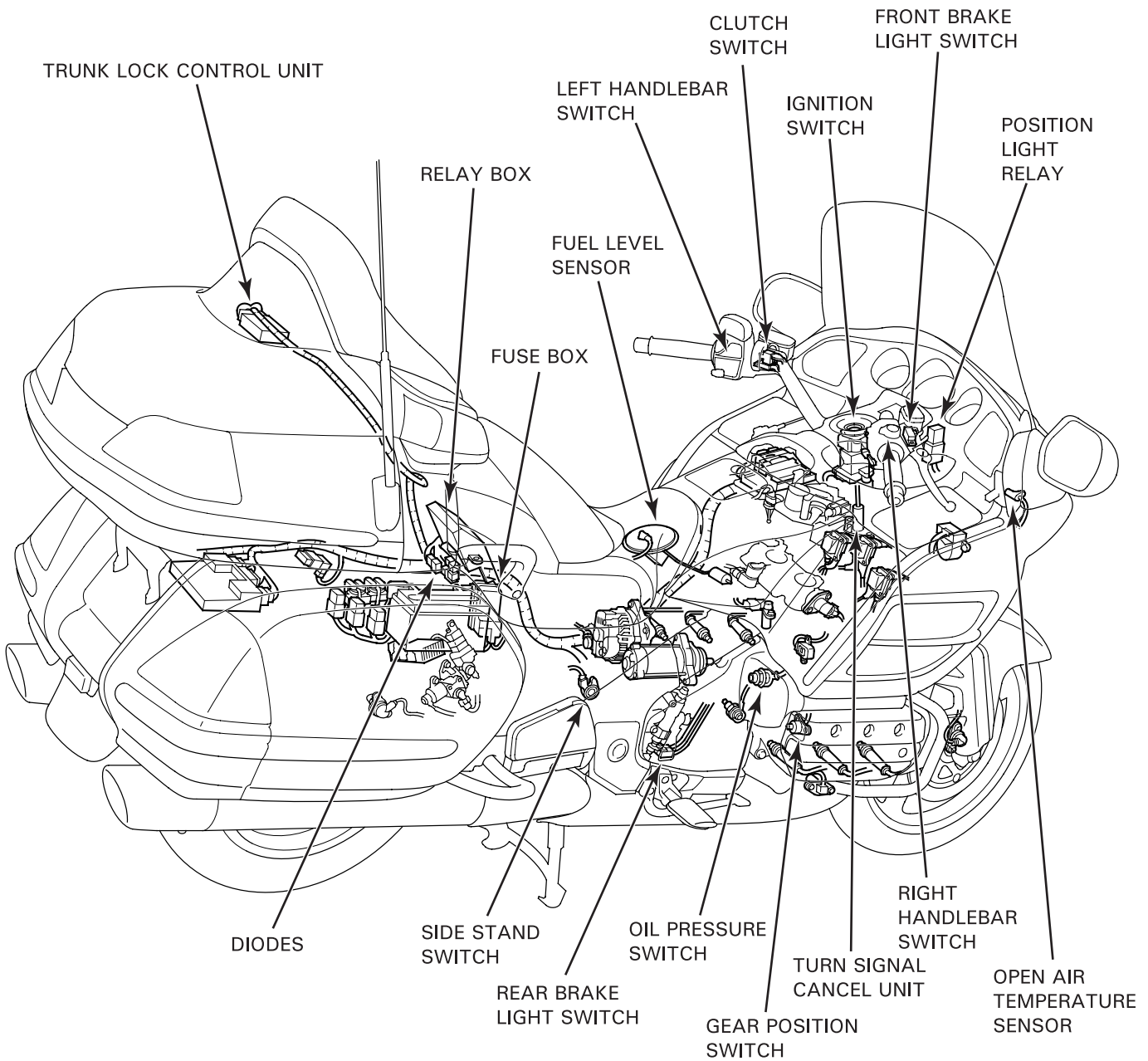



# SERVICE INFORMATION

## GENERAL

### NOTICE

A halogen headlight bulb becomes very hot while the headlight is on, and remains hot for a while after it is turned off. Be sure to let it cool down before servicing.

- Use an electric heating element to heat the water/coolant mixture for the thermosensor inspection. Keep all flammable materials away from the electric heating element. Wear protective clothing, insulated gloves and eye protection.
- Note the following when replacing the halogen headlight bulb.
  - Wear clean gloves while replacing the bulb. Do not put fingerprints on the headlight bulb, as they may create hot spots on the bulb and cause it to fail.
  - If you touch the bulb with your bare hands, clean it with a cloth moistened with alcohol to prevent an early failure.
  - Be sure to install the dust cover after replacing the bulb.
- Check the battery condition before performing any inspection that requires proper battery voltage.
- A continuity test can be made with the switches installed on the motorcycle.
- When checking the turn signal/hazard system, always follow the steps in the troubleshooting flow chart (page 20-5).
- The following color codes used are indicated throughout this section.

Bl: Black	G: Green	Lg: Light Green	R: Red
Br: Brown	Gr: Gray	O: Orange	W: White
Bu: Blue	Lb: Light Blue	P: Pink	Y: Yellow

## SPECIFICATIONS

ITEM		SPECIFICATIONS
Bulbs	Headlight (high beam)	12 V – 55 W x 2
	Headlight (low beam)	12 V – 55 W x 2
	Brake/taillight	12 V – 21/5 W x 6
	License light	12 V – 3CP (5W)
	Front turn signal/running light	12 V – 21/5 W x 2
	Rear turn signal light	12 V – 21 W x 2
Fuse	Main fuse A	30A
	Main fuse B	100A
	Reverse speed limiter fuse	70A
	Sub-fuse	20A x 3, 15A x 8, 10A x 3, 5A x 4 (ABS model: 5A x 5)
	Modulator fuse (ABS model)	30 A x 2
ECT sensor resistance	At 80° C (176° F)	47 – 57Ω
	At 120° C (248° F)	14 – 18Ω

## TORQUE VALUES

Side stand switch bolt	12 N·m (1.2 kgf·m, 9 lbf·ft)
Ignition switch mounting bolt	25 N·m (2.5 kgf·m, 18 lbf·ft)

## TOOL

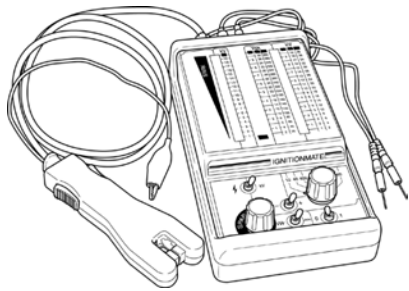
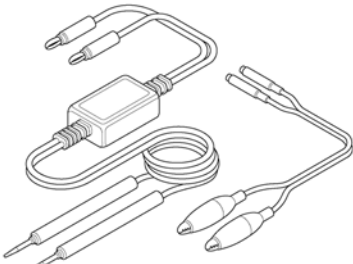
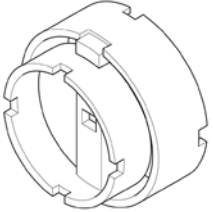
<p>IgnitionMate peak voltage tester MTP07-0286 (U.S.A. only)</p> 	<p>Peak voltage adaptor 07HGJ-0020100</p>  <p>(not available in U.S.A.) with commercially available digital multimeter (impedance 10 MΩ/DCV minimum)</p>	<p>Fuel sender/pump wrench 07ZMA-MCAA201 (U.S.A. only)</p>  <p>or 07ZMA-MCAA200 (U.S.A. only)</p>
--	--	--

## LIGHTS/METERS/SWITCHES

---

### TROUBLESHOOTING

- Check the following before troubleshooting:
  - faulty or under-charged battery
  - blown main fuse B (100 A) and No. 2 main fuse A (30 A)
  - Check the ignition switch and its circuit if all systems do not function when the ignition switch is turned to “ON.”
- Check for open circuit in the Green (ground) wire for each part.

### LIGHTING SYSTEM

NOTE:

- The headlights go off when the starter/reverse switch is pushed for starting.
- The low beam headlights remain on when the starter/reverse switch is pushed for reverse running.

#### **Low beam headlights do not light with the ignition switch turned to “ON”**

- Faulty bulbs
- Faulty HEADLIGHT LO relay (page 20-16)
- Faulty starter/reverse switch (page 20-35)
- Faulty diode (D21)
- Blown No. 9 fuse or No. 26 fuse (Check for a short circuit in the related wires if the fuse is blown again.)
- Loose or poor contact of related connectors
- Open circuit in related wires

#### **Low beam headlights go off during reverse running**

- Open circuit in the Blue wire between the headlight LO relay and reverse regulator assembly
- Faulty diode (D8) (page 19-28)
- Open circuit in the White/blue wire between the reverse position switch and reverse regulator assembly
- Loose or poor contact of related connectors

#### **Both high beam headlights do not light with the dimmer switch pushed to “”**

- Faulty dimmer switch (page 20-36)
- Open circuit in the Blue/white wire between the starter/reverse switch and dimmer switch

#### **Left high beam headlight does not light with the dimmer switch pushed to “”**

- Faulty bulb
- Open circuit in the Blue wire between the left headlight and dimmer switch
- Loose or poor contact of related connectors

#### **Right high beam headlight does not light with the dimmer switch pushed to “”**

- Faulty bulb
- Faulty HEADLIGHT HI relay (page 20-16)
- Blown No. 24 fuse (Check for a short circuit in the related wires if the fuse is blown again.)
- Loose or poor contact of related connectors
- Open circuit in related wires

#### **Taillights and meter lights do not light with the ignition switch turned to “ON”**

- Faulty TAIL relay (page 20-16)
- Blown No. 5 fuse (Check for a short circuit in the related wires if the fuse is blown again.)
- Loose or poor contact of related connectors
- Open circuit in related wires

#### **Brake lights do not come on when the brake is applied with the ignition switch turned to “ON”**

- Faulty brake light switch (page 20-37)
- Faulty STOP LIGHT relay (page 20-16)
- Faulty HORN TURN relay (page 20-16)
- Blown No. 18 fuse (Check for a short circuit in the related wires if the fuse is blown again.)
- Loose or poor contact of related connectors
- Open circuit in related wires

**TURN SIGNAL/HAZARD LIGHT SYSTEM**

**NOTE:**

- The turn signal lights blink faster than normal if one bulb is burnt out.

**All turn signal lights do not operate**

**1. Turn Signal Switch Inspection**

Check the turn signal switch (page 20-28).

***Is the turn signal switch operating properly?***

**NO** – Faulty turn signal switch.

**YES** – GO TO STEP 2.

**2. Turn Signal Relay Power Input Voltage Inspection**

Check the turn signal relay power input line (page 20-27).

***Is there battery voltage?***

**NO** – • Open circuit in the Light green/black wire between the turn signal relay and ACC relay.  
 • Loose or poor contact of the related connectors.  
 • Faulty ACC relay or its circuits (page 20-16).

**YES** – GO TO STEP 3.

**3. Turn Signal Light Inspection**

Connect the Light green/black and Gray wire terminals of the meter 3P connector with a jumper wire.

Turn the ignition switch to “ON” and operate the turn signal switch.

***Do the turn signal lights come on?***

**NO** – • Open circuit in the Gray wire between the turn signal relay and turn signal switch.  
 • Loose or poor contact of the related connectors.

**YES** – GO TO STEP 4.

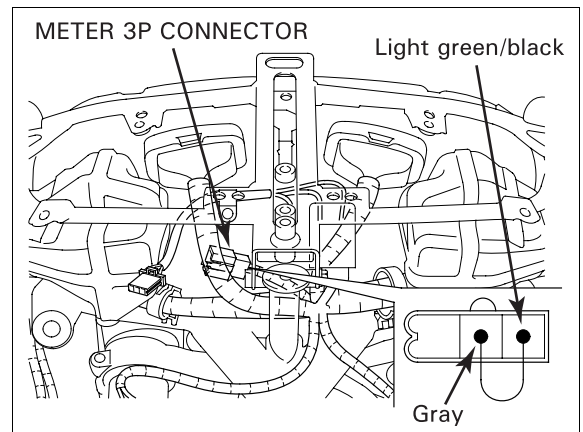

**4. Turn Signal Relay Inspection**

Check the turn signal relay (page 20-27).

***Is the turn signal relay operating properly?***

**NO** – Faulty turn relay.

**YES** – GO TO STEP 5.

**5. Turn Signal Cancel Unit Inspection**

Perform the turn signal cancel unit system inspection (page 20-28).

***Does the turn signal system pass the inspection?***

**NO** – • Open or short circuit in the wire harness (page 20-28).  
 • Loose or poor contact of the related connectors.

**YES** – Faulty turn signal cancel unit.

## LIGHTS/METERS/SWITCHES

---

### Turn signals do not cancel automatically

#### 1. Angle Sensor Inspection

Check the angle sensor of the turn signal cancel unit (page 20-30).

##### *Does the angle sensor rotate freely?*

**NO** – Damaged or improperly installed angle sensor plate.

**YES** – GO TO STEP 2.

#### 2. Speed Pulse Signal Line Inspection

Check the speed pulse signal line of the turn signal cancel unit (page 20-29).

##### *Is the voltage within specified value?*

**NO** – • Open or short circuit in the White/black wire between the turn signal cancel unit and combination meter.  
• Loose or poor contact of the related connectors.  
• Faulty combination meter.

**YES** – Faulty turn signal cancel unit.

### Turn signals do not cancel manually

#### 1. Turn Signal Switch Inspection

Check the turn signal switch (page 20-27).

##### *Is the turn signal switch operating properly?*

**NO** – Faulty turn signal switch.

**YES** – GO TO STEP 2.

#### 2. Turn Signal Off Signal Line Inspection

Check the turn signal off signal line of the turn signal cancel unit (page 20-28).

##### *Is there continuity?*

**NO** – • Open circuit in the Light green/white wire between the turn signal cancel unit and turn signal switch.  
• Loose or poor contact of the related connectors.

**YES** – Faulty turn signal cancel unit.

### Position lights do not light with the ignition switch turned to "ON"

- Faulty turn signal switch (page 20-27)
- Open circuit in the Brown/white wire between the TAIL relay and turn signal switch
- Open circuit in the Light blue/white or Orange/white wire between the turn signal switch and turn signal light
- Faulty position light relay and its circuits (page 20-31)

### Opposite position light does not go off when the turn signal switch is operated

- Faulty turn signal switch (page 20-27)
- Faulty position light relay and its circuits (page 20-31)
- Faulty diode (D20) (page 20-33)

Turn signal system operates properly but hazard system does not operate

1. Hazard Switch Inspection

Check the hazard switch (page 20-32).

**Is the hazard switch operating properly?**

**NO** - Faulty hazard switch; replace the left panel switch assembly (page 20-32).

**YES** - GO TO STEP 2.

2. Hazard Switch Ground Line Continuity Inspection

Check for continuity between the Green wire terminal of the wire harness side panel switch 14P connector and ground.

**Is there continuity?**

**NO** - Open circuit in the Green wire between the hazard switch and ground terminal.

**YES** - GO TO STEP 3.

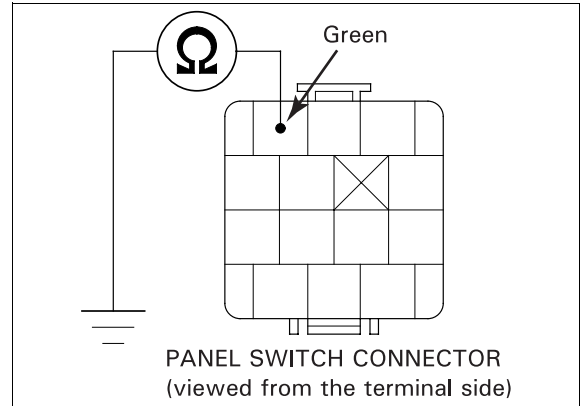

3. Hazard Switch Line Continuity Inspection

Disconnect the combination meter 3P connector (page 20-17).

Check for continuity of the following wires between the panel switch 14P connector and meter 3P connector.

- Gray
- Blue/green

**Is there continuity?**

**NO** - • Open circuit in the following wires:  
 - Gray  
 - Blue/green

**YES** - • Faulty diodes (D12, D13) (page 20-33).  
 • Open circuit in the Pink/white wire between the hazard switch and diodes.  
 • Open circuit in the Orange or Light blue wire.

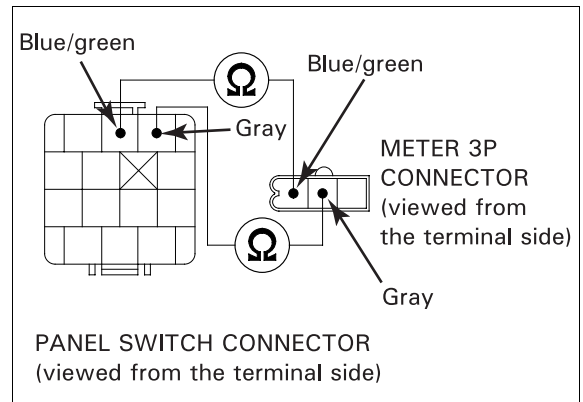

# HEADLIGHT

## BULB REPLACEMENT

A halogen headlight bulb becomes very hot while the headlight is on, and will remain hot for a while after it is turned off. Be sure to let it cool down before servicing.

For high beam bulb, remove the fairing pocket (page 2-11).

Disconnect the headlight connector.

Remove the dust cover.

Unhook the bulb retainer, remove the bulb socket and replace the headlight bulb with a new one.

### NOTICE

*Avoid touching a halogen headlight bulb. Finger prints can create hot spots that cause a bulb to break.*

If you touch the bulb with your bare hands, clean it with a cloth moistened with alcohol to prevent an early failure.

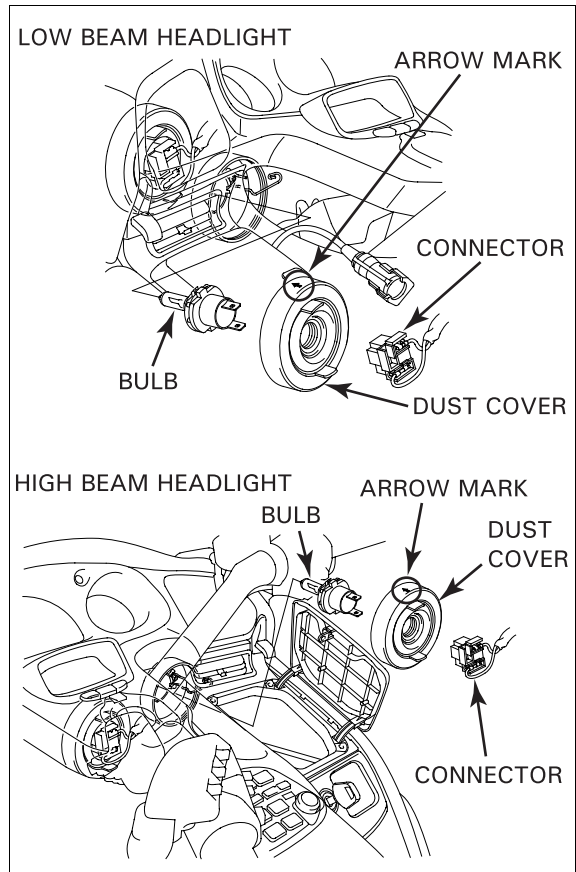

Install the bulb/socket into the headlight and hook the bulb retainer properly as shown.

Install the dust cover properly onto the headlight with the arrow mark facing up. Connect the headlight connector.

Install the fairing pocket (page 2-11).

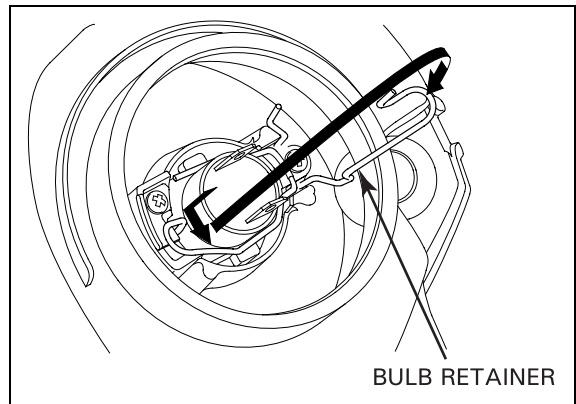

## REMOVAL/INSTALLATION

Remove the front fairing (page 2-10).

Remove the two screws and bank angle sensor assembly from the right headlight.

Remove the two bolts, nuts and joint plate. Remove the four bolts and the headlight unit from the front fairing.

Install the headlight unit in the reverse order of removal.

Perform the same procedure for the left headlight; however, there is no bank angle sensor.

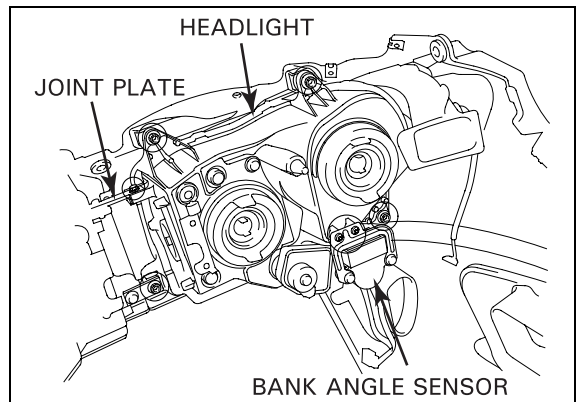



# HEADLIGHT ADJUSTER

## SYSTEM INSPECTION

### Headlight adjuster does not operate

- Turn the ignition switch to "ON" and check that the headlight low beams go on.
  - If the headlights are on, go to step 2.
  - If the headlights do not light, check the No. 9 fuse in the fuse box.
- Turn the ignition switch "OFF."  
Remove the inner fairings (page 2-10).  
Disconnect the 3P gray connector from each headlight adjuster and check for loose contacts or corroded terminals.

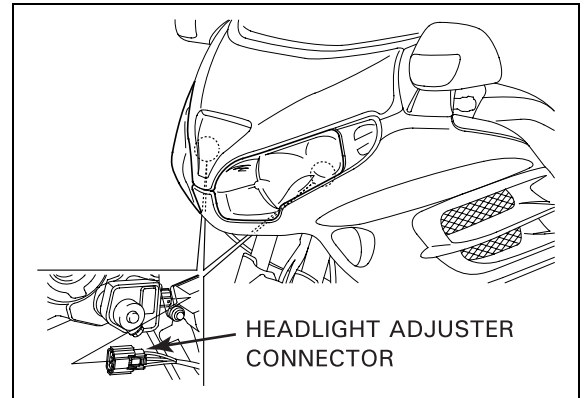

- Check for continuity between the Green wire terminal and ground.  
There should be continuity.
  - If there is continuity, go to step 4.
  - If there is no continuity, check for an open circuit in the Green wire between the headlight adjuster and ground terminal.

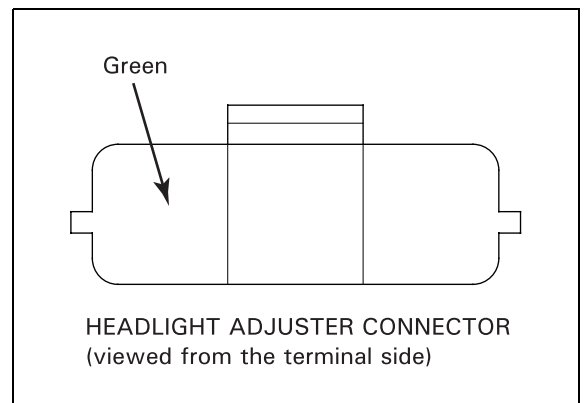

- Start the engine and let it idle.  
Measure the voltage between the Brown/red wire terminal (+) and ground (-).  
There should be battery voltage.
  - If there is battery voltage, go to step 5.
  - If there is no voltage, check for:
    - open circuit in the Brown/red and Brown wires between the headlight adjuster and relay
    - headlight adjuster relay system (page 20-11)

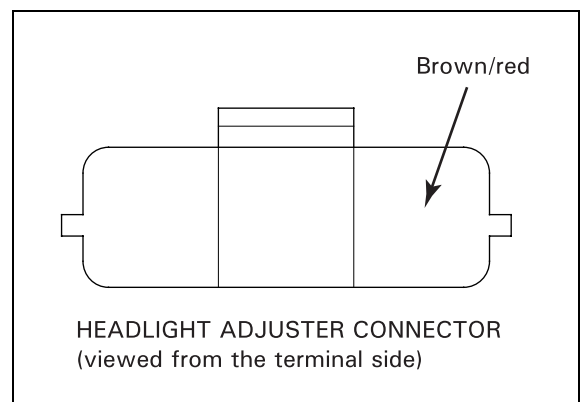

## LIGHTS/METERS/SWITCHES

5. Connect the voltmeter between the Light green wire terminal (+) and ground (-). Check that the voltage varies with the headlight adjusting switch position while operating the switch.

**STANDARD: 1.2–10.8 V**

- If the voltage is normal, replace the headlight adjuster (page 20-9).
- If the voltage is abnormal, check for:
  - open or short circuit in the Light green wire between the headlight adjuster and adjusting switch
  - headlight adjusting switch system (page 20-9)

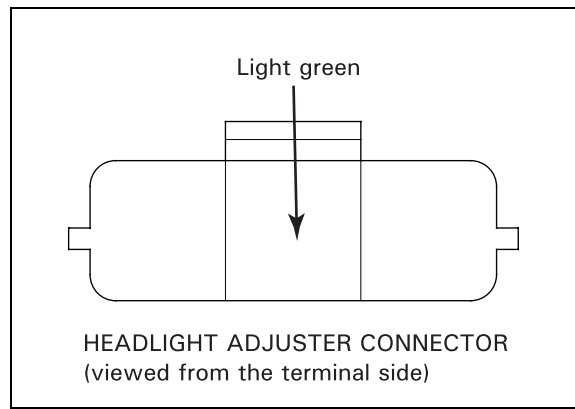

## REPLACEMENT

Remove the inner fairing (page 2-10).

Disconnect the headlight adjuster 3P gray connector.

Right headlight adjuster: Turn the adjuster clockwise.

Left headlight adjuster: Turn the adjuster counterclockwise.

Turn the adjusting bolt counterclockwise and remove the headlight adjuster from the headlight.

Install the headlight adjuster in the reverse order of removal.

Adjust the headlight beam (page 3-19).

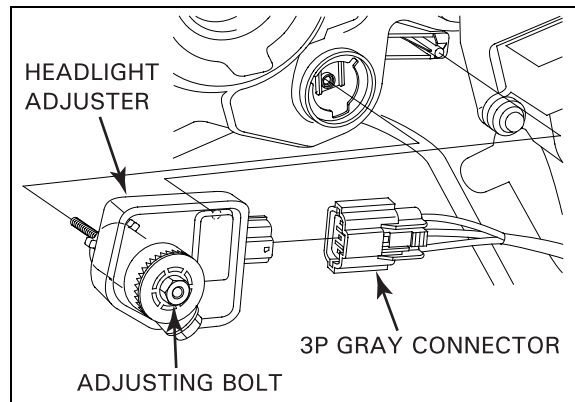

## HEADLIGHT ADJUSTING SWITCH SYSTEM INSPECTION

1. Turn the ignition switch to "OFF."  
Remove the left fairing pocket (page 2-11).  
Disconnect the left panel switch assembly 14P gray connector and check for loose contacts or corroded terminals.

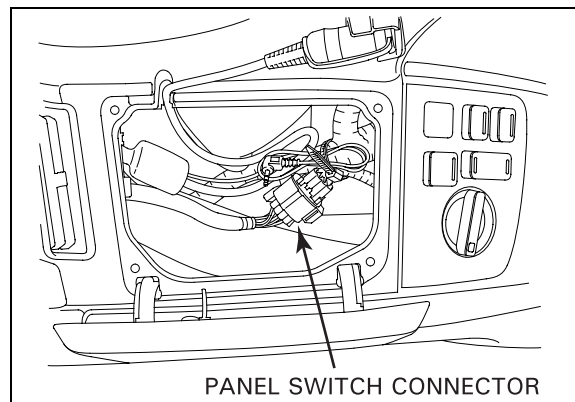

2. Measure the resistance between the Yellow/red and Blue/green wire terminals of the switch side connector.

**STANDARD: 4.0–6.0 kΩ**

- If the resistance is normal, go to step 3.
- If the resistance is abnormal, replace the panel switch assembly (page 20-32).

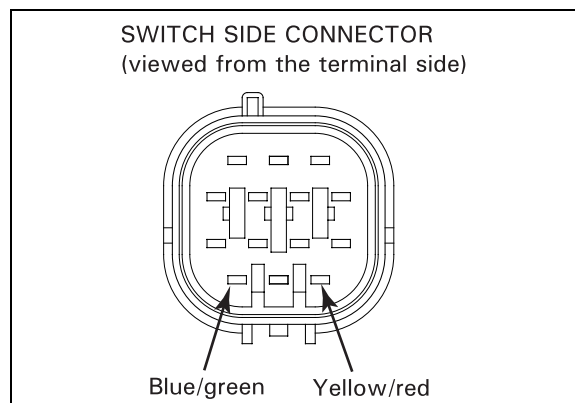

3. Check that the resistance between the Yellow/blue and Blue/green wire terminals varies with the headlight adjusting switch position while operating the switch.

**Clockwise (from Lo to Hi position):**

**Resistance increases**

**Counterclockwise (from Hi to Lo position):**

**Resistance decreases**

- If the measurements are normal, go to step 4.
- If the measurements are abnormal, replace the panel switch assembly (page 20-32).

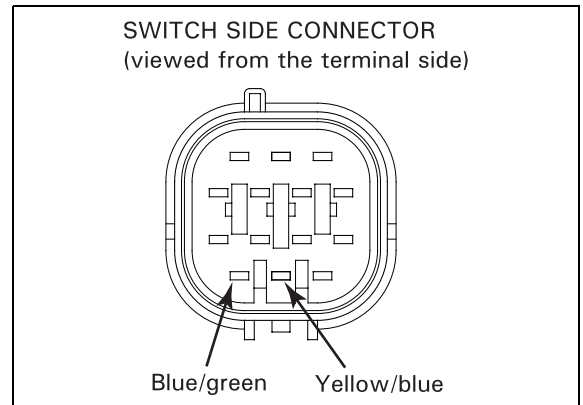

4. Check for continuity between the Green wire terminal of the wire harness side connector and ground.

There should be continuity.

- If there is continuity, go to step 5.
- If there is no continuity, check for an open circuit in the Green wire between the panel switch connector and ground terminal.

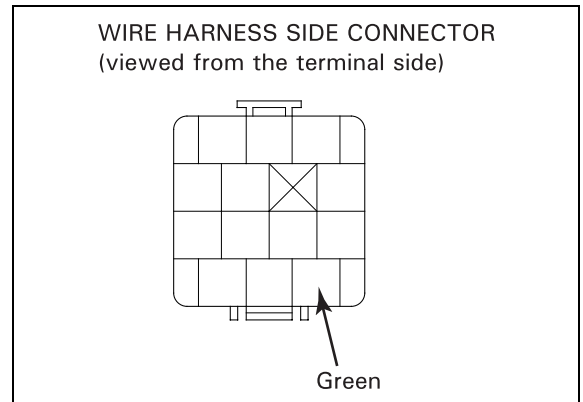

5. Start the engine and let it idle.

Measure the voltage between the Brown/red wire terminal (+) and ground (-).

There should be battery voltage.

- If there is battery voltage, the system is OK.
- If there is no battery voltage, check for:
  - open circuit in the Brown/red wire between the panel switch connector and headlight adjuster relay
  - headlight adjuster relay system

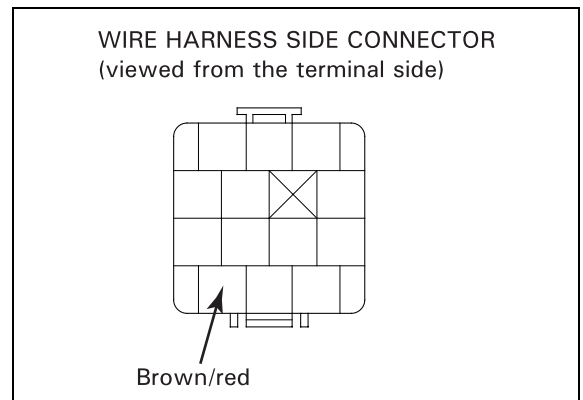

**HEADLIGHT ADJUSTER RELAY SYSTEM INSPECTION**

1. Turn the ignition switch to "ON" and check that the oil pressure indicator comes on. Start the engine and check that the oil pressure indicator goes off.

- If the indicator goes off, go to step 2.
- If the indicator remains on, check the oil pressure switch (page 20-13).

## LIGHTS/METERS/SWITCHES

- Turn the ignition switch to "OFF" and remove the seat (page 2-5).  
Remove the two screws and remove the relay box.  
Remove the relay blocks from the relay box.

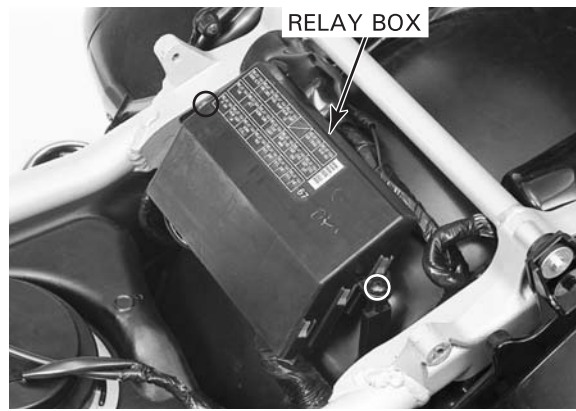

- Exchange the headlight adjuster relay with the other good one.  
Start the engine, let it idle and operate the headlight adjusting switch.
  - If the headlight adjuster functions properly, replace the headlight adjuster relay with a new one.
  - If the headlight adjuster does not function, go to step 4.



- Turn the ignition switch to "OFF" and remove the headlight adjuster relay.  
Check for continuity between the Blue/white wire terminal of the relay connector and ground.  
Start the engine and let it idle.  
There should be no continuity.
  - If there is no continuity, go to step 5.
  - If there is continuity, check for:
    - short circuit in the Blue/white wire between the headlight adjuster relay and oil pressure switch diode (D17)
    - faulty diode (D17)

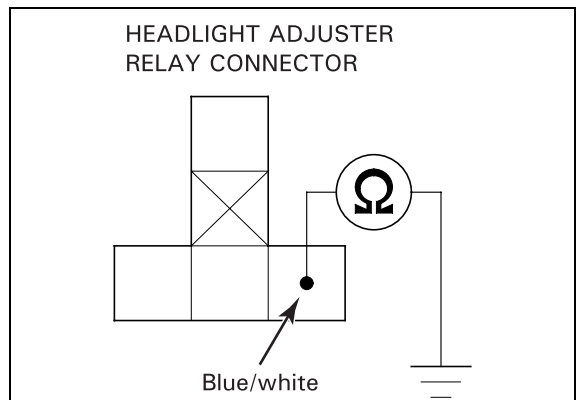

- Stop the engine then turn the ignition switch to "ON."  
Measure the voltage between the Brown/red wire terminal (+) of the relay connector and ground (-).  
There should be battery voltage.
  - If there is battery voltage, the system is OK; check for loose contacts or corroded terminals.
  - If there is no voltage, check for an open circuit in the Brown/red wire between the headlight adjuster relay and fuse box (No. 9 fuse).

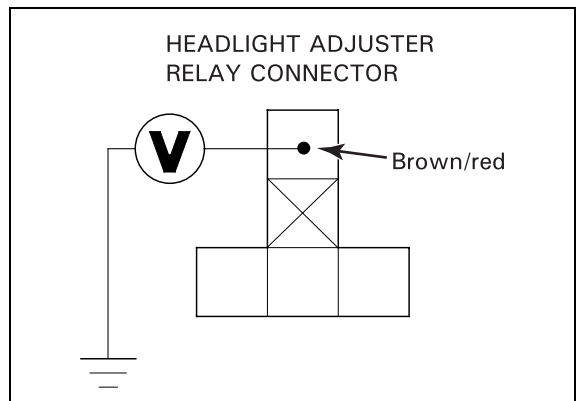

**OIL PRESSURE SWITCH DIODE**

Remove the seat (page 2-5).

Remove the oil pressure switch diode from the wire harness.

Check for continuity between the diode terminals. When there is continuity, a small resistance value will register.

If there is continuity in one direction, the diode is normal.

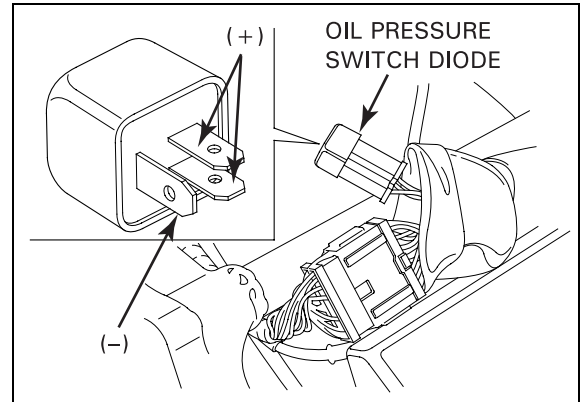

**FRONT TURN SIGNAL LIGHT**

**BULB REPLACEMENT**

Remove the screw and mirror from the rearview mirror housing by releasing the two tabs.

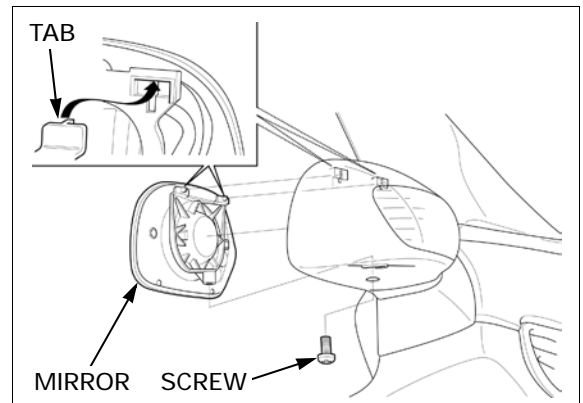

Remove the bulb socket from the turn signal light by turning it counterclockwise.

Pull the bulb out of the socket and replace it with a new one.

Install the removed parts in the reverse order of removal.

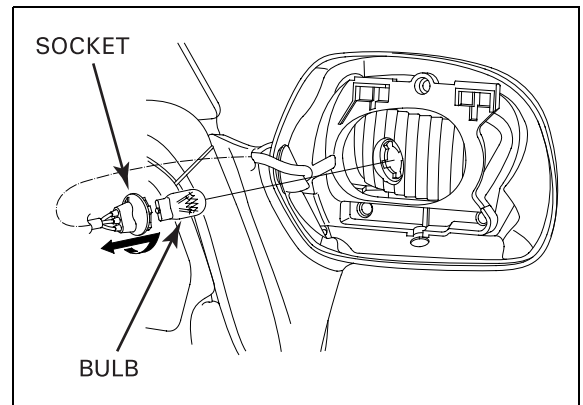

**REPLACEMENT**

Remove the rearview mirror cover (page 2-7).

Disconnect the turn signal light connector. Remove the mirror from the mirror housing. Remove the three screws, base cover and turn signal light assembly.

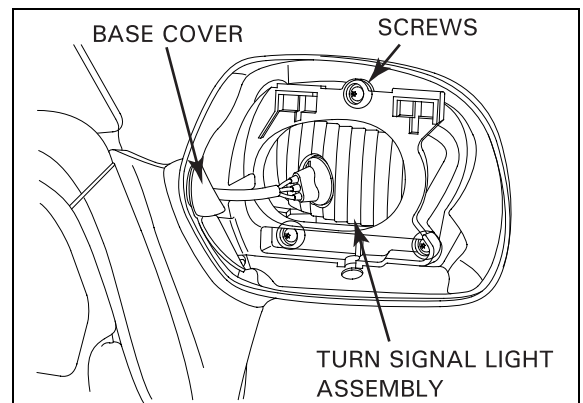

## SADDLEBAG COMBINATION LIGHT

### BULB REPLACEMENT

Open the saddlebag lid.

Remove the three nuts and the combination light from the saddlebag.

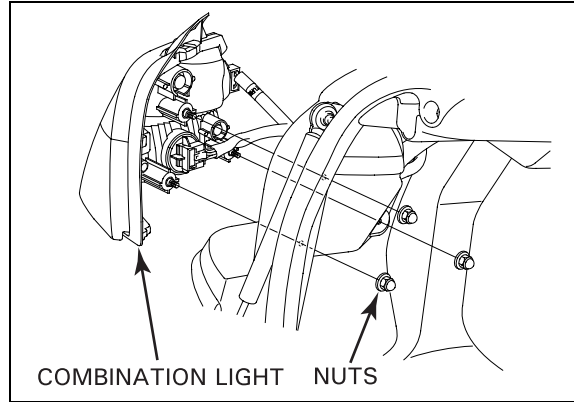

### REAR TURN SIGNAL LIGHT

Remove the bulb socket from the combination light by turning it counterclockwise. Pull the turn signal light bulb out of the socket and replace it with a new one.

Install the removed parts in the reverse order of removal.

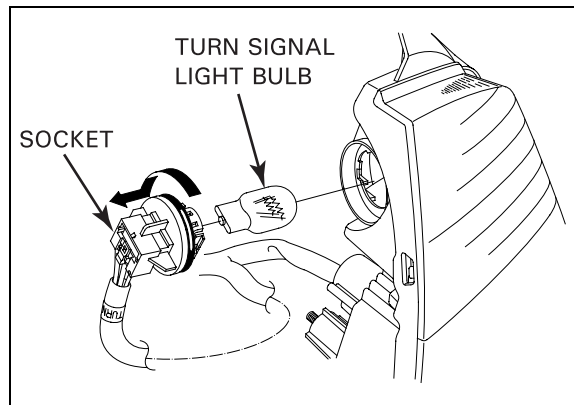

### BRAKE/TAILLIGHT

Remove the bulb socket from the combination light by turning it counterclockwise. Pull the brake/taillight bulb out of the socket and replace it with a new one.

Install the removed parts in the reverse order of removal.

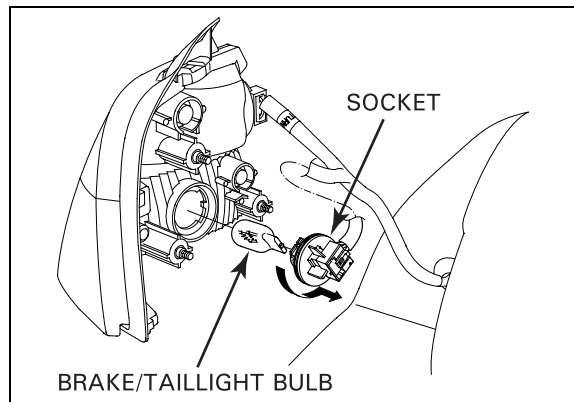



## TRUNK BRAKE/TAILLIGHT

### BULB REPLACEMENT

Open the trunk lid.

Remove the three nuts and the brake/taillight from the trunk.

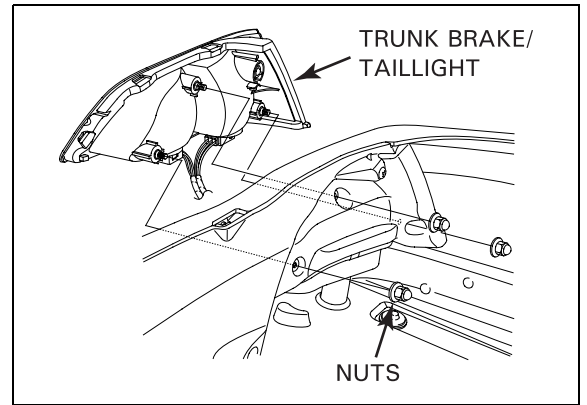

Remove the bulb socket from the brake/taillight by turning it counterclockwise.

Pull the bulb out of the socket and replace it with a new one.

Install the removed parts in the reverse order of removal.

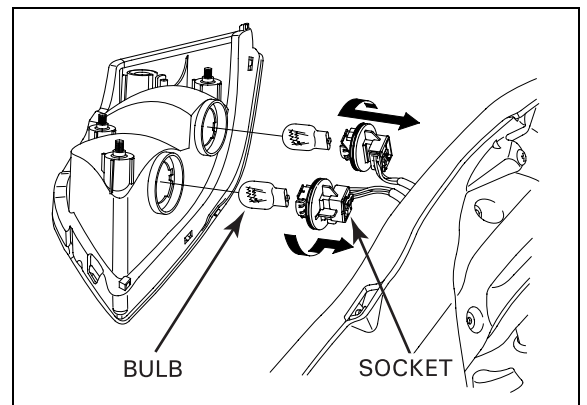

## LICENSE LIGHT

### BULB REPLACEMENT

Remove the two screws and license light lens.

Pull the bulb out of the socket and replace it with a new one.

Install the license light lens and tighten the two screws.

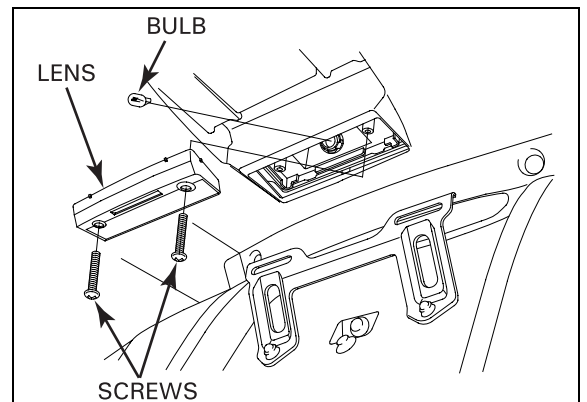

## RELAY BOX

### RELAY INSPECTION

Remove the relay blocks (page 20-12).

The fourteen 4-terminal relays are the same parts and the six 5-terminal relays are the same parts. Check the relay function by exchanging it with the other good one.

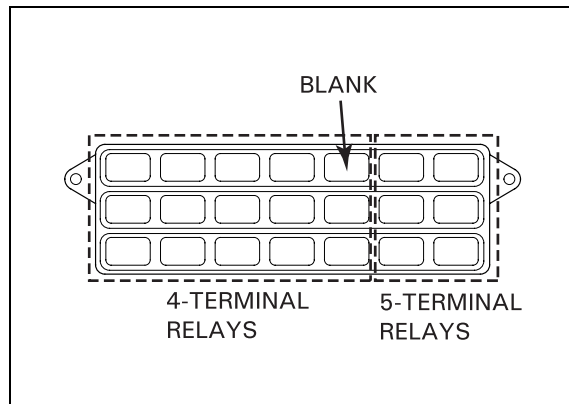

### 4-TERMINAL RELAY CHECK

Check for continuity between the No. 1 and No. 2 terminals.

Connect the fully charged 12-V battery (+) terminal to the relay No. 3 terminal and the (-) terminal to the No. 4 terminal.

- There should be continuity while the battery is connected.
- There should be no continuity when the battery is disconnected.

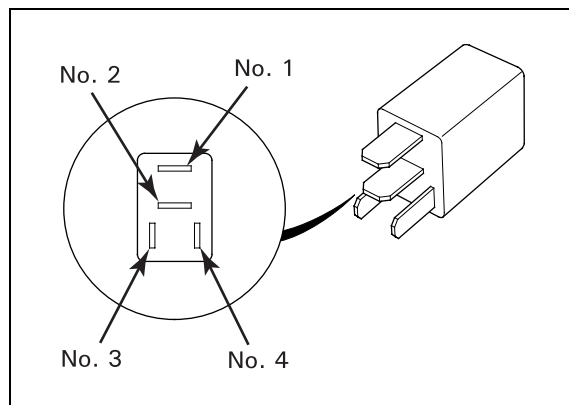

### 5-TERMINAL RELAY CHECK

Check for continuity between the No. 1 and No. 2 terminals, and between No. 1 and No. 4 terminals.

Connect the fully charged 12-V battery (+) terminal to the relay No. 3 terminal and the (-) terminal to the No. 5 terminal.

- There should be continuity between the No. 1 and No. 2 terminals while the battery is connected.
- There should be continuity between the No. 1 and No. 4 terminals when the battery is disconnected.

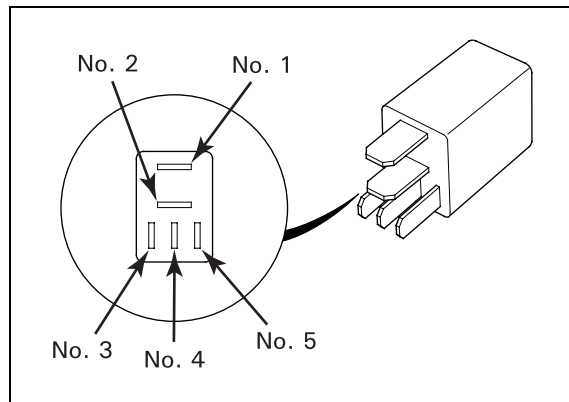

# COMBINATION METER

## REMOVAL/INSTALLATION

Remove the front fairing (page 2-10).

Remove the three combination meter mounting nuts.

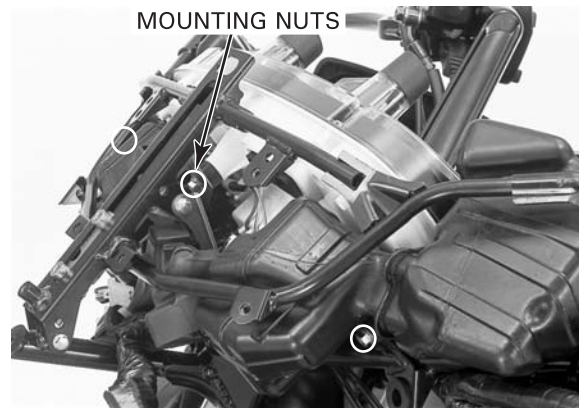

Remove the connector boots from the combination meter.

Disconnect the 20P black, 16P black, 20P blue and 3P white connectors and remove the combination meter from the stay.

Install the combination meter in the reverse order of removal.

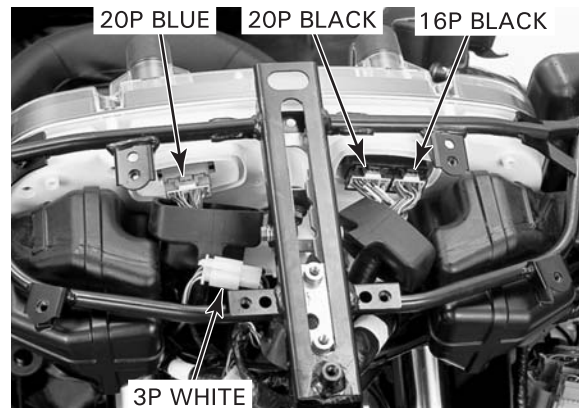

## POWER/GROUND LINE INSPECTION

Remove the combination meter (page 20-17).  
Check the following at the wire harness side connector terminals:

### POWER SOURCE LINE

Measure the voltage between the Brown/white wire terminal (+) of the 20P blue connector and ground (-).  
There should be battery voltage with the ignition switch turned to "ON."

If there is no voltage, check for:

- open circuit in the Brown/white wire between the combination meter and TAIL relay
- TAIL relay (page 20-16)
- loose or poor contact of related connectors

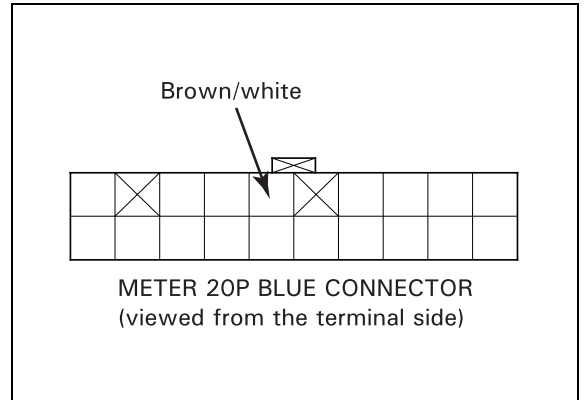

## LIGHTS/METERS/SWITCHES

### ACCESSORY POWER LINE

Measure the voltage between the Light green/black wire terminal (+) of the 20P blue connector and ground (-).

There should be battery voltage with the ignition switch turned to "ON" or "ACC."

If there is no voltage, check for:

- open circuit in the Light green/black wire between the combination meter and ACC relay
- ACC relay (page 20-16)
- loose or poor contact of related connectors

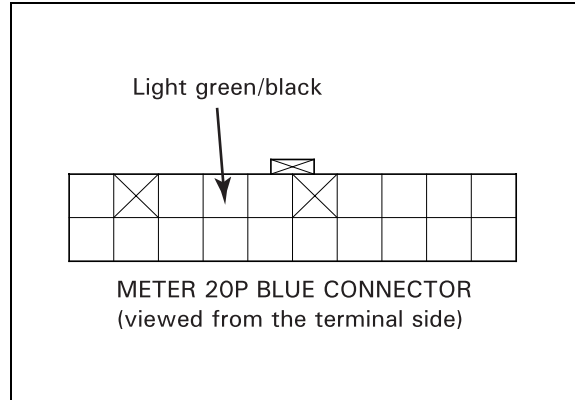

### BACK-UP POWER LINE

Measure the voltage between the Red/yellow wire terminal (+) of the 20P blue connector and ground (-).

There should be battery voltage at all times.

If there is no voltage, check for:

- open circuit in the Red/yellow wire between the combination meter and fuse box (No. 22 fuse)
- blown No. 22 fuse
- loose or poor contact of related connectors

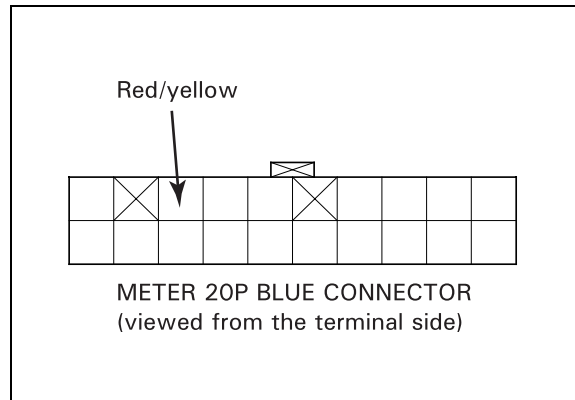

### GROUND LINE

Check for continuity between the Green wire terminal of the 20P black connector and ground. There should be continuity at all times.

If there is no continuity, check for open circuit in the Green wire between the combination meter and ground terminal.

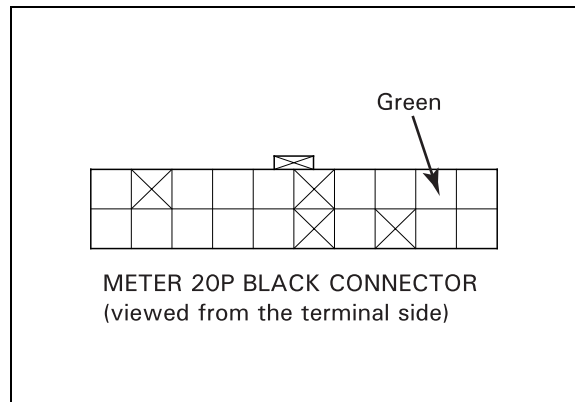

### SENSOR GROUND LINE

Check for continuity between the Green wire terminal of the 20P blue connector and ground. There should be continuity at all times.

If there is no continuity, check for open circuit in the Green wire between the combination meter and ground terminal.

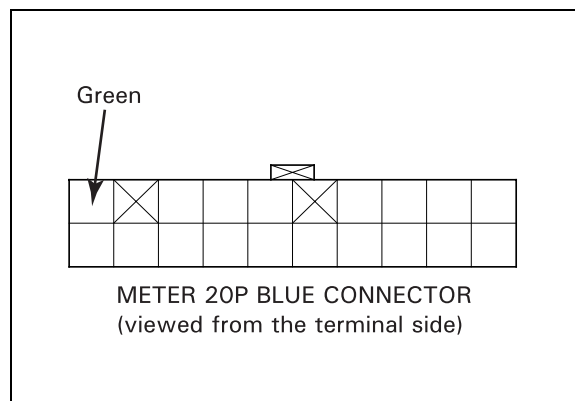

## DISASSEMBLY

Remove the six tapping screws, meter lens and visor.

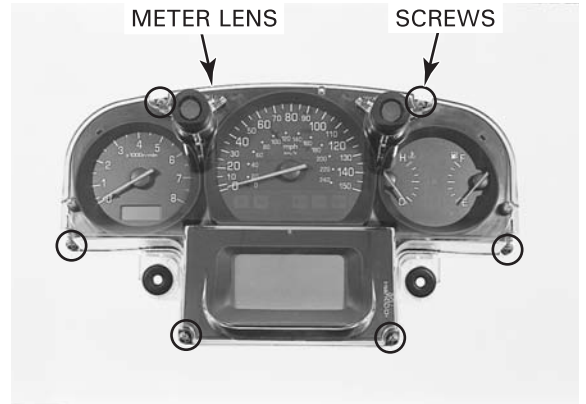

Remove the four tapping screws, disconnect the connector and remove the LCD assembly.

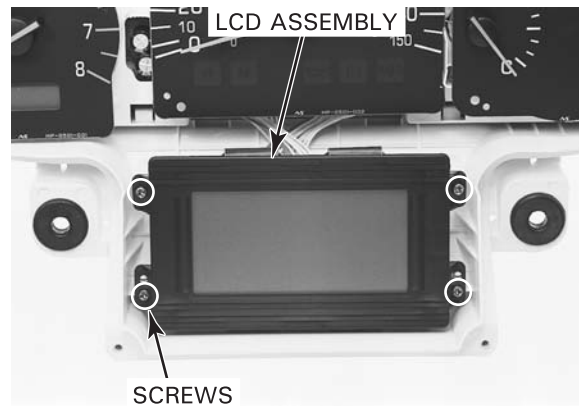

Remove the eight tapping screws and remove the meter/gauge assembly from the lower case.

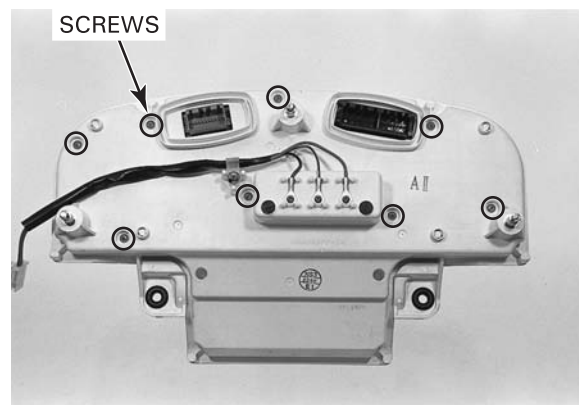

Remove the three terminal screws and turn signal relay circuit board.  
Remove the tapping screw, wire clamp and turn signal relay wire.

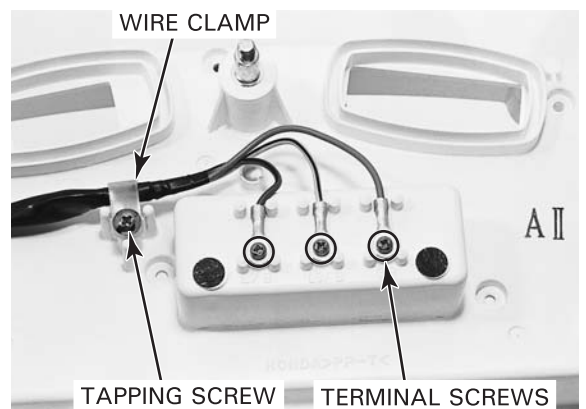

## LIGHTS/METERS/SWITCHES

### ASSEMBLY

Assemble the combination meter in the reverse order of disassembly.

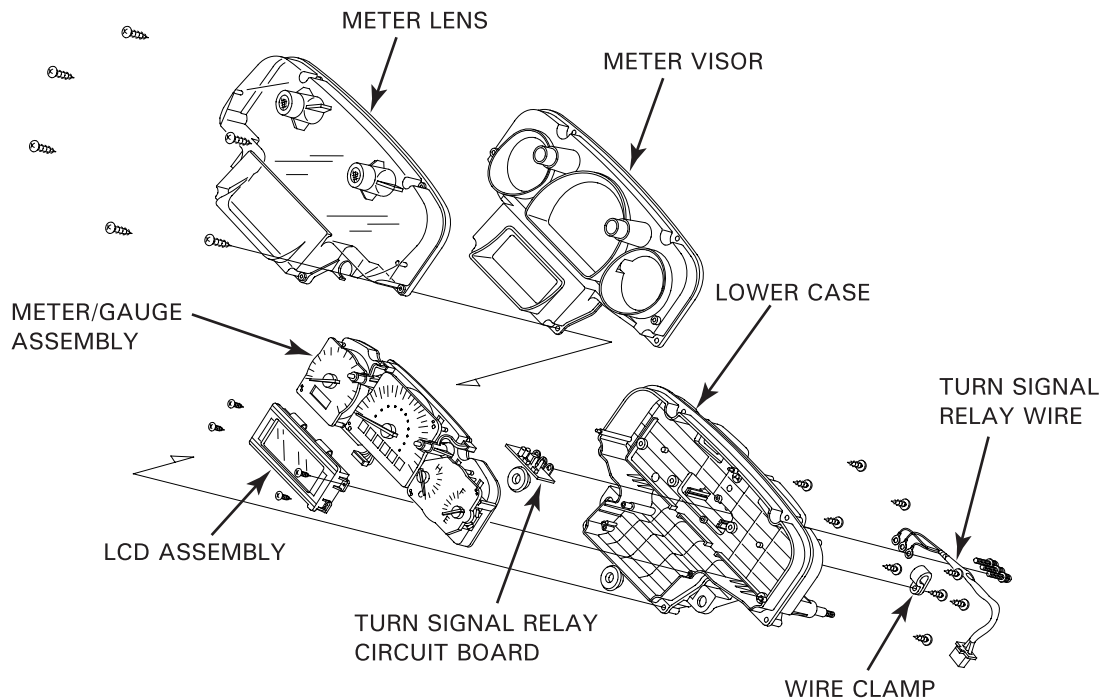

## SPEEDOMETER

### INSPECTION

**Speedometer does not operate**

1. Check that the tachometer, coolant temperature gauge and fuel gauge operate properly.
  - If they do not function, check the power source line and sensor ground line (page 20-17).
  - If they function properly, go to step 2.
2. Check that the engine control module (ECM) stores failure code 11 (page 5-16).
  - If the ECM stores failure code 11, perform the troubleshooting on page 5-28.
  - If the ECM does not store failure codes, go to step 3.

3. Remove the combination meter (page 20-17). Place the motorcycle on its center stand, shift the transmission into neutral and turn the ignition switch to "ON."

Measure the voltage between the White/black (+) and Green (-) wire terminals of the combination meter 20P black connector.

There should be 0 V to 5 V pulse voltage while slowly turning the rear wheel by hand.

- If the pulse voltage appears, replace the meter/gauge assembly (page 20-19).
- If the pulse voltage does not appear, check for:
  - open circuit in the White/black wire between the combination meter and speed sensor
  - loose or poor contact in the related connectors

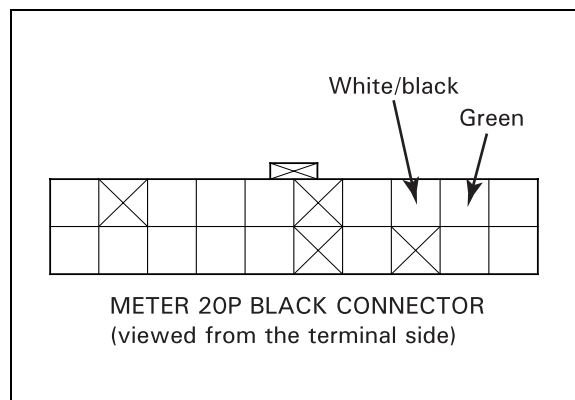



# TACHOMETER

## INSPECTION

### Tachometer does not operate

1. Check that the speedometer, coolant temperature gauge and fuel gauge operate properly.
  - If they do not function, check the power source line and sensor ground line (page 20-17).
  - If they function properly, go to step 2.
2. Remove the combination meter (page 20-17). Connect the peak voltage tester or adaptor probes to the Yellow/green (+) and Green (-) wire terminals of the combination meter 20P black connector.

### TOOLS:

**Peak voltage tester (U.S.A. only) or  
Peak voltage adaptor 07HGJ-0020100  
with commercially available digital multimeter  
(impedance 10 MΩ/DCV minimum)**

Start the engine and measure the tachometer signal peak voltage.

### PEAK VOLTAGE: 10.5 V minimum

- If the measured value is more than 10.5 V, replace the meter/gauge assembly (page 20-19).
  - If the measured value is less than 10.5 V, replace the engine control module (ECM).
  - If there is no voltage, go to step 3.
3. Remove the top shelter (page 2-12). Disconnect the engine control module (ECM) 22P gray connector.

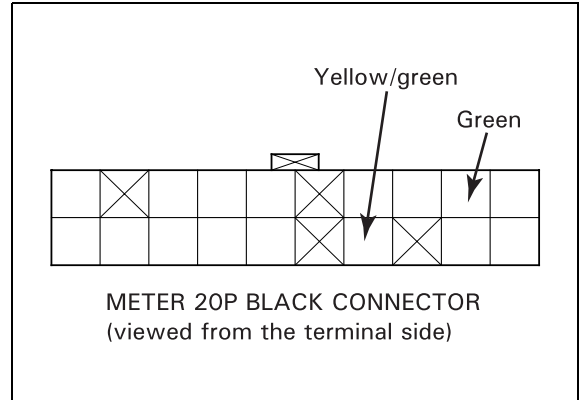

4. Check the Yellow/green wire for open or short circuit as follows:
  - Check for continuity between the combination meter and ECM connectors. There should be continuity.
  - Check for continuity to ground. There should be no continuity.
  - If the Yellow/green wire is OK, replace the ECM.

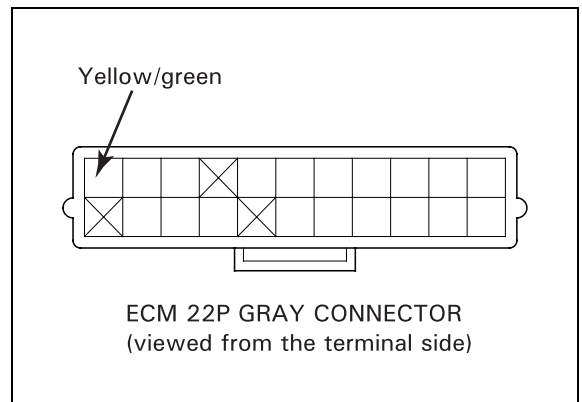

## COOLANT TEMPERATURE GAUGE/ ECT SENSOR

### SYSTEM INSPECTION

1. Check that the tachometer, speedometer and fuel gauge operate properly.
  - If they do not function, check the power source line and sensor ground line (page 20-17).
  - If they function properly, go to step 2.
2. Remove the left radiator stay (page 5-71).

Turn the ignition switch to "OFF" and disconnect the ECT sensor 3P connector.

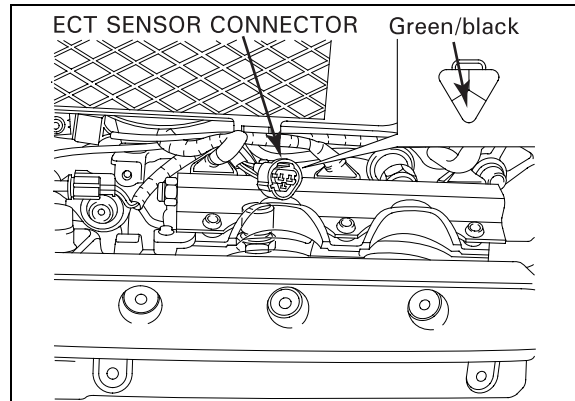

3. Ground the Green/black wire terminal of the ECT sensor connector with a jumper wire.

Turn the ignition switch to "ON" and check the coolant temperature gauge.

The gauge needle should move to "H."

  - If the needle moves, check the ECT sensor.
  - If the needle does not move, go to step 4.

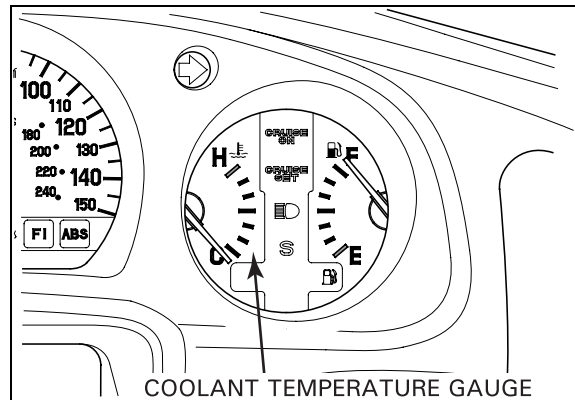

4. Remove the combination meter (page 20-17).

Check the Green/black wire for continuity between the combination meter 20P blue connector and ECT sensor connector.

There should be continuity.

  - If there is continuity, replace the meter/gauge assembly (page 20-19).

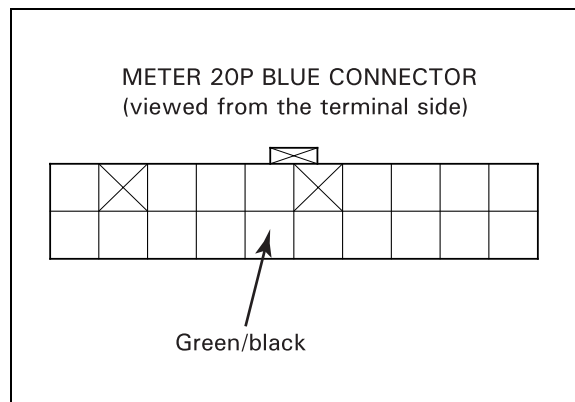

**ECT SENSOR INSPECTION**

Remove both radiators (page 6-8).

Remove the twelve intake manifold bolts and raise the manifold to access the ECT sensor.

Disconnect the ECT sensor connector.  
Remove the ECT sensor and sealing washer from the left cylinder head.

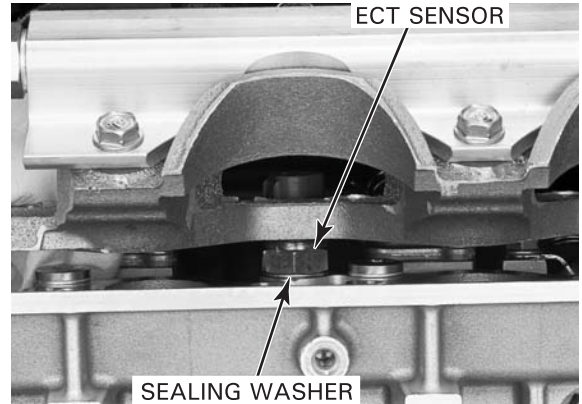

*Keep all flammable materials away from the electric heating element. Wear protective clothing, insulated gloves and eye protection.*

Suspend the ECT sensor in a pan of coolant (1:1 mixture) on an electric heating element and measure the resistance between the thermosensor terminal and body as the coolant heats up.

**NOTE:**

- Soak the ECT sensor in coolant up to its threads with at least 40 mm (1.57 in) from the bottom of the pan to the bottom of the sensor.
- Keep the temperature constant for 3 minutes before testing. A sudden change of temperature will result in incorrect readings. Do not let the thermometer or ECT sensor touch the pan.

Temperature	80° C (176° F)	120° C (248° F)
Resistance	47 - 57	14 - 18

Replace the ECT sensor if it is out of specifications by more than 10% at any temperature listed.

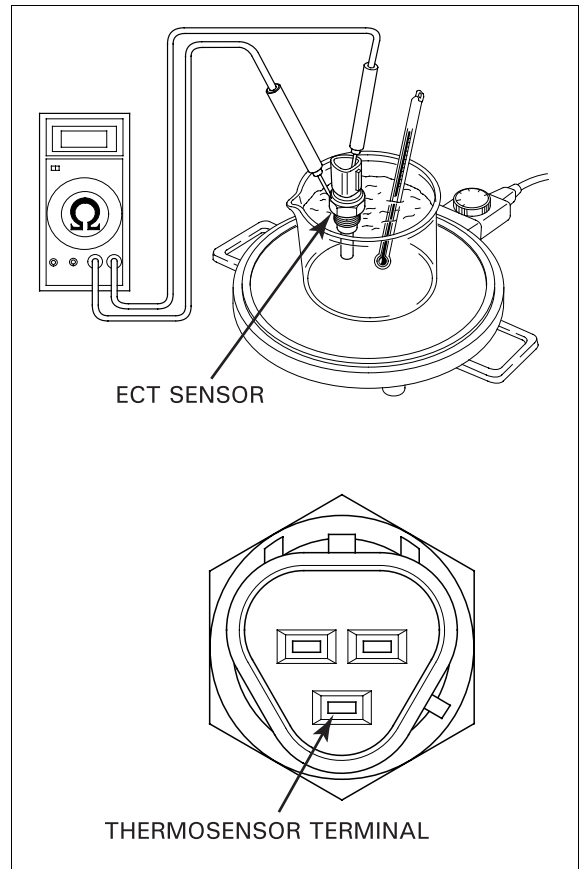

Install the ECT sensor with a new sealing washer and tighten it.

**TORQUE: 25 N·m (2.5 kgf·m, 18 lbf·ft)**

Connect the ECT sensor connector.

Install the removed parts.

Fill and bleed the cooling system (page 6-6).

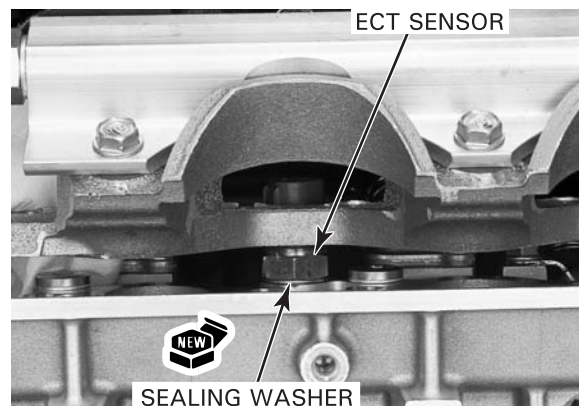

# FUEL GAUGE/LOW FUEL INDICATOR

### SYSTEM INSPECTION

1. Check that the tachometer, speedometer and coolant temperature gauge operate properly.
  - If they do not function, check the power source line and sensor ground line (page 20-17).
  - If they function properly, go to step 2.
2. Remove the seat (page 2-5).

With the ignition switch to "OFF" disconnect the fuel level sensor 2P connector.



3. Turn the ignition switch to "ON," and check the low fuel indicator and fuel level gauge. The indicator should come on and the gauge needle should move to "E."

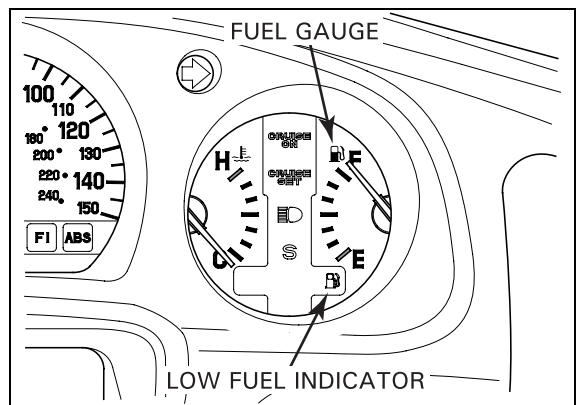

4. Turn the ignition switch to "OFF" and ground the Gray/black wire terminal of the sensor 2P connector with a jumper wire. Turn the ignition switch to "ON," and check the low fuel indicator and fuel level gauge. The indicator should not come on and the gauge needle should move to "F."

- If the indicator and gauge function properly, check the fuel level sensors.
- If one of the indicator or gauge functions properly but the other does not function, replace the meter/gauge assembly (page 20-19).
- If the indicator and gauge do not function, go to step 5.

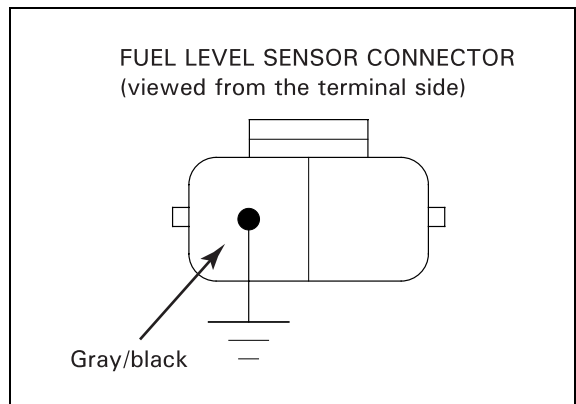

5. Remove the combination meter (page 20-17). Check the Gray/black wire between the combination meter and fuel level sensor connectors.
  - Check for continuity between the combination meter and fuel level sensor connectors. There should be continuity.
  - Check for continuity to ground. There should be no continuity.
  - If the Gray/black wire is OK, replace the meter/gauge assembly (page 20-19).

**FUEL LEVEL SENSOR INSPECTION**

Disconnect the fuel level sensor connector.  
Remove the two bolts and shelter setting stay.



Remove the fuel level sensor retainer by turning it counterclockwise with the special tool.

**TOOL:**  
**Fuel sender/pump wrench 07ZMA-MCAA201 or 07ZMA-MCAA200**

Remove the fuel level sensor and base gasket from the fuel tank.

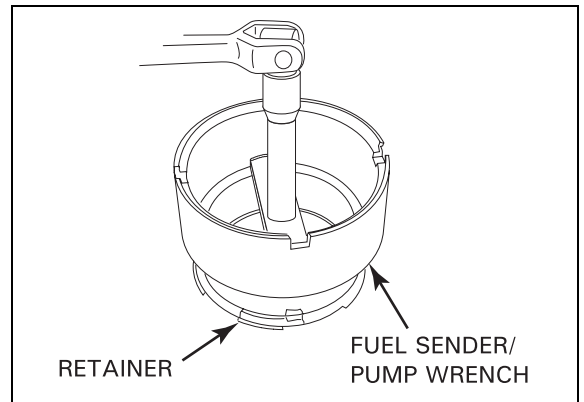

Measure the resistance between the fuel level sensor connector terminals with the float at top (FULL) and bottom (EMPTY) positions.

**RESISTANCE (20° C/68° F):**  
**1.5 – 2.5Ω with the float at FULL position**  
**61.4 – 63.4Ω with the float at EMPTY position**

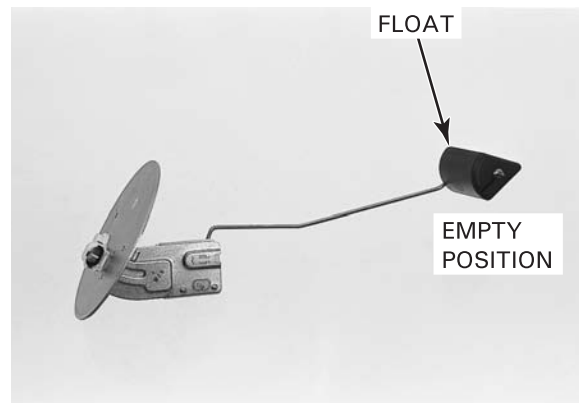

Install a new base gasket.  
Install the fuel level sensor in the fuel tank and align the lugs on the sensor base with grooves in the fuel tank.  
Install the retainer and turn it clockwise with the special tool until it stops.  
Install the removed parts in the reverse order of removal.



## LIGHTS/METERS/SWITCHES

### FUEL PUMP SIDE LEVEL SENSOR

Remove the fuel pump assembly (page 5-60).

Measure the resistance between the fuel level sensor terminals of the fuel pump connector with the float at the top (FULL) and bottom (EMPTY) positions.

#### RESISTANCE (20° C/68° F):

**1.5 – 2.5Ω with the float at FULL position**

**28.6 – 30.6Ω with the float at EMPTY position**

Install the fuel pump assembly (page 5-62).

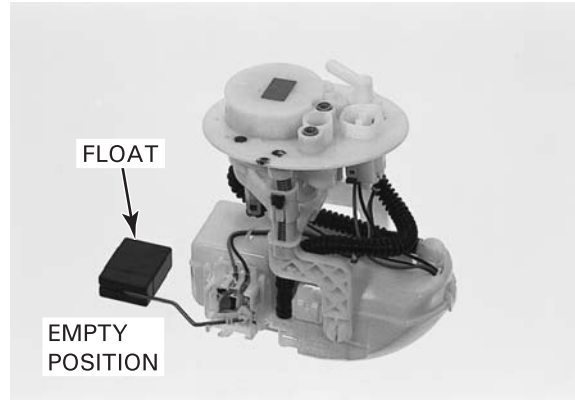

## NEUTRAL INDICATOR

### SYSTEM INSPECTION

1. Shift the transmission into neutral and turn the ignition switch to "ON."

The neutral indicator should come on.

- If the indicator comes on, the system is OK.
- If the indicator does not come on, go to step 2.

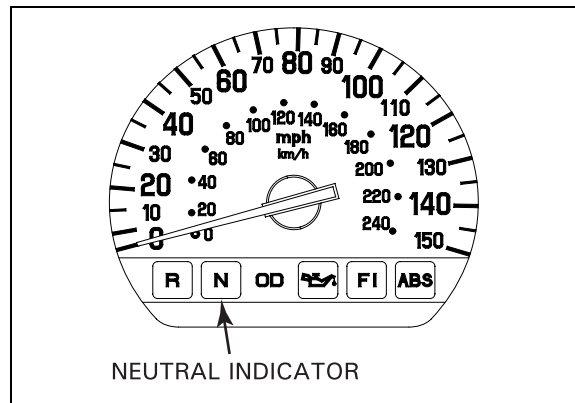

2. Remove the combination meter (page 20-17).

Turn the ignition switch to "ON."

Measure the voltage between the Black/white wire terminal (+) of the combination meter 20P black connector and ground (-).

There should be battery voltage.

- If there is no battery voltage, go to step 3.
- If there is voltage, check for:
  - reverse position switch (page 19-30)
  - reverse shift switch (page 20-35)
  - open circuit in the Black/white, Black/red and Black/brown wires between the combination meter and reverse position switch
  - loose or poor contact of related connectors

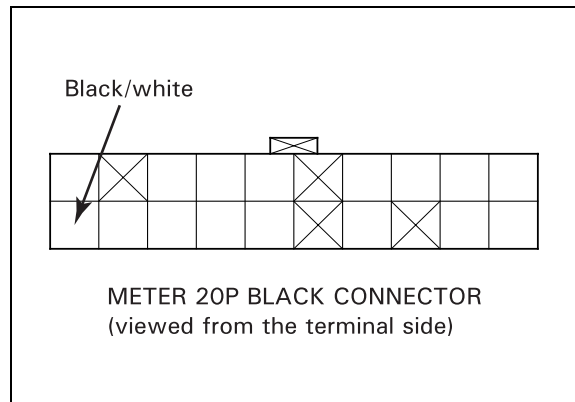

3. Check for continuity between the Light green wire terminal of the combination meter 20P black connector and ground.

There should be continuity.

- If there is continuity, replace the meter/gauge assembly (page 20-19).
- If there is no continuity, check for:
  - faulty gear position switch (page 20-38)
  - faulty diode (D6) (page 19-28)
  - open circuit in the Light green and Light green/red wires between the combination meter and gear position switch

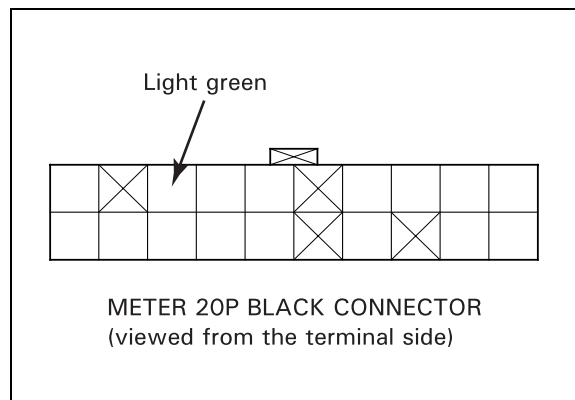



## OIL PRESSURE INDICATOR

### INSPECTION

Remove the left front exhaust pipe protector (page 2-18).

Remove the rubber cap, and disconnect the oil pressure switch wire by removing the terminal screw.

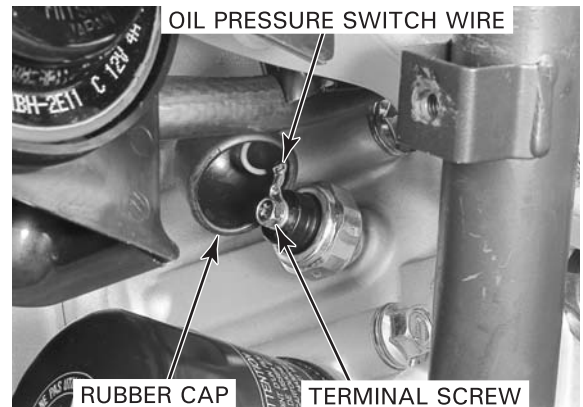

### Indicator does not come on with the ignition switch turned to "ON"

Ground the wire terminal to the engine with a jumper wire.

Turn the ignition switch to "ON" and check the oil pressure indicator.

The indicator should come on.

- If the indicator comes on, replace the oil pressure switch.
- If the indicator does not come on, check for an open circuit in the Blue/red wire between the oil pressure switch and combination meter.

### Indicator stays on while the engine is running

Check for continuity between the oil pressure switch wire terminal and ground.

There should be no continuity.

- If there is continuity, check for short circuit in the Blue/red wire between the oil pressure switch and combination meter
- If there is no continuity, check the oil pressure (page 4-6).  
If the oil pressure is normal, replace the oil pressure switch.

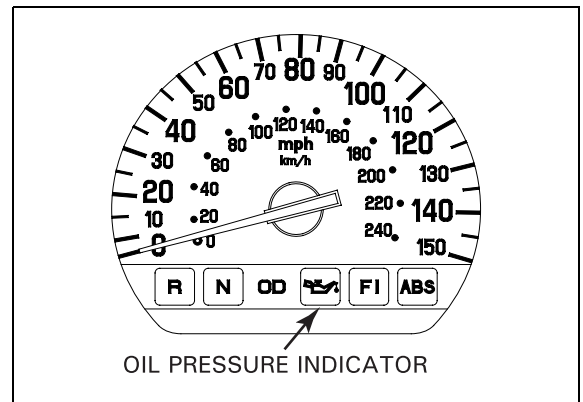

## TURN SIGNAL RELAY

Remove the combination meter (page 20-17).

### POWER INPUT LINE INSPECTION

Turn the ignition switch to "ON" or "ACC."

Measure the voltage between the Light green/black wire terminal (+) of the combination meter 3P connector and ground (-).

There should be battery voltage.

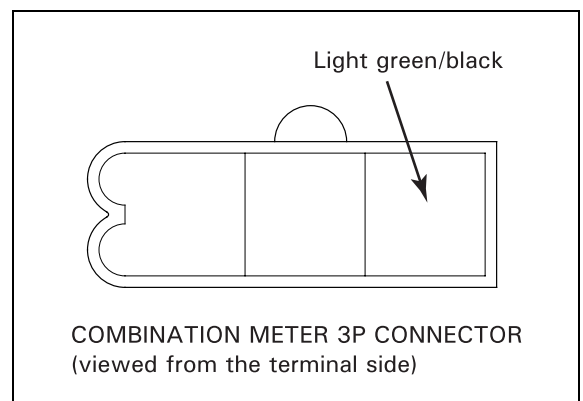

## LIGHTS/METERS/SWITCHES

### FUNCTION CHECK

Turn the ignition switch to "OFF" and connect the combination meter 3P connector.  
Ground the Blue/green wire terminal with a jumper wire.  
Turn the ignition switch to "ON" or "ACC" and operate the turn signal switch.  
The turn signal lights should blink.

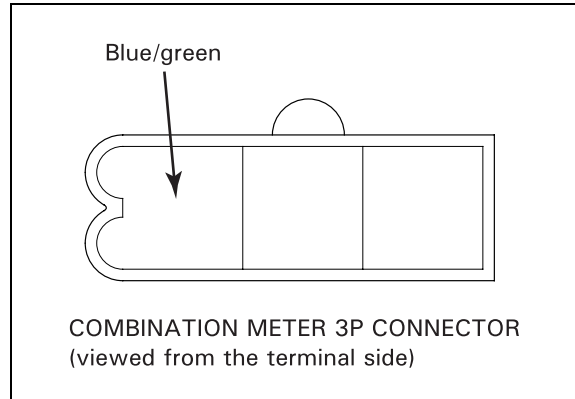

## TURN SIGNAL CANCEL UNIT

### SYSTEM INSPECTION

Remove the front fairing (page 2-10).

Disconnect the 6P gray connector at the right connector holder.  
Check the connector for loose contacts or corroded terminals.  
Check the following at the main wire harness side 6P gray connector.

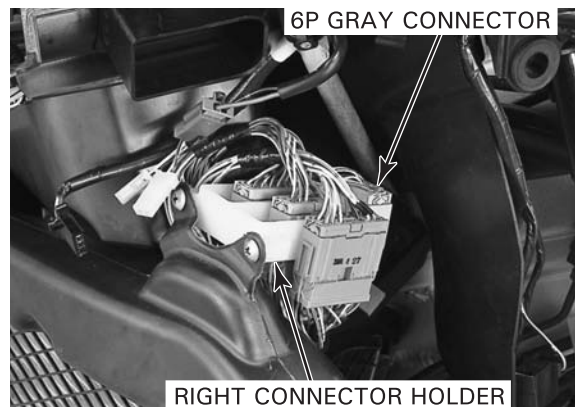

### GROUND LINE

Check for continuity between the Green wire terminal and ground.  
There should be continuity at all times.

- If there is no continuity, check for an open circuit in the Green wire between the 6P gray connector and ground terminal.

### TURN SIGNAL ON SIGNAL LINE

Check for continuity between the Pink wire terminal and ground.  
There should be continuity when the turn signal switch is turned to "←" or "→."

- If there is no continuity, check for an open circuit in the Pink wire between the 6P gray connector and left handlebar switch.

### TURN SIGNAL OFF SIGNAL LINE

Check for continuity between the Light green/white wire terminal and ground.  
There should be continuity when the turn signal switch is pushed.

- If there is no continuity, check for an open circuit in the Light green/white wire between the 6P gray connector and left handlebar switch.

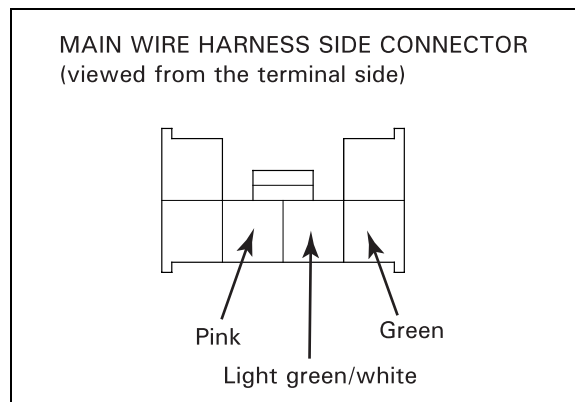

**POWER INPUT LINE**

Measure the voltage between the White/green wire terminal (+) and ground (-). There should be battery voltage with the ignition switch turned to "ON."

- If there is no voltage check the following:
  - open circuit in the White/green wire between the 6P gray connector and HORN TURN relay
  - HORN TURN relay

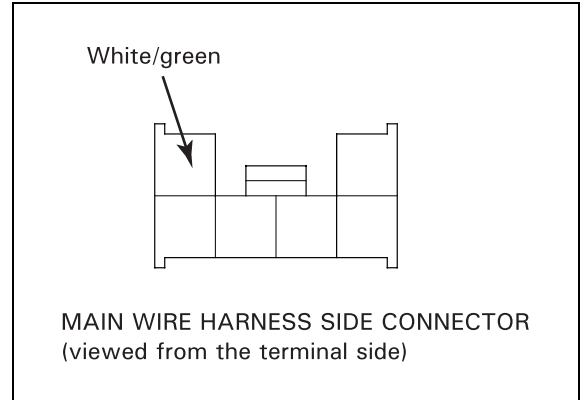

**SPEED PULSE SIGNAL LINE**

Make sure the speedometer operates properly before inspection.

Connect the 6P gray connector. Place the motorcycle on its center stand, shift the transmission into neutral and turn the ignition switch to "ON."

Measure the voltage between the White/black wire terminal (+) and ground (-). There should be 0 V to 5 V pulse voltage while slowly turning the rear wheel by hand.

- If the pulse voltage is not present, check the following:
  - open or short circuit in the White/black wire between the 6P gray connector and combination meter
  - loose or poor contact in related connectors

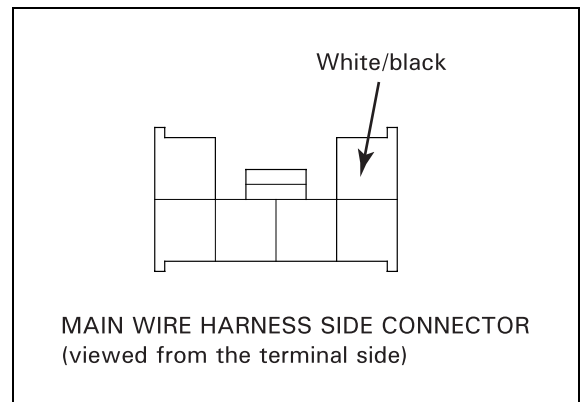

**CANCEL SIGNAL LINE**

Make sure the ground, turn signal on/off signal and power input lines are OK before inspection.

Connect the 6P gray connector and turn the ignition switch to "ON."

Measure the voltage between the Blue/black wire terminal (+) and ground (-). There should be no voltage when the turn signal switch is pushed to "←" or "→." There should be battery voltage when the turn signal switch is pushed.

- If there is battery voltage in both conditions, replace the turn signal cancel unit.
- If there is no voltage in both conditions, check the following:
  - open or short circuit in the Blue/black and Blue/green wires between the 6P gray connector and combination meter 3P connector (turn signal relay)
  - faulty diode (D19) (page 20-32)
  - loose or poor contact in related connectors

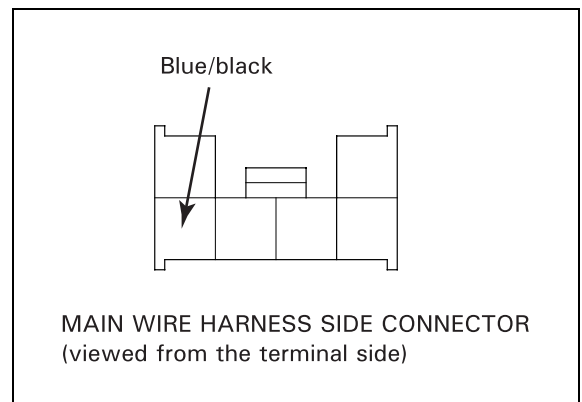

## LIGHTS/METERS/SWITCHES

### ANGLE SENSOR INSPECTION

Check the angle sensor plate for damage or deformation.

Remove the screw attaching the angle sensor plate. Check that the angle sensor rotates smoothly by turning the angle sensor plate.

Install and tighten the screw securely.

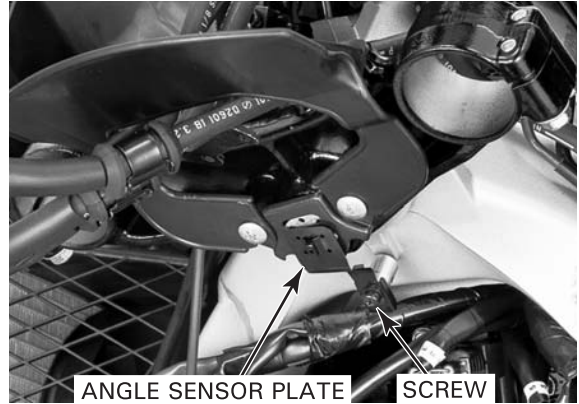

### REMOVAL/INSTALLATION

Remove the meter panel (page 2-7).

Remove the two screws and handlebar center cover.

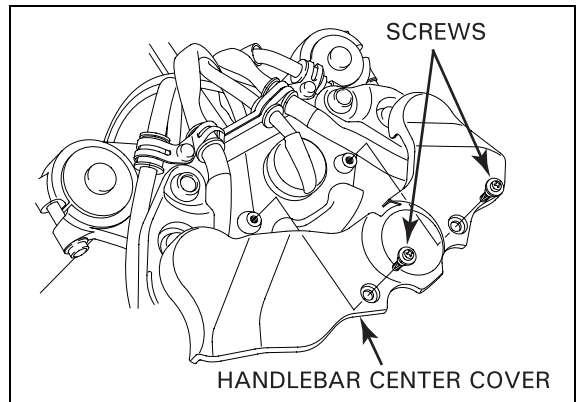

Remove the steering stem nut cap and disconnect the turn signal cancel unit 7P connector.

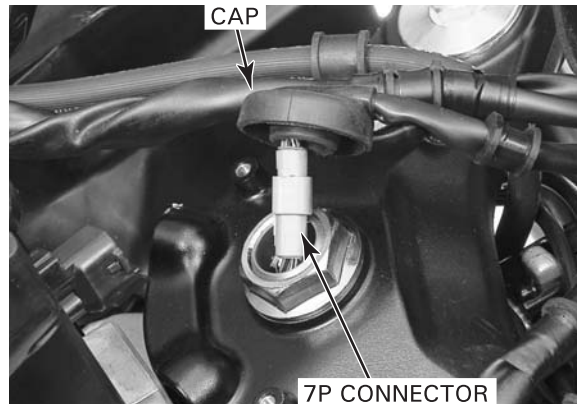

Remove the three screws and turn signal cancel unit from the steering stem.

Installation is in the reverse order of removal.

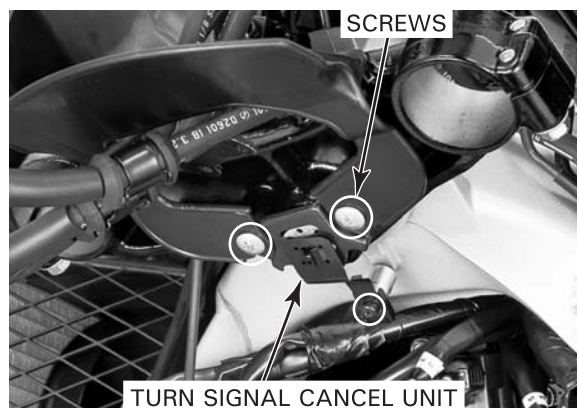

# POSITION LIGHT RELAY

## SYSTEM INSPECTION

**NOTE:**

- The position light relay is same part as the 5-terminal relays in the relay box.

Remove the front fairing (page 2-10).

Remove the position light relay.

Check the following at the wire harness side 5P connector.

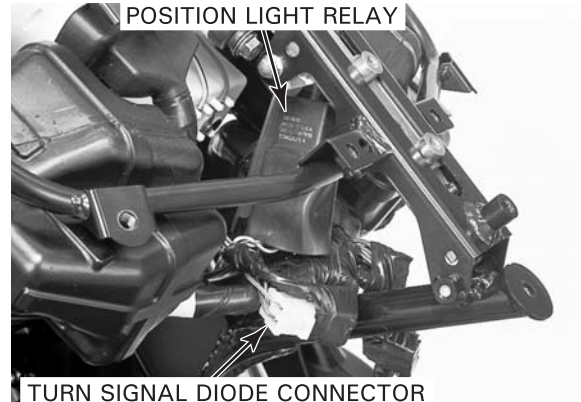

1. Turn the ignition switch to "ON."  
Measure the voltage between the White/green wire terminal (+) of the wire harness side 5P connector and ground (-).  
There should be battery voltage.
  - If there is battery voltage, go to step 2.
  - If there is no voltage, check the following:
    - HORN TURN relay
    - open circuit in the White/green wire
2. Measure the voltage between the Light blue/white wire terminal (+) and ground (-).  
There should be battery voltage and no voltage when the turn signal switch is pushed to "↶."
  - If the measurements are normal, go to step 3.
  - If there is no voltage, check the following:
    - faulty turn signal switch
    - open circuit in the Light blue/white wire
3. Measure the voltage between the Orange/white wire terminal (+) and ground (-).  
There should be battery voltage and no voltage when the turn signal switch is pushed to "↷."
  - If the measurements are normal, go to step 4.
  - If there is no voltage, check the following:
    - faulty turn signal switch
    - open circuit in the Orange/white wire
4. Turn the ignition switch to "OFF" and disconnect the turn signal diode 3P connector.  
Check the Blue/white wire for continuity between the position light relay and turn signal diode connectors.  
There should be continuity.

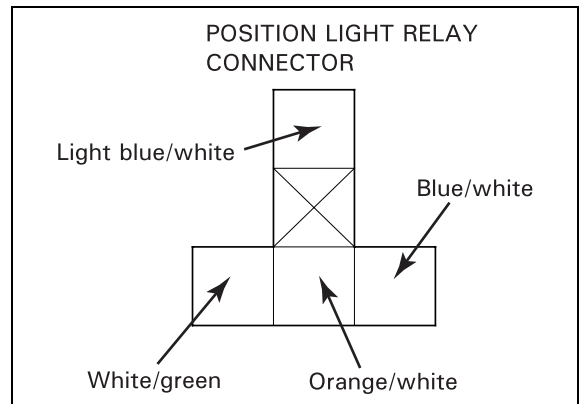

## LIGHTS/METERS/SWITCHES

### TURN SIGNAL DIODE CHECK

Check for continuity between the diode terminals. When there is continuity, a small resistance value will register.

If there is continuity in one direction, the diode is normal.

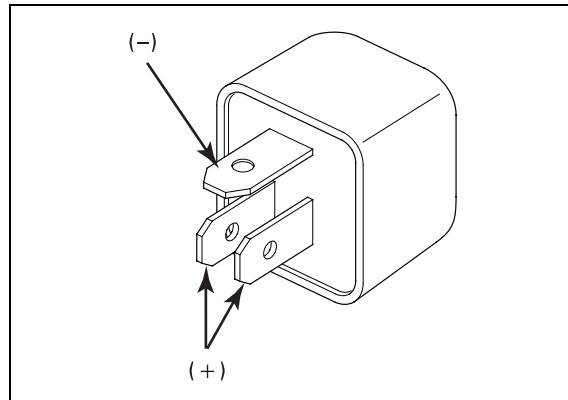

## HAZARD SWITCH

### INSPECTION

Remove the left fairing pocket (page 2-11).

Turn the ignition switch to "OFF" and disconnect the left panel switch assembly 14P gray connector. Check for loose contacts or corroded terminals.

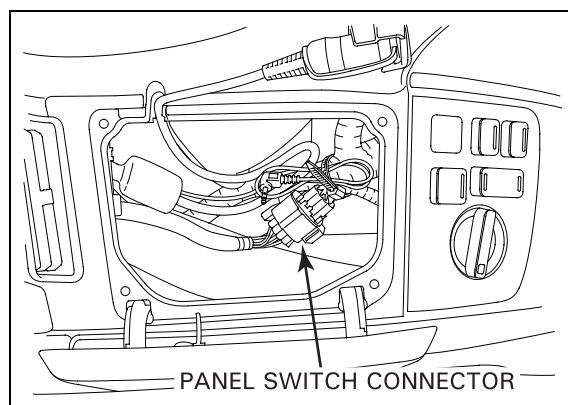

Check for continuity between the switch side connector terminals. Continuity should exist between the color coded wires as shown in the chart.

Color	P/W	Gr	G	Bu/Bl
PUSH (LOCK)	○	○	○	○
FREE				

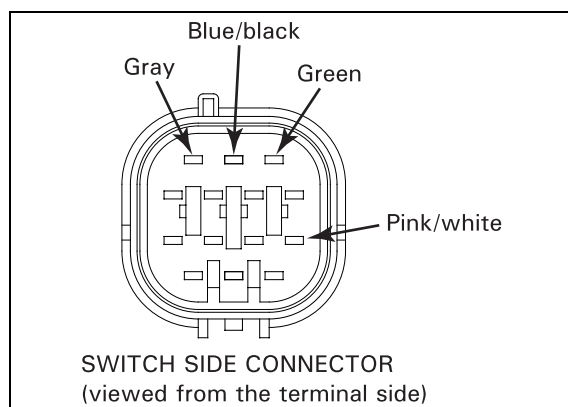

### LEFT PANEL SWITCH REPLACEMENT

Disconnect the left panel switch assembly 14P gray connector (page 20-32).

Remove the left fairing molding (page 2-10).

Remove the screw attaching the switch assembly. Release the three tabs and the switch assembly from the top shelter.

Install new panel switch assembly and removed parts in the reverse order of removal.

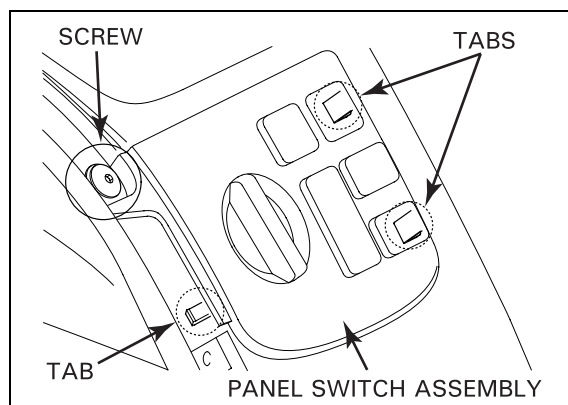



**HAZARD SWITCH DIODE**

Remove the seat (page 2-5).

Remove the hazard switch diode from the wire harness.

Check for continuity between the diode terminals. When there is continuity, a small resistance value will register.

If there is continuity in one direction, the diode is normal.

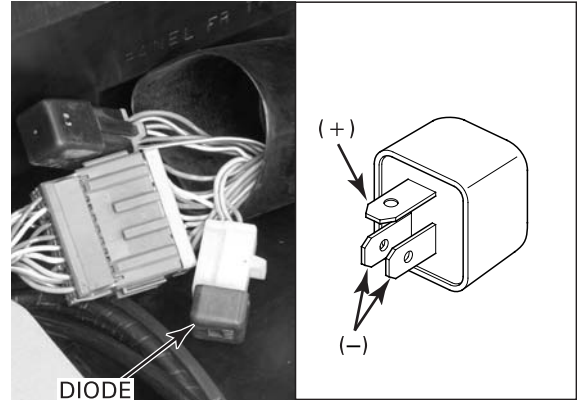

**OPEN AIR TEMPERATURE SENSOR**

**SYSTEM INSPECTION**

Remove the top shelter (page 2-11).

Disconnect the open air temperature sensor 2P white connector.

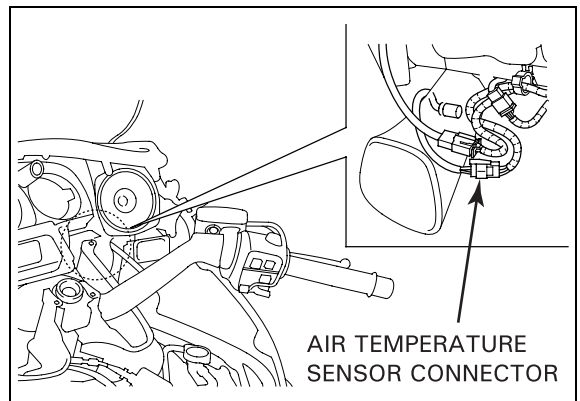

1. Turn the ignition switch to "ON" and measure the voltage between the Yellow/blue (+) and Green/black wire terminal of the wire harness side sensor connector. There should be approximately 5 V.

- If there is approximately 5 V, go to step 2.
- if there is no voltage, check for an open circuit in the Yellow/blue and Green/black wires between the sensor and combination meter connectors.

2. Turn the ignition switch to "OFF" and measure the resistance between the sensor side connector terminals.

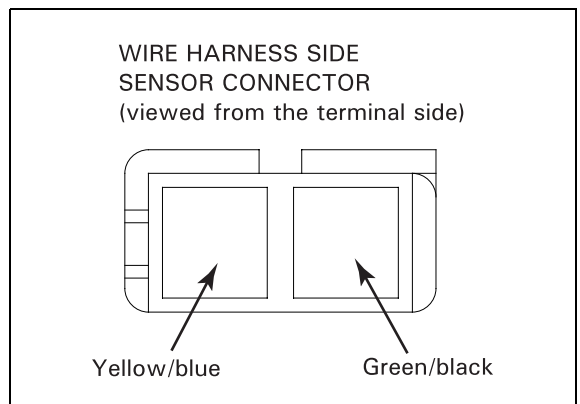

Ambient temperature	Resistance
- 5° C (23° F)	Approx. 21 kΩ
0° C (32° F)	Approx. 16 kΩ
10° C (50° F)	Approx. 10 kΩ
20° C (68° F)	Approx. 6 kΩ
30° C (86° F)	Approx. 4 kΩ
40° C (104° F)	Approx. 2.5 kΩ

## LIGHTS/METERS/SWITCHES

### REMOVAL/INSTALLATION

Remove the front fairing (page 2-10).

Remove the right upper air duct by releasing the grommet from the boss.

Remove the screw and open air temperature sensor from the air duct.

Install the open air temperature sensor in the reverse order of removal.

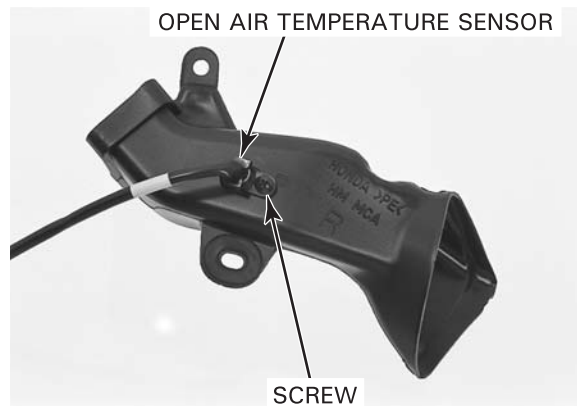
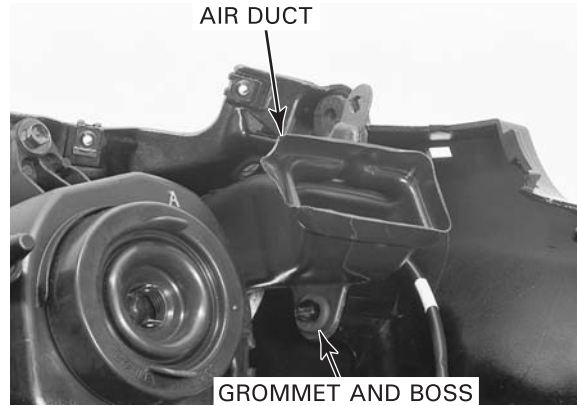

## IGNITION SWITCH

### INSPECTION

Remove the top shelter (page 2-11).

Disconnect the ignition switch 4P white connector.

Check for continuity between the switch side connector terminals in each switch position. Continuity should exist between the color coded wires as shown in the chart.

Color Position	R	Bl	Lg/Bl	Bu/O
LOCK				
OFF				
ON	○	○	○	○
ACC	○		○	

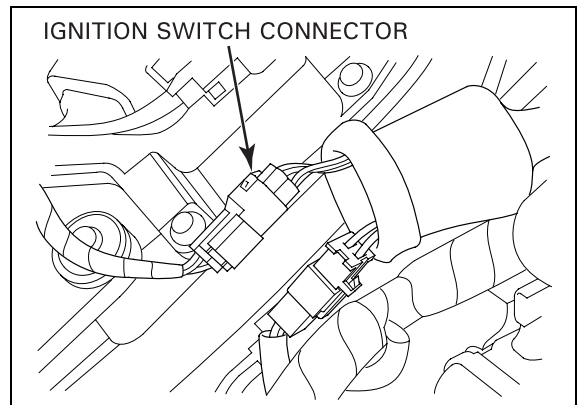

**REMOVAL/INSTALLATION**

Disconnect the ignition switch connector.  
Remove the multi-display control switch 4P connector from the stay on the ignition switch.

Remove the two mounting bolts and the ignition switch.

Install the ignition switch and tighten the mounting bolts.

**TORQUE: 25 N·m (2.5 kgf·m, 18 lbf·ft)**

Install the removed parts in the reverse order of removal.

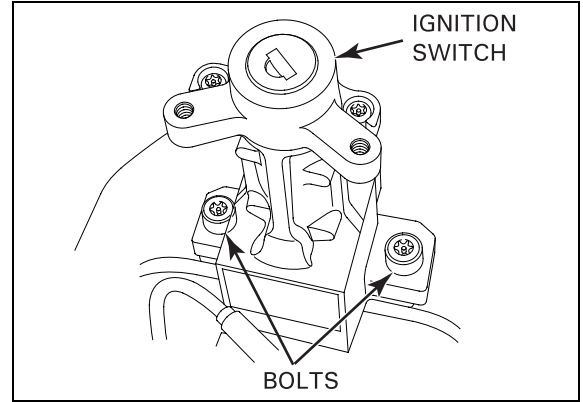

**HANDLEBAR SWITCH**

**INSPECTION**

Remove the front fairing (page 2-10).

Disconnect the following:

'01 - '03:

- right handlebar switch 18P green connector
- left handlebar switch 12P green connector
- left handlebar switch 14P blue connector

After '03:

- right handlebar switch 18P blue connector
- left handlebar switch 12P blue connector
- left handlebar switch 14P gray connector

Check for continuity between the connector terminals in each switch position. Continuity should exist between the color coded wires as shown below.

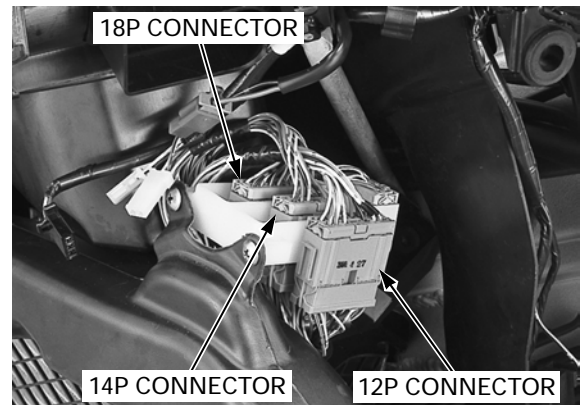

**RIGHT HANDLEBAR SWITCH**

NOTE:

- For cruise control switch inspection, see section 21.

**Starter/reverse switch**

Color \ Position	BI/W	Y/R	Br/W	Bu/W
FREE			○ — ○	
PUSH	○ — ○			

**Engine stop switch**

Color \ Position	W	BI/W
OFF		
RUN	○ — ○	
OFF		

**Reverse shift switch**

Color \ Position	Br	Y/W	BI/Br	BI/R
FREE			○ — ○	
PUSH	○ — ○			

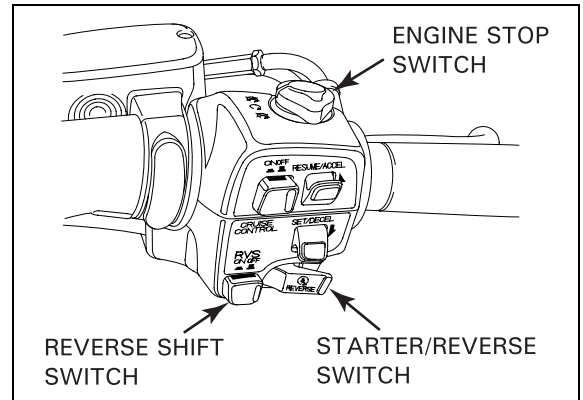

# LIGHTS/METERS/SWITCHES

## LEFT HANDLEBAR SWITCH

NOTE:

- For audio switch inspection, see section 21.

### Dimmer switch

Color Position	Bu/W		Bu
LO			
(N)	○	—	○
HI	○		○

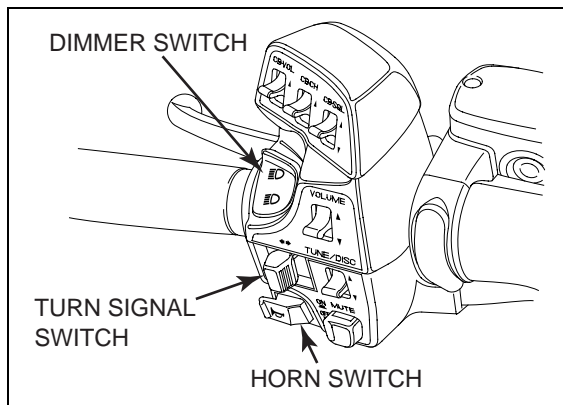

### Horn switch

Color Position	W/G	Lg
FREE		
PUSH	○	○

### Turn signal switch

Color Position	Gr	Lb	O	Br/W	Lb/W	O/W	G	P	G	Lg/W
R	○	○		○	—	○	○	○		
L	○		○	○	○		○	○		
PUSH									○	○

## DISASSEMBLY/ASSEMBLY

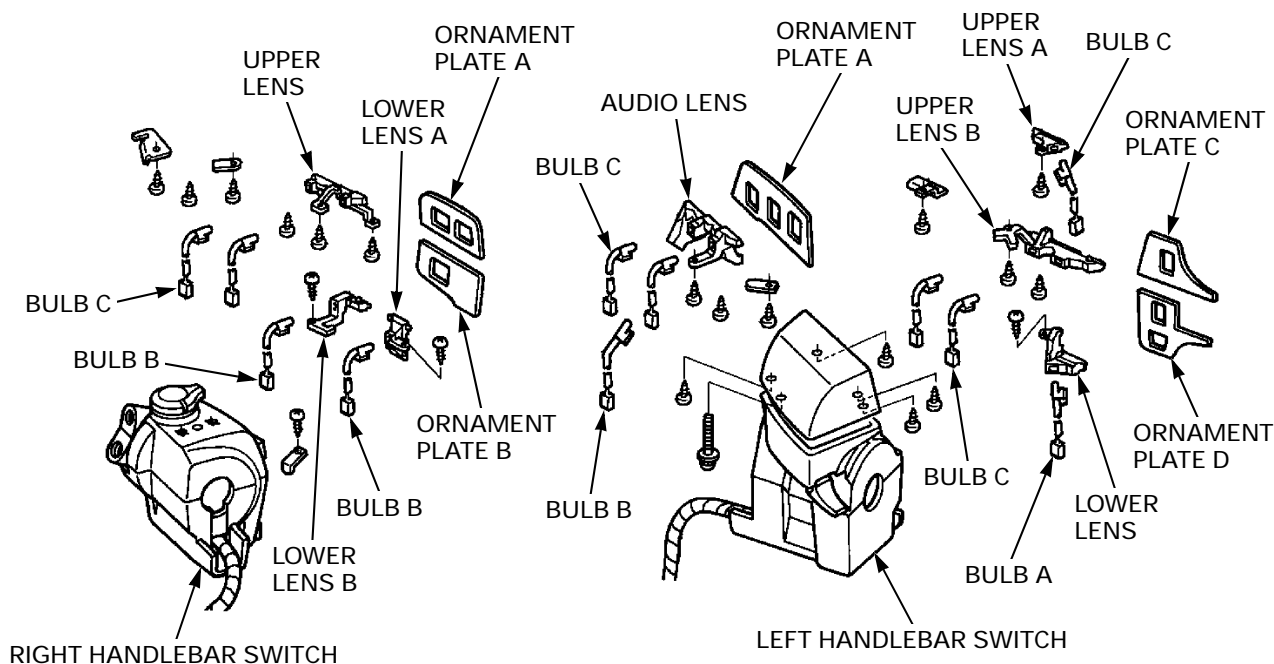

## BRAKE SWITCH

### FRONT

**NOTE:**

- The upper (small) terminals are the brake light switch terminals.

Disconnect the front brake switch connectors and check for continuity between the switch terminals.

There should be continuity with the front brake lever squeezed and no continuity with the lever released.



### REAR

Remove the top shelter (page 2-11).

There should be continuity with the rear brake pedal depressed and no continuity with the pedal released.

Disconnect the rear brake light switch 3P white connector and check for continuity between the switch side connector terminals.

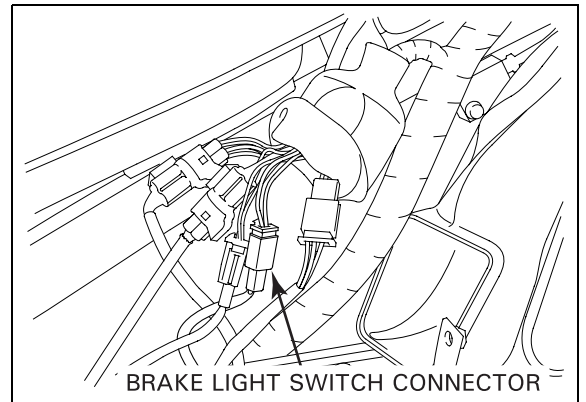

## CLUTCH SWITCH

**NOTE:**

- The upper switch is the clutch switch.

Disconnect the clutch switch wire connectors and check for continuity between the switch terminals.

There should be continuity with the clutch lever squeezed and no continuity with the lever released.



## GEAR POSITION SWITCH

### INSPECTION

Remove the air cleaner housing (page 5-65).  
Disconnect the gear position switch connector.

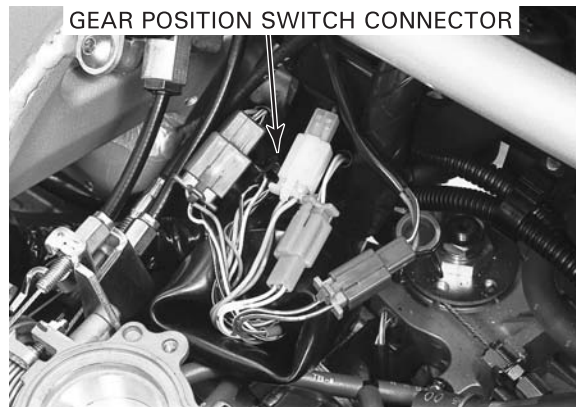

Check for continuity at the switch side connector terminals.  
There should be continuity in each gear position as follows:

<b>GEAR POSITION</b>	<b>CONTINUITY</b>
<b>Neutral</b>	<b>Light green/red to ground</b>
<b>1st</b>	<b>-</b>
<b>2nd</b>	<b>Black/yellow to ground</b>
<b>3rd</b>	<b>White/red to ground</b>
<b>4th</b>	<b>Red/white to ground</b>
<b>Overdrive</b>	<b>Green/orange to ground</b>

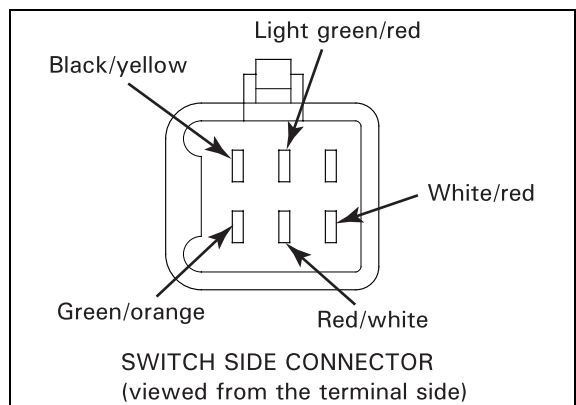

### REPLACEMENT

Remove the air cleaner housing (page 5-65).  
Disconnect the gear position switch connector.  
Remove the gear position switch from the gearshift linkage cover (page 10-8).  
Install a new gear position switch onto the gearshift linkage cover and install the cover (page 10-9).  
Connect the gear position switch connector.  
Install the air cleaner housing (page 5-65).

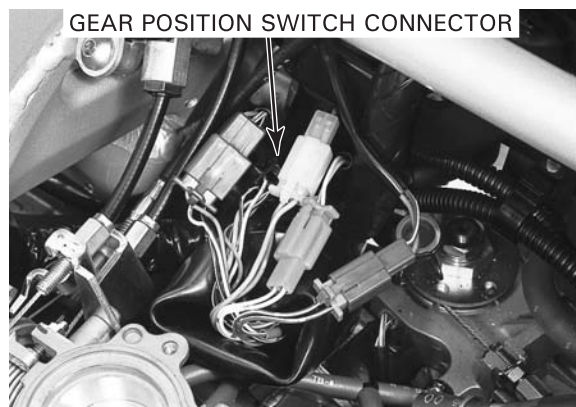



## SIDE STAND SWITCH

### INSPECTION

Remove the left engine side cover (page 2-5).

Disconnect the side stand switch 3P connector. Check for continuity between the switch side connector terminals in each side stand position. There should be continuity as follows:

Position \ Color	G/W	G	Y/Bl
	Extended		○ — ○
Retracted	○ — ○		

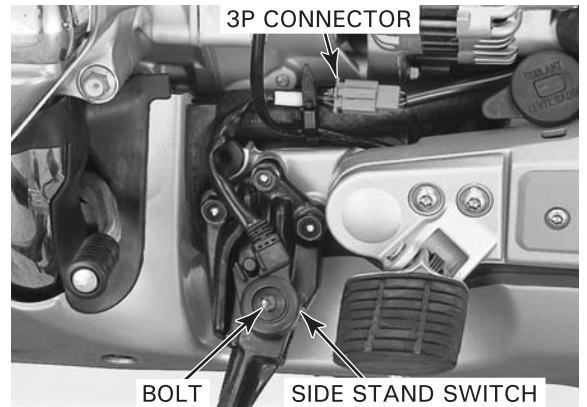

### REPLACEMENT

Remove the left engine side cover (page 2-5).

Disconnect the side stand switch 3P connector.

Remove the side stand switch bolt and the switch.

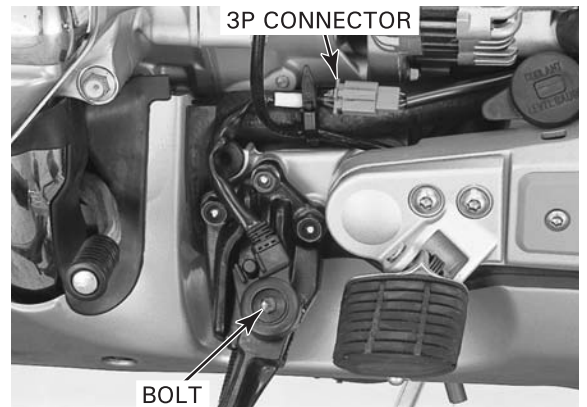

Install a new side stand switch by aligning the switch pin with the hole in the side stand and the switch groove with the bracket pin.

Install the side stand switch bolt and tighten it.

**TORQUE: 10 N·m (1.0 kgf·m, 7 lbf·ft)**

Connect the side stand switch 3P connector.

Install the left engine side cover (page 2-5).

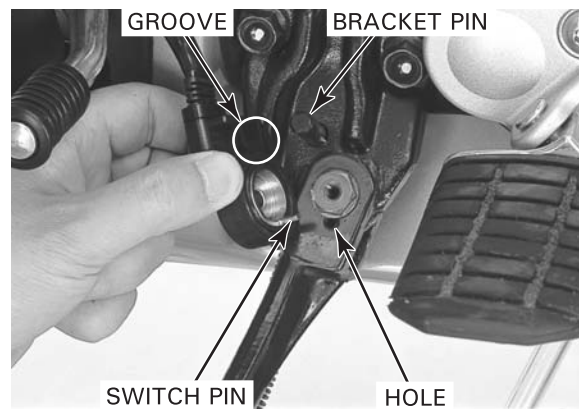

## MULTI-DISPLAY CONTROL SWITCH

### REMOVAL/INSTALLATION

Remove the meter panel (page 2-7).

Remove the two screws and multi-display control switch.

Installation is in the reverse order of removal.

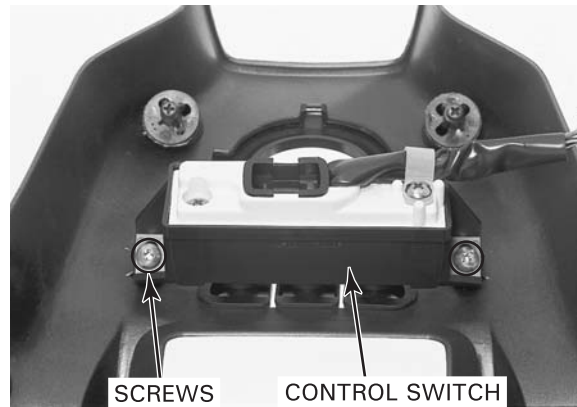

### INSPECTION

Check for continuity between the switch connector terminals.

#### MODE SWITCH

There should be continuity between the Black/yellow and Green/yellow wire terminals when the "MODE" switch is depressed.

#### TRIP SWITCH

There should be continuity between the Brown/yellow and Green/yellow wire terminals when the "TRIP" switch is depressed.

#### DISP SWITCH

There should be continuity between the Blue/yellow and Green/yellow wire terminals when the "DISP" switch is depressed.

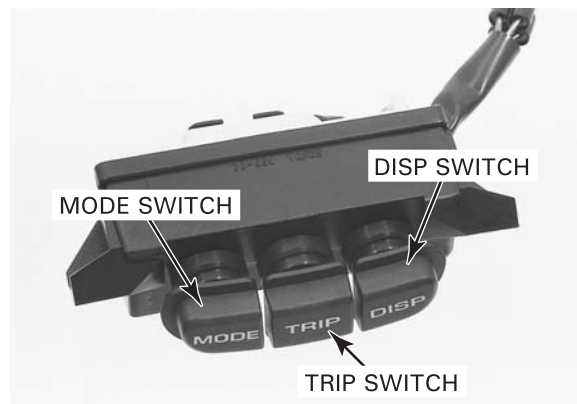

## HORN

Remove the front lower fairing (page 2-6).

Disconnect the wire connectors from the horn. Connect a 12-V battery to the horn terminals.

The horn is normal if it sounds when the 12-V battery is connected across the horn terminals.

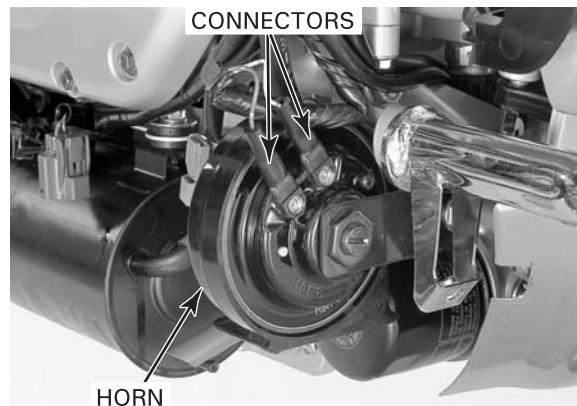

## FAN CONTROL RELAY

### INSPECTION

Check that the engine control module (ECM) stores failure code 7 before inspection (page 5-16).

If the ECM stores failure code 7, perform the troubleshooting on page 5-19.

#### Fan motor does not start

1. Remove the relay blocks (page 20-16).  
Turn the ignition switch to "OFF" and remove the fan control relay.



2. Turn the ignition switch to "ON" and measure the voltage between the Black/blue wire terminal (+) and ground (-).  
There should be battery voltage.

- If there is battery voltage, go to step 3.
- If there is no voltage, check the following:
  - blown No. 7 fuse
  - open circuit in the Black/blue wire

3. Turn the ignition switch to "OFF" and connect the Blue and Black/blue wire terminals with a jumper wire.  
Turn the ignition switch to "ON."  
The cooling fan should start.

- If the cooling fans start, go to step 4.
- If the cooling fans do not start, check the following:
  - faulty cooling fan
  - open circuit in the Blue and Green wires

4. Exchange the fan control relay with a known-good one.  
Start the engine and warm it up and check the cooling fans.

- If the cooling fans start, replace the fan control relay.
- If the cooling fans do not start, check for an open circuit in the Black/red wire between the relay and engine control module.

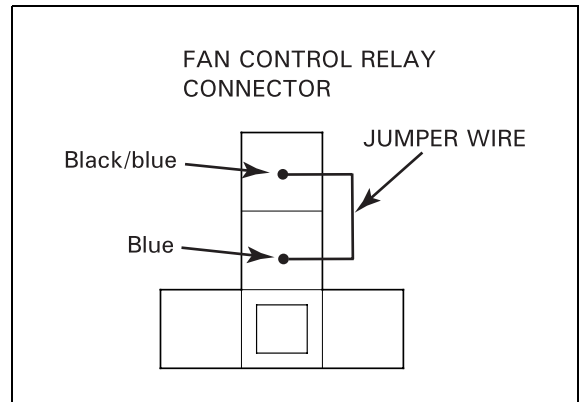

## POWER TRUNK LOCK SYSTEM

**NOTE:**

- The turn signal lights blink twice when the trunk opener unit is unlocked using the transmitter with the ignition switch turned to "OFF" or "LOCK."
- The turn signal lights blink once when the trunk opener unit is locked using the transmitter with the ignition switch turned to "OFF" or "LOCK."
- The horns sound twice and the turn signal lights blink twice when the "CALL" button is pushed for more than 0.5 second.
- The trunk opener unit can be unlocked or locked using the transmitter with the ignition switch turned to "ON" or "ACC," but the turn signal lights do not blink.
- The "POP UP" and "CALL" functions do not work with the ignition switch turned to "ON" or "ACC."
- If any of the lids are open, the trunk opener unit cannot be locked using the transmitter and the turn signal lights blink ten times when the lock button is pushed.
- If the trunk opener unit is unlocked using the transmitter but any of the lids is not opened within 30 seconds, the trunk is locked automatically.

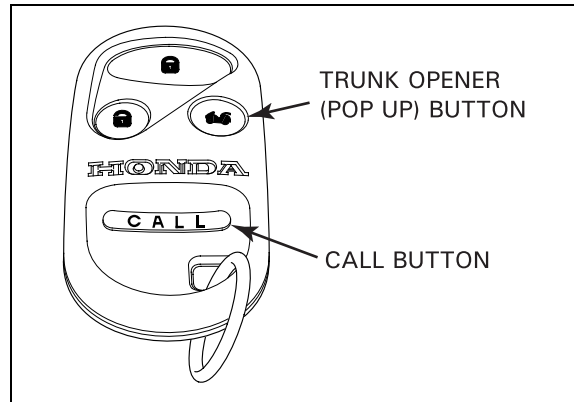

## TRANSMITTER REGISTRATION

**NOTE:**

- The codes of up to three transmitters can be registered into the trunk lock control unit memory. (If a fourth code is stored, the code which was registered first will be erased.)
  - Make sure to keep the timing between 1 and 4 seconds for each action. Too fast or too slow will cause the control unit to lose the stored codes.
1. Turn the ignition switch to "ON." Between 1 and 4 seconds, press the trunk opener button on the transmitter while aiming transmitter at the trunk. Between 1 and 4 seconds, turn the ignition switch to "OFF."
  2. Between 1 and 4 seconds, turn the ignition switch back to "ON." Between 1 and 4 seconds, press the trunk opener button on the transmitter while aiming transmitter at the trunk. Between 1 and 4 seconds, turn the ignition switch to "OFF."
  3. Between 1 and 4 seconds, turn the ignition switch back to "ON." Between 1 and 4 seconds, press the trunk opener button on the transmitter while aiming transmitter at the trunk. Between 1 and 4 seconds, turn the ignition switch to "OFF."
  4. Between 1 and 4 seconds, turn the ignition switch back to "ON." Between 1 and 4 seconds, press the trunk opener button on the transmitter while aiming transmitter at the trunk. Confirm that the turn signal lights blink twice. Leave the ignition switch "ON."
  5. Within 10 seconds, aim the transmitters (up to three) that you want to store codes in at the trunk and press the trunk opener button once on each transmitter. Confirm that the turn signal lights blink twice. Turn the ignition switch to "OFF."

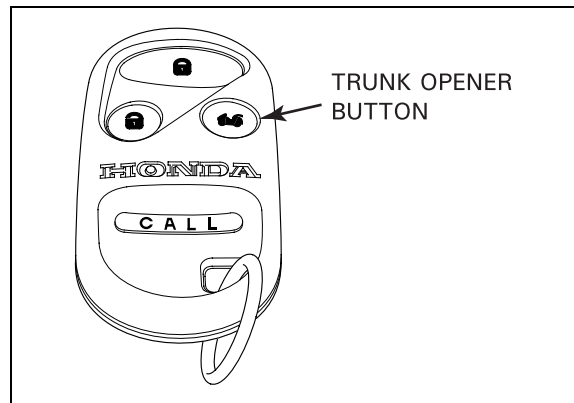

6. Confirm proper operation of each transmitter with the new codes.

## TROUBLESHOOTING

### Power trunk lock system does not function with the transmitter

1. Check for water leakage into the transmitter.
  - If there is water leakage, replace the transmitter.
  - If there is no water leakage, go to step 2.
2. Replace the battery (CR2025) with a new one and check if the system functions with the transmitter.
  - If the system functions properly, the transmitter is OK.
  - If the system does not function, go to step 3.
3. Rewrite the transmitter code (page 20-42) and check if the system functions with the transmitter.
  - If the system functions properly, the transmitter is OK.
  - If the system does not function, go to step 4.
4. Register the good known transmitter and check that the system functions properly.
  - If the system functions properly, replace the transmitter.
  - If the system does not function, go to step 5.
5. Remove the trunk lid inner cover and disconnect the trunk lock control unit 18P white connector (page 20-46). Check for continuity between the Green wire terminal and ground. There should be continuity at all times.
  - If there is continuity, go to step 6.
  - If there is no continuity, check for an open circuit in the Green wire.

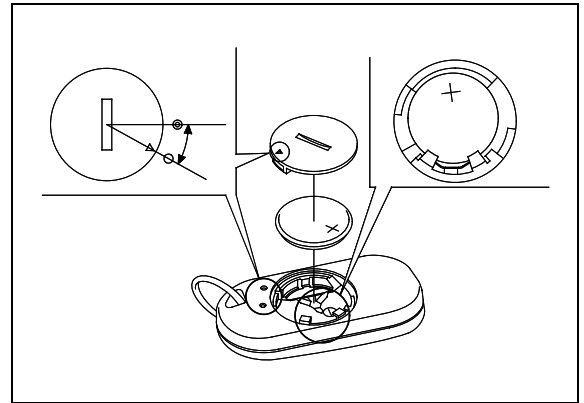

6. Measure the voltage between the Red/yellow wire terminal (+) and ground (-). There should be battery voltage at all times.
  - If there is battery voltage, replace the trunk lock control unit (page 20-46).
  - If there is no voltage, check the following:
    - blown No. 22 fuse.
    - open circuit in the Red/yellow wire.

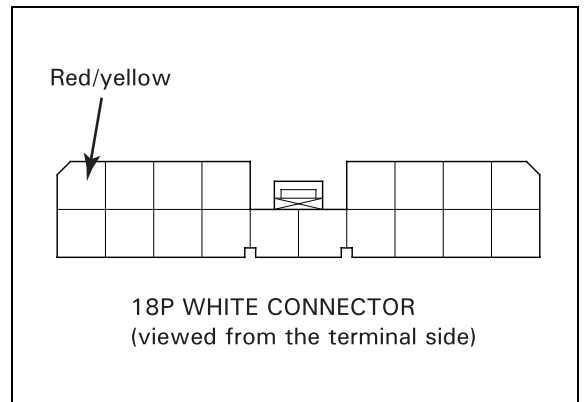
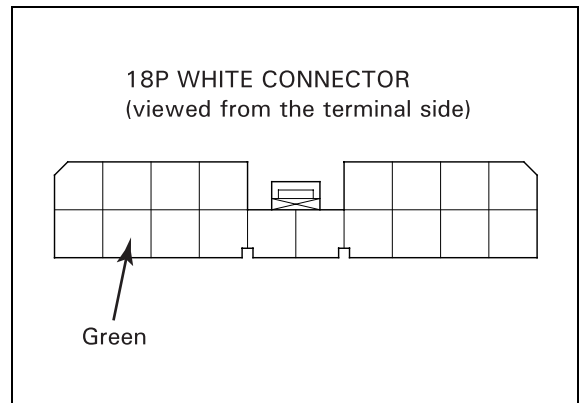

## LIGHTS/METERS/SWITCHES

### Trunk opener unit cannot be locked and unlocked with the transmitter

1. Remove the trunk lid inner cover and disconnect the trunk lock control unit 18P white connector (page 20-46).
2. Unlock the trunk opener unit with the ignition key.  
Connect a 12-V battery (+) terminal to the Yellow wire terminal and (-) terminal to the Red wire terminal momentarily.  
The trunk opener unit should be locked.
  - If the trunk opener unit is locked, go to step 3.
  - If the trunk opener unit is not locked, check the following:
    - lock/unlock actuator (page 20-47)
    - open circuit in the Red and Yellow wires
    - loose or poor contact of related connectors
3. Connect a 12-V battery (+) terminal to the Red wire terminal and (-) terminal to the Yellow wire terminal momentarily.  
The trunk opener unit should be unlocked.
  - If the trunk opener unit is unlocked, replace the trunk opener unit (page 20-48).
  - If the trunk opener unit is not unlocked, replace the trunk lock control unit (page 20-46).

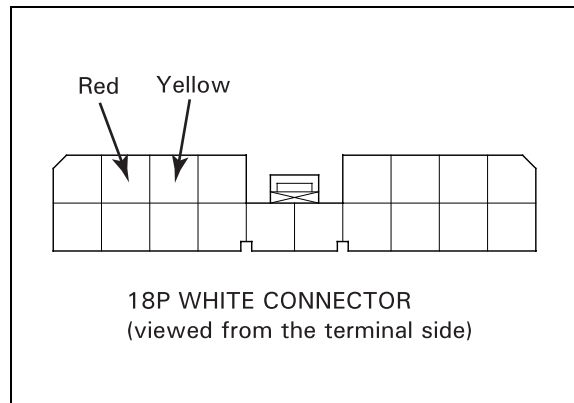

### Trunk opener unit can be unlocked but cannot be locked with the transmitter

Make sure all trunk and saddlebag lids are closed completely.

1. Remove the trunk lid inner cover and disconnect the trunk lock control unit 18P white connector (page 20-46).
2. Check for continuity between the Brown/red wire terminal and ground.  
There should be no continuity.
  - If there is no continuity, go to step 3.
  - If there is continuity, check the following:
    - trunk and saddlebag open switches (pages 20-48 and 20-49)
    - short circuit in the Brown/red, Red/white, White/red and Blue/red wires between the trunk control unit and open switches
3. Unlock the trunk opener unit with the ignition key.  
Check for continuity between the White wire terminal and ground.  
There should be no continuity.
  - If there is no continuity, replace the trunk lock control unit (page 20-46).
  - If there is continuity, check the following:
    - lock/unlock switch (page 20-47)
    - short circuit in the White wire

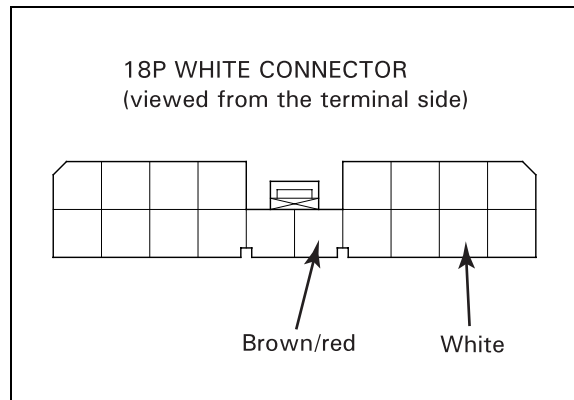



**Trunk opener unit can be locked but cannot be unlocked with the transmitter**

1. Remove the trunk lid inner cover and disconnect the trunk lock control unit 18P white connector (page 20-46).
2. Lock the trunk opener unit with the ignition key. Check for continuity between the Black wire terminal and ground. There should be no continuity.
  - If there is no continuity, replace the trunk lock control unit (page 20-46).
  - If there is continuity, check the following:
    - lock/unlock switch (page 20-47)
    - short circuit in the Black wire

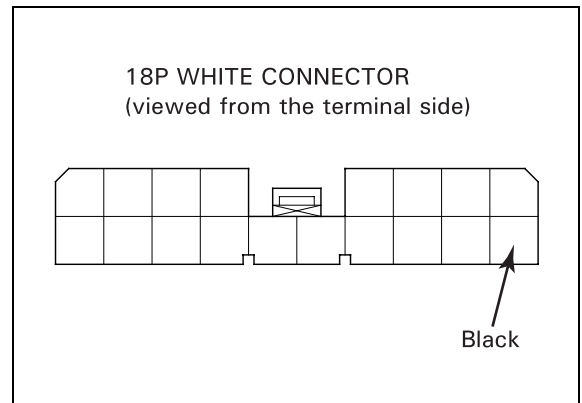

**Trunk opener unit can be locked with the transmitter although one of the lids is open**

- Faulty trunk or saddlebag open switch (pages 20-48 and 20-49)
- Faulty open switch diode (page 20-49)
- Open circuit in the Brown/red, Red/white, White/red and Blue/red wires between the trunk control unit and open switches
- Loose or poor contact of related connectors
- Faulty trunk control unit

**Trunk opener unit can be locked and unlocked with the transmitter but the turn signal lights do not blink**

Make sure that:

- the turn signal/hazard system functions properly.
- ignition switch is turned to "OFF" or "LOCK."

1. Remove the trunk lid inner cover and disconnect the trunk lock control unit 18P white connector (page 20-46).

2. Remove the hazard switch diode (page 20-33). Check the Pink/white wire for continuity between the trunk lock control unit and hazard switch diode. There should be continuity.

- If there is continuity, check the hazard switch diode (page 20-33). If the diode is OK, replace the trunk lock control unit (page 20-46).
- If there is no continuity, check for:
  - open circuit in the Pink/white wire
  - loose or poor contact of related connectors

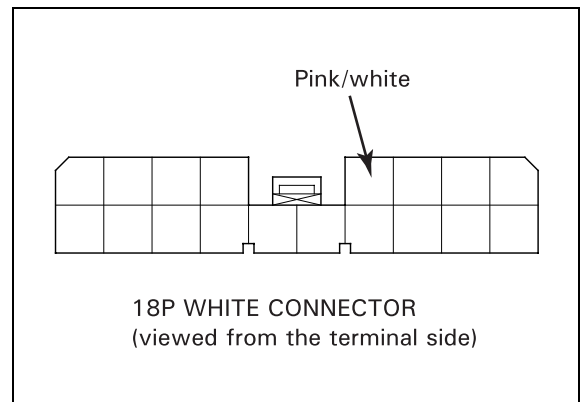

## LIGHTS/METERS/SWITCHES

### Horns do not sound when the "CALL" button is pushed

Make sure that:

- the horns sound when the horn switch is pushed with the ignition switch is turned to "ON" or "ACC."
- the ignition switch is turned to "OFF" or "LOCK."

1. Remove the trunk lid inner cover and disconnect the trunk lock control unit 18P white connector (page 20-46).

2. Ground the Pink wire terminal with a jumper wire.

The horns should sound.

- If the horns sound, replace the trunk lock control unit (page 20-46).
- If the horns do not sound, check the following:
  - HORN (CALL) relay (page 20-16)
  - open circuit in the Pink, Red/yellow and Light green wires

### Trunk lid cannot be opened with the transmitter

- Ignition switch is turned to "ON" or "ACC"
- Faulty trunk lid opener actuator (page 20-47)
- Open circuit in the Blue wire between the trunk control unit and opener actuator
- Open circuit in the Green wire between the opener actuator and ground terminal
- Loose or poor contact in related connectors
- Faulty trunk control unit

### Trunk and saddlebag lid open indicator does not function when one of the lids is open

- Faulty trunk or saddlebag open switch (pages 20-48 and 20-49)
- Open circuit in the following wires:
  - Brown/red wire (for the trunk lid)
  - White/red and Brown/red wires (for the right saddlebag)
  - Blue/red and Brown/red wires (for the left saddlebag)

## TRUNK LOCK CONTROL UNIT REMOVAL/INSTALLATION

Open the trunk lid.

Remove the four screws and two trunk strikers.

Remove the 15 tapping screws and trunk lid inner cover.

Disconnect the 18P white connector from the trunk lock control unit.

Remove the two screws and control unit from the inner cover.

Install the trunk lock control unit in the reverse order of removal.

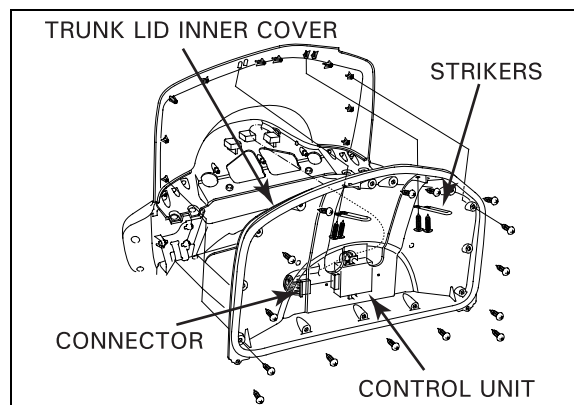
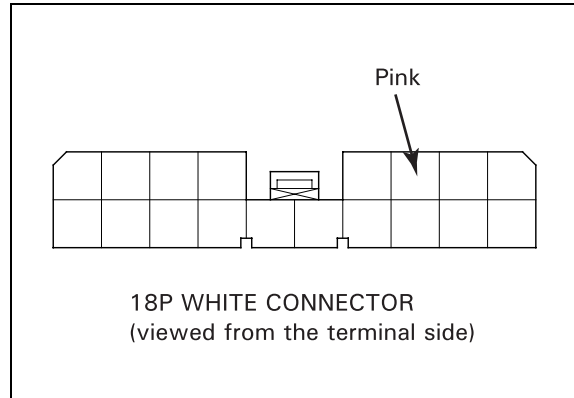

**TRUNK OPENER UNIT INSPECTION**

Remove the trunk lower cover (page 2-14).  
 Disconnect the trunk opener unit 8P connector.

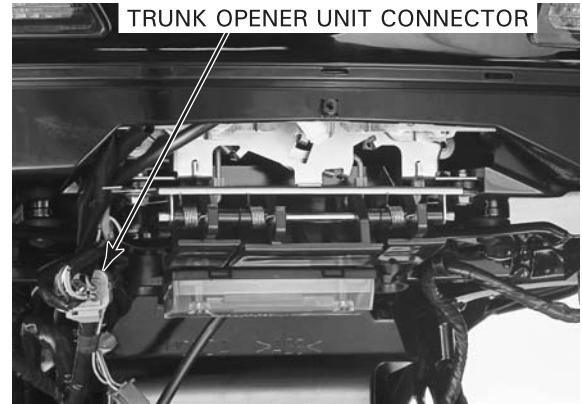

**LOCK/UNLOCK ACTUATOR**

Unlock the trunk opener unit with the ignition key.  
 Connect a 12-V battery (+) terminal to the Yellow wire terminal and (-) terminal to the Red wire terminal momentarily.  
 The trunk opener unit should be locked.

Connect a 12-V battery (+) terminal to the Red wire terminal and (-) terminal to the Yellow wire terminal momentarily.  
 The trunk opener unit should be unlocked.

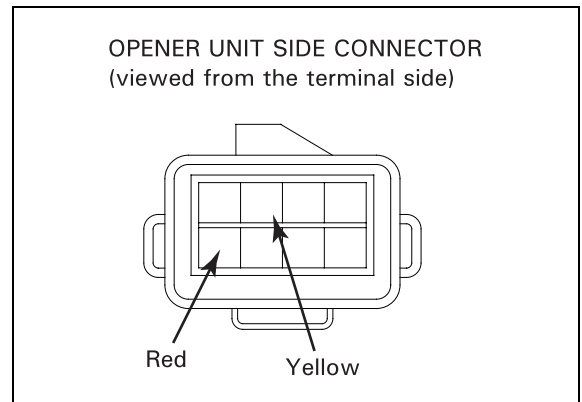

**LOCK/UNLOCK SWITCH**

Check for continuity between the White and Green wire terminals.  
 There should be continuity with the opener unit locked, and no continuity with the unit unlocked.

Check for continuity between the Black and Green wire terminals.  
 There should be continuity with the opener unit unlocked, and no continuity with the unit locked.

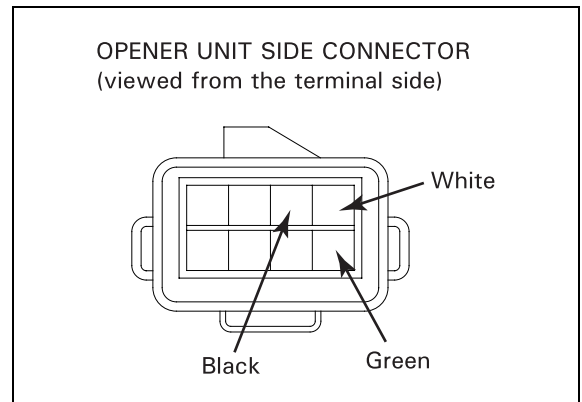

**TRUNK LID OPENER ACTUATOR**

Close the trunk lid.  
 Connect a 12-V battery (+) terminal to the Blue wire terminal and (-) terminal to the Green wire terminal momentarily.  
 The trunk lid should open (pop up).

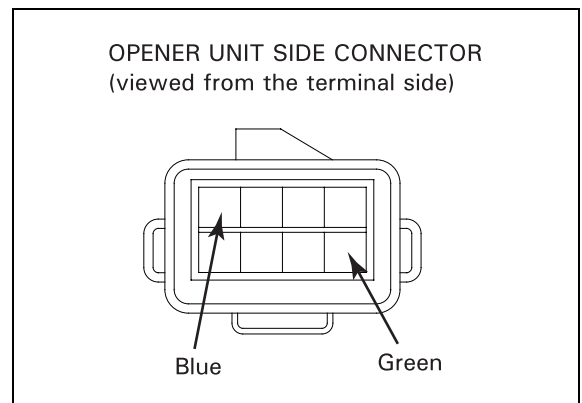

## LIGHTS/METERS/SWITCHES

### TRUNK OPEN SWITCH

Check for continuity between the Brown/red and Green wire terminals. There should be continuity with the trunk lid open and no continuity with the lid closed.

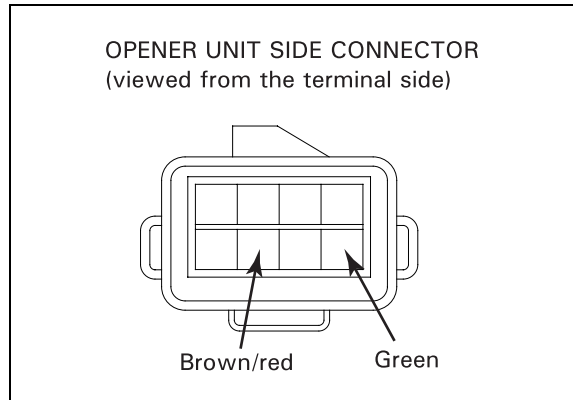

### TRUNK OPENER UNIT REMOVAL/ INSTALLATION

Remove the trunk lower cover (page 2-14).

Remove the trunk and saddlebag opener rods from the snap joints of the opener unit.

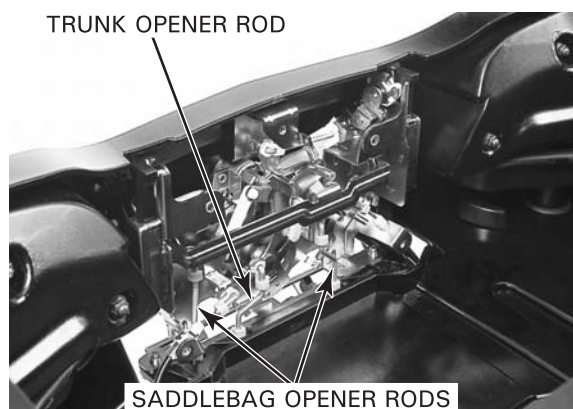

Remove the two bolts and the trunk/saddlebag lid opener lever assembly.

Disconnect the trunk opener unit 8P connector.

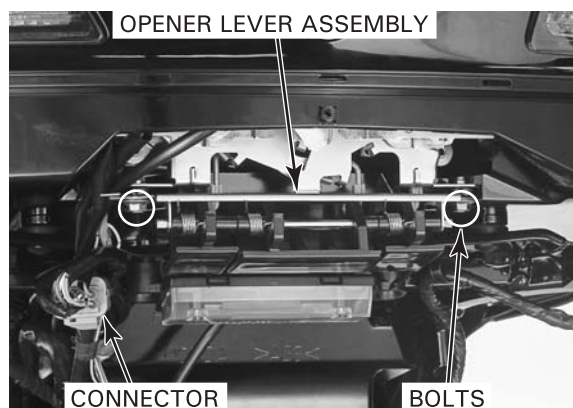

Remove the three screws and the trunk opener unit from the trunk.



Remove the retainer plate and lock cylinder from the trunk opener unit.  
Installation is in the reverse order of removal.

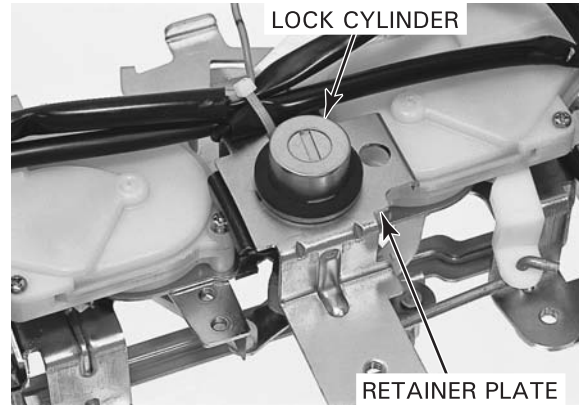

**SADDLEBAG OPEN SWITCH INSPECTION**

Remove rear fender A (page 2-13).  
Disconnect the saddlebag sub-wire harness 2P and 3P connectors (left: red connectors, right: blue connectors).

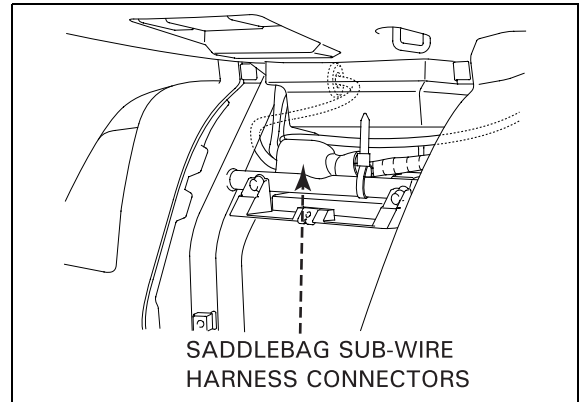

Check for continuity between the Brown/red and Green wire terminals of the saddlebag side connectors.  
There should be continuity with the saddlebag lid open, and no continuity with the lid closed.

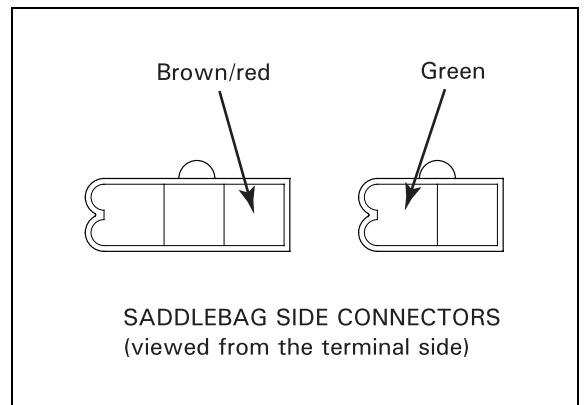

**OPEN SWITCH DIODE INSPECTION**

Remove the seat (page 2-5).  
Remove the trunk/saddlebag open switch diode from the wire harness.

Check for continuity between the diode terminals.  
When there is continuity, a small resistance value will register.

If there is continuity in one direction, the diode is normal.

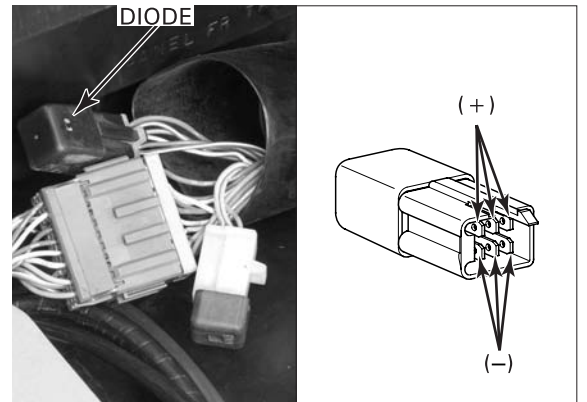

---

**MEMO**

---



# 21. CRUISE CONTROL SYSTEM

---

SYSTEM LOCATION.....	21-2	IGNITION CRUISE RELAY.....	21-11
SERVICE INFORMATION .....	21-3	CRUISE CONTROL SWITCH .....	21-13
TROUBLESHOOTING .....	21-4	CRUISE CANCEL SWITCH .....	21-14
CRUISE/REVERSE CONTROL MODULE .....	21-9	CRUISE ACTUATOR.....	21-16

# CRUISE CONTROL SYSTEM

---

## SYSTEM LOCATION

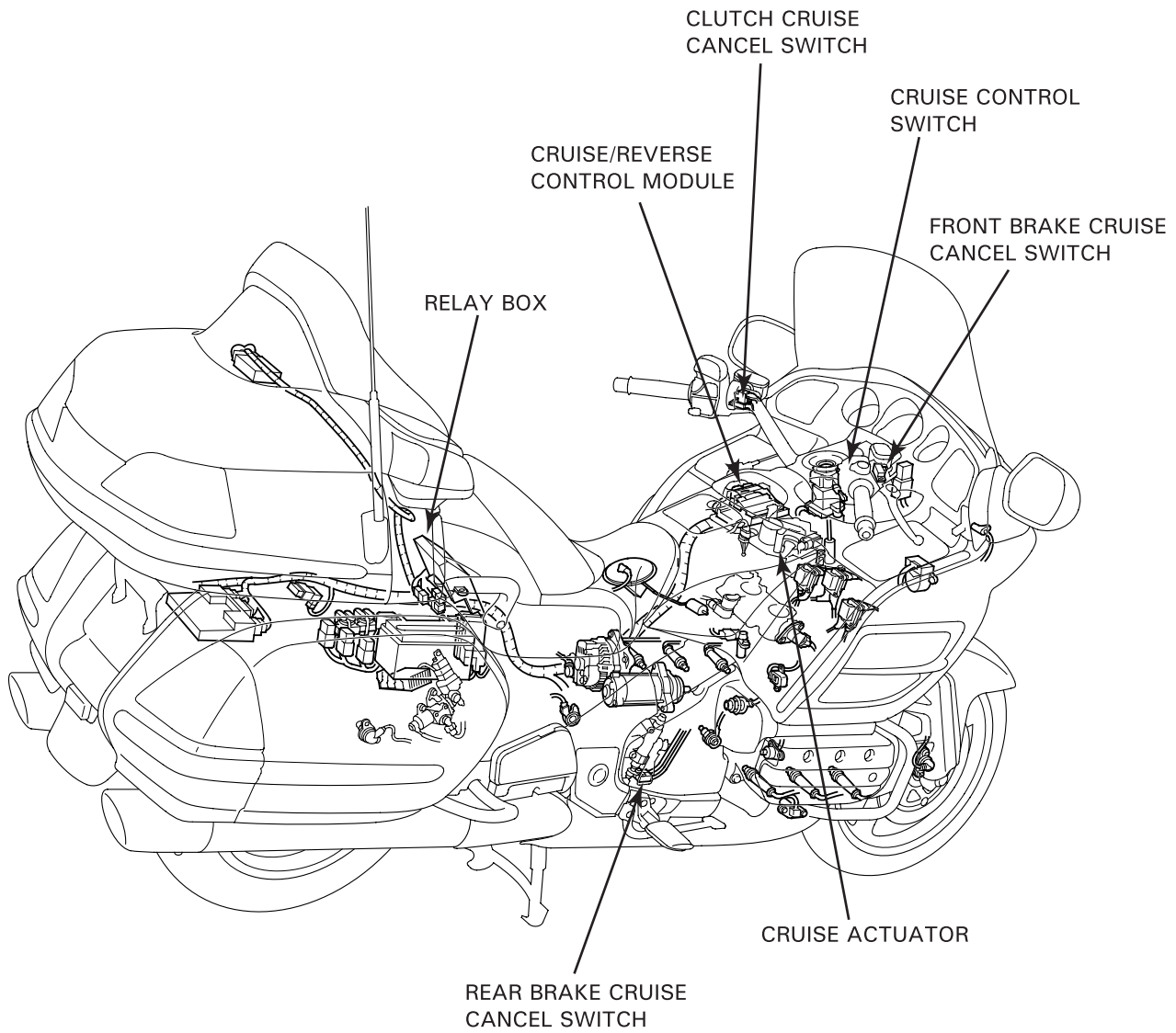

## **SERVICE INFORMATION**

### **GENERAL**

- The cruise control can be set when the motorcycle is running between 30 and 100 mph (48 and 160 km/h) with the transmission in 4th or overdrive.
- The electric cruise actuator is used to control the throttle valve in this cruise control system.
- The cruise control module is integrated with the reverse control module.
- When checking the cruise control system, always follow the steps in the troubleshooting flow chart (page 21-4).

### **SPECIFICATIONS**

<b>ITEM</b>		<b>STANDARD</b>	<b>SERVICE LIMIT</b>
Cruise actuator coil resistance (20° C/68° F)	Clutch coil	35 – 45 $\Omega$	-
	Step motor coil	3 – 7 $\Omega$	-

## CRUISE CONTROL SYSTEM

# TROUBLESHOOTING

**Cruise "ON" indicator does not come on when the cruise main switch is pushed to "ON"**

### 1. Fuse Inspection

NOTE:

- The cruise "ON" indicator should come on when the cruise main switch is pushed to "ON" with the ignition switch turned to "ON" and the engine stop switch to "⏻".
- Make sure the reverse system functions properly.

Check for blown No. 19 fuse.

**Is fuse No. 19 blown?**

**YES** – Replace the fuse with a new one and turn the ignition switch to "ON." If the fuse blows again, check for a short circuit in the related wires.

**NO** – GO TO STEP 2.

### 2. Cruise Power Input Line

Check the cruise power input (No. 14) line at the cruise/reverse control module (page 21-9).

**Does the cruise power input (No. 14) line function as specified?**

**NO** – • Faulty ignition cruise relay or its circuits (page 21-11).  
• Open circuit in the Black/yellow wire between the cruise/reverse control module and ignition cruise relay.

**YES** – GO TO STEP 3.

### 3. Cruise "ON" Indicator Line

Check the cruise "ON" indicator (No. 13) line at the cruise/reverse control module (page 21-9).

**Does the cruise "ON" indicator (No. 13) line function as specified?**

**NO** – GO TO STEP 7.

**YES** – GO TO STEP 4.

### 4. Cruise Main Switch Line

Check the cruise main switch (No. 9) line at the cruise/reverse control module (page 21-9).

**Does the cruise main switch (No. 9) line function as specified?**

**YES** – Faulty cruise/reverse control module.

**NO** – GO TO STEP 5.

### 5. Cruise Main Switch

Check the cruise main switch (page 21-13).

**Does the cruise main switch function?**

**NO** – Faulty cruise main switch; replace the right handlebar switch.

**YES** – GO TO STEP 6.

### 6. Right Handlebar Wiring Harness Voltage

Turn the ignition switch to "ON" with the engine stop switch to "⏻." Measure the voltage between the Black/yellow wire terminal (+) of the wire harness side right handlebar switch connector and ground (-).

**Is there battery voltage?**

**NO** – Open circuit in the Black/yellow wire between ignition cruise relay and right handlebar switch.

**YES** – • Open circuit in the Black/yellow wire between the cruise/reverse control module and right handlebar switch.  
• Loose or poor contact of the related connectors.

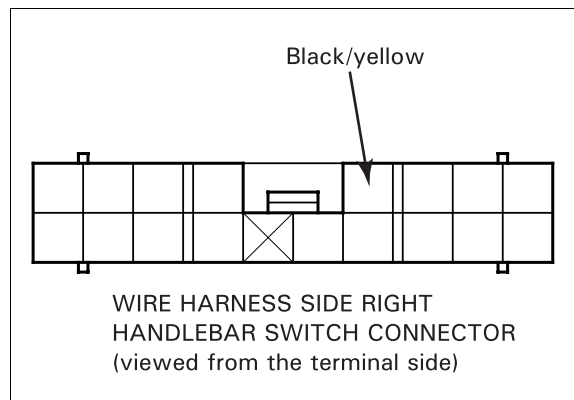

**7. Combination Meter and Cruise/Reverse Module**

Remove the combination meter (page 20-17). Check the Blue-orange wire for continuity between the meter 20P blue connector and cruise/reverse control module 26P black connector.

**Is there continuity?**

- NO** – • Open circuit in the Blue/orange wire.  
• Loose or poor contact of the related connectors.
- YES** – GO TO STEP 8.

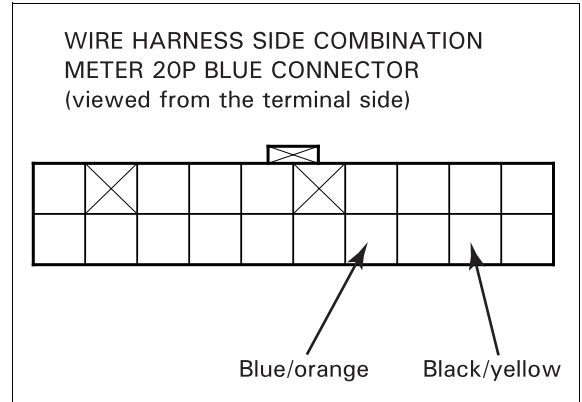

**8. Combination Meter Voltage**

Turn the ignition switch to "ON." Measure the voltage between the Black/yellow wire terminal (+) of the meter 20P blue connector and ground.

**Is there battery voltage?**

- NO** – Open circuit in the Black/yellow wire between the combination meter and ignition cruise relay.
- YES** – Faulty meter/gauge assembly; replace it (page 20-19).

**Cruise "ON" indicator blinks when the cruise main switch is pushed to "ON"**

**1. Relay Coil Line**

NOTE:

- If the cruise actuator relay is faulty, the system will enter the fail-safe mode, and the cruise "ON" indicator will blink when the cruise main switch is pushed to "ON" with the ignition switch turned to "ON" and the engine stop switch to "O."

Check the cruise actuator relay coil (No. 50) line at the cruise/reverse control module.

**Does the relay coil (No. 50) line function as specified?**

- NO** – • Faulty cruise actuator relay (page 21-16).  
• Open circuit in the Black/yellow wire between the ignition cruise and actuator relays.  
• Open or short circuit in the Green/black wire between the cruise/reverse control module and cruise actuator relay.
- YES** – GO TO STEP 2.

**2. Cruise Actuator Relay Signal Line**

Check the cruise actuator relay signal (No. 32) line at the cruise/reverse control module (page 21-9).

**Does the cruise actuator relay signal (No. 32) line function as specified?**

- NO** – • Faulty cruise actuator relay (page 20-16).  
• Open circuit in the Black/yellow wire between the ignition cruise and actuator relays.  
• Open circuit in the Brown/white wire between the cruise/reverse control module and cruise actuator relay.
- YES** – Faulty cruise/reverse control module.

## CRUISE CONTROL SYSTEM

---

**Cruise "SET" indicator starts blinking when the vehicle speed reaches above 25km/h (16 mph) with the main switch pushed to "ON"**

### 1. Cruise Actuator Clutch Line

NOTE:

- The control module self-diagnoses the actuator clutch when the vehicle speed reaches above 25 km/h (16 mph) with the cruise main switch pushed to "ON," and the system will enter fail-safe mode if the actuator clutch is faulty.

Check the cruise actuator clutch (No. 30) line at the cruise/reverse control module (page 21-9).

***Does cruise actuator clutch (No. 30) line function as specified?***

- NO** – • Faulty cruise actuator clutch (page 21-16).  
• Open or short circuit in the Brown/black wire between the cruise/reverse control module and cruise actuator.  
• Open circuit in the Green wire between the cruise actuator and ground terminal.

**YES** – Faulty cruise/reverse control module.

**Cruise control cannot be set**

### 1. Gear Position Switch Line

Check the following before proceeding:

- The cruise "ON" indicator comes on when the cruise main switch is pushed to "ON."
- The cruise actuator cable is adjusted properly (page 21-17).
- The speedometer and tachometer operate properly.

Check the gear position (overdrive) switch (No. 2) line at the cruise/reverse control module (page 21-9).

***Does gear position switch (No. 2) line function as specified?***

- NO** – • Faulty gear position switch (page 20-38).  
• Open circuit in the Green/orange wire between the cruise/reverse control module and gear position switch.

**YES** – GO TO STEP 2.

### 2. Gear Position (4th) Switch Line

Check the gear position (4th) switch (No. 3) line at the cruise/reverse control module (page 21-9).

***Does gear position (4th) switch (No. 3) line function as specified?***

- NO** – • Faulty gear position switch.  
• Open circuit in the Red/white wire between the cruise/reverse control module and gear position switch.

**YES** – GO TO STEP 3.

### 3. Clutch Cruise Cancel Switch Line

Check the clutch cruise cancel switch (No. 4) line at the cruise/reverse control module.

***Does the clutch cruise cancel switch (No. 4) line function as specified?***

**YES** – Faulty clutch cruise cancel switch (page 21-14).

**NO** – GO TO STEP 4.

### 4. "SET/DECEL" Switch Line

Check the cruise "SET/DECEL" switch (No. 6) line at the cruise/reverse control module (page 21-9).

***Does the "SET/DECEL" switch (No. 6) line function as specified?***

- NO** – • Faulty cruise "SET/DECEL" switch (page 21-13).  
• Open circuit in the White/yellow wire between the cruise/reverse control module and right handlebar switch.

**YES** – GO TO STEP 5.

### 5. Speed Sensor Line

Check the speed sensor (No. 7) line at the cruise/reverse control module (page 21-9).

***Does the speed sensor (No. 7) line function as specified?***

- NO** – • Open circuit in the White/black wire between the cruise/reverse control module and speed sensor.

**YES** – GO TO STEP 6.



### 6. Engine Speed Pulse Line

Check the engine speed pulse (No. 21) line at the cruise/reverse control module (page 21-9).

**Does the engine speed pulse (No. 21) line function as specified?**

**NO** – Open circuit in the Yellow/green wire between the cruise/reverse module and engine control module (ECM).

**YES** – GO TO STEP 7.

### 7. Cruise Actuator Clutch Line

Check the cruise actuator clutch (No. 30) line at the cruise/reverse control module (page 21-9).

**Does the cruise actuator clutch (No. 30) line function as specified?**

**NO** –

- Faulty cruise actuator clutch (page 21-16).
- Open or short circuit in the Brown/black wire between the cruise/reverse control module and cruise actuator.
- Open circuit in the Green wire between the cruise actuator and ground terminal.

**YES** – GO TO STEP 8.

### 8. Cruise Cancel Switch Line

Check the cruise cancel switch (No. 31) line at the cruise/reverse control module (page 21-9).

**Does the cancel switch (No. 31) line function as specified?**

**NO** – GO TO STEP 13.

**YES** – GO TO STEP 9.

### 9. Brake Light Line

Check the brake light (No. 35) line at the cruise/reverse control module (page 21-9).

**Does the brake light (No. 35) line function as specified?**

**NO** – Faulty brake light system.

**YES** – GO TO STEP 10.

### 10. Cruise Actuator Motor A Line

Check the cruise actuator motor A (No. 33) line at the cruise/reverse control module (page 21-9).

**Does the cruise actuator motor A (No. 33) line function as specified?**

**NO** –

- Faulty cruise actuator motor (page 21-16).
- Open circuit in the Blue wire between the cruise/reverse control module and cruise actuator.
- Open circuit in the Brown/white wire between the cruise/reverse control module and cruise actuator.

**YES** – GO TO STEP 11.

### 11. Cruise Actuator Motor B Line

Check the cruise actuator motor B (No. 39) line at the cruise/reverse control module (page 21-9).

**Does the cruise actuator motor B (No. 39) line function as specified?**

**NO** –

- Faulty cruise actuator motor (page 21-16).
- Open circuit in the Yellow wire between the cruise/reverse control module and cruise actuator.

**YES** – GO TO STEP 12.

### 12. Cruise Actuator Motor C Line

Check the cruise actuator motor C (No. 45) line at the cruise/reverse control module (page 21-9).

**Does the cruise actuator motor C (No. 45) line function as specified?**

**NO** –

- Faulty cruise actuator motor (page 21-16).
- Open circuit in the Light green wire between the cruise/reverse control module and cruise actuator.

**YES** – Faulty cruise/reverse control module.

## CRUISE CONTROL SYSTEM

---

### 13. Front Brake Cruise Cancel Switch

Check the front brake cruise cancel switch (page 21-14).

#### ***Does the front brake cruise cancel switch function?***

**NO** – • Faulty front brake cruise cancel switch.  
• Open circuit in the Black/yellow wire.

**YES** – GO TO STEP 14.

### 14. Throttle Grip Cruise Cancel Switch

Check the throttle grip cruise cancel switch (page 21-14).

#### ***Does the throttle grip cruise cancel switch function?***

**NO** – • Faulty throttle grip cruise cancel switch.  
• Open circuit in the Green/white wire between the front brake cruise cancel switch and throttle grip cruise cancel switch.

**YES** – GO TO STEP 15.

### 15. Rear Brake Cruise Cancel Switch

Check the rear brake cruise cancel switch (page 21-16).

#### ***Does the rear brake cruise cancel switch function?***

**NO** – • Faulty rear brake cruise cancel switch.  
• Open circuit in the Green/white wire between the throttle grip cruise cancel switch and rear brake cruise cancel switch.

**YES** – Open circuit in the Brown/red wire between the cruise/reverse control module and rear brake cruise cancel switch.

### **Cruise control cannot be cancelled**

#### **1. Clutch Cruise Cancel Switch Line**

NOTE:

- Make sure that the brake lights operate properly.

Check the clutch cruise cancel switch (No. 4) line at the cruise/reverse control module (page 21-9).

#### ***Does the clutch cruise cancel switch (No. 4) line function as specified?***

**NO** – • Faulty clutch cruise cancel switch (page 21-14).  
• Open circuit in the Green/blue wire between the cruise/reverse control module and clutch cruise cancel switch.  
• Open circuit in the Black/yellow wire between the clutch cruise cancel switch and cruise main switch.

**YES** – GO TO STEP 2.

#### **2. Cruise Cancel Switch Line**

Check the cruise cancel switch (No.31) line at the cruise/reverse control module (page 21-9).

#### ***Does the cruise cancel switch (No. 31) line function as specified?***

**NO** – • Faulty front brake cruise cancel switch (page 21-14).  
• Faulty throttle grip cruise cancel switch (page 21-14).  
• Faulty rear brake cruise cancel switch (page 21-16).

**YES** – GO TO STEP 3.

#### **3. Brake Light Line**

Check the brake light (No. 35) line at the cruise/reverse control module (page 21-9).

#### ***Does the brake light (No. 35) line function as specified?***

**NO** – Open circuit in the Green/red wire between the cruise/reverse control module and stop light relay.

**YES** – Faulty cruise/reverse control module.

**Cruise control cannot be resumed**

**1. Cruise RESUME/ACCEL Switch Line**

**NOTE:**

- The cruise control system is turned off (memory is erased) when both the "SET/DECEL" switch and "RESUME/ACCEL" switch are pushed simultaneously.

Check the cruise "RESUME/ACCEL" switch (No. 5) line at the cruise/reverse control module (page 21-9).

**Does the cruise "RESUME/ACCEL" switch (No. 5) line function as specified?**

- NO** – • Faulty cruise "RESUME/ACCEL" switch (page 21-13).  
 • Open circuit in the White/blue wire between the cruise/reverse control module and right handlebar switch.

**YES** – Faulty cruise/reverse control module.

**Cruise control cannot be set but the cruise "SET" indicator does not come on**

**1. Cruise "SET" Switch Line**

Check the cruise "SET" indicator (No. 26) line at the cruise/reverse control module (page 21-9).

**Does the cruise "SET" indicator (No. 26) line function as specified?**

**NO** – Faulty cruise/reverse control module.

**YES** – GO TO STEP 2.

**2. Combination Meter and Cruise/Reverse Control Module**

Remove the combination meter (page 20-17). Check the Blue/white wire for continuity between the meter 20P blue connector and cruise/reverse control module 26P black connector.

**Is there continuity?**

- NO** – • Open circuit in the Blue/white wire.  
 • Loose or poor contact of the related connectors.

**YES** – Faulty meter/gauge assembly; replace it (page 20-19).

**CRUISE/REVERSE CONTROL MODULE**

**SYSTEM INSPECTION**

Remove the top shelter (page 2-11).

Turn the ignition switch "OFF" and disconnect 26P black and gray connectors from the cruise/reverse control module.



Be sure that the engine stop switch is turned to "O."

Check the cruise control system circuits at the wire harness side connector terminals by following the chart on the next page.

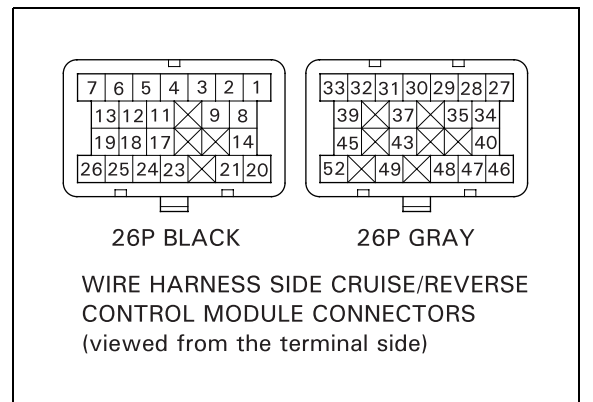

## CRUISE CONTROL SYSTEM

Terminal No. & Circuit		Wire Color & Connection	Conditions	Specification
2	Gear position switch (Overdrive)	Green/orange and ground	Transmission shifted into the overdrive gear	There should be continuity.
			Transmission shifted into any gear except overdrive gear	There should be no continuity.
3	Gear position switch (4th)	Red/white and ground	Transmission shifted into 4th gear	There should be continuity.
			Transmission shifted into any gear except 4th gear	There should be no continuity.
4	Clutch cruise cancel switch	Green/blue (+) and ground (-)	Ignition switch turned to "ON" Cruise main switch turned to "ON" Clutch lever squeezed	There should be battery voltage.
			Ignition switch turned to "ON" Cruise main switch turned to "ON" Clutch lever free	There should be no voltage.
5	"RESUME/ACCEL" switch	White/blue (+) and ground (-)	Ignition switch turned to "ON" Cruise main switch turned to "ON" "RESUME/ACCEL" switch pushed	There should be battery voltage.
			Ignition switch turned to "ON" Cruise main switch turned to "ON" "RESUME/ACCEL" switch free	There should be no voltage.
6	"SET/DECEL" switch	White/yellow (+) and ground (-)	Ignition switch turned to "ON" Cruise main switch turned to "ON" "SET/DECEL" switch pushed	There should be battery voltage.
			Ignition switch turned to "ON" Cruise main switch turned to "ON" "SET/DECEL" switch free	There should be no voltage.
7	Speed sensor	White/black (+) and ground (-)	Ignition switch turned to "ON" Rear wheel turned slowly	0 to 5 V pulse voltage should appear.
9	Cruise main switch	Black/yellow (+) and ground (-)	Ignition switch turned to "ON" Cruise main switch turned to "ON"	There should be battery voltage.
13	CRUISE ON indicator	Blue/orange	Ground wire with a jumper wire and turn the ignition switch to "ON."	CRUISE ON indicator should come on.
14	Cruise power input	Black/yellow (+) and ground (-)	Ignition switch turned to "ON"	There should be battery voltage.
20	Ground	Green and ground	-	There should be continuity.
21	Engine speed pulse	Yellow/green (+) and ground (-)	Crank the engine with the starter motor.	* There should be 10.5 V or more.
26	CRUISE SET indicator	Blue/white	Ground it with a jumper wire and turn the ignition switch to "ON."	CRUISE SET indicator should come on.
30	Cruise actuator clutch	Brown/black and ground	-	There should be 35 – 45Ω
			Connect the 12-V battery (+) to Brown/black and (-) to ground.	Actuator clutch should click.
31	Cruise cancel switch	Brown/red (+) and ground (-)	Ignition switch turned to "ON" Cruise main switch turned to "ON" Brake lever and pedal free	There should be battery voltage.
			Ignition switch turned to "ON" Cruise main switch turned to "ON" Brake lever squeezed or brake pedal depressed	There should be no voltage.
32	Cruise actuator relay output	Brown/white (+) and ground (-)	Ignition switch turned to "ON"	There should be no voltage.
			Ground the No. 50 Green/black with a jumper wire and turn ignition switch to "ON."	There should be battery voltage.
33	Cruise actuator motor A	Blue and No. 32 Brown/white	-	There should be 3 – 7Ω

Terminal No. & Circuit		Wire Color & Connection	Conditions	Specification
35	Brake light	Green/red (+) and ground (-)	Ignition switch turned to "ON" Brake lever and pedal free	There should be no voltage.
			Ignition switch turned to "ON" Brake lever squeezed or brake pedal depressed	There should be battery voltage.
39	Cruise actuator motor B	Yellow and No. 32 Brown/white	-	There should be 3 – 7Ω
45	Cruise actuator motor C	Light green and No. 32 Brown/white	-	There should be 3 – 7Ω
50	Cruise actuator relay coil	Green/black (+) and ground (-)	Ignition switch turned to "ON"	There should be battery voltage.
52	Ground	Green and ground	-	There should be continuity.

\* Measure the voltage using the peak voltage tester (U.S.A. only) or peak voltage adaptor (07HGJ-0020100/not available in U.S.A.) with commercially available digital multimeter (impedance 10 MΩ/DCV minimum).

## IGNITION CRUISE RELAY

### INSPECTION

Remove the seat (page 2-5).

Remove the two screws and remove the relay box.  
Remove the relay blocks from the relay box.

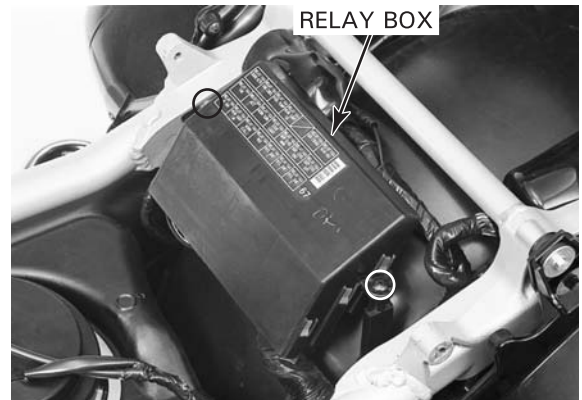

1. Turn the ignition switch to "OFF" and remove the ignition cruise relay and cruise actuator relay.



2. Check the Black/yellow wire for continuity between the ignition cruise relay and cruise actuator relay.

There should be continuity.

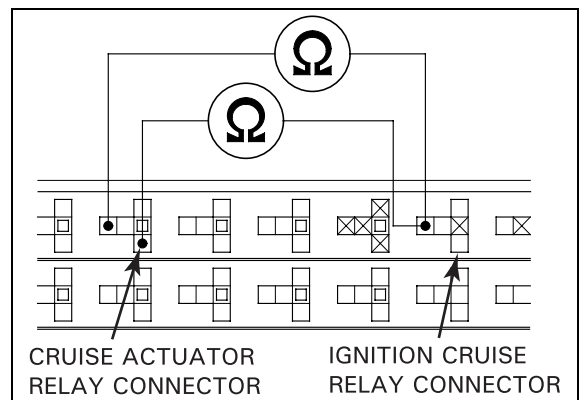

## CRUISE CONTROL SYSTEM

3. Exchange the ignition cruise relay with the a known-good one.

Turn the ignition switch to "ON."

Measure the voltage between the Black/yellow wire terminal (+) of the cruise actuator relay connector and ground (-).

There should be battery voltage.

- If there is battery voltage, replace the ignition cruise relay with a new one.
- If there is no voltage, go to step 4.

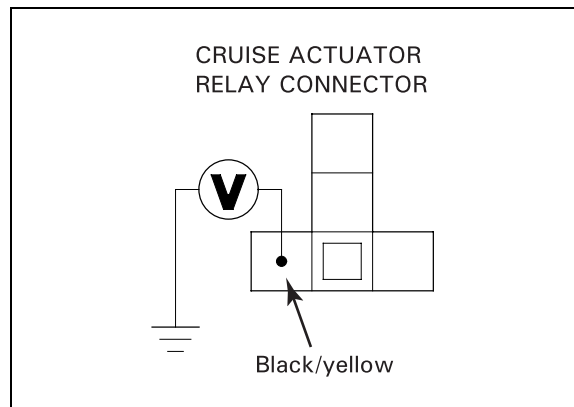

4. Turn the ignition switch to "OFF" and remove the ignition cruise relay.

Check for continuity between the Green wire terminal of the relay connector and ground.

There should be continuity.

- If there is continuity, go to step 5.
- If there is no continuity, repair the open circuit in the green wire.

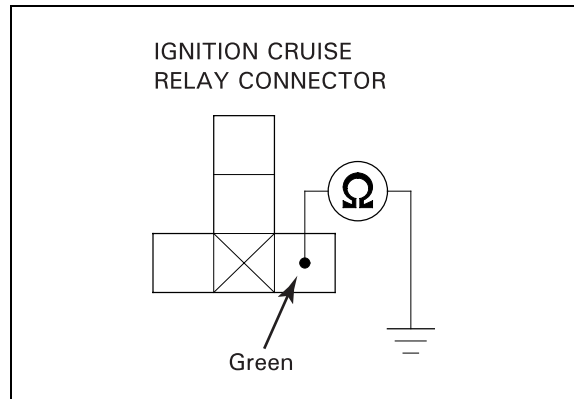

5. Measure the voltage between the Yellow wire terminal (+) of the relay connector and ground (-).

There should be battery voltage.

- If there is battery voltage, go to step 6.
- If there is no voltage, check for an open circuit in the Yellow wire between the ignition cruise relay and fuse box (No. 19 fuse).

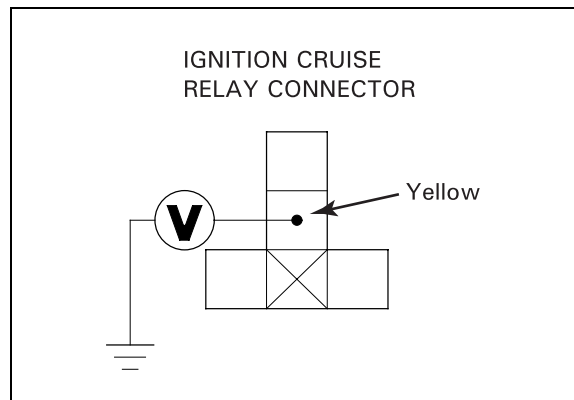

6. Turn the ignition switch to "ON."

Measure the voltage between the Black/yellow wire terminal (+) of the relay connector and ground (-).

There should be battery voltage.

- If there is battery voltage, the system is OK; check for loose contacts or corroded terminals.
- If there is no voltage, check for an open circuit in the Black/yellow wire between the ignition cruise relay and the PGM-FI ignition relay.

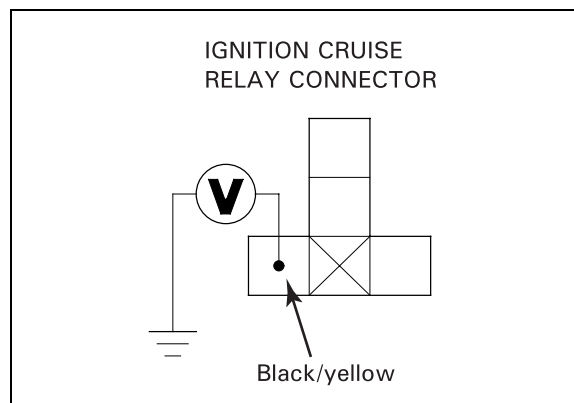



**CRUISE CONTROL SWITCH**

Remove the front fairing (page 2-10).

Disconnect the right handlebar switch 18P green (After '03: blue) connector.

Check for continuity between the connector terminals in each switch position. Continuity should exist between the color coded wires as shown in the charts below.



**CRUISE MAIN SWITCH**

Color Position	White	Black/yellow
FREE		
PUSH (LOCK)	○ — ○	○ — ○

**SET/DECEL SWITCH**

Color Position	White/yellow	Black/yellow
FREE		
PUSH	○ — ○	○ — ○

**RESUME/ACCEL SWITCH**

Color Position	White/blue	Black/yellow
FREE		
PUSH	○ — ○	○ — ○

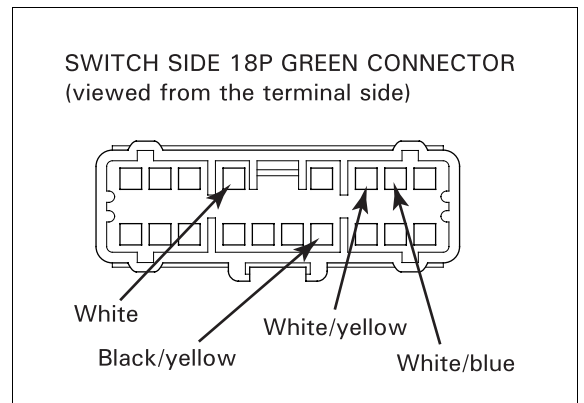
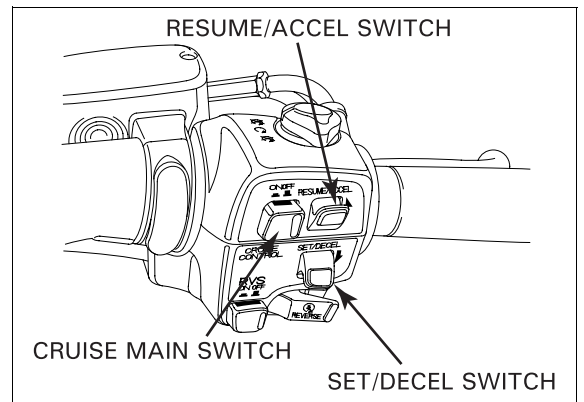

## CRUISE CONTROL SYSTEM

### CRUISE CANCEL SWITCH

#### CLUTCH

**NOTE:**

- The lower switch is the clutch cruise cancel switch.

Disconnect the clutch switch wire connectors and check for continuity between the switch terminals.

There should be continuity with the clutch lever squeezed and no continuity with the lever released.

Turn the ignition switch to "ON" and push the cruise main switch to "ON."

Measure the voltage between the Black/yellow wire terminal (+) and ground (-).

There should be battery voltage.



#### FRONT BRAKE

**NOTE:**

- The lower (large) terminals are the cruise cancel switch terminals.

Disconnect the front brake switch connectors and check for continuity between the switch terminals.

There should be no continuity with the front brake lever squeezed and continuity with the lever released.

Turn the ignition switch to "ON" and push the cruise main switch to "ON."

Measure the voltage between the Black/blue wire terminal (+) and ground (-).

There should be battery voltage.



#### THROTTLE GRIP

Remove the air cleaner housing (page 5-57).

Disconnect the throttle grip cruise cancel switch 2P blue connector.

Check for continuity between the switch side connector terminals.

There should be continuity with the throttle grip in any position.

Turn the throttle grip to open the throttle, hold the throttle drum then close the throttle grip. There should be no continuity.

Turn the ignition switch to "ON" and push the cruise main switch to "ON."

Measure the voltage between the Green/white wire without the brown tube terminal (+) of the wire harness side connector and ground (-).

There should be battery voltage.



### SWITCH REPLACEMENT

Disconnect the throttle grip cruise cancel switch 2P blue connector.

Remove the return side throttle cable from the cable stay and disconnect it from the throttle drum.

Remove the left radiator (page 6-10).

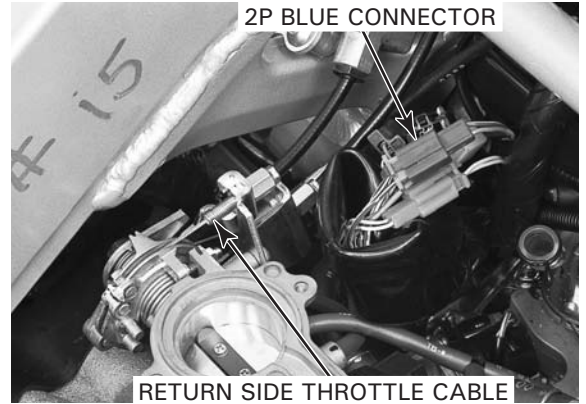

Remove the two bolts and proportional control valve (PCV) from the stay.

Remove the stay mounting bolt.

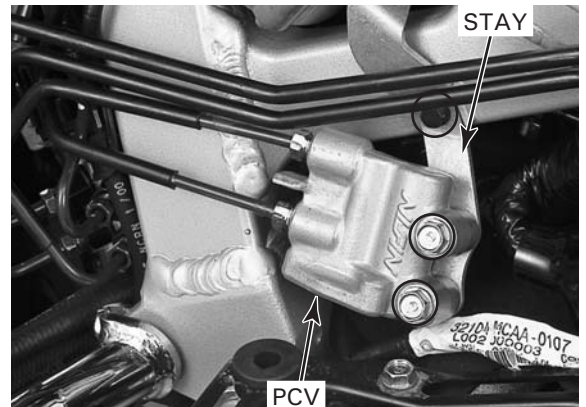

Remove the two socket bolts and stay from the cancel switch.

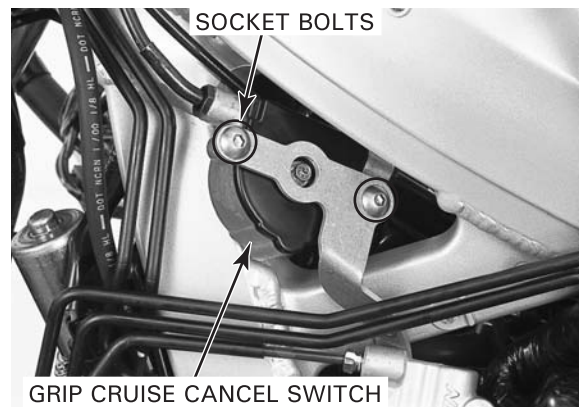

Remove the center bolt and switch cover.



## CRUISE CONTROL SYSTEM

Disconnect the throttle cables from the switch drums and remove them from the switch housing.

*Apply grease to the sliding portions of the switch.*

Install a new throttle grip cruise cancel switch and removed parts in the reverse order of removal.

### TORQUE:

**PCV mounting bolt: 12 N·m (1.2 kgf·m, 9 lbf·ft)**

After installation check the throttle grip free play and adjust as necessary (page 3-5).



## REAR BRAKE

Remove the top shelter (page 2-11).

Disconnect the rear brake cruise cancel switch 2P red connector and check for continuity between the switch side connector terminals.

There should be no continuity with the rear brake pedal depressed and continuity with the pedal released.

Turn the ignition switch to "ON" and push the cruise main switch to "ON."

Measure the voltage between the Green/white wire terminal (+) of the wire harness side connector and ground (-).

There should be battery voltage.

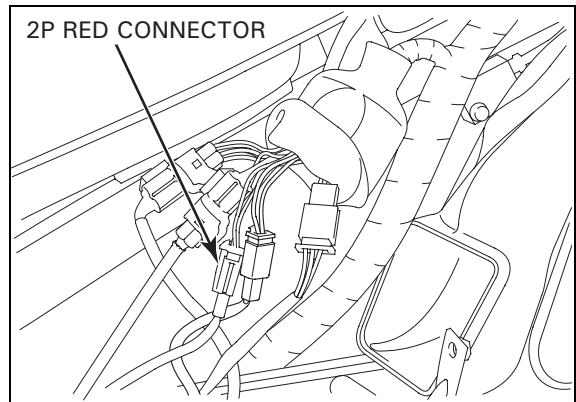

## CRUISE ACTUATOR

### INSPECTION

Remove the top shelter (page 2-11).

Disconnect the cruise actuator 6P black connector. Check the connector for loose contacts or corroded terminals.



### ACTUATOR CLUTCH

Connect a 12-V battery (+) terminal to the No. 6 terminal of the actuator connector and battery (-) terminal to the No. 3 terminal.

The actuator clutch should click.

### ACTUATOR MOTOR

Measure the motor coil resistances between the No. 1 and No. 2 terminals, the No. 1 and No. 4 terminals, and the No. 1 and No. 5 terminals.

**STANDARD: 3 – 5Ω**

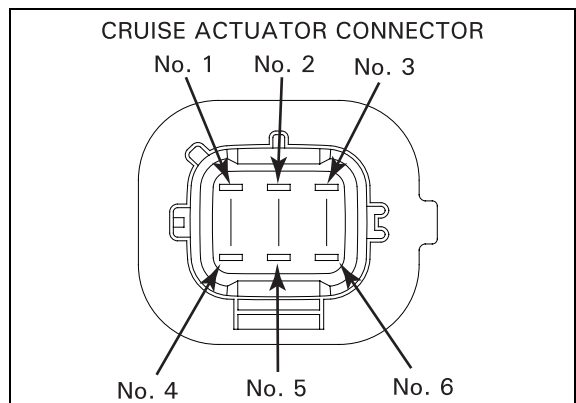



**REPLACEMENT**

Remove the air cleaner housing (page 5-57).

Remove the cruise actuator cable from the cable stay, and disconnect it from the actuator drum.

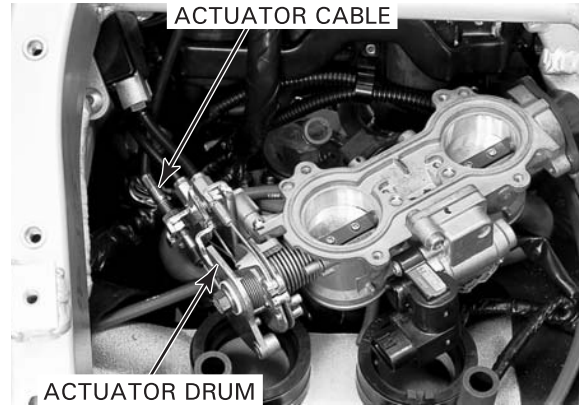

Remove the three tapping screws and the cruise actuator unit from the control unit holder.

Install a new cruise actuator unit onto the control unit holder and tighten the three tapping screws.

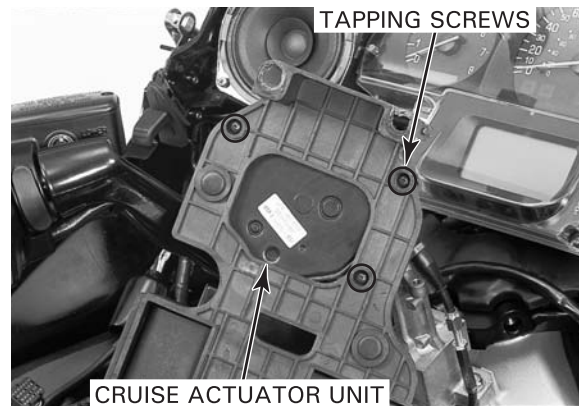

Connect the cruise actuator cable to the actuator drum and install it onto the cable stay. Adjust the cable position with the nuts so that the distance between the cable cap screw end and stay is 34 mm (1.34 in) as shown.

Install the air cleaner housing (page 5-57).

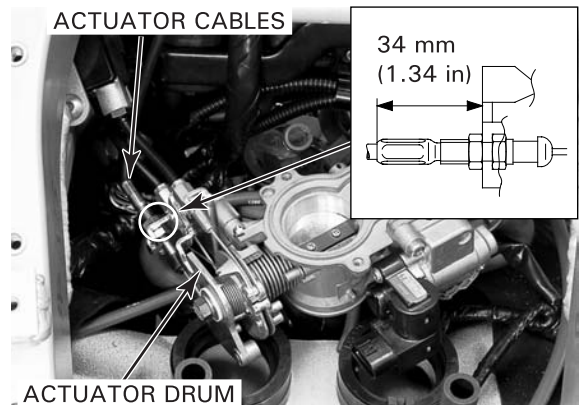

**ACTUATOR CABLE ADJUSTMENT**

Remove the top shelter (page 2-11).

Check that the projection of the actuator drum aligns with the groove of the throttle drum by looking through the hole as shown with a light.

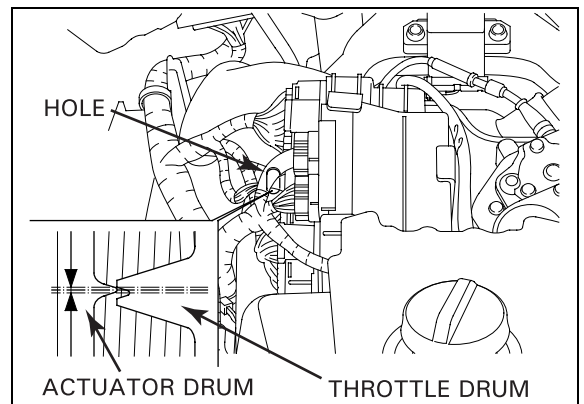

## CRUISE CONTROL SYSTEM

---

Loosen the lock nut and adjust the cruise actuator cable by turning the adjusting nut as required.  
Install the top shelter (page 2-11).

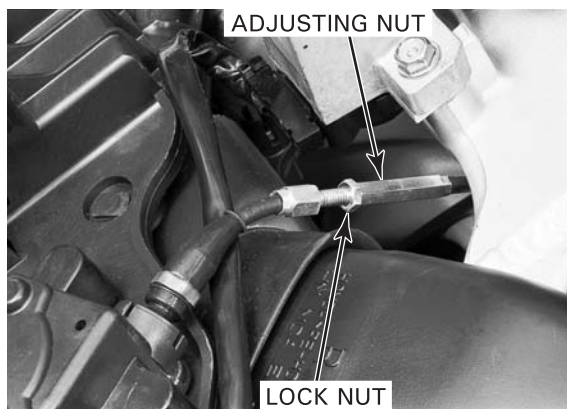



# 22. AUDIO SYSTEM

---

SYSTEM LOCATION.....	22-2	AUDIO SWITCH.....	22-9
SERVICE INFORMATION .....	22-3	ANTENNA.....	22-11
TROUBLESHOOTING .....	22-4	SPEAKER.....	22-12
AUDIO UNIT.....	22-6	HEADSET JUNCTION WIRE .....	22-12

## AUDIO SYSTEM

### SYSTEM LOCATION

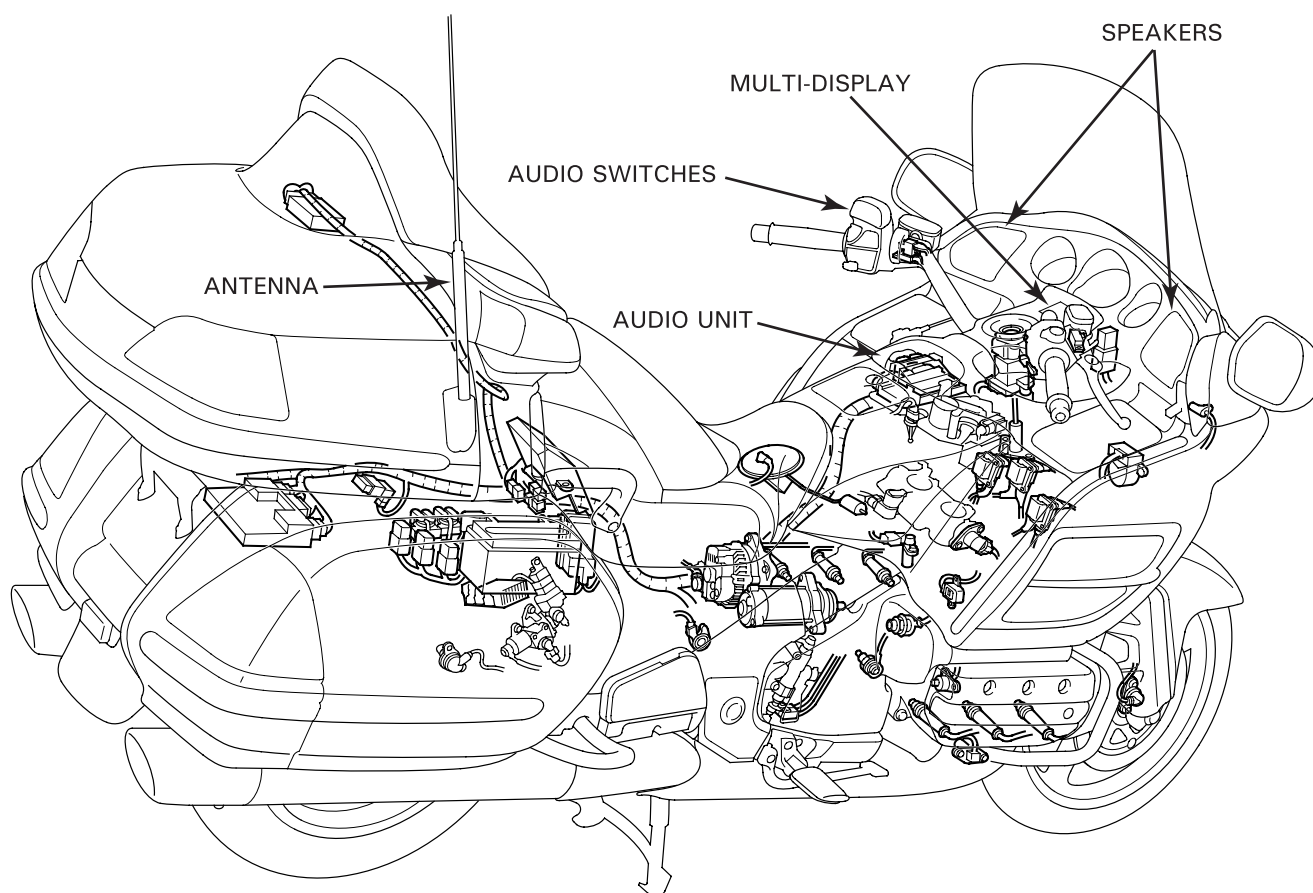

## **SERVICE INFORMATION**

### **GENERAL**

- When checking the audio system, always follow the steps in the troubleshooting flow chart (page 22-4).
- All memorized radio channels are erased when the battery cable is disconnected.
- The AM frequency moves in sequence in 10 kHz steps. The FM frequency moves in sequence in 0.2 MHz steps.
- The “ambience” (AMB) circuit blends and boosts certain frequencies from both channels for a “live performance” effect. AMB may be used for stereo programs from the FM radio. However, the ambience circuit may make weak FM stereo signals sound worse.

### **TORQUE VALUE**

Antenna base mounting bolt                      14 N·m (1.4 kgf·m, 10 lbf·ft)

# TROUBLESHOOTING

**NOTE:**

- Check the radio reception by tuning to a station known to have a strong signal.
- Check that the following fuses are good:
  - No. 21 fuse (15 A)
  - No. 22 fuse (20 A)
- Check that the multi-display indication function operates properly.

**No sound from speakers**

**1. Audio Unit Connections Inspection**

**NOTE:**

- Select the speaker with the "AUDIO" button when the audio system output is headset.

Remove the top shelter (page 2-12).

Check the audio unit 34P black and gray connectors for loose or poor contact.

***Do all wires make good contact?***

**NO** – Correct the faulty part.

**YES** – GO TO STEP 2.

**2. Audio Back-up Line Inspection**

Check the audio back-up line (page 22-6).

***Is battery voltage present?***

**NO** – Open circuit in the Red/yellow wire between the audio unit and fuse.

**YES** – GO TO STEP 3.

**3. Accessory Power Line Inspection**

Check the accessory power line (page 22-6).

***Is battery voltage present?***

**NO** – Open circuit in the Light green/black wire between the audio unit and relay.

**YES** – GO TO STEP 4.

**4. Audio Ground Line Inspection**

Check the ground line (page 22-6).

***Is there continuity?***

**NO** – Open circuit in the Green wire between the audio unit and ground terminal.

**YES** – GO TO STEP 5.

**5. Speaker Output Voltage Inspection**

Measure the speaker output voltage (page 22-6).

***Is voltage present?***

**NO** – • Open or short circuit in the wire between the audio unit and speaker.  
• Faulty audio unit.

**YES** – Faulty speaker(s).

**Radio works, but audio switch does not function****1. Audio Switch Inspection**

Check the audio switch that does not function (page 22-9).

***Does the switch test OK?***

**NO** – Faulty audio switch.

**YES** – GO TO STEP 2.

**2. Audio Switch Line Inspection**

Check the related audio switch lines (page 22-7).

***Is continuity correct?***

**NO** – Open or short circuit in wire between the audio switch and audio unit.

**YES** – • Loose or poor related connection.  
• Faulty audio unit.

**Weak or noisy reception****1. Antenna Connection Inspection****NOTE:**

- Use of the ambience (AMB) circuit may cause weak FM signals.
- As FM stereo reception becomes weaker, special circuits in the radio gradually blend the sound toward monaural to maintain some sound quality, even though the “STEREO” indication remains on.

Remove the seat (page 2-5).

Check for loose or poor antenna connection.

***Are all antenna connections good?***

**NO** – Correct the faulty part.

**YES** – GO TO STEP 2.

**2. Antenna Base Inspection**

Check the antenna base (page 22-11).

***Is continuity correct?***

**NO** – Faulty antenna base.

**YES** – • Loose or poor related connection.  
• Faulty condenser in the alternator or cooling fan motor.  
• Faulty audio unit.

**AVC (Auto Volume Control) does not work at all****1. Speedometer Inspection**

Check that the speedometer operates properly.

***Is the speedometer operating properly?***

**NO** – Check the speedometer (page 20-20).

**YES** – GO TO STEP 2.

**2. Speed Pulse Signal Line Inspection**

Check the speed pulse signal line (page 22-8).

***Is the voltage within the specified voltage?***

**NO** – Open or short circuit in White/black wire between the combination meter and audio unit.

**YES** – • Loose or poor related connection.  
• Faulty audio unit.

**Radio works, but audio display does not appear****1. Audio Display Signal Line Inspection**

Check the audio display signal lines (page 22-7).

***Is continuity correct?***

**NO** – Open or short circuit in the wire between the combination meter and audio unit.

**YES** – • Loose or poor related connection.  
• Faulty audio unit.

## AUDIO SYSTEM

### AUDIO UNIT

#### POWER/GROUND LINE INSPECTION

Remove the top shelter (page 2-12).

Check the following at the audio unit 34P black connector terminals.

#### BACK-UP LINE

Measure the voltage between the Red/yellow wire terminal (+) and ground (-).

There should be battery voltage at all times.

#### ACCESSORY POWER LINE

Measure the voltage between the Light green/black wire terminal (+) and ground (-).

There should be battery voltage with the ignition switch turned to "ON" or "ACC."

#### GROUND LINE

Check for continuity between the Green wire terminal and ground.

There should be continuity at all times.

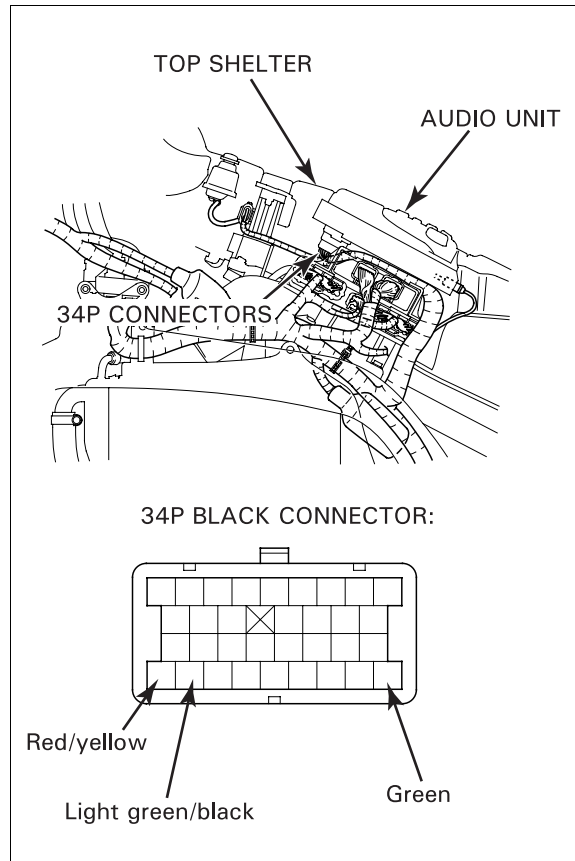

#### SPEAKER OUTPUT VOLTAGE INSPECTION

Remove the speakers (page 22-12).

Select the AC range on the tester.

*The voltage should increase or decrease in accordance with the volume.*

Measure the voltage between the connector terminals at each speaker.

#### CONNECTIONS:

**LEFT SPEAKER: Blue/green (+) – Gray/black (-)**

**RIGHT SPEAKER: Red/green (+) – Brown/black (-)**

There should be voltage with the radio turned on.

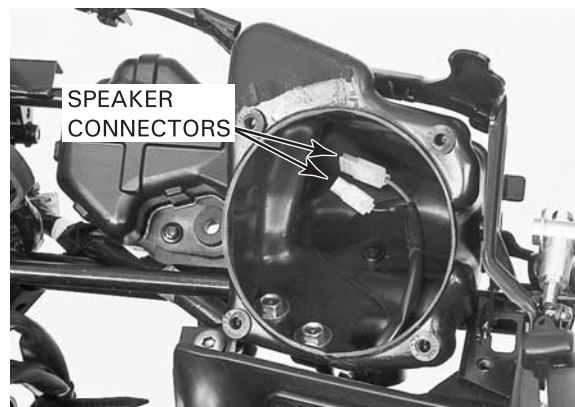



**MAIN WIRE HARNESS INSPECTION**

Remove the top shelter (page 2-12).

**AUDIO SWITCH LINES**

Remove the front fairing (page 2-10).

Disconnect the left handlebar switch connectors.

- '01 – '03:
- 14P blue
- 12P green

- After '03:
- 14P gray
- 12P blue

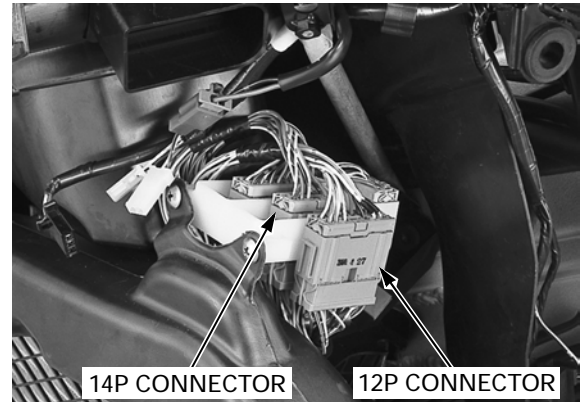

Check for continuity between the audio unit 34P and handlebar (audio) switch connectors as shown. There should be continuity between the same color wire terminals.

Also, check for a short circuit between each connector terminal and ground. There should be no continuity.

**34P (black) – 14P**

- No. 11: Orange
- No. 12: White
- No. 19: Green
- No. 20: Brown
- No. 21: Black
- No. 28: Red
- No. 29: Yellow

**'01 – '03: 34P (gray) – 14P**

**After '03: 34P (gray) – 12P**

- No. 10: Light green

Check for continuity between the Green wire terminal of the handlebar (audio) switch 12P connector and ground.

There should be continuity.

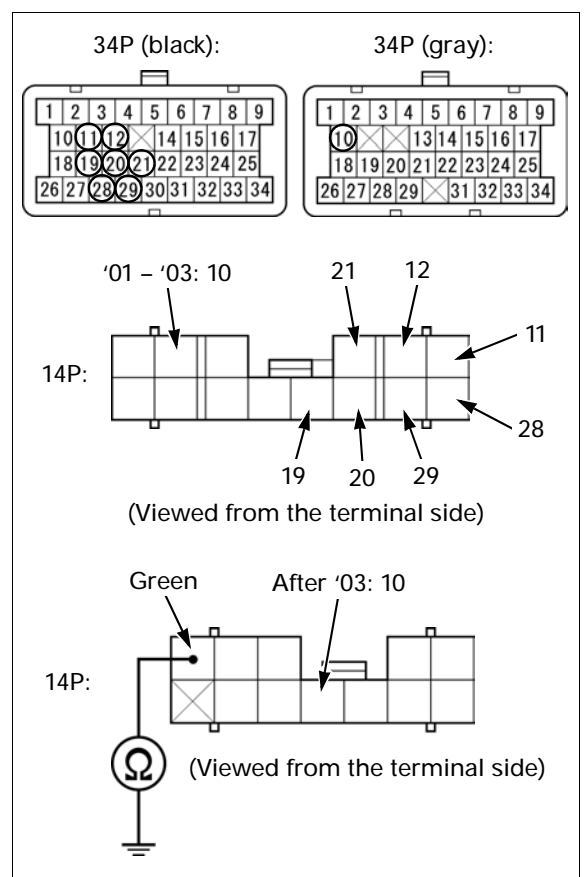

**AUDIO DISPLAY SIGNAL LINES**

Remove the combination meter (page 20-17).

Check for continuity between the audio unit 34P black and meter 16P connectors. There should be continuity between the same color wire terminals.

Also, check for a short circuit between each connector terminal and ground. There should be no continuity.

- No. 1: Red
- No. 2: Black
- No. 3: Shield
- No. 10: Green
- No. 18: White

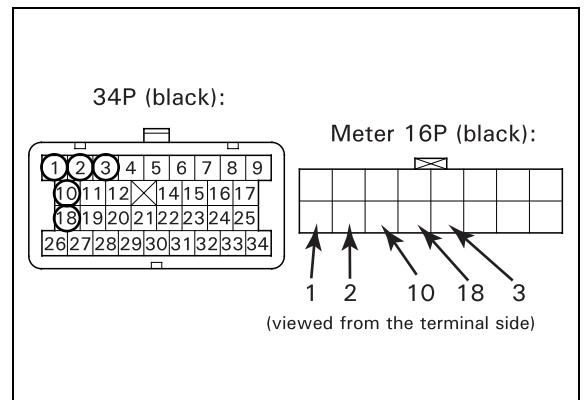

## AUDIO SYSTEM

### SPEED PULSE SIGNAL LINE

Place the motorcycle on its center stand, then shift the transmission into neutral.

Measure the voltage between the White/black wire terminal (+) of the audio unit 34P (gray) connector and ground (-) with the ignition switch turned to "ON."

There should be 0 V to 5 V pulse voltage while slowly turning the rear wheel by hand.

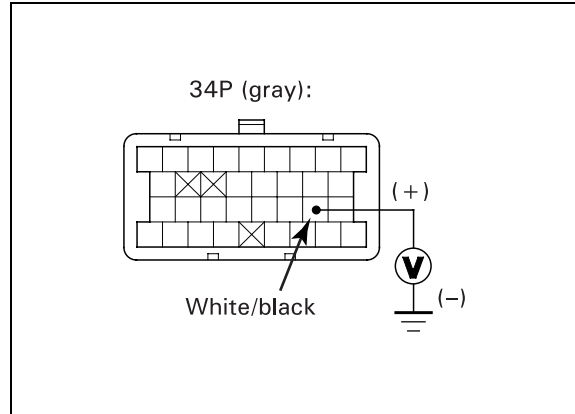

### STARTER/REVERSE SWITCH LINE

Measure the voltage between the Yellow/red wire terminal (+) of the audio unit 34P gray connector and ground (-) with the ignition switch turned to "ON" and the engine stop switch turned to "⌚."

There should be battery voltage when the starter/reverse switch is pushed

If there is no voltage, check the following:

- open or short circuit in the Yellow/red wire
- loose or poor contact in related connectors

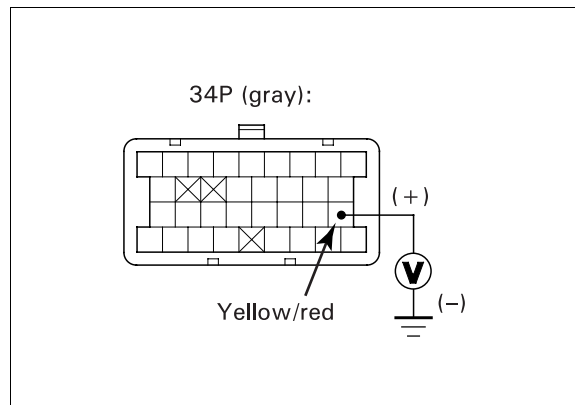

### REMOVAL/INSTALLATION

Remove the top shelter (page 2-12).

Remove the ten screws and separate the front and rear top shelters.

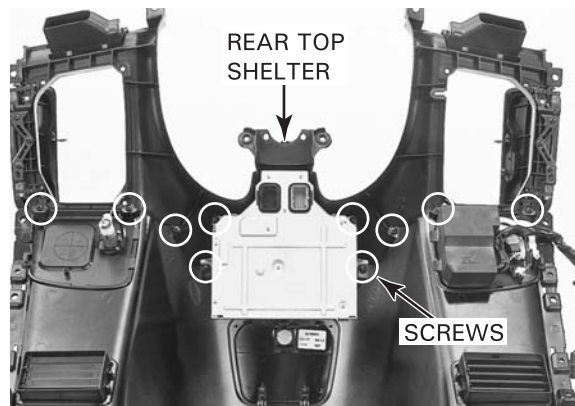

Remove the two screws and audio unit.

Install the audio unit in the reverse order of removal.

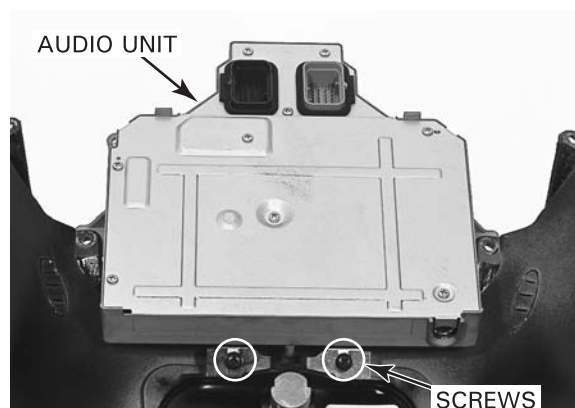

# AUDIO SWITCH

## INSPECTION

Remove the front fairing (page 2-10).

Disconnect the left handlebar switch connectors.

'01 - '03:

- 14P blue
- 12P green

After '03:

- 14P gray
- 12P blue

Check for continuity between the connector terminals in each switch position.

Continuity should exist between the color coded wire terminals as follows:

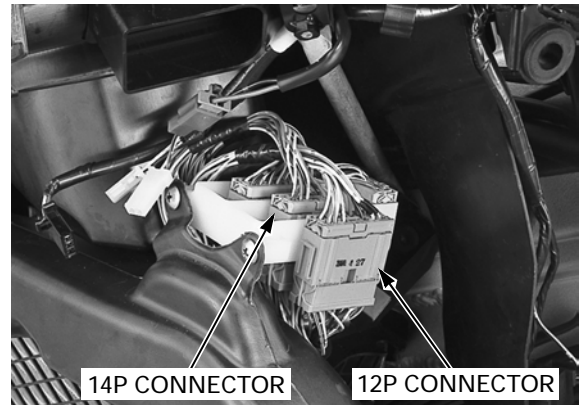

## TERMINAL ARRANGEMENT AND SWITCH LOCATION

### CB-VOL SWITCH

Color	Black	Orange	Red
Up	○	○	
Free			
Down	○		○

### CB-CH SWITCH

Color	Brown	Orange	Red
Up	○	○	
Free			
Down	○		○

### CB-SQL SWITCH

Color	Green2	Orange	Red
Up	○	○	
Free			
Down	○		○

### VOLUME SWITCH

Color	Black	White	Yellow
Up	○	○	
Free			
Down	○		○

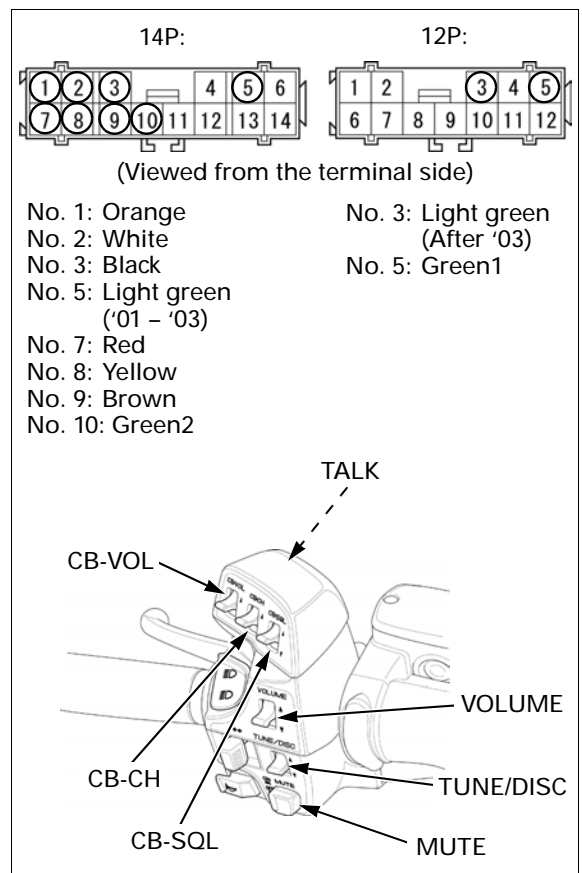

# AUDIO SYSTEM

---

## TUNE/DISC SWITCH

Color Position	Black	White	Yellow
Up			
Free			
Down			

## MUTE SWITCH

Color Position	Green1	Light green
Free		
Push		

## TALK SWITCH

Color Position	Green2	Yellow
Free		
Push		

# ANTENNA

## REMOVAL/INSTALLATION

Loosen the lock nut and remove the antenna from the base by turning it counterclockwise.

Remove the seat (page 2-5).

Open the trunk lid, and remove the four screws and right trunk side pocket.

Remove the wire band.

Disconnect the antenna connector located under the frame cross-member and remove the antenna wire out of the frame.

Remove the three bolts, stay and antenna base assembly.

Installation is in the reverse order of removal.

### TORQUE:

**Antenna base bolt: 14 N·m (1.4 kgf·m, 10 lbf·ft)**

*Route the wires properly (page 1-23).*

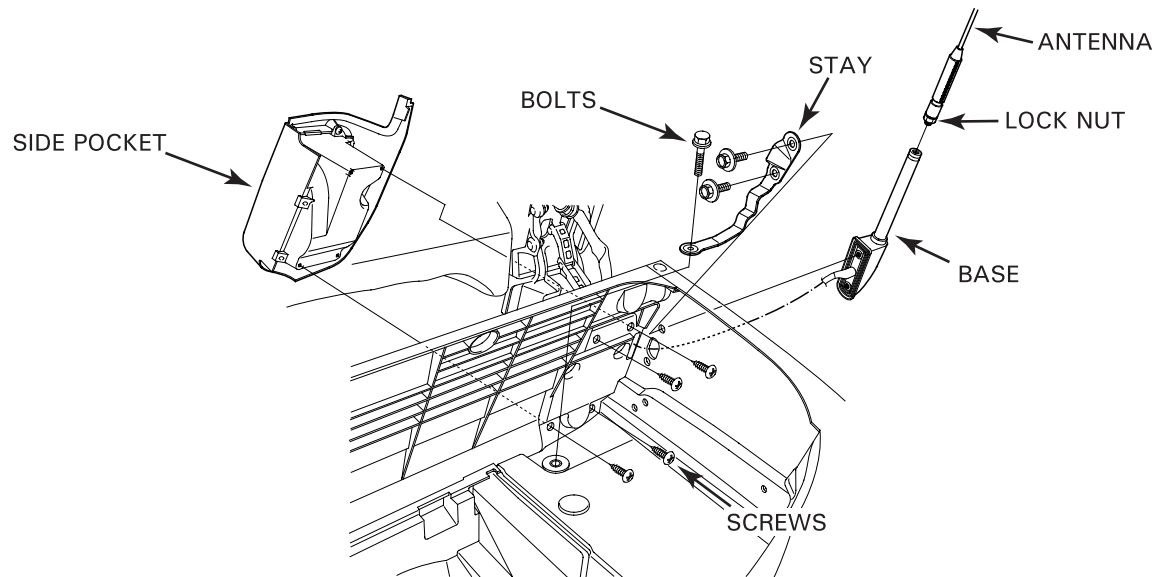
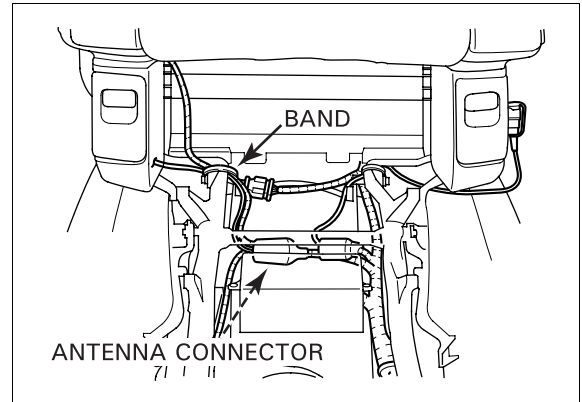

## INSPECTION

Remove the seat (page 2-5).

Disconnect the antenna connector.

Remove the antenna from the antenna base (page 22-11).

Check for continuity between the antenna connector and base as shown.

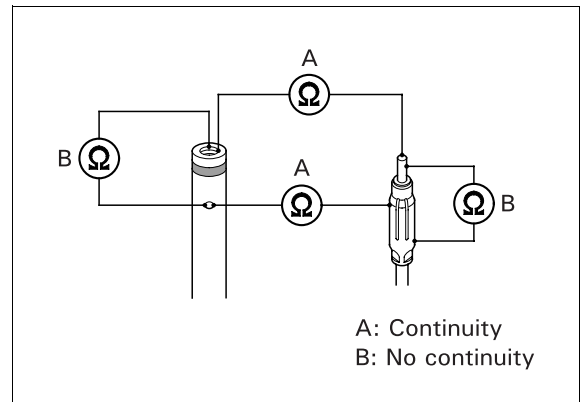

## AUDIO SYSTEM

### SPEAKER

#### REMOVAL/INSTALLATION

Remove the meter panel (page 2-7).

Remove the four mounting screws.  
Disconnect the connectors to remove the speaker.

Install the speaker in the reverse order of removal.

#### INSPECTION

*Select smallest range on the ohmmeter.* Connect an analogue ohmmeter to the speaker terminals.  
The speaker is normal if the speaker clicks at the moment when the ohmmeter probes are connected to the speaker terminals.

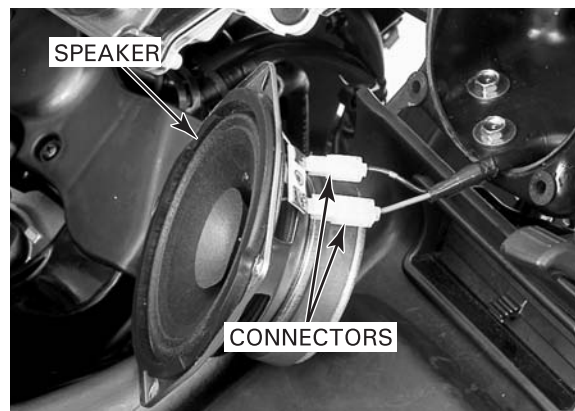

### HEADSET JUNCTION WIRE

#### INSPECTION

*Front headset:* Remove the left fairing pocket (page 2-11).

*Rear headset:* Remove the seat (page 2-5).

Disconnect the junction wire 6P red connector.  
Check for continuity between the same color (number) wire terminals of the 6P connector and junction connector.  
There should be continuity.

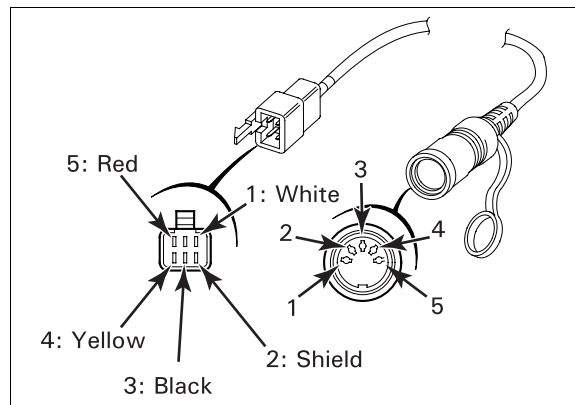



# 23. WIRING DIAGRAM

---

SERVICE INFORMATION .....	23-3	STARTER/REVERSE SYSTEM.....	23-12
FUSE BOX .....	23-3	LIGHTING SYSTEM.....	23-13
SUSPENSION LEVEL CONTROL SYSTEM	23-5	TURN SIGNAL LIGHTS/HORN .....	23-14
ABS.....	23-7	COMBINATION METER .....	23-15
FUEL SYSTEM (Programmed Fuel Injection) .....	23-9	ACC/TRUNK LOCK CONTROL SYSTEM ..	23-17
COOLING/CHARGING/IGNITION SYSTEM .....	23-11	CRUISE CONTROL SYSTEM .....	23-20
		AUDIO SYSTEM .....	23-22

# WIRING DIAGRAM

## SERVICE INFORMATION

### GENERAL

- The following abbreviations are used to identify wire colors in this section.

Bl: Black  
Br: Brown  
Bu: Blue  
G: Green  
Gr: Gray  
Lb: Light blue  
Lg: Light green  
O: Orange  
P: Pink  
R: Red  
S: Shield wire  
W: White  
Y: Yellow

## FUSE BOX

### FUSE NUMBER

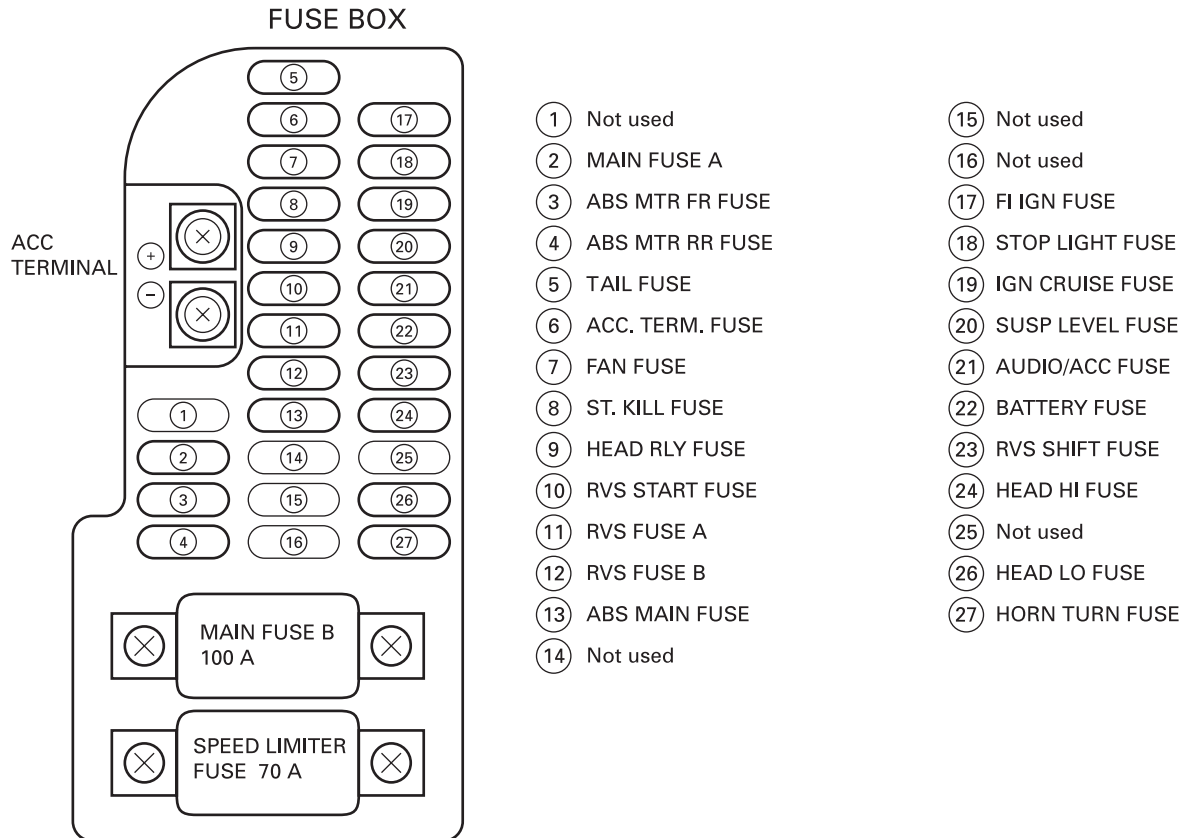

# WIRING DIAGRAM CONNECTION

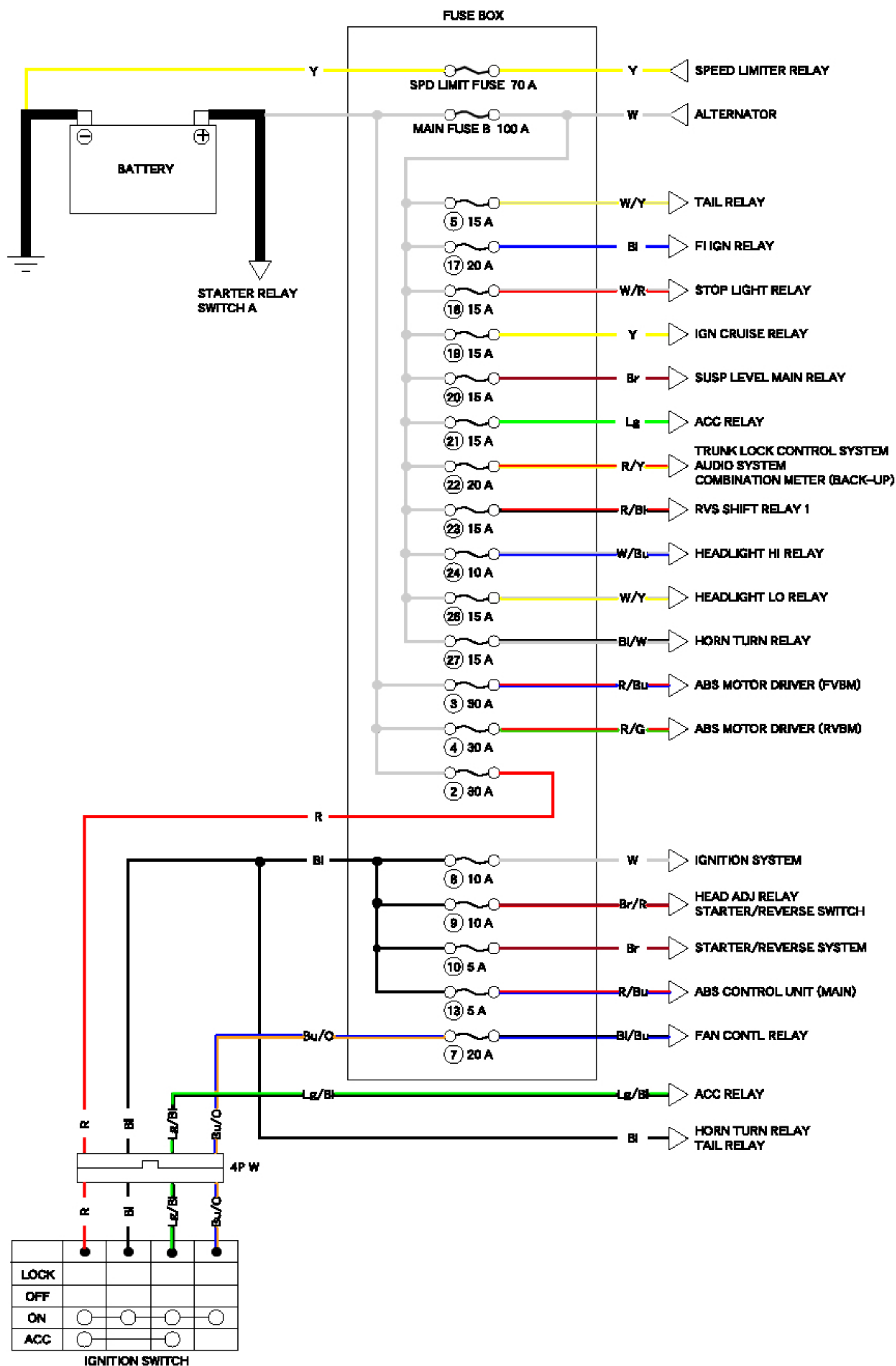

# SUSPENSION LEVEL CONTROL SYSTEM

'01:

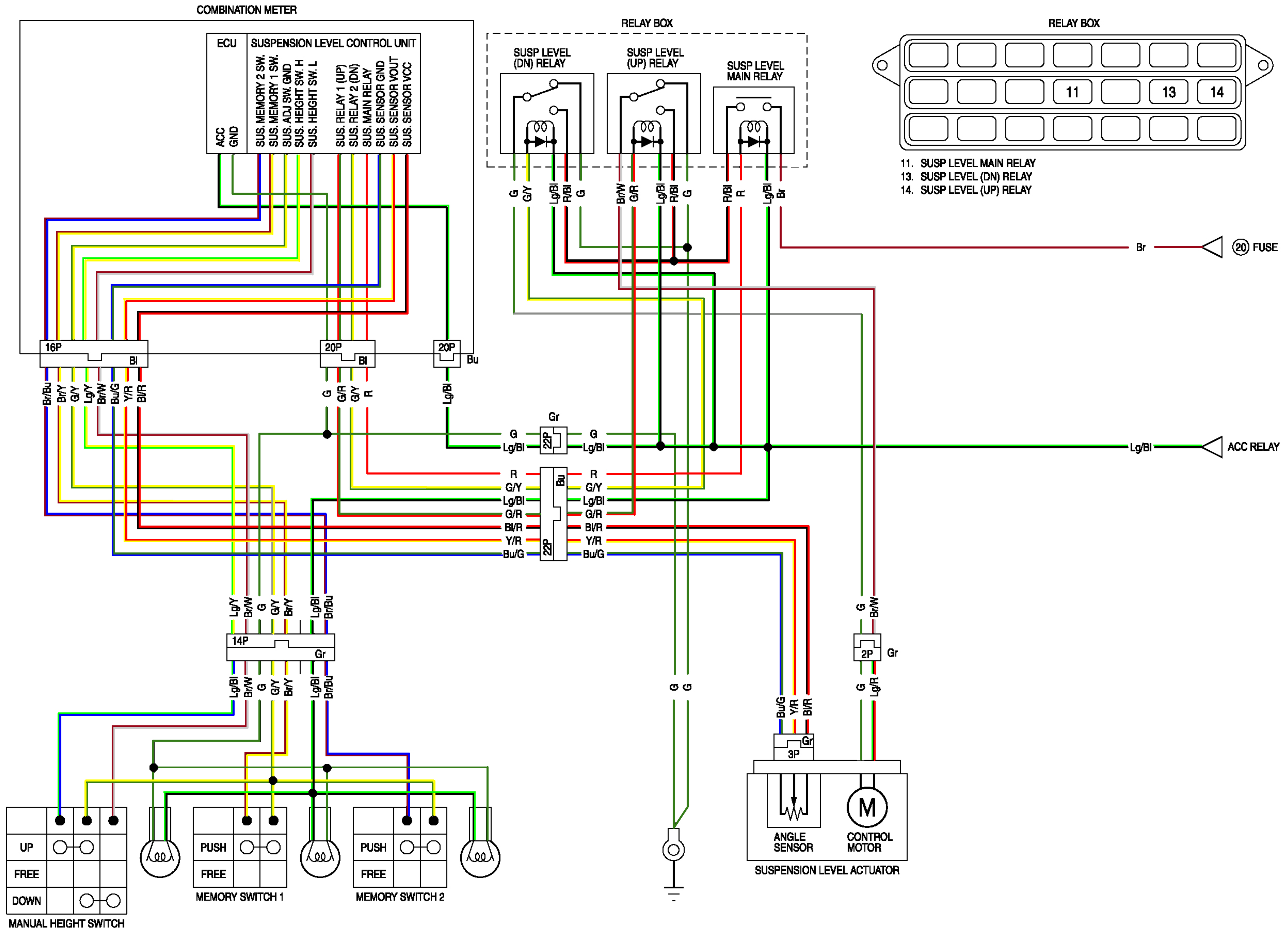

# WIRING DIAGRAM

After '01:

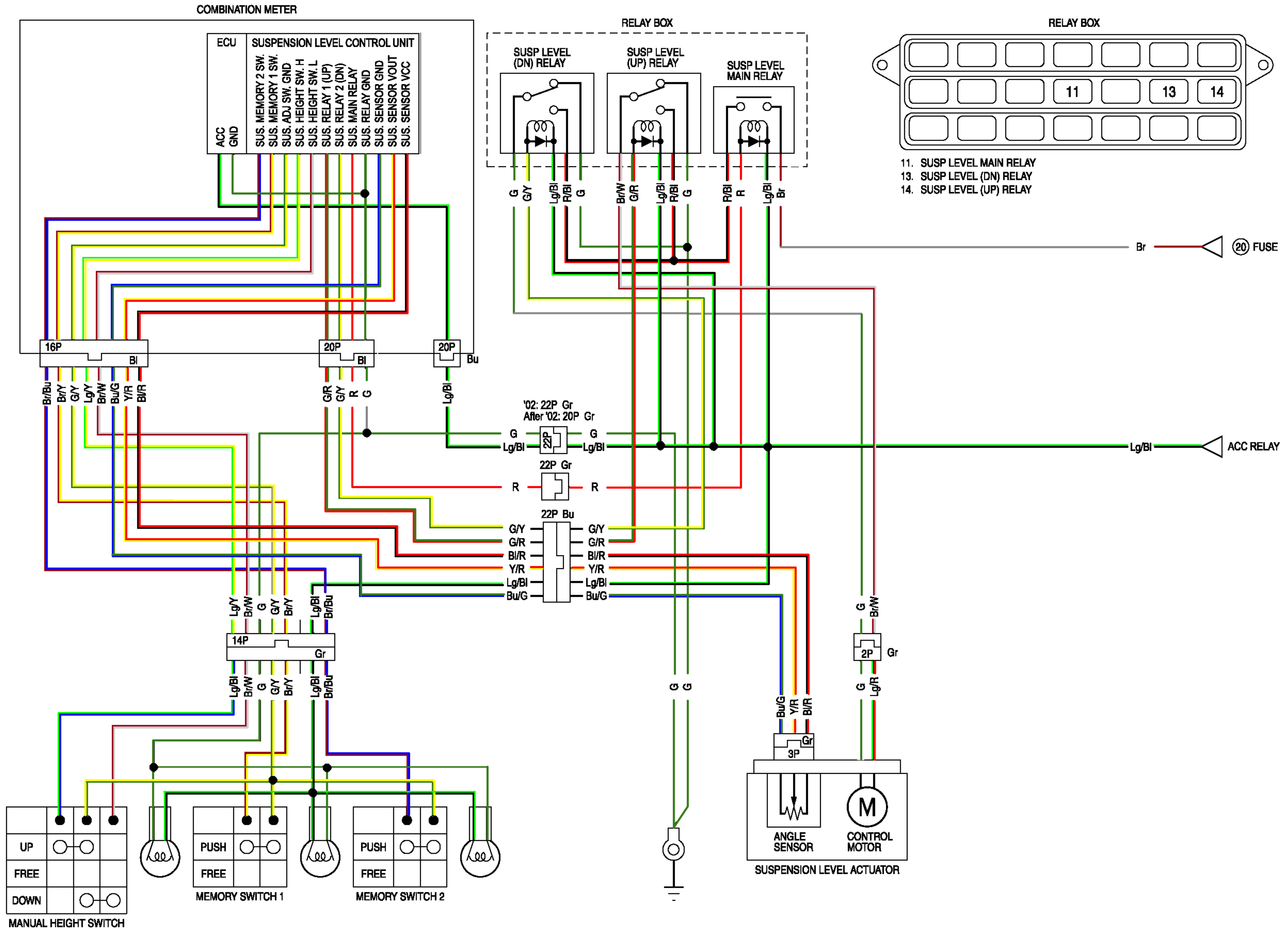



# ABS

'01:

## COMBINATION METER

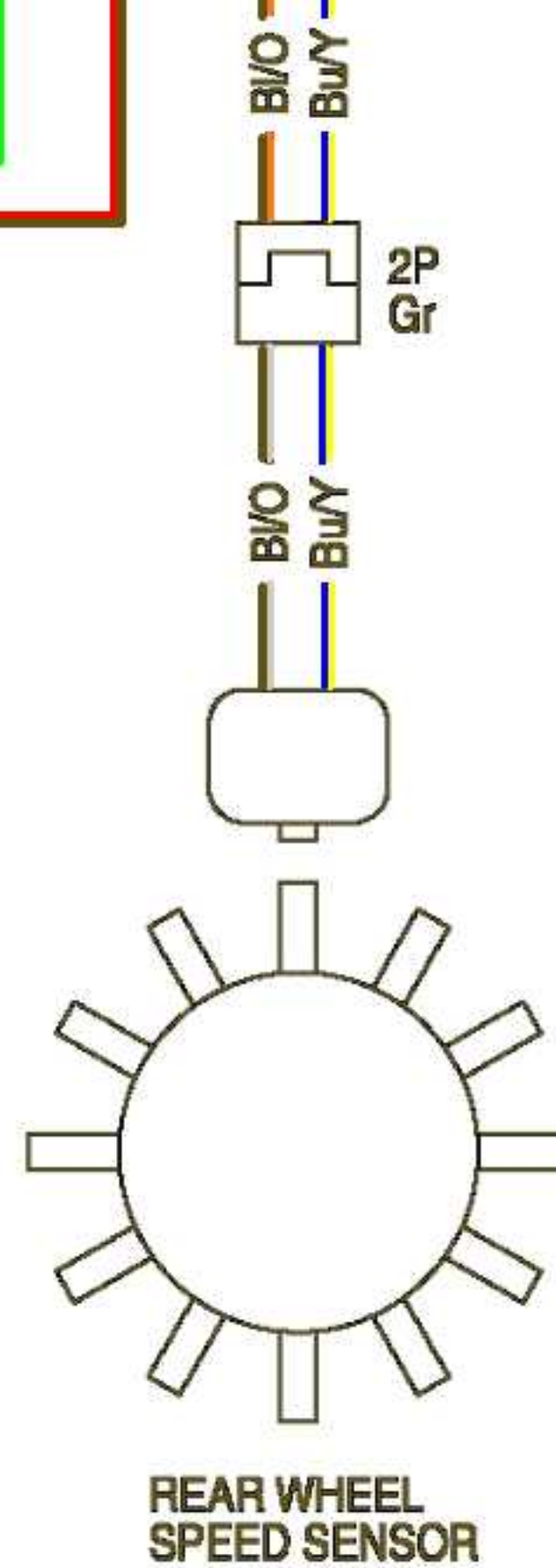
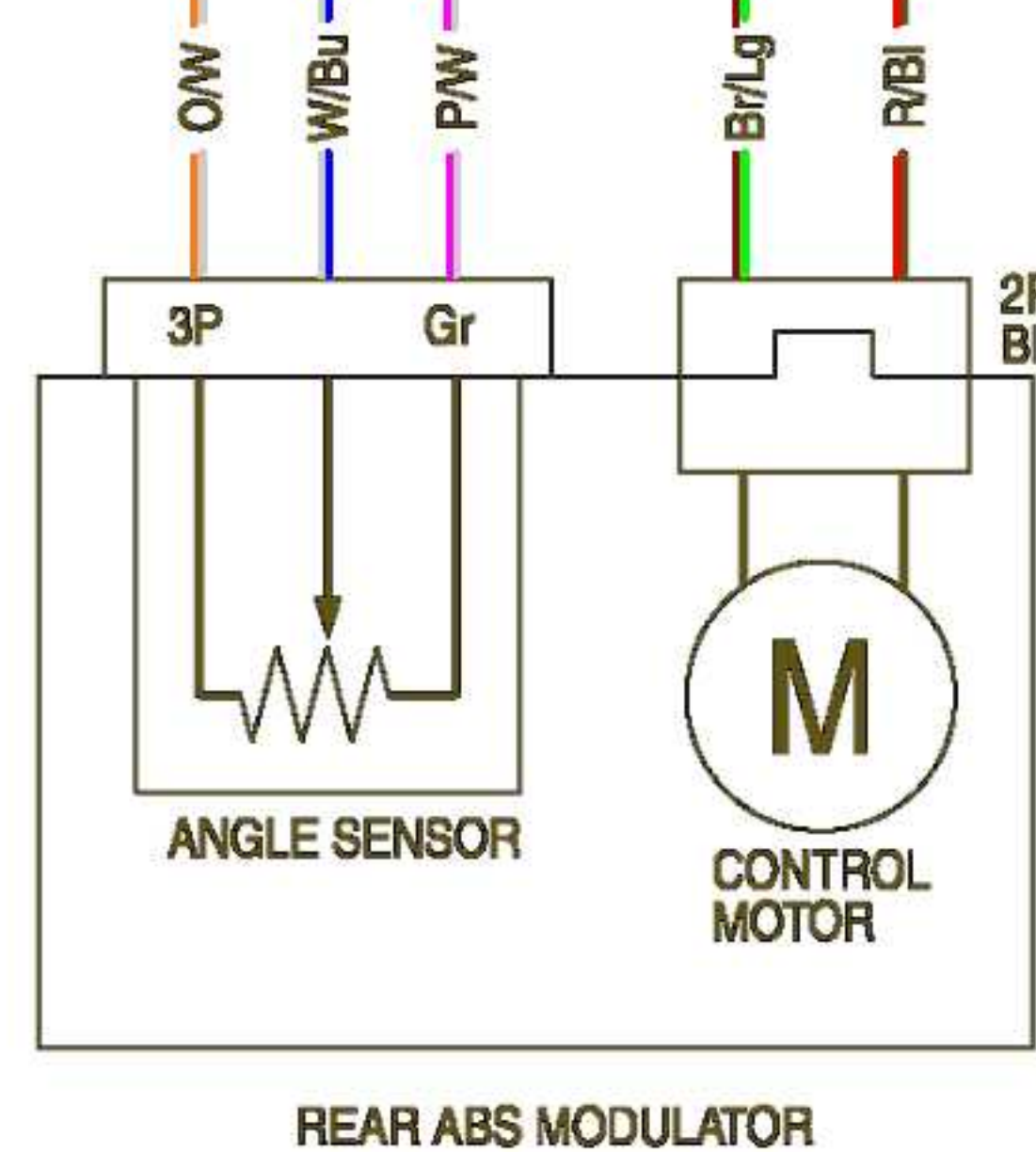
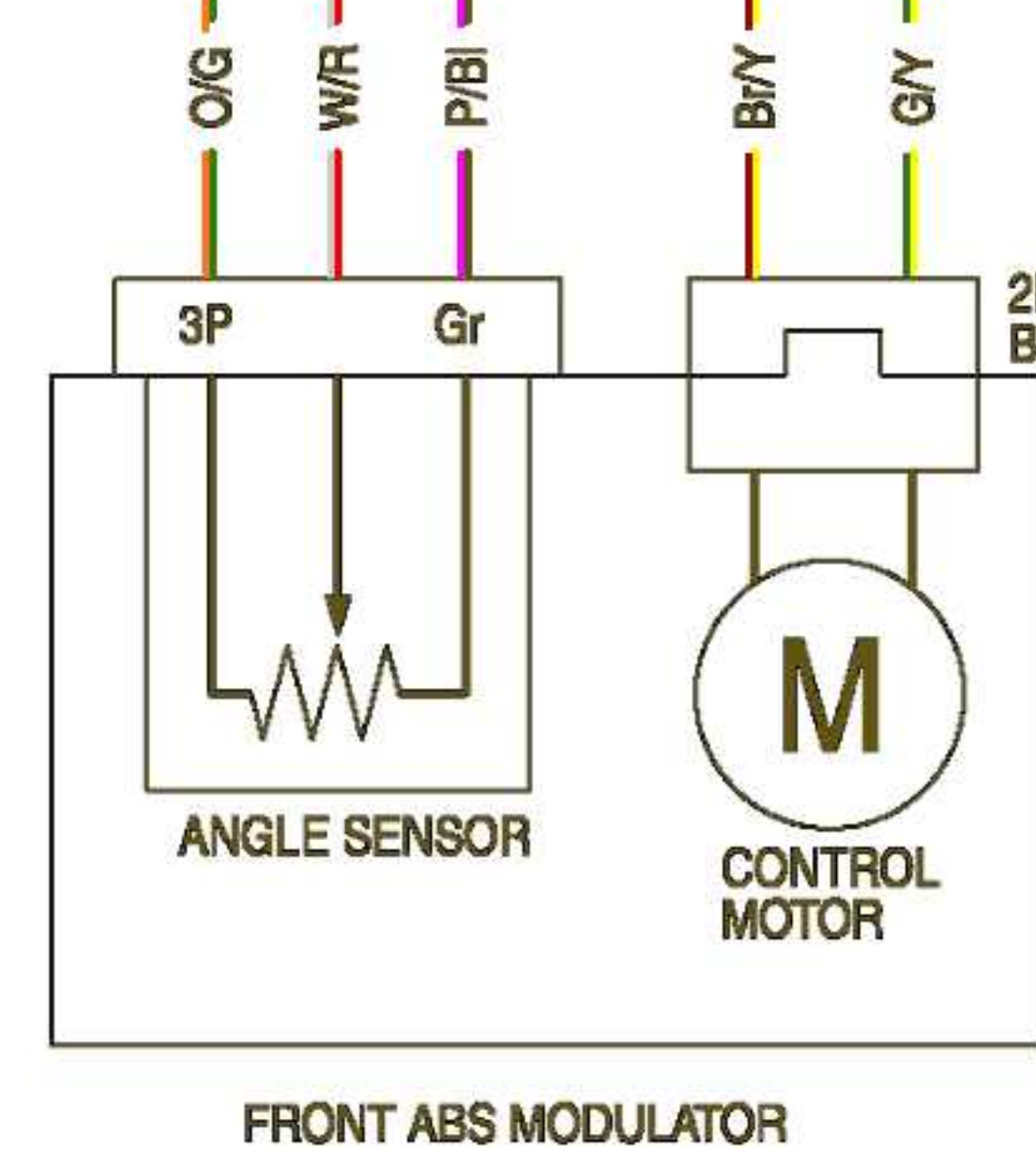
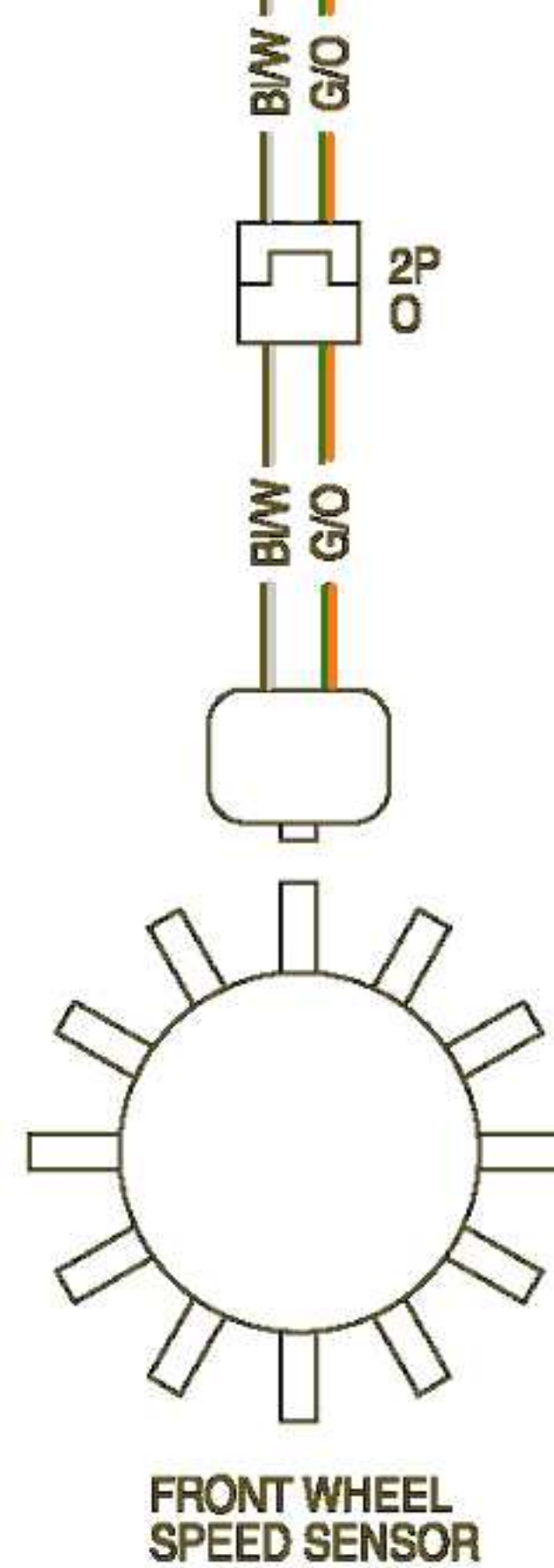
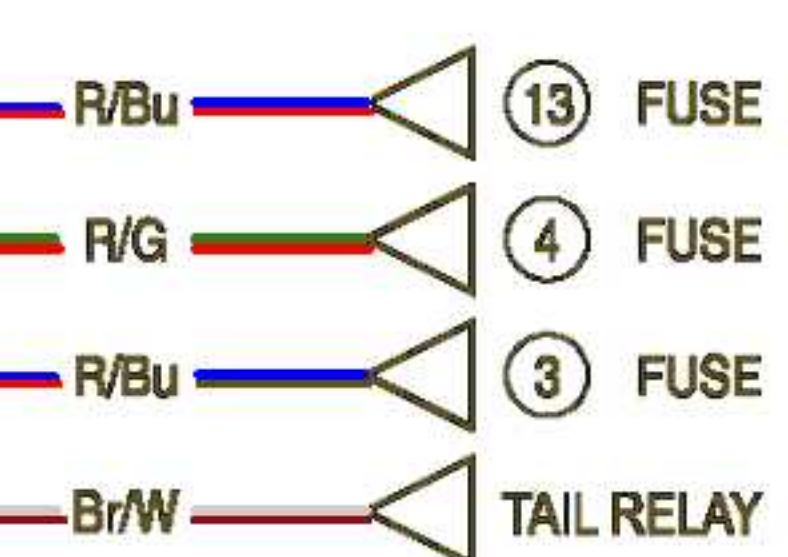
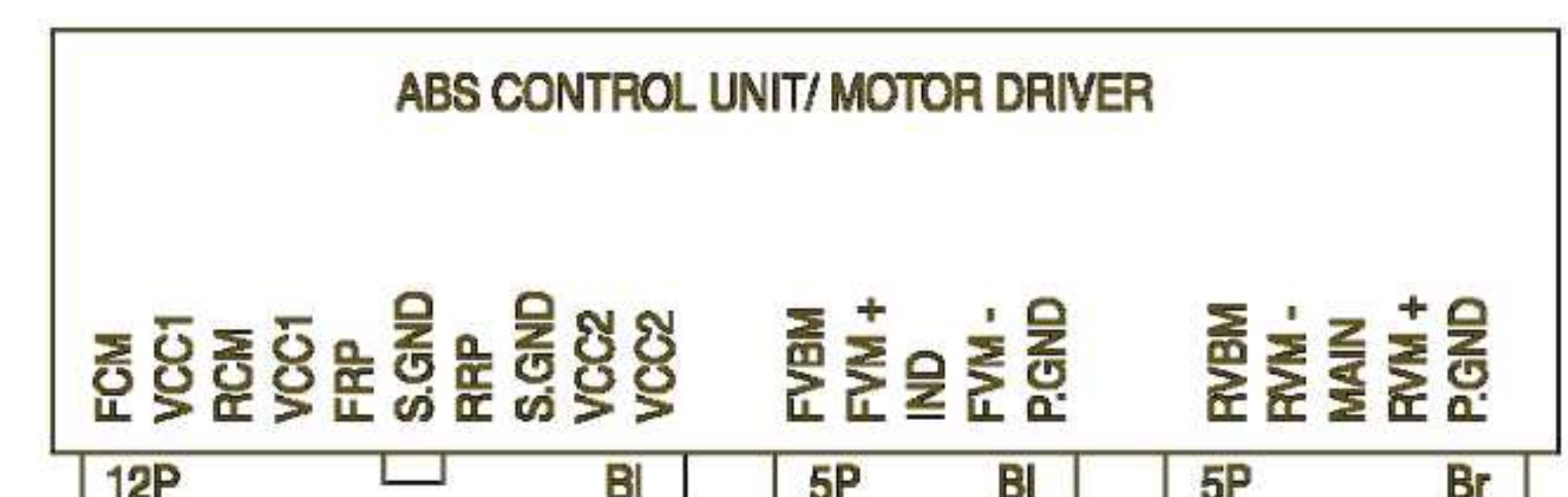
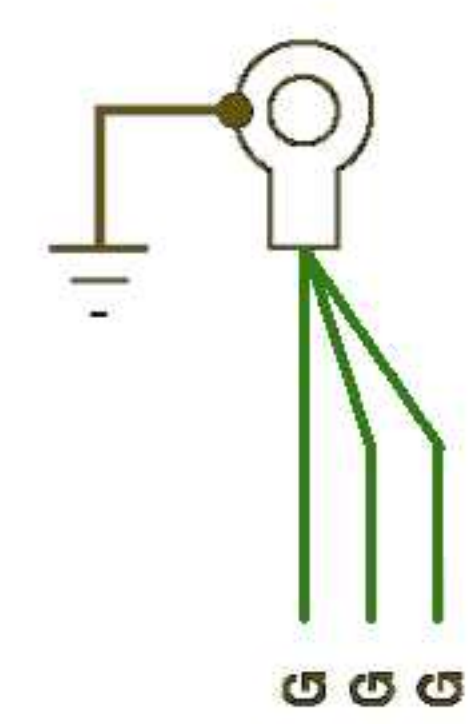
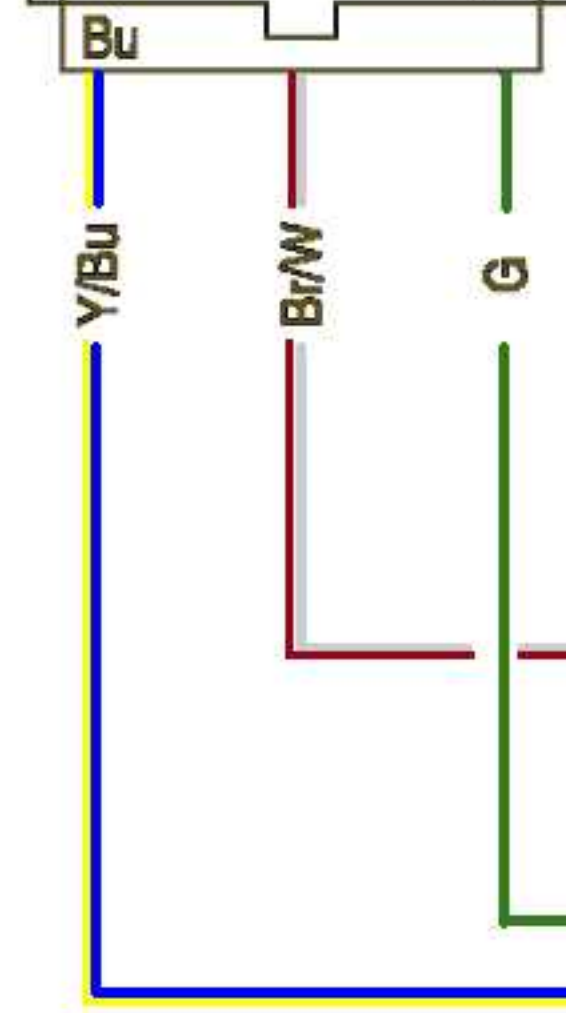
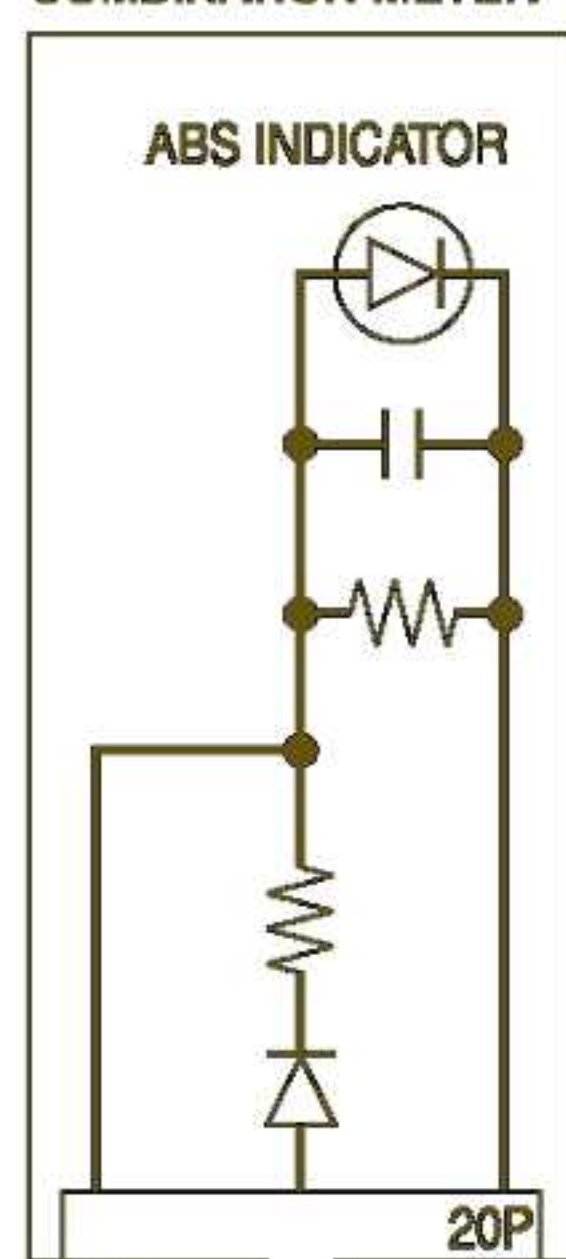



# WIRING DIAGRAM

After '01:

## COMBINATION METER

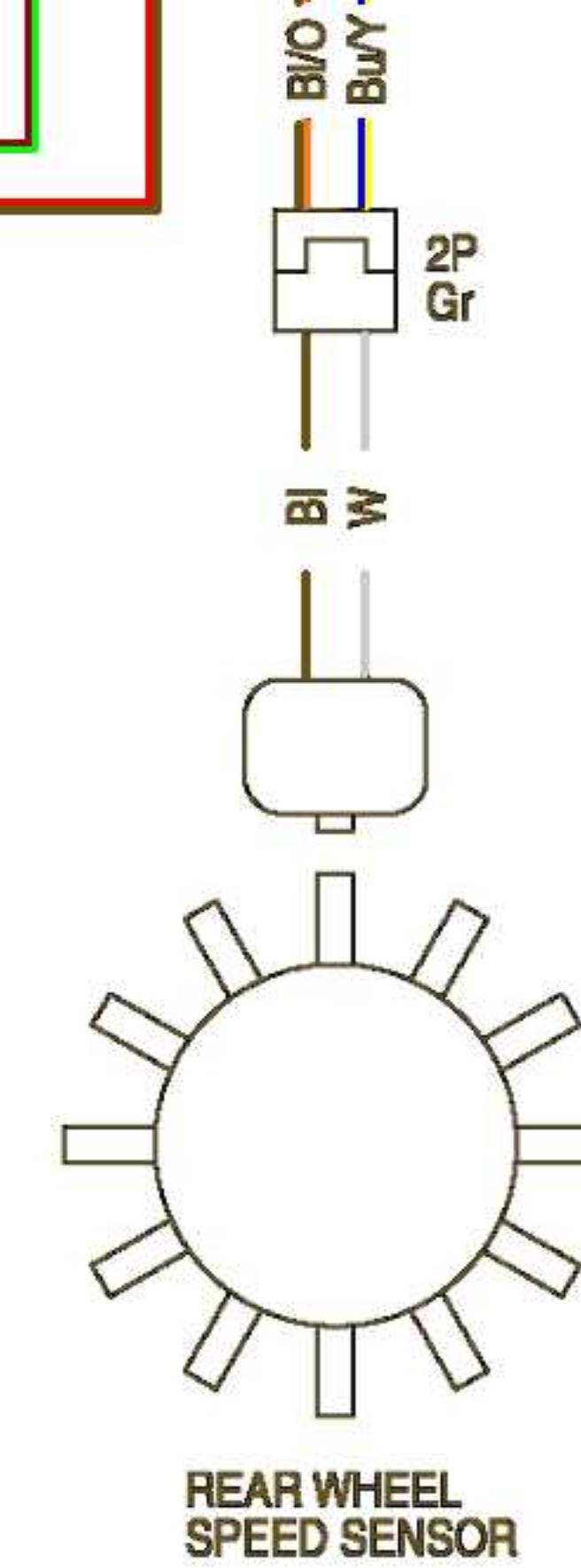
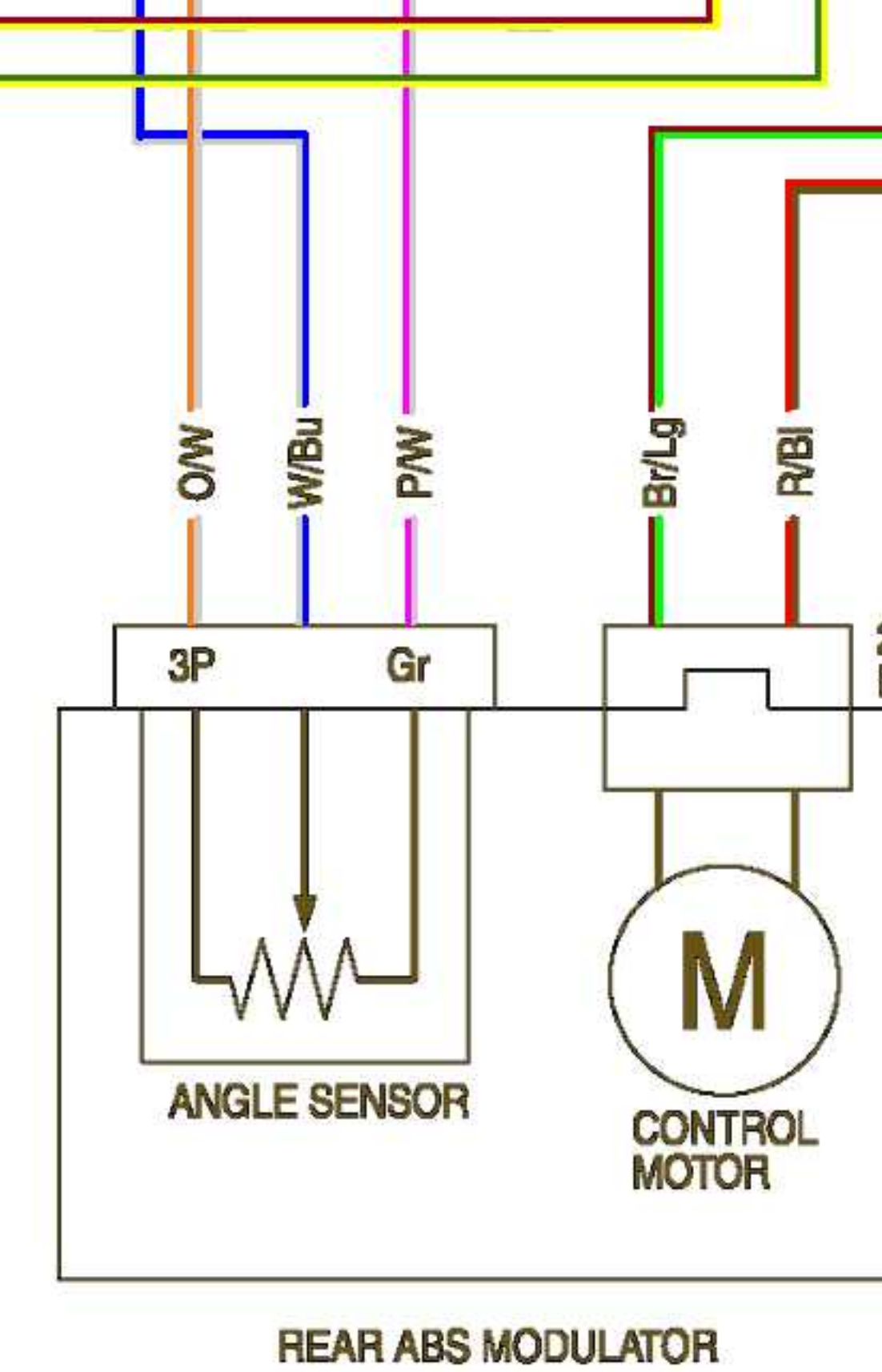
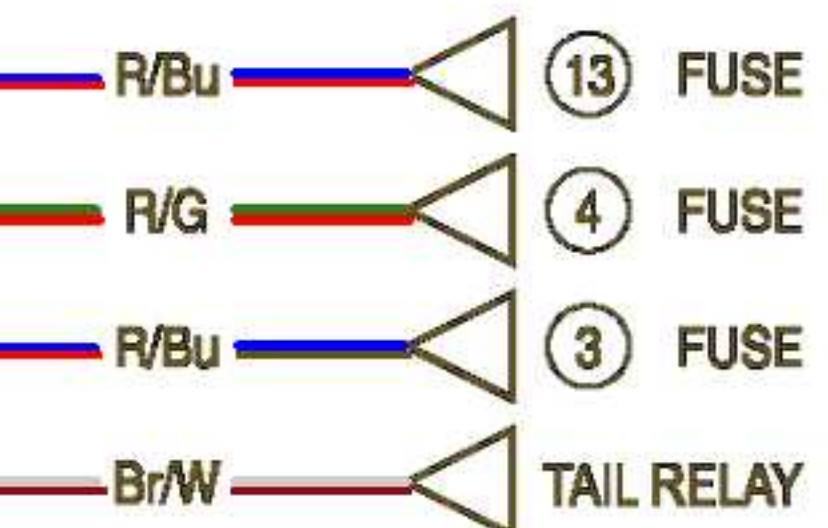
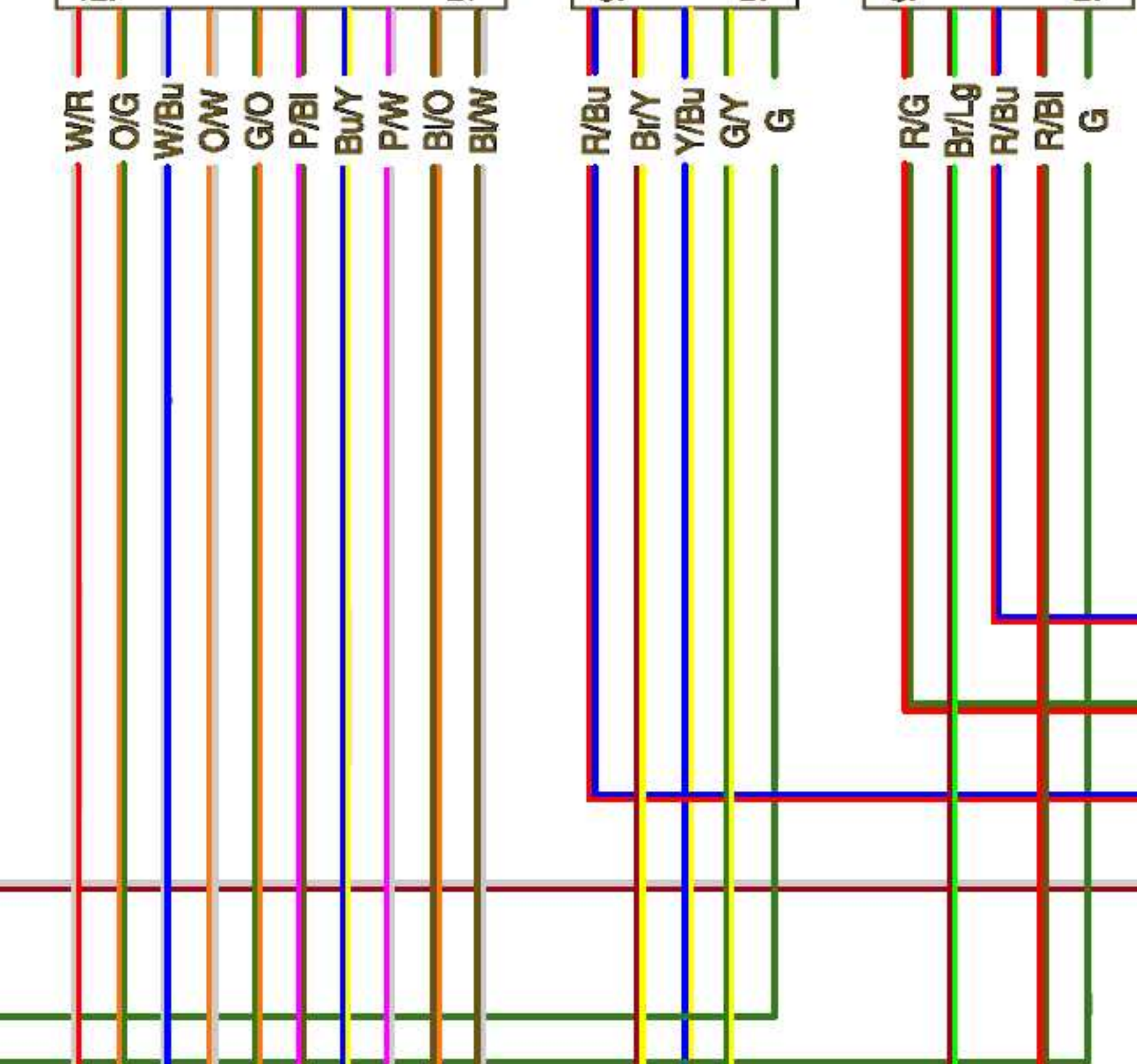
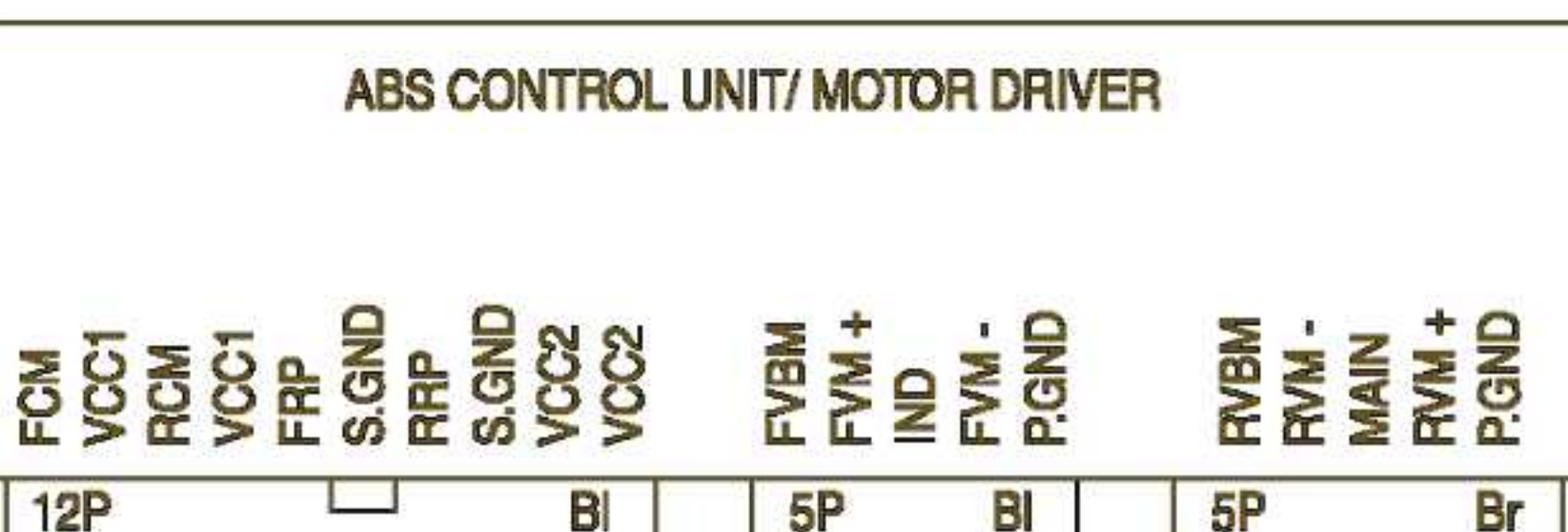
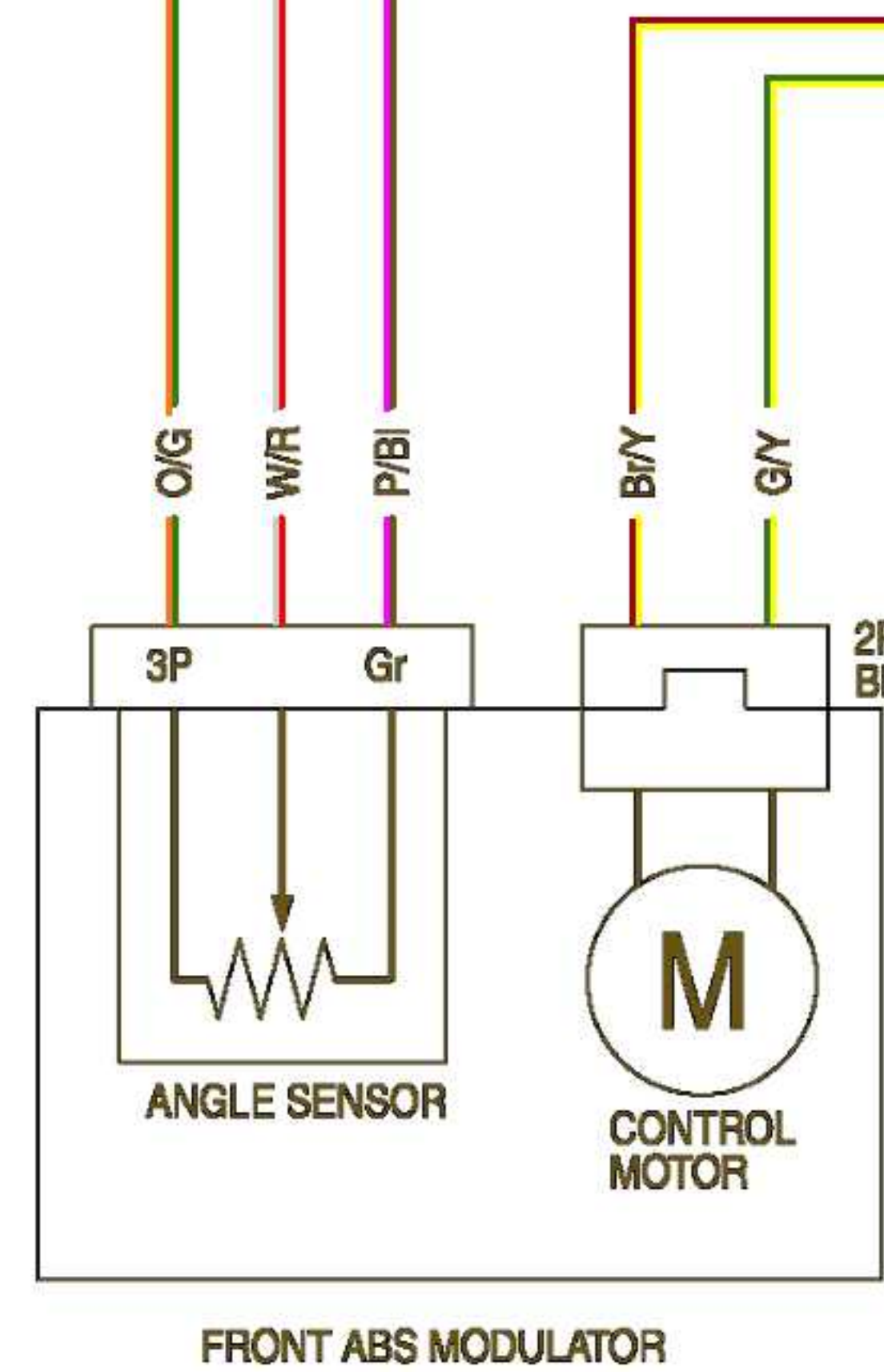
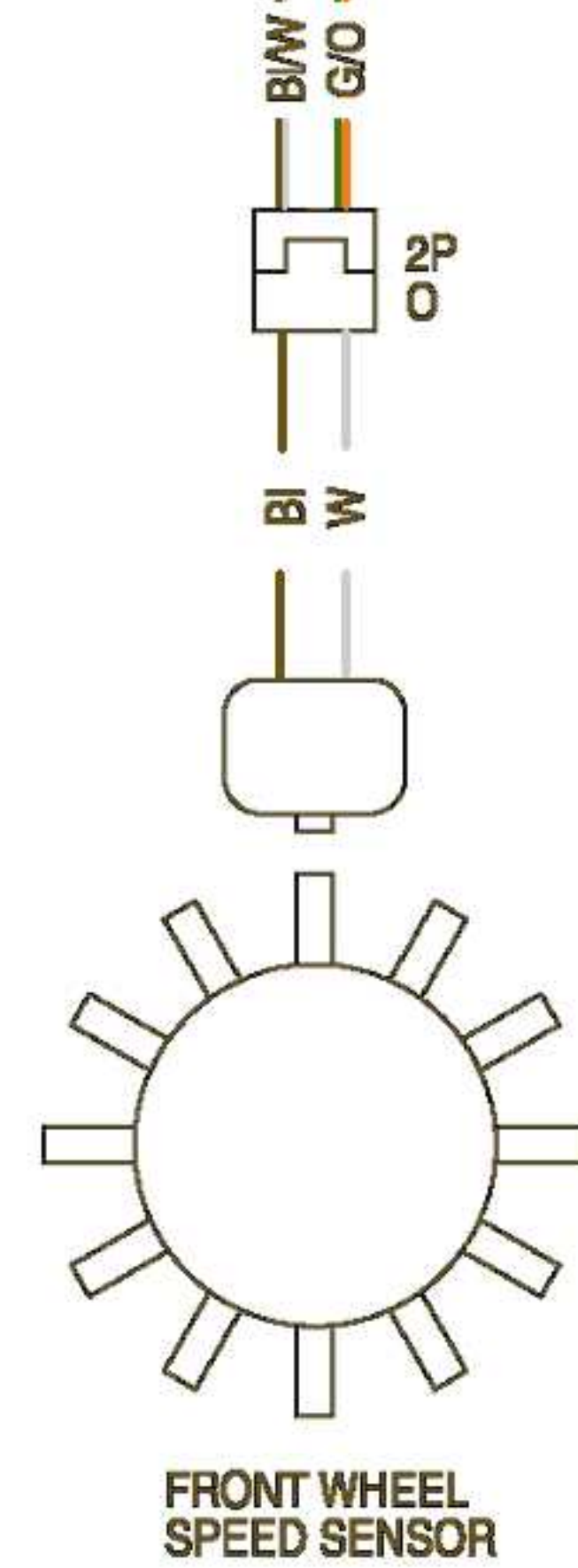
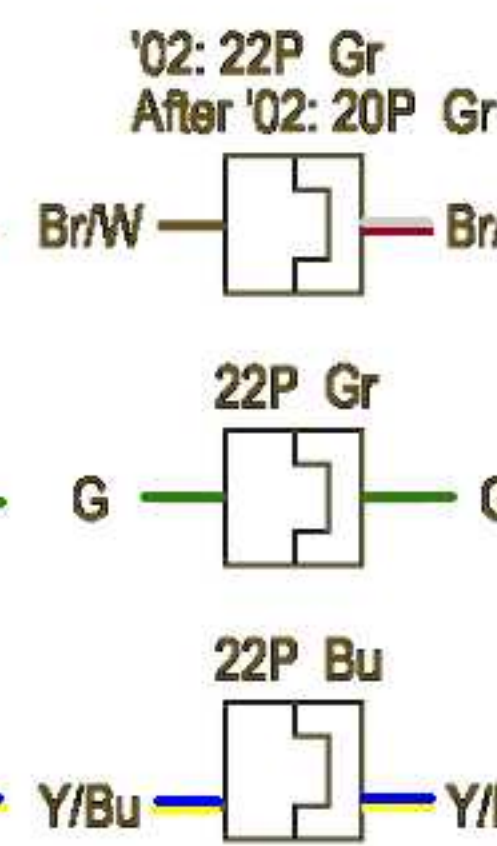
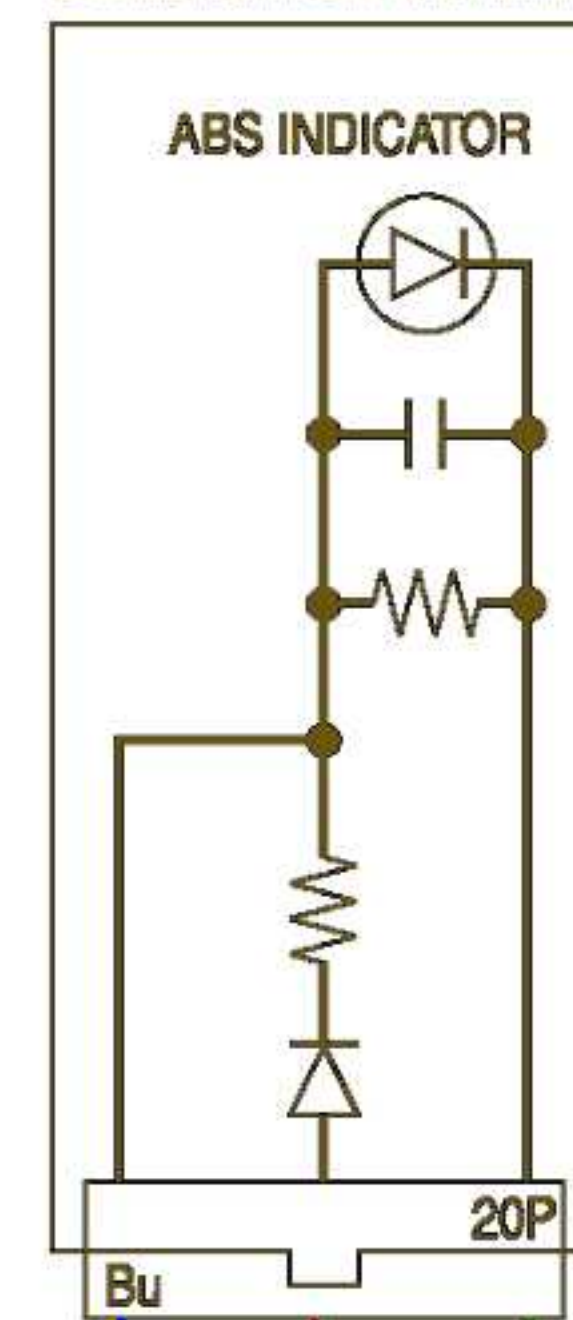



# FUEL SYSTEM (Programmed Fuel Injection)

'01 - '03:





# FUEL SYSTEM (Programmed Fuel Injection)

After '03:





# COOLING/CHARGING/IGNITION SYSTEM

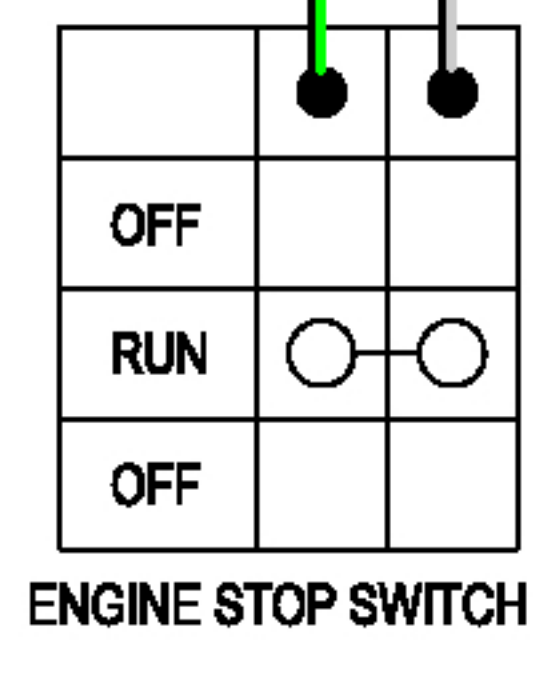
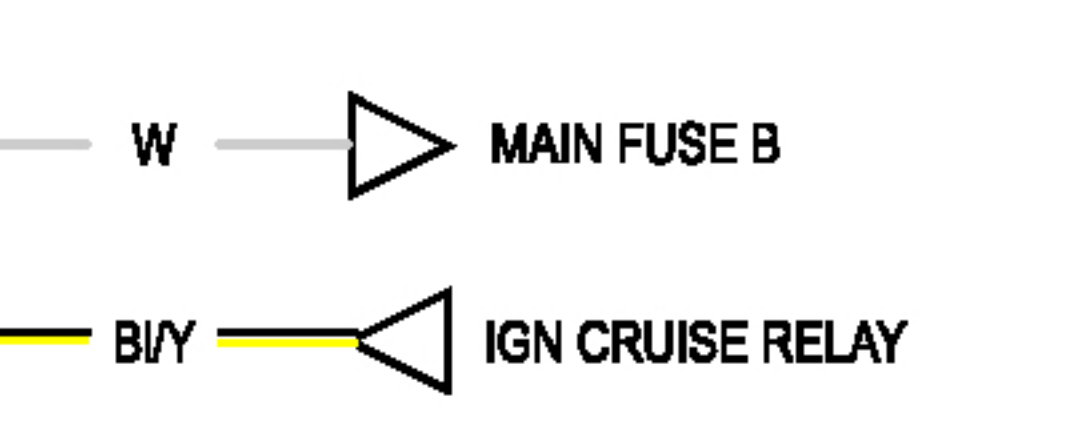
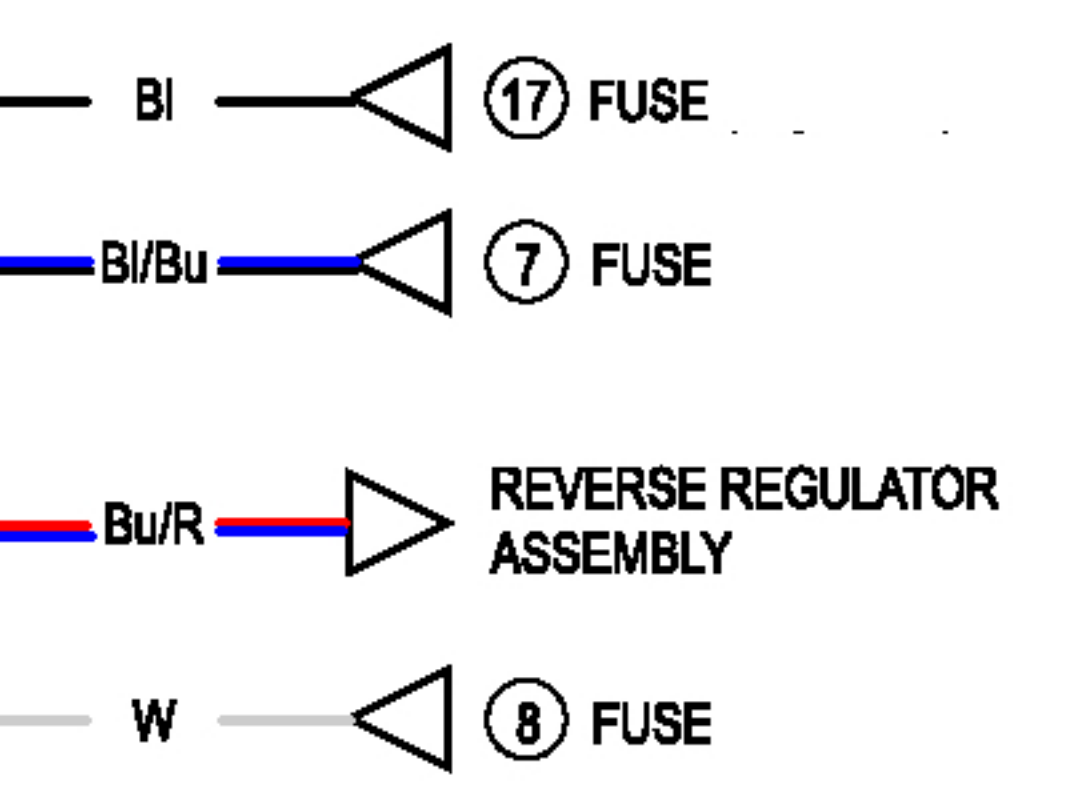
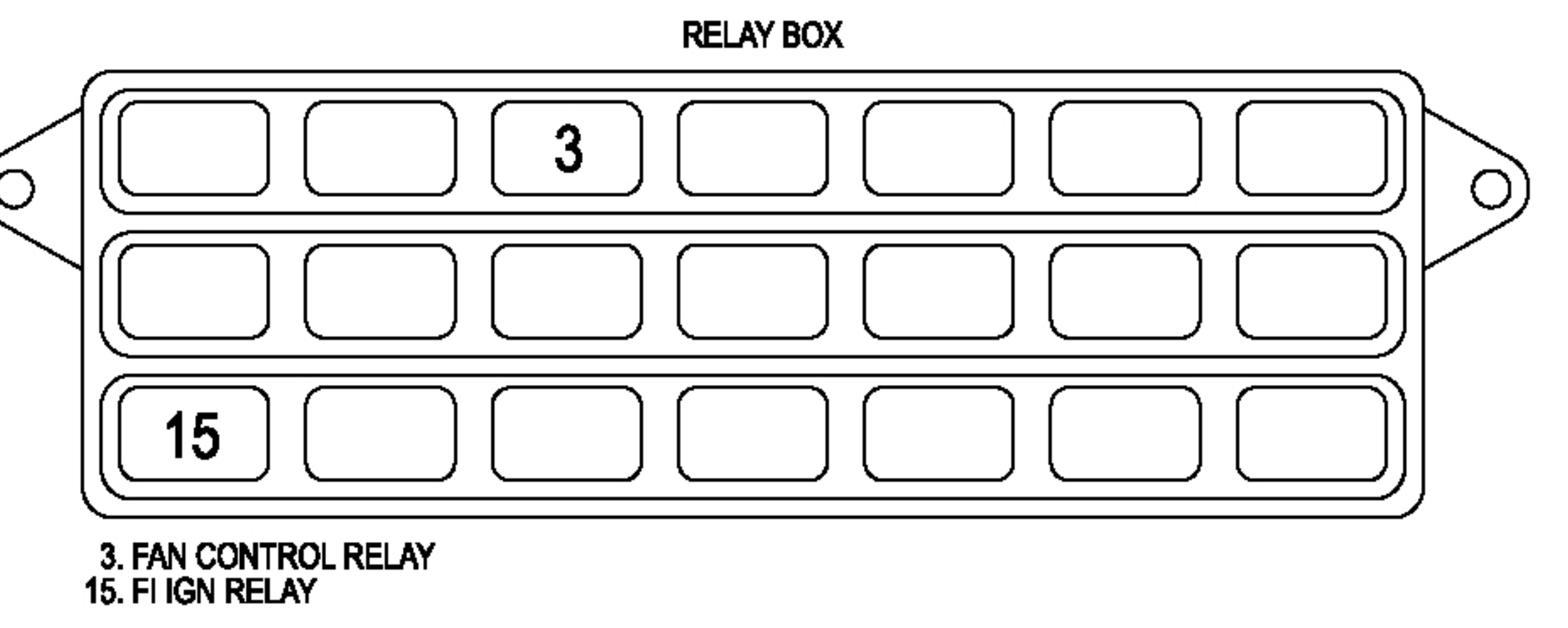




# STARTER/REVERSE SYSTEM





LIGHTING SYSTEM

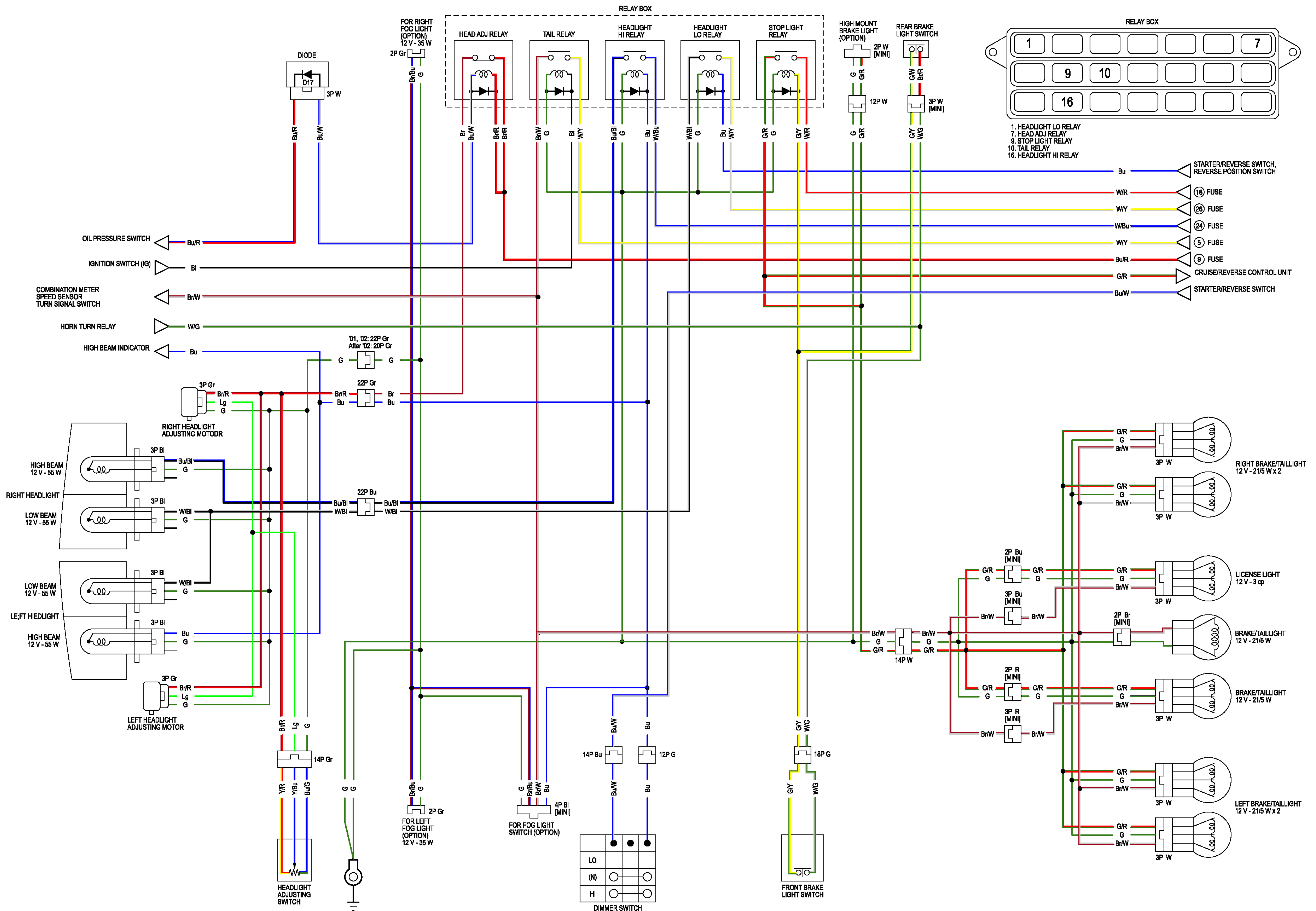



TURN SIGNAL LIGHTS/HORN





# COMBINATION METER

'01:

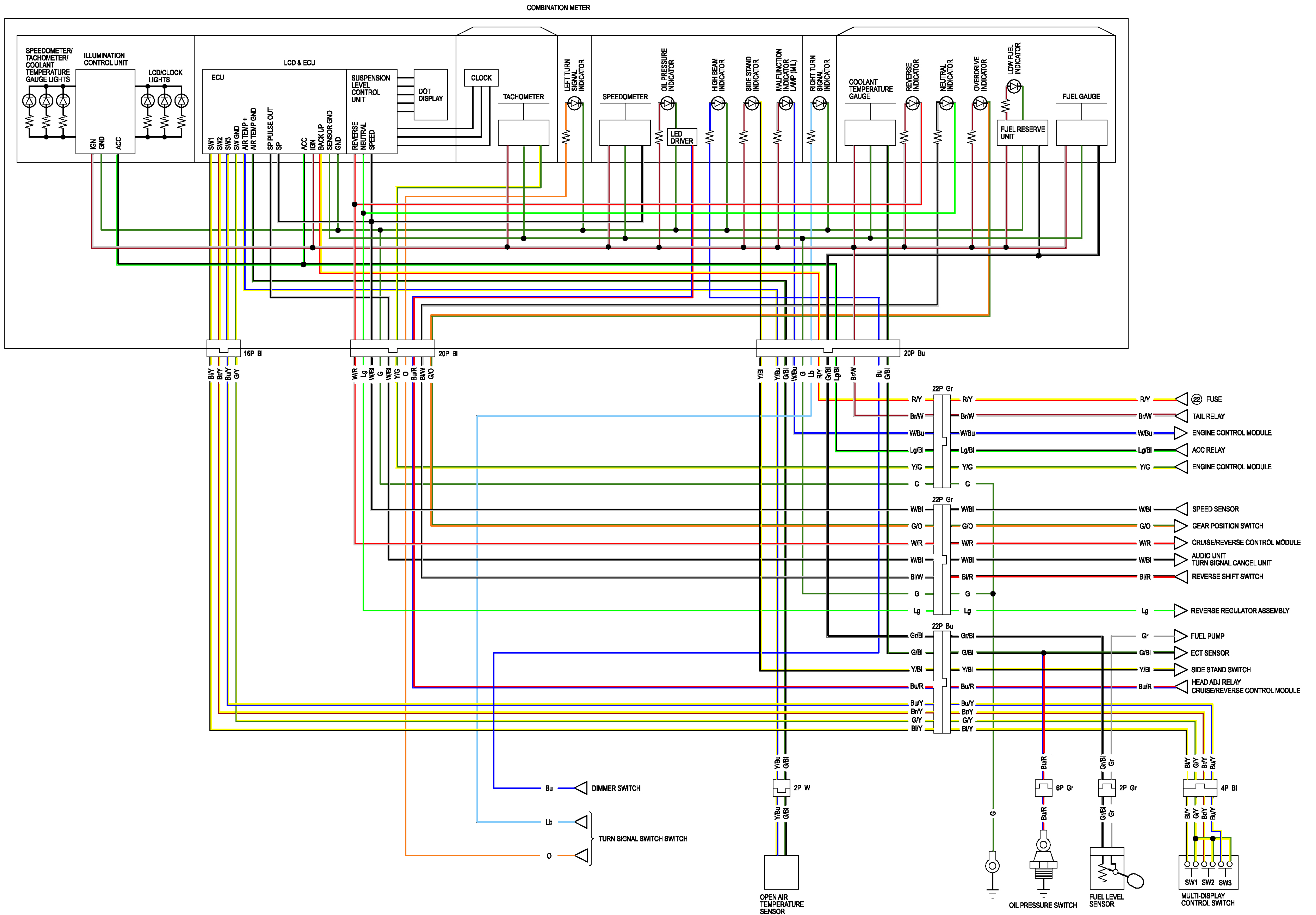



# COMBINATION METER

After '01:

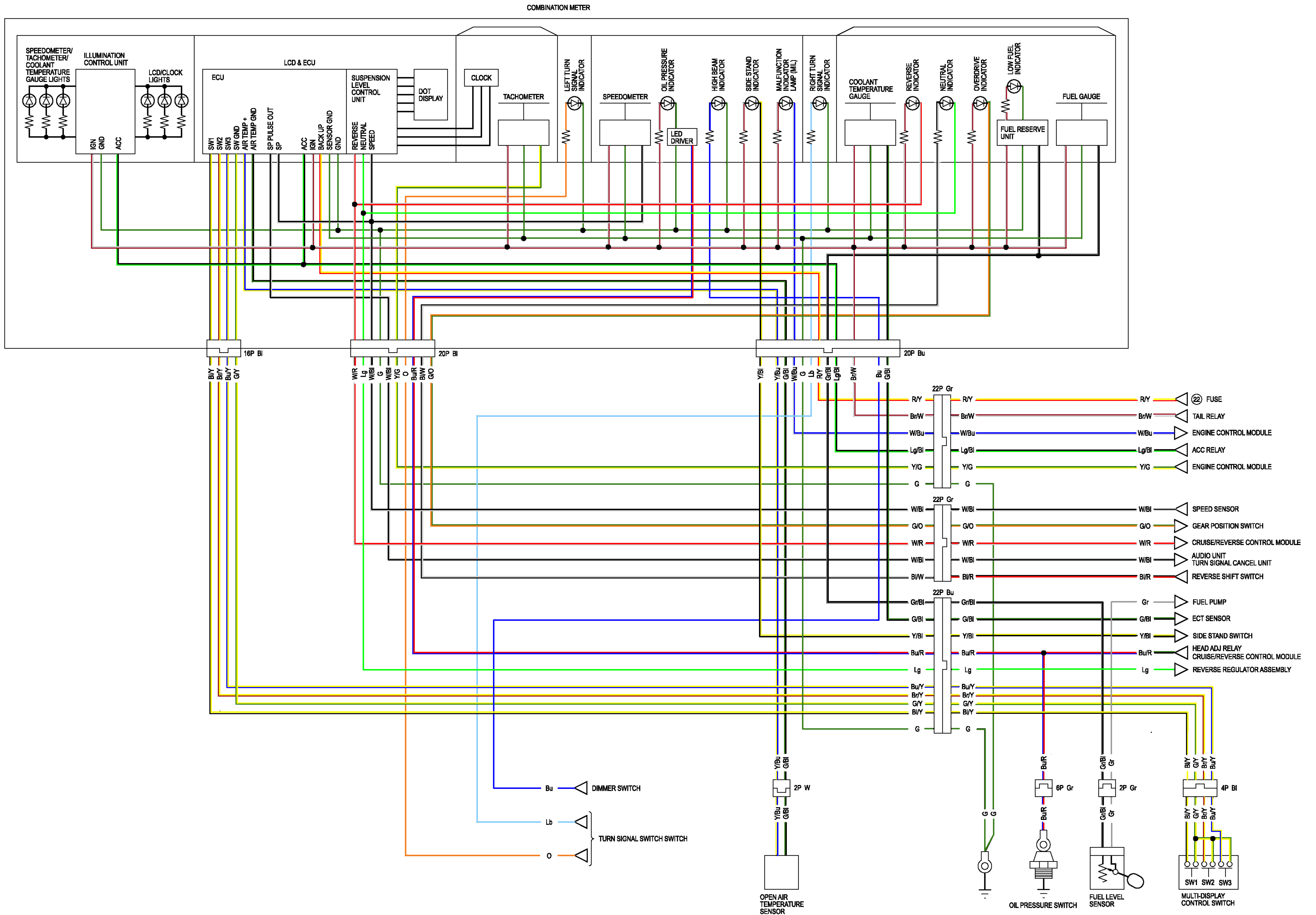



# ACC/TRUNK LOCK CONTROL SYSTEM

'01, '02:

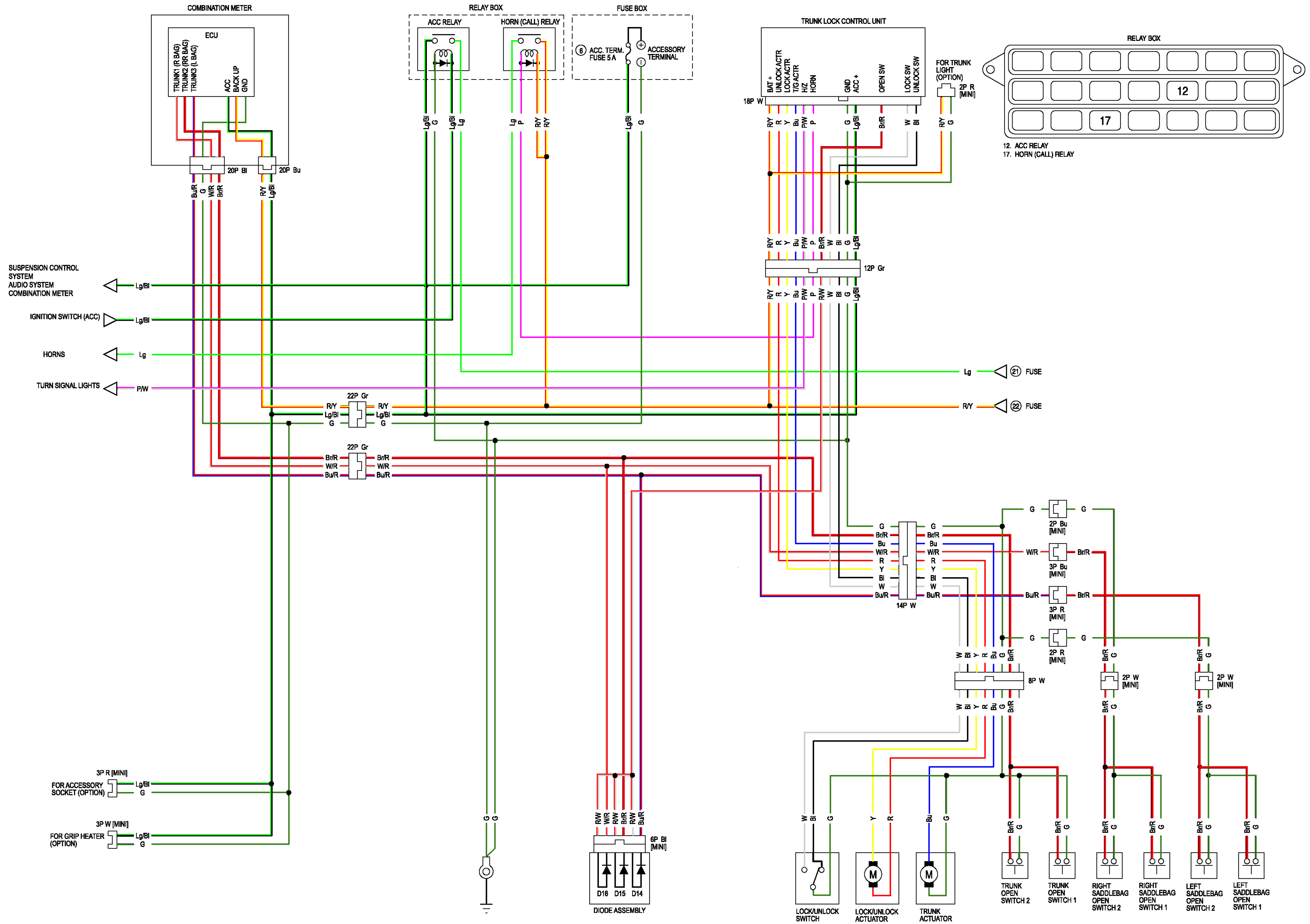

# ACC/TRUNK LOCK CONTROL SYSTEM

'03:

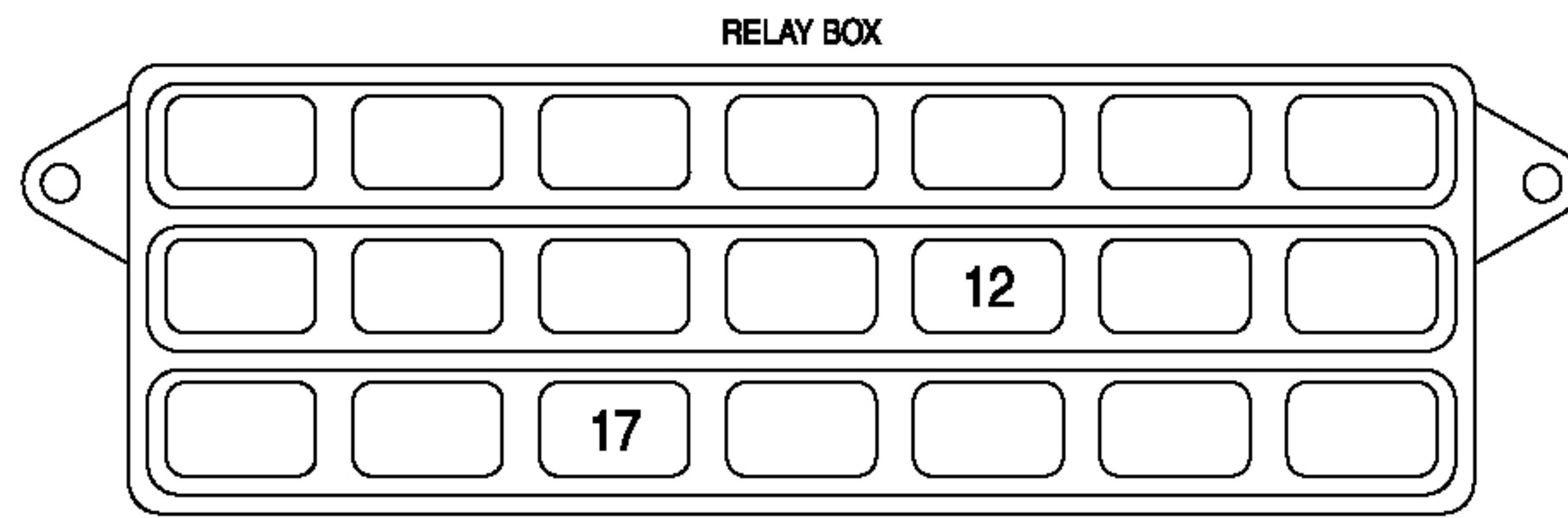
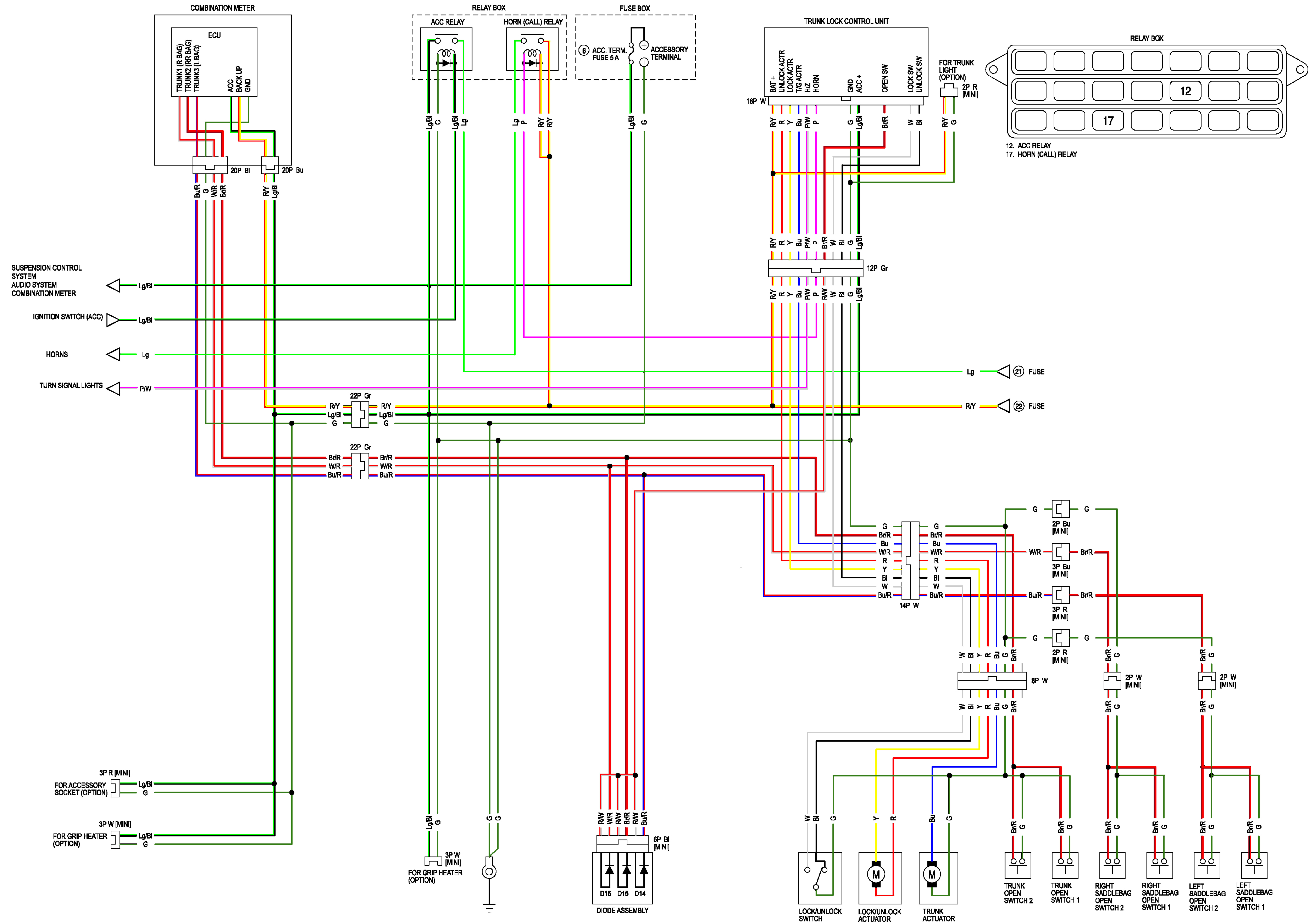



# ACC/TRUNK LOCK CONTROL SYSTEM

After '03:

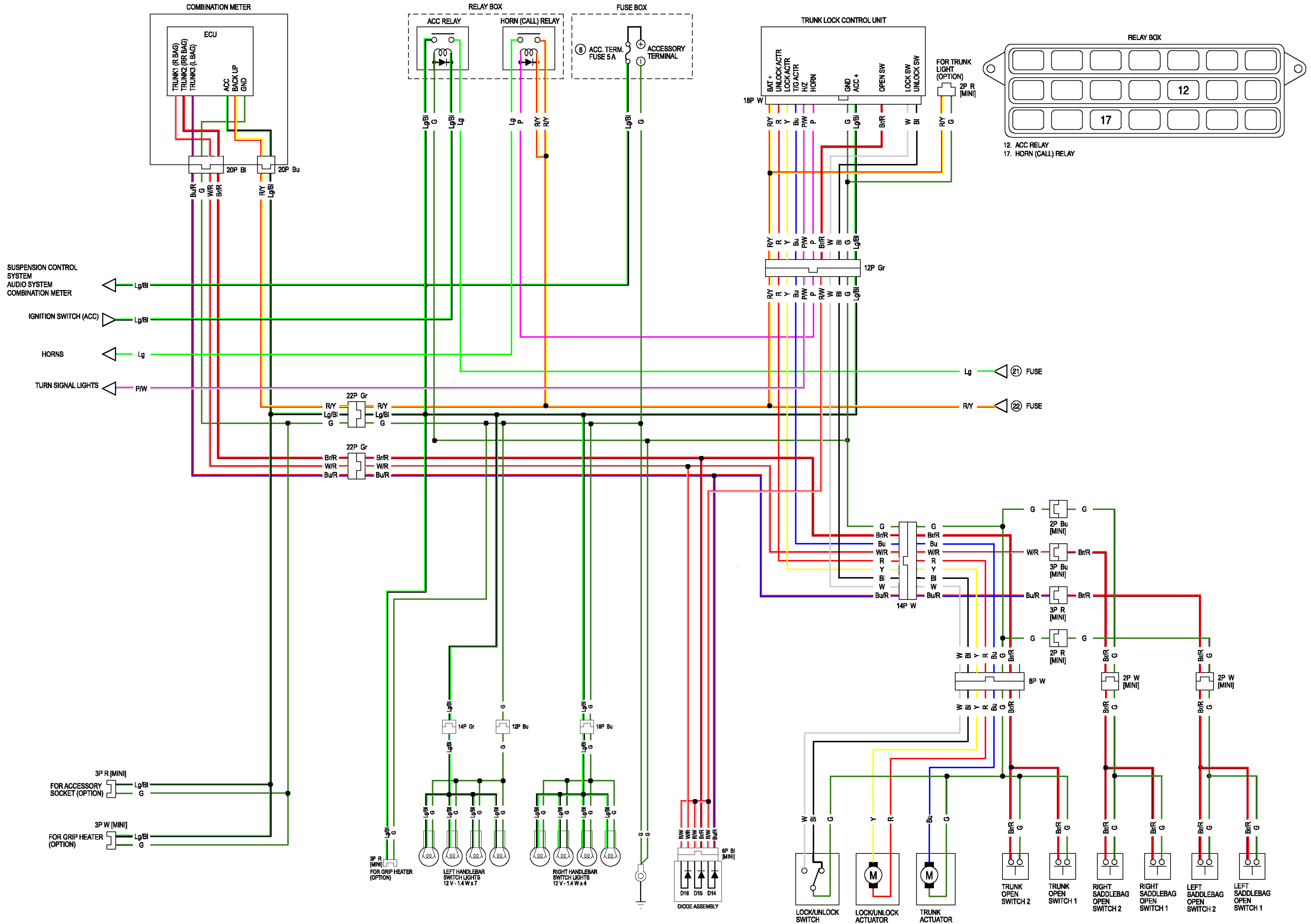



# CRUISE CONTROL SYSTEM

'01 - '03:

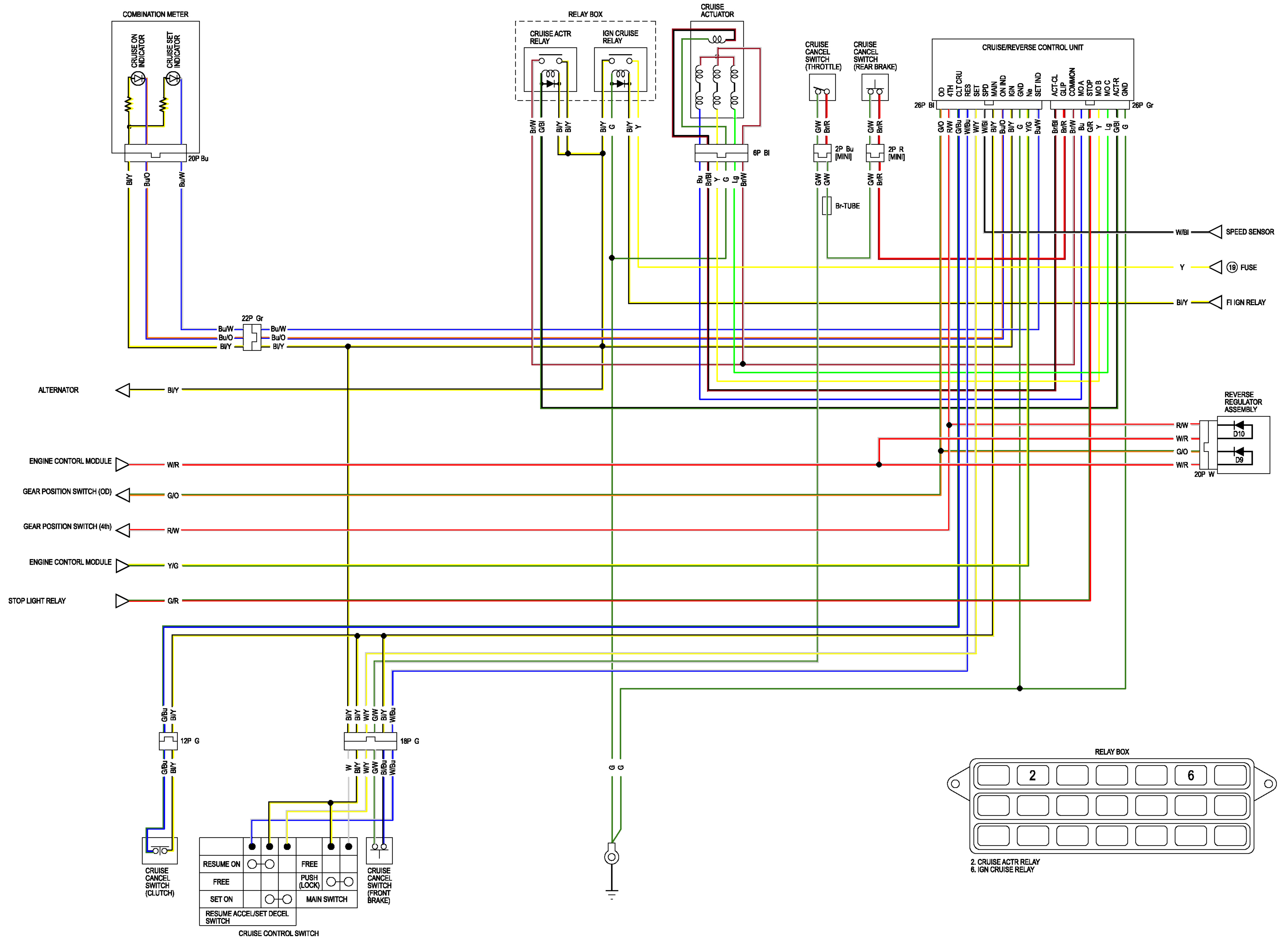

RESUME ON	○	○	FREE	○	○
FREE			PUSH (LOCK)	○	○
SET ON	○	○	MAIN SWITCH		
RESUME ACCEL/SET DECEL SWITCH					

CRUISE CONTROL SWITCH

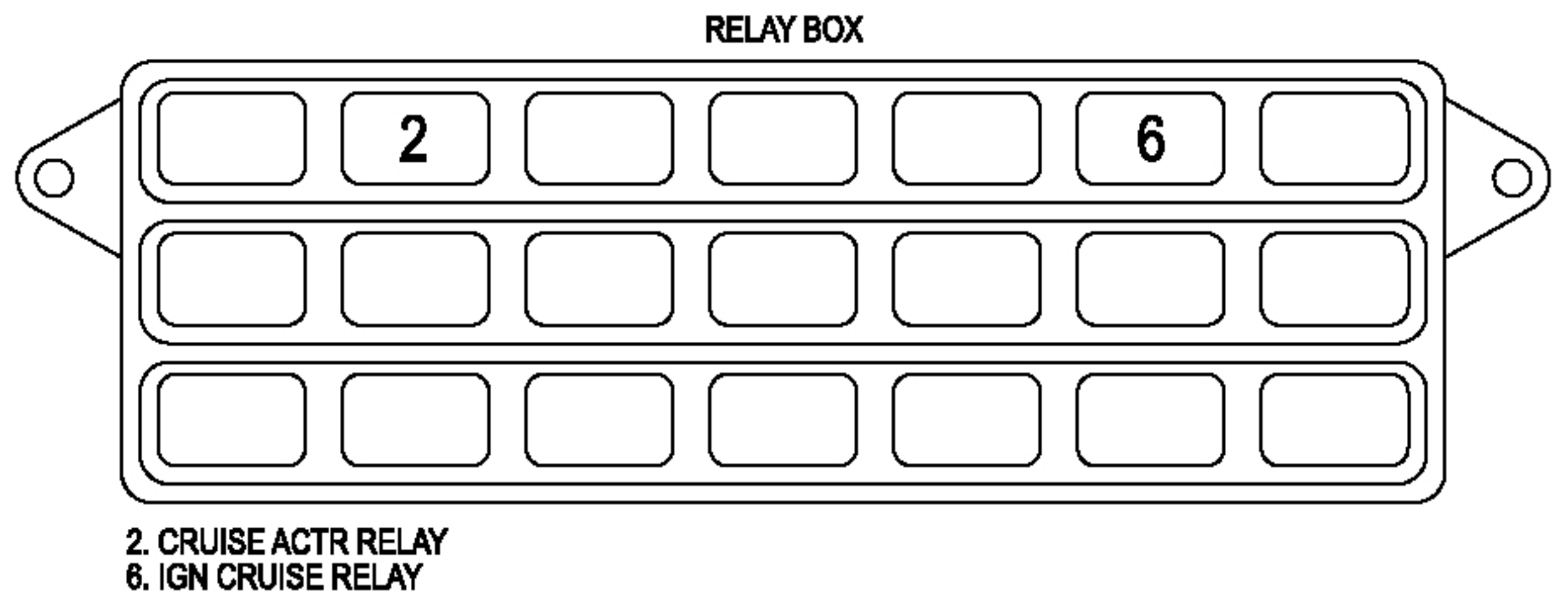

# CRUISE CONTROL SYSTEM

After '03:

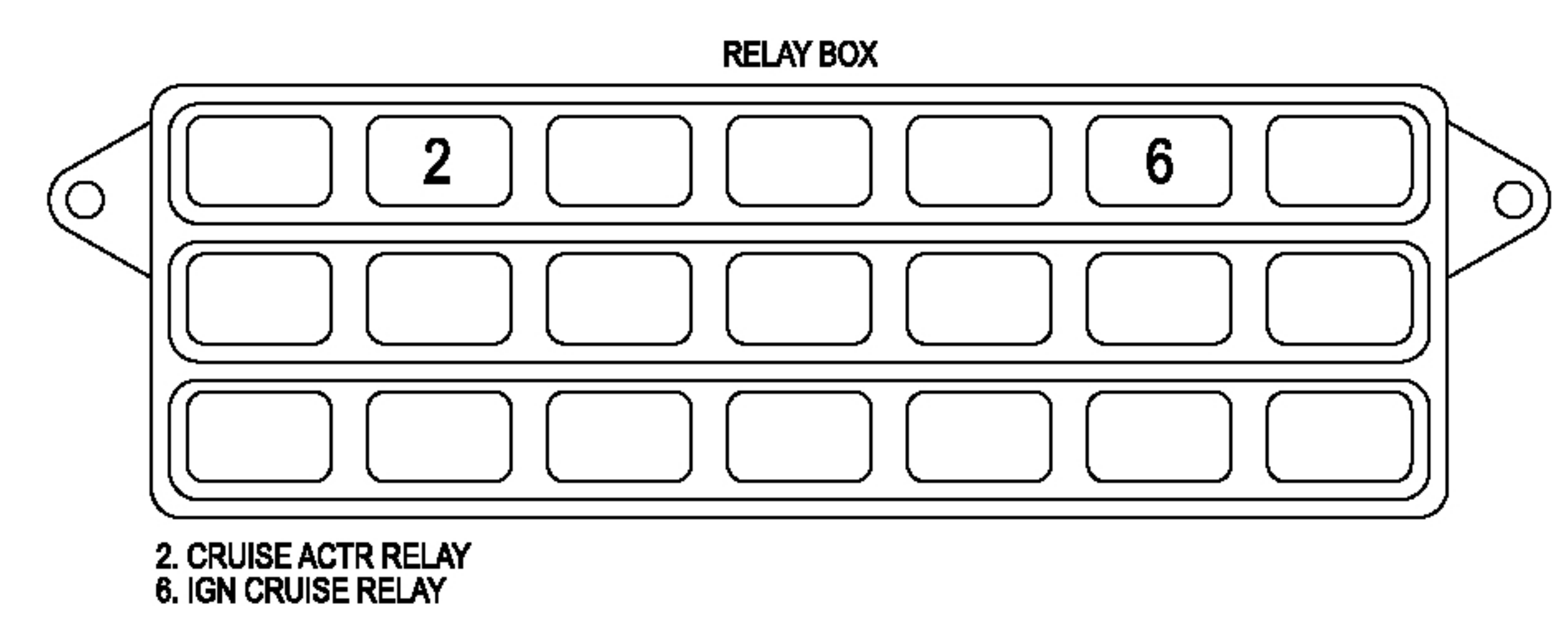
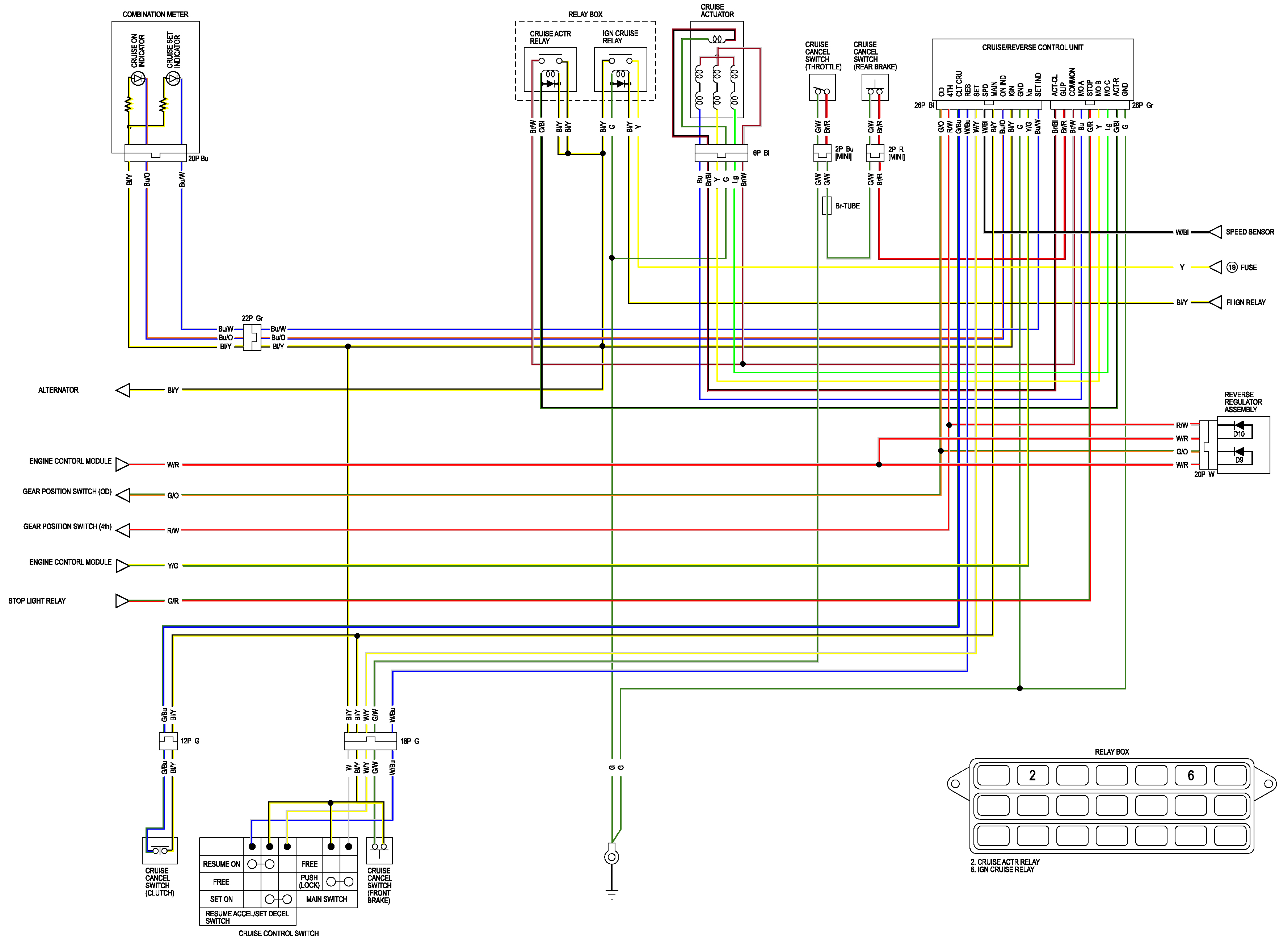



# AUDIO SYSTEM

'01, '02:





# AUDIO SYSTEM

'03:





# AUDIO SYSTEM

After '03:



# 24. TECHNICAL FEATURES

---

<b>IDLE AIR CONTROL (IAC) VALVE.....</b>	<b>24-2</b>	<b>ELECTRIC REAR SUSPENSION SPRING PRELOAD ADJUSTMENT SYSTEM.....</b>	<b>24-6</b>
<b>HYDRAULICALLY ASSISTED CLUTCH .....</b>	<b>24-4</b>	<b>ANTI-LOCK BRAKE SYSTEM (ABS).....</b>	<b>24-7</b>
<b>BRAKE SERVO-PRESSURE SENSING ANTI-DIVE SYSTEM.....</b>	<b>24-5</b>	<b>IGNITION COIL WITH BUILT-IN IGNITER ..</b>	<b>24-12</b>



## TECHNICAL FEATURES

# IDLE AIR CONTROL (IAC) VALVE

### SUMMARY

The IAC valve is the electro-magnetic variable valve that controls the idle speed of the engine by passing air around the throttle valves when they are fully closed. It controls the fluctuation of the idle speed and adjusts it to the basic idle speed by supplying air to the intake manifold according to the engine coolant temperature, engine load, and the condition of the throttle valves. When the coolant temperature is low, the IAC valve functions as the fast idle valve, too.

### STRUCTURAL PRINCIPLE

As the IAC valve shaft rotates, the IAC valve opens and closes the air passage to control the air flow volume.

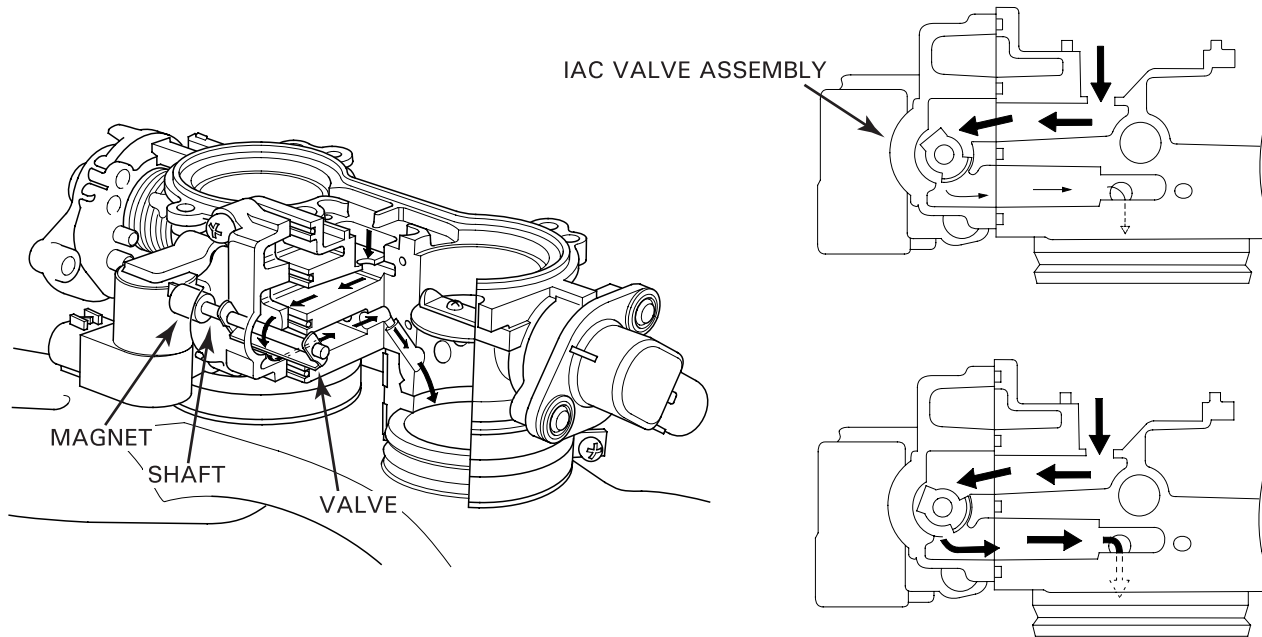

A magnet is mounted at the end of the shaft, i.e., in the oval hole in the iron core. Because the magnet is set at the center of the oval hole, the magnetic force from the N-pole and the S-pole attracts the iron core of the narrowest air gap part to the magnet, bringing the magnet to the position shown. The iron core is wound with a coil. Therefore, it turns into an electro-magnet when electric current flows through the coil.

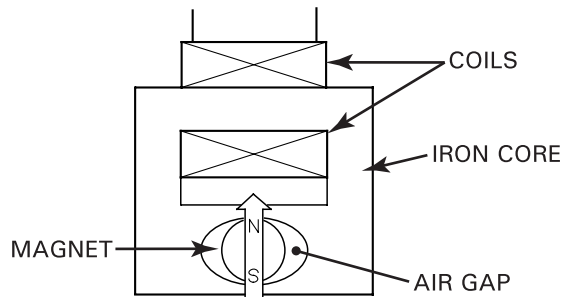

When electric current flows through the coil turning the iron core into an electro-magnet, the N and S poles of the magnet and the N and S poles of the electro-magnet attract each other causing the magnet on the valve shaft to rotate. To change the rotating direction of the valve, current flow is reversed. This switches the N and S poles of the electro-magnet and the rotating direction of the valve reverses.

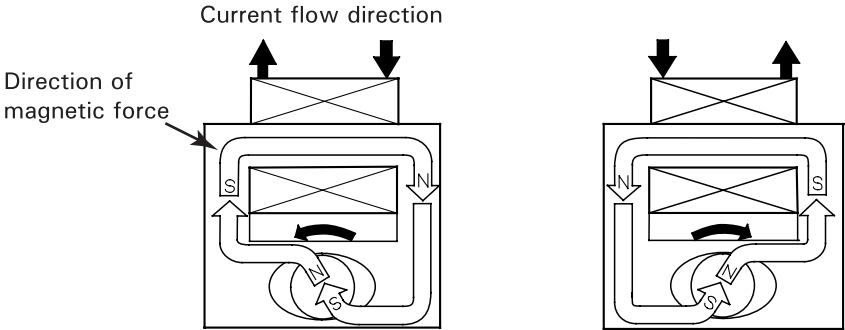

**OPERATION CONTROL**

The IAC's drive signal is output from the ECM to turn the IAC valve side voltage on and off. As the IAC valve is required to control the intake air flow volume by continuously changing its valve angle, the digital drive signal turns the voltage on and off at a constant frequency, with the signal being a PWM (Pulse Width Modulation) type that changes the on time ratio per cycle. This is referred to as the duty ratio (duty cycle). The average current changes smoothly, just as the analog type does, in accordance with the changes of the duty ratio. The IAC valve has a built-in drive circuit. With the 50% of the duty ratio used as a reference point of 0 (zero), the drive circuit judges the duty ratio below the reference point as the close-circuit direction and the duty ratio (duty cycle) above the reference point as the open-circuit direction. The IAC switches the open and close circuit direction by changing the direction of the current flow through the coil.

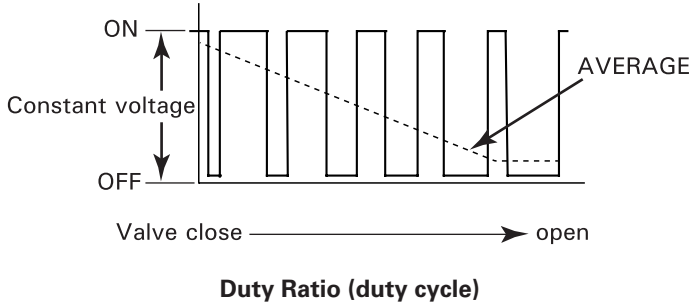
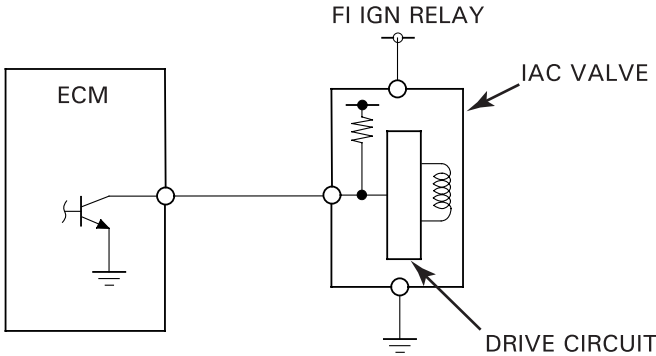

## TECHNICAL FEATURES

# HYDRAULICALLY ASSISTED CLUTCH

### SUMMARY

The hydraulically assisted clutch uses engine oil to boost the engagement force against the pressure plate. This clutch increases the friction force between the clutch plates and discs (pressure force against the pressure plate) without the need for heavy clutch springs. This allows the use of a small and lightweight clutch, which results in a light clutch lever feel.

High pressure oil is pumped from the oil pump through the crankcase oil passage. Oil flows through the oil passage and is regulated by the regulator valve. The oil then travels through the oil passage in the clutch cover and joint piece, and goes to the clutch.

### CONSTRUCTION AND OPERATION

#### When the clutch is engaged:

The pressurized oil flows through the oil passage in the joint piece and mainshaft, and enters an oil chamber which is formed by the clutch piston, pressure plate, and clutch center. Because the clutch piston and clutch center are fixed by the lock nut via the spring guide, oil pressure moves the pressure plate towards the clutch center.

The clutch spring is forced against the pressure plate via lifter plate B. Therefore, the clutch plates and discs are pressed together by oil pressure and spring force.

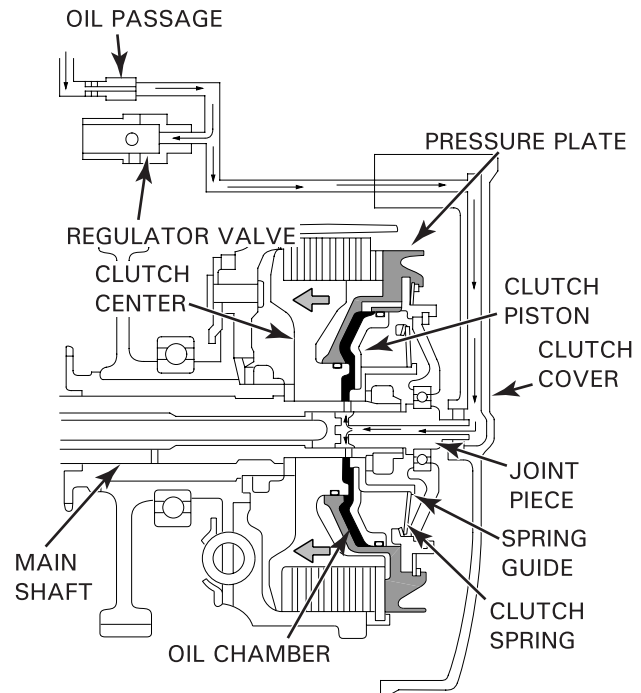

#### When the clutch is disengaged:

The oil outlet ports in the pressure plate are sealed by lifter plate B. Lifter plate B is pressed against the pressure plate by the force of the clutch spring. When lifter plate A is pushed out by the lifter rod via the joint piece and bearing, the spring force, which acts on the pressure plate via lifter plate B, is released.

This opens the outlet ports sealed by lifter plate B and oil pressure in the oil chamber is released. Therefore, oil pressure and spring force are removed, the friction force between the clutch plates and discs is relieved, and the clutch is disengaged.

The lifter spring presses lifter plate B against the pressure plate lightly to prevent the oil in the chamber from leaking.

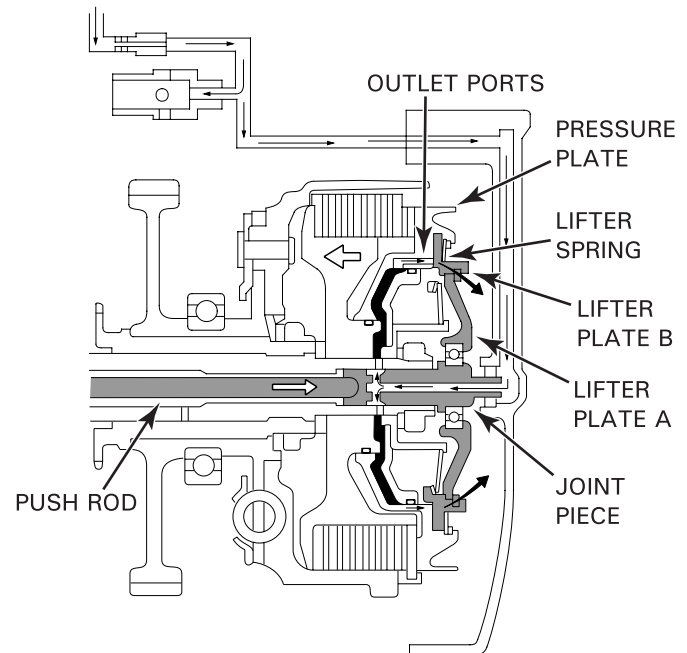

# BRAKE SERVO-PRESSURE SENSING ANTI-DIVE SYSTEM

This motorcycle is equipped with the Linked Brake System (LBS). This system operates the anti-dive system on the left front fork by utilizing fluid pressure generated in the secondary master cylinder. The secondary master cylinder responds to braking forces generated by the lever and/or pedal. When either brake is applied, the plunger is pushed by pressure from the secondary master cylinder and the anti-dive piston valve in the fork oil passage moves to block the passage. As the flow of the fork fluid is reduced by movement of the piston valve, the system reduces compression of the front fork and thereby controls the nose dive of the vehicle.

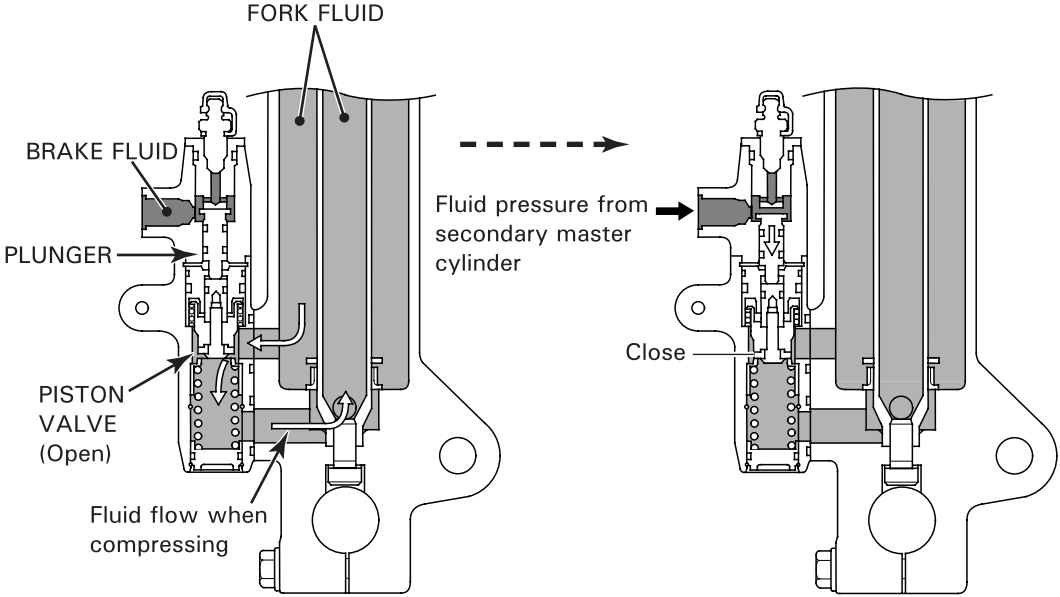
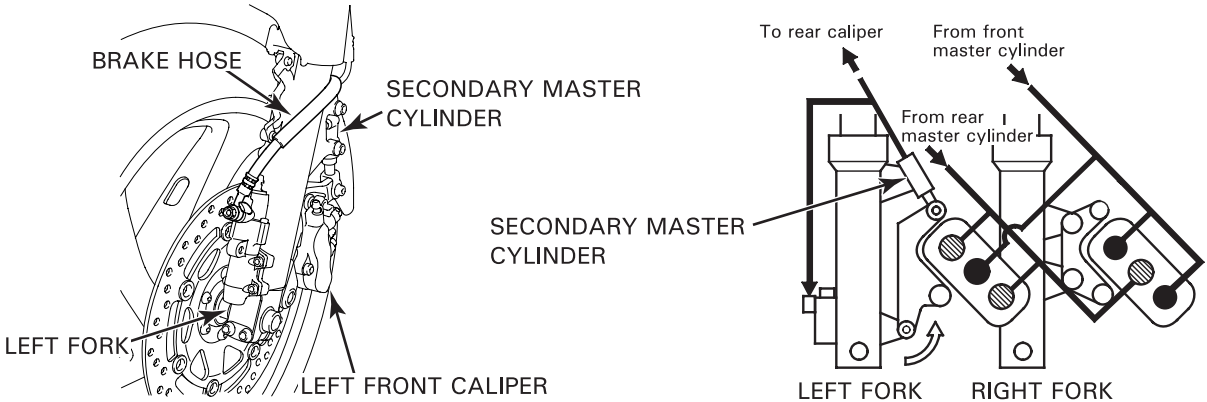

## TECHNICAL FEATURES

# ELECTRIC REAR SUSPENSION SPRING PRELOAD ADJUSTMENT SYSTEM

This system adjusts the rear suspension spring preload by operating a hydraulic jacking system that is driven by an electric motor.

The shock absorber and actuator are connected with an oil hose. The piston in the actuator is operated by the control motor, while the shock absorber piston is operated by hydraulic pressure. The piston stroke is detected by the angle sensor and the motor is controlled with the control unit (ECU) inside the combination meter.

Preload can be adjusted by operating the "Up" and "Down" switch while monitoring the preload condition on the multi-display. Two preload settings can be stored and retrieved by operating the memory buttons on the control panel.

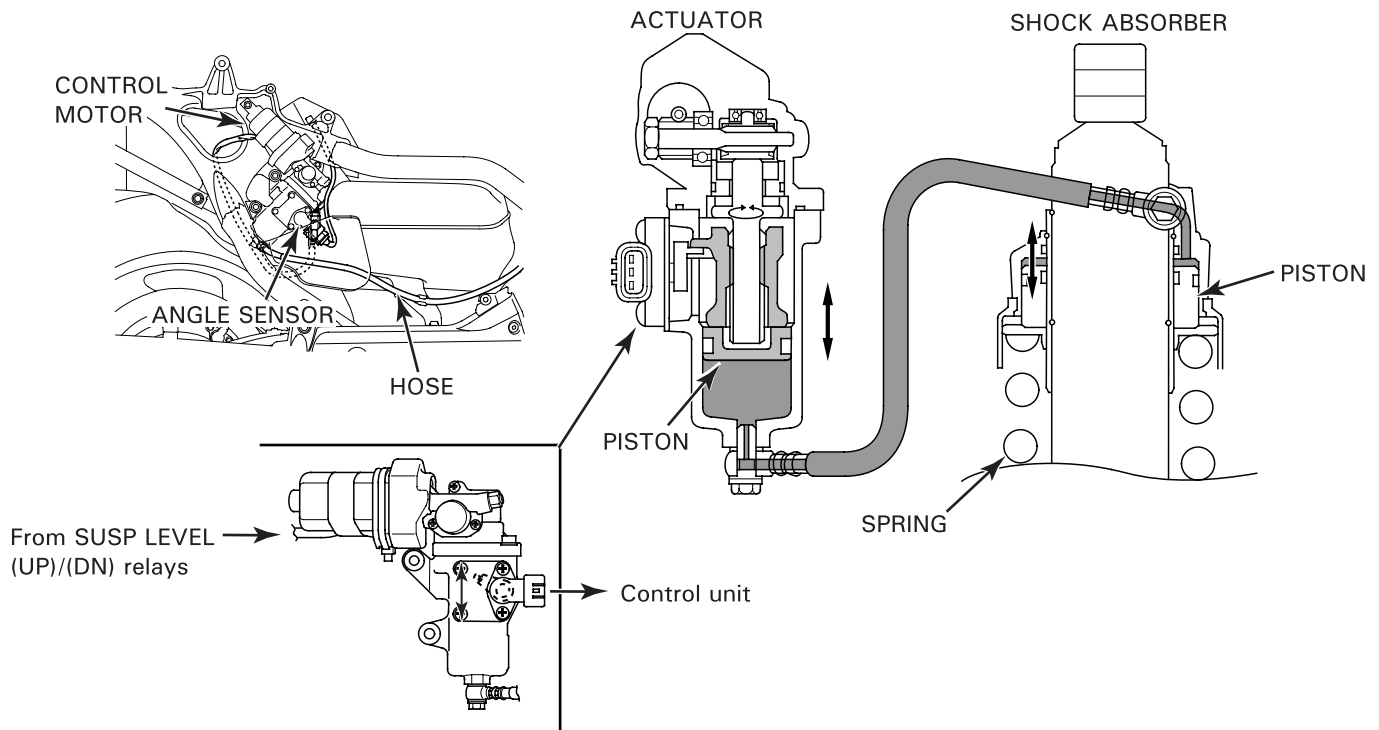

# ANTI-LOCK BRAKE SYSTEM (ABS)

## SUMMARY

The ABS is designed to help prevent wheel lock-up during hard braking or braking on loose or slippery surfaces. ABS momentarily reduces the brake caliper fluid pressure when the wheel is about to lock. When the system senses that the tendency for wheel lock is reduced, brake caliper fluid pressure is restored. ABS repeats this cycle as required for secure brake performance with minimum possibility of wheel lock.

In this ABS, brake fluid pressure is directly controlled by the motor's regulation of the rotational angle of the piston-crank mechanism, which in turn controls the brake fluid. Therefore, in comparison with other ABSs, the modulator size, number of parts, and weight are all substantially reduced. In addition, the fluid pressure can be regulated continuously, unlike ABSs which have staged control. This ABS has a higher accuracy of control in a more simplified system.

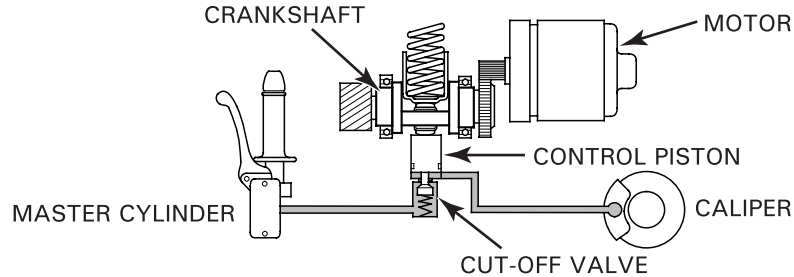

## COMPONENT LOCATIONS

- (1) ABS indicator:  
Blinks or stays on when a problem occurs in the ABS.
- (2) Pulser rings (front/rear):  
Rotates with the wheel and detects wheel speed using the wheel speed sensor.
- (3) Wheel speed sensors (front/rear):  
Inputs the pulse signal, generated proportionally to the rotating speed of the pulser ring in the ABS control unit.
- (4) Modulators (front/rear):  
Adjusts the caliper fluid pressure.
- (5) ABS control unit (ECU):  
Controls the ABS by monitoring the input signals of each sensor.

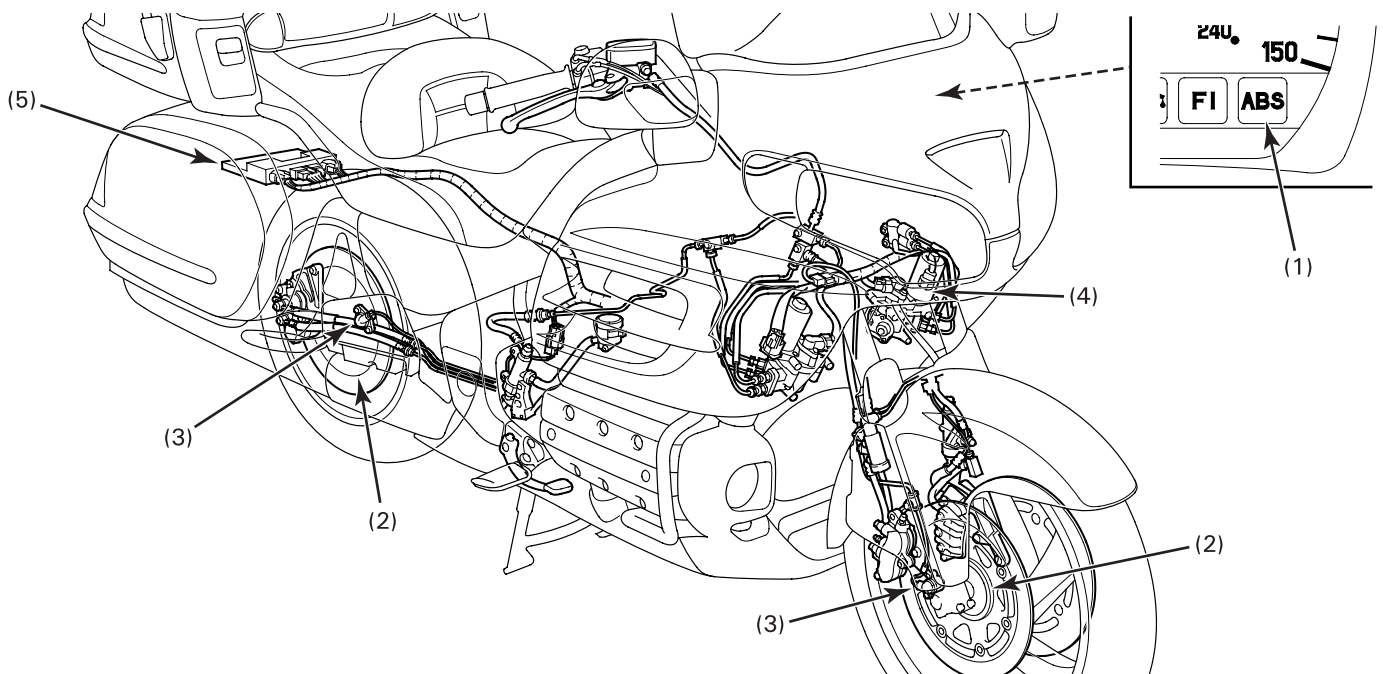



## TECHNICAL FEATURES

### SYSTEM CONSTRUCTION

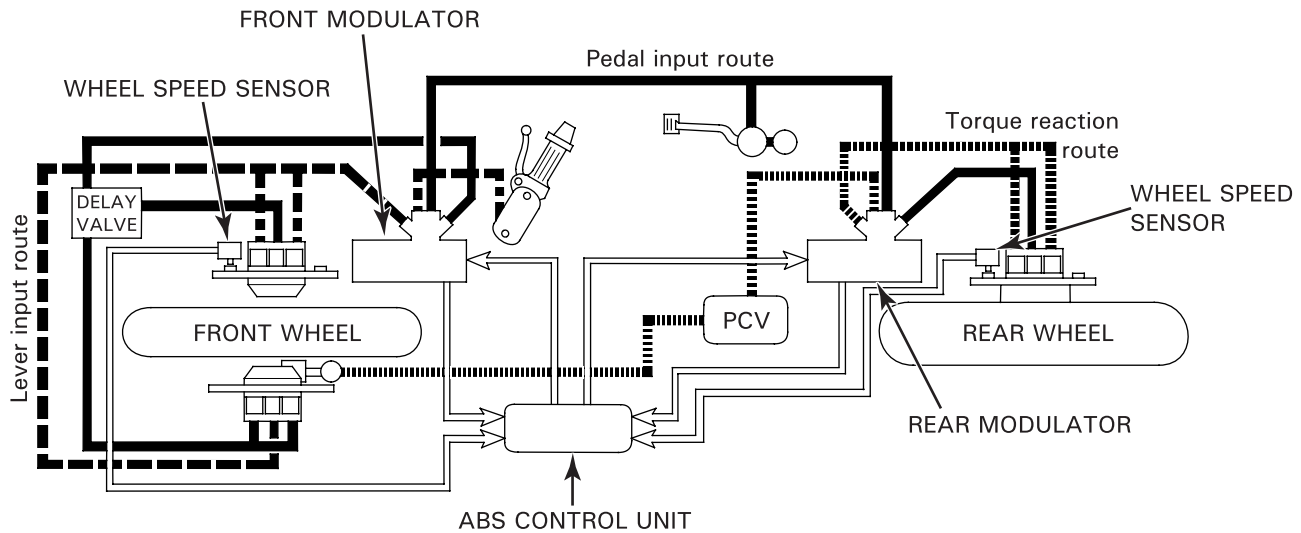

### MOTOR DRIVEN MODULATOR

The modulator controls the brake fluid pressure that is essential for ABS operation. This motorcycle is equipped with separate and independent front and rear modulators. At the same time, in order to combine with the Linked Brake System (LBS), a single modulator controls two routes for brake fluid pressure, as two routes for braking input are given respectively to the front and rear wheels.

The modulator consists of the following parts:

- Control piston: Operates in accordance with the change of the crankshaft angle and adjusts the caliper fluid pressure. Because each modulator must provide simultaneous control over two separate systems, each features two sets of control pistons.
- Crankshaft: Turns with the control motor via the reduction gears to change the piston position.
- Back-up spring: Pushes the control pistons up (holds the cut-off valve open) by way of the crankshaft.
- Control motor: Drives the crankshaft and adjusts the pressure in the system.
- Crank angle sensor: Detects the crankshaft angle.
- Cut-off valve\*: Shuts off the hydraulic pressure to the brake caliper (see page 24-9).

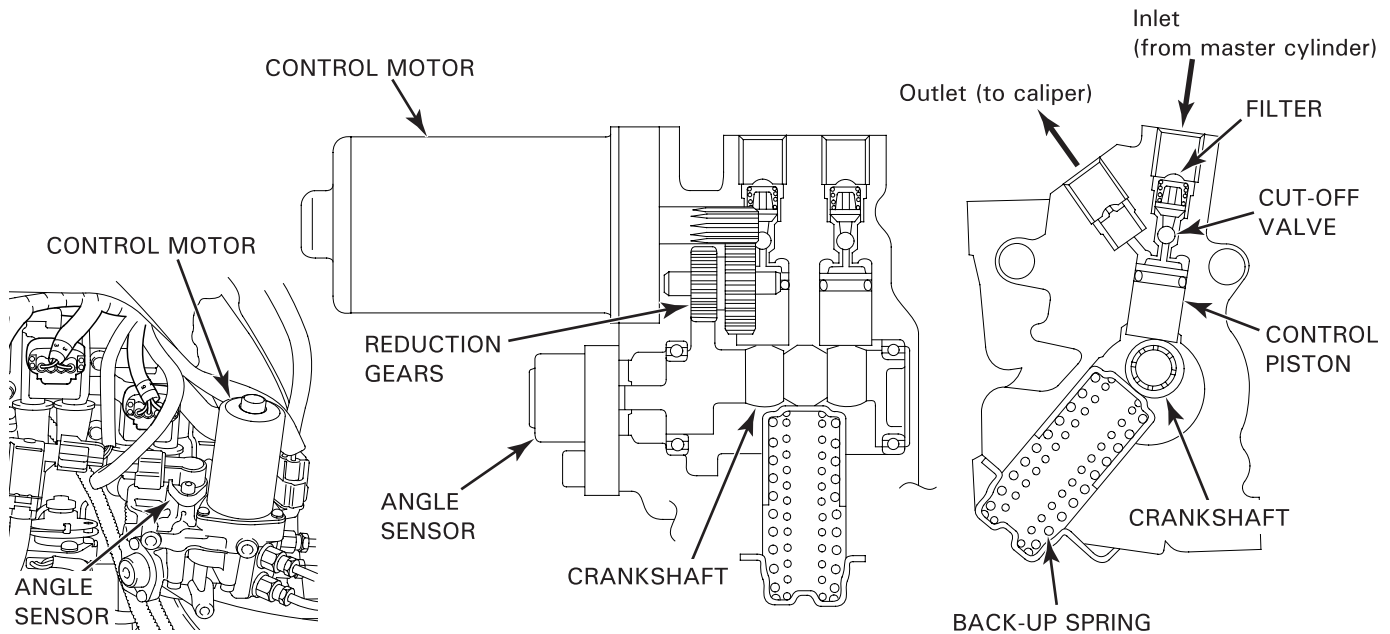

**\*3-STAGE CUT-OFF VALVE**

A 3-stage cut-off valve was created by adding a spring-loaded orifice valve on top of a spring-loaded ball-type cut-off valve. By positioning the orifice valve in-line with the cut-off valve we obtain three stages of operation.

**Stage 1:**

When the ABS is engaged, the control piston moves down to cut off flow to both the cut-off valve and orifice valve, eliminating hydraulic flow between the master cylinder and brake caliper.

**Stage 2:**

The control piston moves up slightly to open the cut-off valve, leaving the orifice valve closed. This stage permits only a small amount of hydraulic pressure to flow through the orifice valve to the brake caliper.

**Stage 3:**

The control piston returns to its normal, uppermost position, opening both the cut-off valve and orifice valve, and restoring full hydraulic pressure for conventional brake operation.

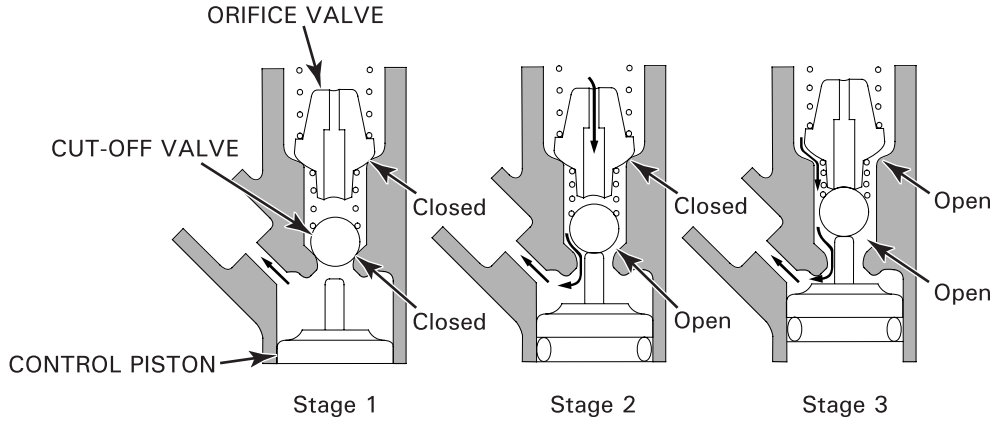

**WHEEL SPEED SENSOR/PULSER RING**

The wheel speed sensor is a contactless sensor that detects front and rear wheel speed. The sensor consists of a permanent magnet and Hall element, and is connected to the ABS control unit. When the projection on the pulser ring (that is rotating with the wheel) passes across the wheel speed sensor, voltage pulses are generated at the sensor. The ABS control unit detects the wheel speed as it receives the pulse signal, because the frequency of the signal increases proportionally to the wheel speed.

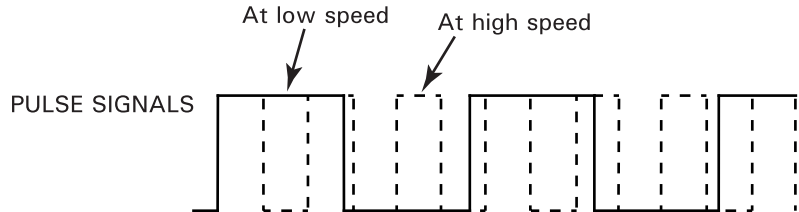
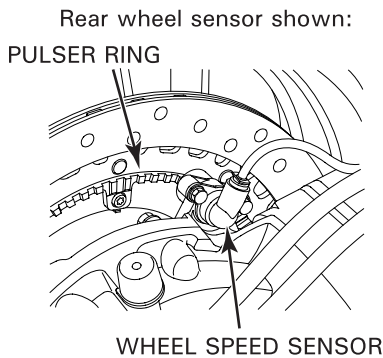

## TECHNICAL FEATURES

### ABS CONTROL UNIT

- **Modulator motor control:**  
The ABS control unit monitors both the two wheel speed sensors and the two modulator crank angle sensors that provide precise readings of each modulator's crankshaft positioning (i.e., control piston position). The ABS control unit directs its motor driven control signals (control unit with the built-in motor driver) to deliver high-amperage electrical output to the control motors and thus operates the system.
- **Self-diagnosis function:**  
The dual-CPU configuration ensures instant recognition of computer-related malfunctions, since the two CPUs run constant checks on each other whenever the ignition switch is turned to "ON."  
When the ignition switch is turned to "ON," the ABS control unit evaluates its internal circuits. The indicator blinks when an abnormality is detected in the system. When the system is normal, the ABS indicator stays on indicating that the ABS control unit is in the stand-by mode for the wheel speed sensor and modulator crank angle sensor signals. The wheel speed sensors send signals to the control unit after the motorcycle starts to move (approximately 10 km/h or above), then the control unit evaluates the system condition by activating the modulator control motors and receiving signals from the crank angle sensors. The ABS indicator goes off when the system is found to be normal. The control unit monitors its main functions while the motorcycle is moving, whether the brakes are engaged or not. When it detects a problem, the ABS indicator blinks.
- **Change-over function:**  
When the ABS control unit detects a problem through its self-diagnosis function, it stops the ABS function. The back-up spring in the modulator pushes the control piston automatically to open the cut-off valve and restore conventional brake operation.
- **Problem code storage function:**  
Problem codes can be memorized and stored in the ABS control unit (up to two codes), and can be retrieved and indicated by the number of times the ABS indicator blinks.

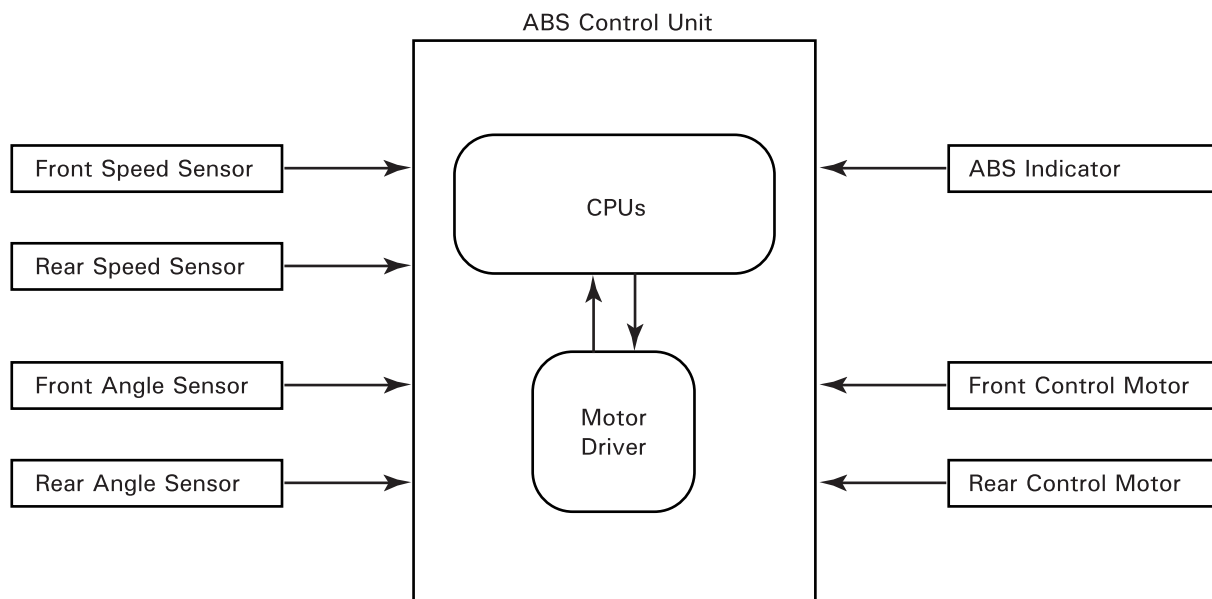
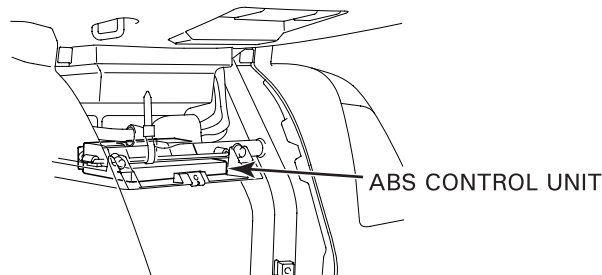

**MODULATOR OPERATION**

- Pressure DECREASE:  
When the ABS control unit detects any tendency towards wheel lock, it rapidly reduces hydraulic pressure to the brake caliper by rotating the crankshaft to lower the control piston, closing the cut-off valve.
- Pressure HOLD:  
Following a predetermined decompression interval, the crankshaft is rotated up slightly to move the control piston into the pressure hold position, which permits the slipping wheel to recover its rotational speed.
- Pressure INCREASE:  
Once the ABS control unit detects full wheel-speed recovery, it rotates the crankshaft back into its highest position. This rapid cycle of pressure DECREASE, HOLD, and INCREASE makes possible nearly instantaneous correction of changes in wheel rotation while ensuring highly accurate control of hydraulic pressure to both independent sets of brake caliper pistons.

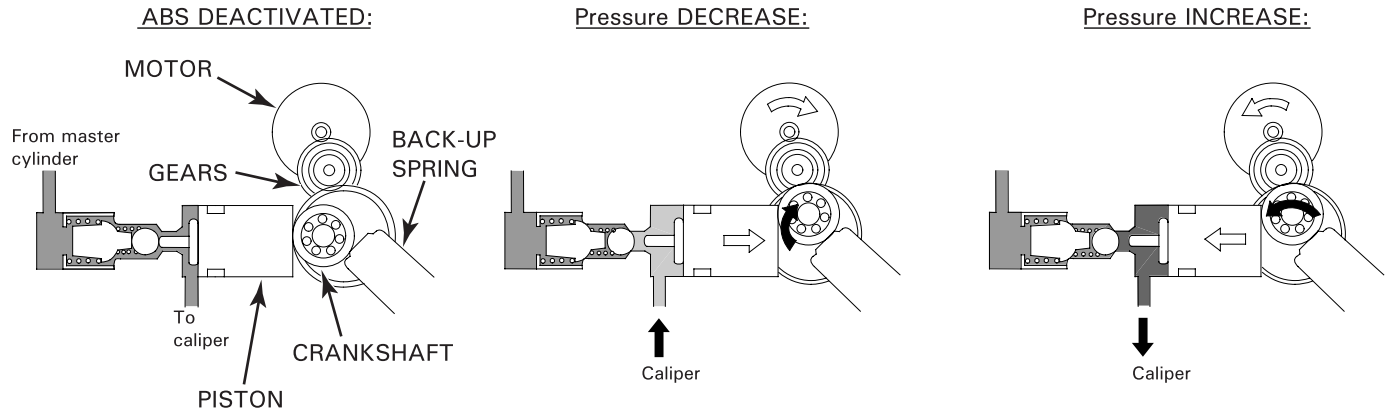

## TECHNICAL FEATURES

### IGNITION COIL WITH BUILT-IN IGNITER

Each ignition coil has a built-in igniter that boosts the ignition signal (5V) from the engine control module (ECM) to generate the primary side voltage.

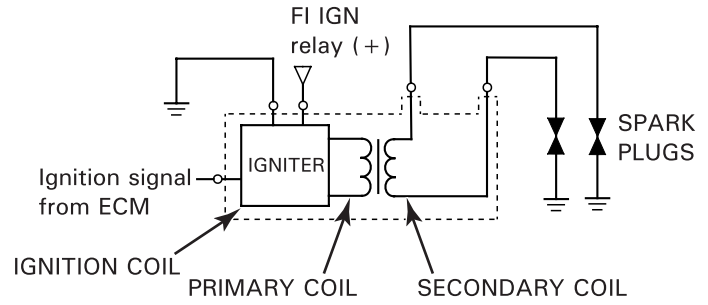
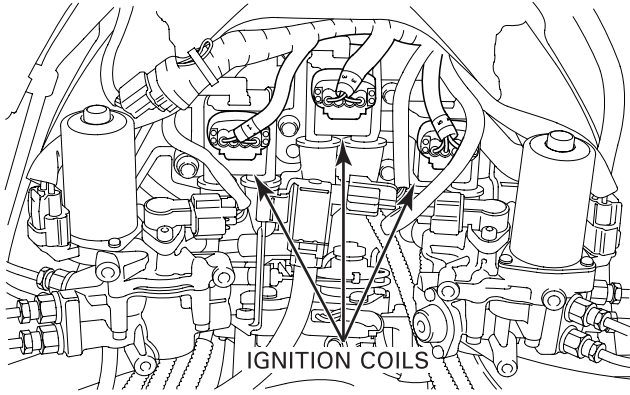

# 25. TROUBLESHOOTING

---

<b>ENGINE DOES NOT START OR IS HARD TO START .....</b>	<b>25-2</b>	<b>POOR PERFORMANCE AT LOW AND IDLE SPEED.....</b>	<b>25-5</b>
<b>ENGINE LACKS POWER .....</b>	<b>25-3</b>	<b>POOR PERFORMANCE AT HIGH SPEED ....</b>	<b>25-6</b>
		<b>POOR HANDLING.....</b>	<b>25-6</b>



# ENGINE DOES NOT START OR IS HARD TO START

### 1. Spark Plug Inspection

Remove and inspect spark plugs.

***Are the spark plugs in good condition?***

- NO** – • Incorrect spark plug heat range  
• Incorrect spark plug gap  
• Dirty air cleaner

**YES** – GO TO STEP 2.

### 2. Spark Test

Perform spark test.

***Is the spark quality good?***

- NO** – • Faulty spark plug  
• Loose or disconnected ignition system wires  
• Faulty ignition coil  
• Broken or shorted spark plug wire  
• Faulty ignition pulse generator  
• Faulty engine stop switch  
• Faulty PGM-FI IGNITION relay  
• Faulty engine control module (ECM)

**YES** – GO TO STEP 3.

### 3. Programmed Fuel Injection System Inspection

Check the fuel injection system.

***Is the fuel injection system normal?***

- NO** – Faulty fuel injection system (section 5)

**YES** – GO TO STEP 4.

### 4. Cylinder Compression Inspection

Test the cylinder compression.

***Is the compression as specified?***

- NO** – • Valve stuck open  
• Worn cylinder and piston rings  
• Damaged cylinder head gasket  
• Seized valve  
• Improper valve timing

**YES** – GO TO STEP 5.

### 5. Engine Start Condition

Start by following the normal procedure.

***Does the engine start but stop?***

- YES** – • Leaking intake manifold gasket  
• Faulty idle air control valve  
• Improper ignition timing (Faulty ECM or ignition pulse generator)  
• Contaminated fuel

---

## ENGINE LACKS POWER

### 1. Drive Train Inspection

Raise wheel off the ground and spin by hand.

***Does the wheel spin freely?***

- NO** – • Brake dragging  
• Worn or damaged final gear bearings

**YES** – GO TO STEP 2.

### 2. Tire Pressure Inspection

Check the tire pressure.

***Are the tire pressures correct?***

- NO** – • Faulty tire valve  
• Punctured tire

**YES** – GO TO STEP 3.

### 3. Clutch Inspection

Accelerate rapidly low to second.

***Does the engine speed change accordingly when clutch is released?***

- NO** – • Clutch slipping  
• Worn clutch discs/plates  
• Warped clutch discs/plates  
• Weak clutch spring  
• Faulty hydraulic assist system  
• Additive in engine oil

**YES** – GO TO STEP 4.

### 4. Engine Performance Inspection

Accelerate lightly.

***Does the engine speed increase?***

- NO** – • Clogged air cleaner  
• Restricted fuel flow  
• Clogged muffler

**YES** – GO TO STEP 5.

### 5. Spark Plug Inspection

Remove and inspect spark plugs.

***Are the spark plugs in good condition?***

- NO** – • Plugs not serviced frequently enough  
• Incorrect spark plug heat range

**YES** – GO TO STEP 6.

### 6. Engine Oil Inspection

Check the oil level and condition.

***Is the engine oil in good condition?***

- NO** – • Oil level too high  
• Oil level too low  
• Contaminated oil

**YES** – GO TO STEP 7.

### 7. Ignition Timing Inspection

Check the ignition timing.

***Is the ignition timing as specified?***

- NO** – • Faulty engine control module (ECM)  
• Faulty ignition pulse generator

**YES** – GO TO STEP 8.

## TROUBLESHOOTING

---

### 8. Cylinder Compression Inspection

Test the cylinder compression.

***Is the compression as specified?***

- NO** – • Valve clearance too small  
• Worn cylinder and piston rings  
• Damaged cylinder head gasket  
• Improper valve timing

**YES** – GO TO STEP 9.

### 9. Programmed Fuel Injection System Inspection

Check the fuel injection system.

***Is the fuel injection system normal?***

**NO** – Faulty fuel injection system (section 5)

**YES** – GO TO STEP 10.

### 10. Lubrication Inspection

Remove cylinder head cover and inspect lubrication.

***Is the valve train lubricated properly?***

**NO** – Clogged oil passage

**YES** – GO TO STEP 11.

### 11. Overheating Inspection

Check for engine overheating.

***Is the engine overheating?***

- YES** – • Coolant level too low  
• Fan motor not working (Faulty fan motor or ECM)  
• Thermostat stuck closed  
• Excessive carbon build-up in combustion chamber  
• Use of poor quality fuel  
• Clutch slipping  
• Wrong type of fuel

**NO** – GO TO STEP 12.

### 12. Engine Knocking Inspection

Accelerate or run at high speed.

***Is the engine knocking?***

- YES** – • Worn piston and cylinder  
• Wrong type of fuel  
• Excessive carbon build-up in combustion chamber  
• Ignition timing too advanced (Faulty ECM)

**NO** – Engine does not knock

---

## POOR PERFORMANCE AT LOW AND IDLE SPEED

### 1. Intake Manifold Gasket Inspection

Check for leaking intake manifold gasket.

***Is the intake manifold gasket leaking?***

**YES** – • Loose intake manifold mounting bolts  
• Damaged intake manifold gasket

**NO** – GO TO STEP 2.

### 2. Spark Test

Perform spark test.

***Is the spark quality good?***

**NO** – • Faulty spark plug  
• Fouled spark plug  
• Loose ignition system wires  
• Broken or shorted spark plug wire  
• Faulty ignition pulse generator  
• Faulty ignition coil  
• Faulty engine control module (ECM)

**YES** – GO TO STEP 3.

### 3. Ignition Timing Inspection

Check the ignition timing.

***Is the ignition timing as specified?***

**NO** – • Faulty engine control module (ECM)  
• Faulty ignition pulse generator

**YES** – GO TO STEP 4.

### 4. Programmed Fuel Injection System Inspection

Check the fuel injection system.

***Is the fuel injection system normal?***

**NO** – Faulty fuel injection system (section 5)

## TROUBLESHOOTING

---

### POOR PERFORMANCE AT HIGH SPEED

#### 1. Ignition Timing Inspection

Check the ignition timing.

***Is the ignition timing as specified?***

**NO** – • Faulty engine control module (ECM)  
• Faulty ignition pulse generator

**YES** – GO TO STEP 2.

#### 2. Programmed Fuel Injection System Inspection

Check the fuel injection system.

***Is the fuel injection system normal?***

**NO** – Faulty fuel injection system (section 5)

**YES** – GO TO STEP 3.

#### 3. Valve Timing Inspection

Check the valve timing.

***Is the valve timing correct?***

**NO** – Camshafts not installed properly

**YES** – GO TO STEP 4.

#### 4. Valve Spring Inspection

Check the valve springs.

***Is the valve spring free length as specified?***

**NO** – Faulty valve spring

**YES** – Not weak

### POOR HANDLING

#### **Steering is heavy**

- Steering bearing adjustment nut too tight
- Damaged steering head bearings

#### **Either wheel is wobbling**

- Excessive wheel bearing play
- Excessively worn swingarm pivot bearings
- Excessive final gear bearing play
- Bent frame

#### **The motorcycle pulls to one side**

- Front and rear wheels not aligned
- Bent fork
- Bent swingarm
- Bent axle
- Bent frame

ABS MODULATOR.....	16-31	CRUISE CONTROL SYSTEM SPECIFICATIONS.....	1-11
AIR CLEANER.....	3-6	CRUISE/REVERSE CONTROL MODULE	
AIR CLEANER HOUSING.....	5-57	CRUISE CONTROL SYSTEM.....	21-9
ALTERNATOR.....	17-10	STARTER/REVERSE SYSTEM.....	19-39
ANTENNA.....	22-11	CYLINDER COMPRESSION.....	8-6
ANTI-LOCK BRAKE SYSTEM (ABS).....	24-7	CYLINDER HEAD ASSEMBLY.....	8-22
AUDIO SWITCH.....	22-9	CYLINDER HEAD COVER INSTALLATION.....	8-32
AUDIO UNIT.....	22-6	CYLINDER HEAD COVER REMOVAL.....	8-6
BANK ANGLE SENSOR.....	18-13	CYLINDER HEAD DISASSEMBLY.....	8-16
BARO/MAP SENSORS.....	5-67	CYLINDER HEAD INSTALLATION.....	8-24
BATTERY.....	17-6	CYLINDER HEAD REMOVAL.....	8-14
BATTERY/CHARGING SYSTEM		CYLINDER HEAD/VALVES SPECIFICATIONS.....	1-7
SPECIFICATIONS.....	1-10	CYLINDER/PISTON/CRANKSHAFT	
BEFORE STARTING TROUBLESHOOTING.....	16-5	SPECIFICATIONS.....	1-8
BEFORE TROUBLESHOOTING.....	16-8	DELAY VALVE.....	15-38
BODY PANEL LOCATIONS.....	2-3	ECM (ENGINE CONTROL MODULE).....	5-71
BRAKE FLUID.....	3-16	ELECTRIC REAR SUSPENSION SPRING	
BRAKE FLUID REPLACEMENT/AIR BLEEDING.....	15-6	PRELOAD ADJUSTMENT SYSTEM.....	24-6
BRAKE LIGHT SWITCH.....	3-18	EMISSION CONTROL INFORMATION LABELS.....	1-72
BRAKE PAD WEAR.....	3-17	EMISSION CONTROL SYSTEMS.....	1-69
BRAKE PAD/DISC.....	15-13	ENGINE IDLE SPEED.....	5-88
BRAKE SERVO-PRESSURE SENSING		ENGINE INSTALLATION.....	7-11
ANTI-DIVE SYSTEM.....	24-5	ENGINE OIL.....	3-11
BRAKE SWITCH.....	20-37	ENGINE OIL FILTER.....	3-12
BRAKE SYSTEM.....	3-18	ENGINE REMOVAL.....	7-5
BRAKE SYSTEM SPECIFICATIONS.....	1-10	ENGINE SIDE COVER.....	2-5
CABLE & HARNESS ROUTING.....	1-23	EVAPORATIVE EMISSION (EVAP) CONTROL	
CAM CHAIN INSTALLATION.....	8-26	SYSTEM.....	5-74
CAM CHAIN REMOVAL.....	8-12	EVAPORATIVE EMISSION CONTROL SYSTEM.....	3-15
CAMSHAFT POSITION SENSOR.....	5-67	EXHAUST SYSTEM.....	2-18
CAMSHAFT INSTALLATION.....	8-28	FAN CONTROL RELAY.....	20-41
CAMSHAFT REMOVAL.....	8-7	FINAL DRIVE ASSEMBLY.....	12-17
CASE BEARING REPLACEMENT.....	12-14	FINAL DRIVE DISASSEMBLY/INSPECTION.....	12-9
CHARGING SYSTEM INSPECTION.....	17-9	FINAL DRIVE INSTALLATION.....	12-22
CLUTCH.....	9-14	FINAL DRIVE OIL.....	3-15
CLUTCH FLUID.....	3-19	FINAL DRIVE REMOVAL.....	12-7
CLUTCH FLUID REPLACEMENT/AIR BLEEDING.....	9-7	FINAL DRIVE SPECIFICATIONS.....	1-9
CLUTCH MASTER CYLINDER.....	9-8	FORK.....	13-24
CLUTCH SLAVE CYLINDER.....	9-12	FRONT BRAKE CALIPER.....	15-27
CLUTCH SPECIFICATIONS.....	1-7	FRONT FAIRING.....	2-10
CLUTCH SWITCH.....	20-37	FRONT FENDER COVERS.....	2-6
CLUTCH SYSTEM.....	3-19	FRONT LOWER FAIRING.....	2-6
COMBINATION METER.....	20-17	FRONT MASTER CYLINDER.....	15-15
COMPONENT LOCATION		FRONT TURN SIGNAL LIGHT.....	20-13
CLUTCH.....	9-2	FRONT WHEEL.....	13-16
COOLING SYSTEM.....	6-2	FRONT WHEEL/SUSPENSION/STEERING	
CYLINDER HEAD/VALVE.....	8-2	SPECIFICATIONS.....	1-9
CYLINDER/PISTON/CRANKSHAFT.....	11-2	FUEL GAUGE/LOW FUEL INDICATOR.....	20-24
ENGINE REMOVAL/INSTALLATION.....	7-2	FUEL INJECTORS.....	5-61
FINAL DRIVE.....	12-2	FUEL LINE.....	3-5
FRONT WHEEL/SUSPENSION/STEERING.....	13-2	FUEL LINE INSPECTION.....	5-52
FUEL SYSTEM (Programmed Fuel Injection).....	5-2	FUEL PUMP.....	5-54
GEARSHIFT LINKAGE/TRANSMISSION.....	10-2	FUEL PUMP RELAY.....	5-66
REAR WHEEL/SUSPENSION.....	14-2	FUEL SYSTEM (Programmed Fuel Injection)	
COOLANT REPLACEMENT.....	6-6	SPECIFICATIONS.....	1-6
COOLANT TEMPERATURE GAUGE/ECT		FUEL TANK.....	5-63
SENSOR.....	20-22	GEAR POSITION SWITCH.....	20-38
COOLING SYSTEM.....	3-14	GEARSHIFT LINKAGE.....	10-8
COOLING SYSTEM SPECIFICATIONS.....	1-6	GEARSHIFT LINKAGE/TRANSMISSION	
CRANKCASE ASSEMBLY.....	11-22	SPECIFICATIONS.....	1-8
CRANKCASE BREATHER.....	3-7	HANDLEBAR.....	13-7
CRANKCASE COVER BEARING REPLACEMENT.....	10-19	HANDLEBAR SWITCH.....	20-35
CRANKCASE SEPARATION.....	11-6	HAZARD SWITCH.....	20-32
CRANKPIN BEARING.....	11-11	HEADLIGHT.....	20-8
CRANKSHAFT INSTALLATION.....	11-16	HEADLIGHT ADJUSTER.....	20-9
CRANKSHAFT REMOVAL.....	11-13	HEADLIGHT AIM.....	3-19
CRUISE ACTUATOR.....	21-16	HEADSET JUNCTION WIRE.....	22-12
CRUISE CANCEL SWITCH.....	21-14	HORN.....	20-40
CRUISE CONTROL SWITCH.....	21-13	HYDRAULICALLY ASSISTED CLUTCH.....	24-4



# INDEX

IAT SENSOR	5-68
IDLE AIR CONTROL (IAC) VALVE	24-2
IGNITION COIL	18-7
IGNITION COIL WITH BUILT-IN IGNITER	24-12
IGNITION CRUISE RELAY	21-11
IGNITION PULSE GENERATOR	18-9
IGNITION SWITCH	20-34
IGNITION SYSTEM INSPECTION	18-5
IGNITION SYSTEM SPECIFICATIONS	1-11
IGNITION TIMING	18-14
INNER FAIRING	2-10
KNOCK SENSOR	5-69
LICENSE LIGHT	20-15
LIGHTS/METERS/SWITCHES SPECIFICATIONS	1-11
LUBRICATION & SEAL POINTS	1-19
LUBRICATION SYSTEM SPECIFICATIONS	1-6
MAIN JOURNAL BEARING	11-14
MAINTENANCE SCHEDULE	3-4
METER PANEL	2-7
MODEL IDENTIFICATION	1-2
MULTI-DISPLAY CONTROL SWITCH	20-40
NEUTRAL INDICATOR	20-26
NUTS, BOLTS, FASTENERS	3-21
O2 SENSOR	5-69
OIL PRESSURE CHECK	4-5
OIL PRESSURE INDICATOR	20-27
OIL PUMP	4-7
OIL STRAINER/PRESSURE RELIEF VALVE	4-6
OPEN AIR TEMPERATURE SENSOR	20-33
PGM-FI (PROGRAMMED FUEL INJECTION) SYSTEM	5-8
PGM-FI IGNITION RELAY	18-11
PGM-FI SELF-DIAGNOSIS MALFUNCTION INDICATOR FAILURE CODES	5-13
PGM-FI TROUBLESHOOTING	5-16
PISTON/CONNECTING ROD INSTALLATION	11-17
PISTON/CONNECTING ROD REMOVAL	11-7
POSITION LIGHT RELAY	20-31
POWER CONTROL RELAY	19-31
POWER TRUNK LOCK SYSTEM	20-42
PRIMARY GEARS/OUTPUT SHAFT INSTALLATION	10-20
PRIMARY GEARS/OUTPUT SHAFT REMOVAL	10-13
PROPORTIONAL CONTROL VALVE (PCV)	15-39
RADIATOR COOLANT	3-13
RADIATOR/COOLING FAN	6-8
REAR BRAKE CALIPER	15-34
REAR CRANKCASE COVER INSTALLATION	10-24
REAR CRANKCASE COVER REMOVAL	10-11
REAR FENDER A	2-13
REAR FENDER B	2-16
REAR MASTER CYLINDER/BRAKE PEDAL	15-19
REAR WHEEL	14-14
REARVIEW MIRROR	2-7
RELAY BOX	20-16
REVERSE OPERATION	3-20
REVERSE REGULATOR ASSEMBLY	19-28
REVERSE RELAY	19-26
REVERSE RESISTOR ASSEMBLY	19-30
REVERSE SHIFT ACTUATOR	19-36
REVERSE SHIFT MECHANISM	19-42
REVERSE SHIFT RELAY	19-34
REVERSE SWITCH	19-27
SADDLEBAG COMBINATION LIGHT	20-14
SADDLEBAG/TRUNK STAY	2-17
SADDLEBAGS	2-15
SEAT	2-5
SECONDARY AIR SUPPLY SYSTEM	3-14,5-84
SECONDARY MASTER CYLINDER	15-24

SERVICE INFORMATION	
AUDIO SYSTEM	22-3
BATTERY/CHARGING SYSTEM	17-3
BRAKE SYSTEM (ABS)	16-3
BRAKE SYSTEM (Standard)	15-3
CLUTCH	9-4
COOLING SYSTEM	6-3
CRUISE CONTROL SYSTEM	21-3
CYLINDER HEAD/VALVE	8-3
CYLINDER/PISTON/CRANKSHAFT	11-3
ENGINE REMOVAL/INSTALLATION	7-3
FINAL DRIVE	12-3
FRAME/BODY PANELS/EXHAUST SYSTEM	2-2
FRONT WHEEL/SUSPENSION/STEERING	13-3
FUEL SYSTEM (Programmed Fuel Injection)	5-3
GEARSHIFT LINKAGE/TRANSMISSION	10-4
IGNITION SYSTEM	18-3
LIGHTS/METERS/SWITCHES	20-3
LUBRICATION SYSTEM	4-3
MAINTENANCE	3-2
REAR WHEEL/SUSPENSION	14-3
STARTER/REVERSE SYSTEM	19-4
WIRING DIAGRAM	23-3
SERVICE RULES	1-2
SHOCK ABSORBER	14-16
SIDE COVER	2-5
SIDE STAND	3-20
SIDE STAND SWITCH	20-39
SPARK PLUG	3-8
SPEAKER	22-12
SPECIFICATIONS	1-4
SPEED LIMITER RELAY	19-33
SPEEDOMETER	20-20
STARTER RELAY SWITCH A	19-24
STARTER RELAY SWITCH B	19-25
STARTER/REVERSE MOTOR	19-17
STARTER/REVERSE SYSTEM SPECIFICATIONS	1-11
STEERING HEAD BEARINGS	3-22
STEERING STEM	13-41
SUSPENSION	3-21
SUSPENSION LEVEL RELAY	14-29
SUSPENSION LINKAGE	14-18
SWINGARM	14-22
SYSTEM DIAGRAM	
BATTERY/CHARGING SYSTEM	17-2
FUEL SYSTEM (Programmed Fuel Injection)	5-7
IGNITION SYSTEM	18-2
LUBRICATION	4-2
REVERSE SYSTEM	19-3
STARTER SYSTEM	19-2
SYSTEM LOCATION	
AUDIO SYSTEM	22-2
BATTERY/CHARGING SYSTEM	17-2
BRAKE SYSTEM (ABS)	16-2
BRAKE SYSTEM (Standard)	15-2
CRUISE CONTROL SYSTEM	21-2
FUEL SYSTEM (Programmed Fuel Injection)	5-6
IGNITION SYSTEM	18-2
LIGHTS/METERS/SWITCHES	20-2
STARTER/REVERSE SYSTEM	19-2
SYSTEM TESTING	6-5
SYSTEM WIRING CONNECTIONS/LOCATIONS	16-4
TACHOMETER	20-21
THROTTLE BODY	5-58
THROTTLE OPERATION	3-5
TOP SHELTER	2-11
TORQUE VALUES	
ENGINE & FRAME	1-12
STANDARD	1-12

TRANSMISSION ASSEMBLY.....	10-33	STARTER/REVERSE SYSTEM.....	19-6
TRANSMISSION DISASSEMBLY.....	10-26	TRUNK.....	2-13
TRUBLESHOOTING, GENERAL		TRUNK BRAKE/TAILLIGHT .....	20-15
ENGINE DOES NOT START OR IS HARD		TRUNK LOWER COVER.....	2-13
TO START .....	25-2	TURN SIGNAL CANCEL UNIT .....	20-28
ENGINE LACKS POWER .....	25-3	TURN SIGNAL RELAY.....	20-27
POOR HANDLING.....	25-6	VALVE CLEARANCE .....	3-9
POOR PERFORMANCE AT HIGH SPEED .....	25-6	VALVE GUIDE REPLACEMENT.....	8-19
POOR PERFORMANCE AT LOW AND		VALVE SEAT INSPECTION/REFACING .....	8-19
IDLE SPEED.....	25-5	VEHICLE SPEED SENSOR.....	5-81
TRUBLESHOOTING, SPECIFIC.....	16-8	WATER PUMP/THERMOSTAT.....	6-17
AUDIO SYSTEM .....	22-4	WHEEL SPEED SENSOR .....	16-29
BATTERY/CHARGING SYSTEM .....	17-5	WHEELS/TIRES .....	3-22
BRAKE SYSTEM (ABS) .....	16-10	WINDSHIELD.....	2-8
BRAKE SYSTEM (Standard) .....	15-5	WIRING DIAGRAM	
CLUTCH.....	9-6	ABS .....	23-7
COOLING SYSTEM.....	6-4	ACC/TRUNK LOCK CONTROL SYSTEM.....	23-17
CRUISE CONTROL SYSTEM.....	21-4	AUDIO SYSTEM.....	23-22
CYLINDER HEAD/VALVE.....	8-5	COMBINATION METER.....	23-15
CYLINDER/PISTON/CRANKSHAFT.....	11-5	COOLING/CHARGING/IGNITION SYSTEM .....	23-11
FINAL DRIVE .....	12-6	CRUISE CONTROL SYSTEM .....	23-20
FRAME/BODY PANELS/EXHAUST SYSTEM.....	2-2	FUEL SYSTEM (Programmed Fuel Injection) .....	23-9
FRONT WHEEL/SUSPENSION/STEERING.....	13-6	FUSE BOX.....	23-3
FUEL SYSTEM (Programmed Fuel Injection).....	5-5	LIGHTING SYSTEM.....	23-13
GEARSHIFT LINKAGE/TRANSMISSION .....	10-7	STARTER/REVERSE SYSTEM .....	23-12
IGNITION SYSTEM.....	18-4	SUSPENSION LEVEL CONTROL SYSTEM.....	23-5
LIGHTS/METERS/SWITCHES.....	20-4	SUSPENSION LEVEL	
LUBRICATION SYSTEM.....	4-4	CONTROL SYSTEM .....	23-5
REAR WHEEL/SUSPENSION .....	14-5	TURN SIGNAL LIGHTS/HORN .....	23-14